

Planning of Water intake structures for irrigation or hydropower

Planning for intake structures

Helmut Lauterjung / Gangolf Schmidt

A Publication of GTZ-Postharvest Project
in: Deutsche Gesellschaft für Technische
Zusammenarbeit (GTZ) GmbH - 1989

© Deutsche Gesellschaft für Technische Zusammenarbeit
(GTZ) GmbH, Eschborn 1989.

ISBN 3-528-02042-3

Acknowledgements

Deutsches Zentrum für Entwicklungstechnologien- GATE

Deutsches Zentrum für Entwicklungstechnologien - GATE - stands for German Appropriate Technology Exchange. It was founded in 1978 as a special division of the Deutsche Gesellschaft für Technische Zusammenarbeit (GTZ) GmbH. GATE is a centre for the dissemination and promotion of appropriate technologies for developing countries. GATE defines „Appropriate technologies” as those which are suitable and acceptable in the light of economic, social and cultural criteria. They should contribute to socio-economic development whilst ensuring optimal utilization of resources and minimal detriment to the environment. Depending on the case at hand a traditional, intermediate or highly-developed can be the “appropriate” one. GATE focusses its work on the key areas:

- Dissemination of Appropriate Technologies: Collecting, processing and disseminating information on technologies appropriate to the needs of the developing countries: ascertaining the technological requirements of Third World countries: support in the form of personnel, material and equipment to promote the development and adaptation of technologies for developing countries.
- Environmental Protection. The growing importance of ecology and environmental protection require better coordination and harmonization of projects. In order to tackle these tasks more effectively, a coordination center was set up within GATE in 1985.

GATE has entered into cooperation agreements with a number of technology centres in Third World countries.

GATE offers a free information service on appropriate technologies for all public and private development institutions in developing countries, dealing with the development, adaptation, introduction and application of technologies.

Deutsche Gesellschaft für Technische Zusammenarbeit (GTZ) GmbH

The government-owned GTZ operates in the field of Technical Cooperation. 2200 German experts are working together with partners from about 100 countries of Africa, Asia and Latin America in projects covering practically every sector of agriculture, forestry, economic development, social services and institutional and material infrastructure. - The GTZ is commissioned to do this work both by the Government of the Federal Republic of Germany and by other government or semi-government authorities.

The GTZ activities encompass:

- appraisal, technical planning, control and supervision of technical cooperation projects commissioned by the Government of the Federal Republic or by other authorities
- providing an advisory service to other agencies also working on development projects
- the recruitment, selection, briefing, assignment, administration of expert personnel and their welfare and technical backstopping during their period of assignment
- provision of materials and equipment for projects, planning work, selection, purchasing and shipment to the developing countries
- management of all financial obligations to the partner-country.

Deutsches Zentrum für Entwicklungstechnologien - GATE
in: Deutsche Gesellschaft für Technische Zusammenarbeit (GTZ) GmbH
P. O. Box 5180
D-65726 Eschborn
Federal Republic of Germany
Tel.: (06196) 79-0
Telex: 41523-0 gtz d
Fax: (06196) 797352

Content

Preface.....	4
1. Hydrological bases.....	6
2. Planning of the intake structure.....	26
3. Hydraulic operation and calculations.....	39
4. Necessary proofs of stability.....	49
5. Sand trap.....	54
Appendix.....	60
List of symbols.....	98
Bibliography.....	102

Preface

In the age of industrial development, lakes, rivers and canals have been exploited to an ever increasing extent, and dams and weirs for the diversion of river water have been constructed on flowing waterways for various purposes. Likewise, river intakes have been developed ever further for agriculture and the generation of hydroelectric power. Now, when in the industrialized countries, particularly in Europe, this development has practically come to an end - today there is only a very small number of sites for large-scale river water intakes - and in the developing countries the trend towards large-scale projects is, for a variety of reasons, decreasing, small-type projects are to the fore in the field of both energy production and agricultural irrigation.

The exploitation of rivers and streams requires thorough planning, irrespective of whether large-scale or small-scale projects are concerned. The ecological aspects, the compatibility of a project with the environment and the minimization of subsequent damage caused by any measure taken are important planning criteria. For large-scale projects, experienced planning engineers and experts are normally appointed. Micro-projects such as mills, small hydroelectric power plants, and small intake structures for irrigation purposes are often planned and constructed by the users themselves or by experts from other technical fields. Hydrologists and hydraulic engineers are frequently not consulted.

GATE has increasingly received enquiries from all over the world for planning fundamentals for intake structures of small-scale hydroelectric power plants, small irrigation perimeters and potable water intakes. Within the scope of the question-and-answer service, no comprehensive documentation on the planning of intake structures was available. The present work is intended to fill this gap. The authors realize that the relationship between water management and hydraulic engineering which forms the basis of the planning, i.e. the planning criteria, can only be touched on. These are intended to give the non-specialist working on the planning of intake structures some hints on the potential construction and to illustrate the complexity of the interrelationships. In just such small-scale projects as small river dams serious mistakes are often made which result in the destruction of the structures in a very short time during periods of flood. For this reason, an investigation into the discharge behaviour and regime of a flowing waterway from the point of view of water management is of decisive importance. Only in very few cases, however, can these hydrological investigations be carried out by nonspecialists. The methods and the necessary fundamentals are nevertheless given in this planning guide so that the non-specialist can at least see what data must be collected and what information must be made available to the planning engineer.

In addition to the individual types of intake structures, the necessary hydraulic and static calculation methods are given and explained in examples. This enables also the non-specialist to make at least a rough estimate of the dimensions of the structure and to form some idea of the costs involved. It is not the intention of this planning guide to enable non-specialists to plan and construct intake structures. The prerequisites to be met by the intake structure are different for each river and stream, and therefore only the basics can be described here. The operativeness of an installation depends largely upon the planning and, thus, upon the experience of the planning engineer. In just such a sensitive field as the intervention in a river or stream with a view to tapping water for general purposes, a great number of criteria are to be considered, and it is these which are given in this planning guide.

The authors hope that this assistance will contribute to an understanding of the problems involved and in future help to avoid damage to intake structures.

The authors wish to thank the GATE members for their suggestions during the preparation of this planning guide and Professor Dr. H. Wittenberg for looking through the manuscript and giving valuable suggestions on additional information and the representation of the problems.

The authors also wish to thank Mrs. Mewes for the translation, and Mrs. Rubener for the editing.

Helmut Lauterjung
Gangolf Schmidt

1. Hydrological bases

1.1 Presentation of the problem

Intake structures on channels are intended to divert a certain amount of water Q from the channel for various purposes of use (irrigation, potable water supply, hydroelectric power). It must be possible for both the diverted water and the remaining supply to be evacuated without damage being caused.

To perform this task, constructional measures must be taken in and on the channel, and it is necessary to design the intake structures hydraulically and to determine the necessary amount of water to be drawn off. For this purpose, the basic hydrological data must be known or the

- precipitation and
- discharges

determined and evaluated.

In addition to the collection and evaluation of discharge data, possibilities will be presented of how the hydrological component "precipitation" can be used to determine or estimate the resulting runoff of a catchment area. This is necessary whenever measured discharge data are not available in sufficient quantity for the planned site of the intake structure or for the respective catchment area.

The methods and procedures described in this planning guide have been deliberately simplified but they offer a comprehensive representation of the hydrological processes of a catchment area which is sufficiently exact for planning purposes. The methods described here are, however, subject to the following conditions:

- The channel to be considered carries water all the year round.
- The discharge is exclusively formed by - precipitation in the form of rain.
- The catchment areas are smaller than 1,000 m²,
- The discharge behaviour of the river is not influenced by a retention reservoir.

To understand the discharge behaviour of a river, it is necessary to know the water cycle; this is described in Fig. 1.

All the water available in the catchment area such as surface runoff, intermediate runoff, groundwater runoff and air moisture results from precipitation. In each catchment area, however, only a part of the precipitation runs off, the so-called effective precipitation. After a precipitation event, this precipitation runs off in the form of

- surface runoff and
- intermediate runoff.

The residual precipitation, the greatest part of which does not run off, is referred to as loss and is subdivided into the following components:

- interception and trough losses,
- evaporation,
- increase in soil moisture and infiltration.

Besides the direct runoff from precipitation events, in most catchment areas, the runoffs are also supplied from the groundwater during periods with low precipitation. This is why there is a basic runoff which ensures that the rivers described here carry water all the year round.

For a short period of time T immediately after a precipitation event, the following water regime equation is valid:

$$N = A + V + R$$

where N = precipitation above the catchment area during the period of time considered T , A = runoff during T , V = evaporation above the catchment area during T , R = retention in the catchment area during T (= interception, infiltration, etc.).

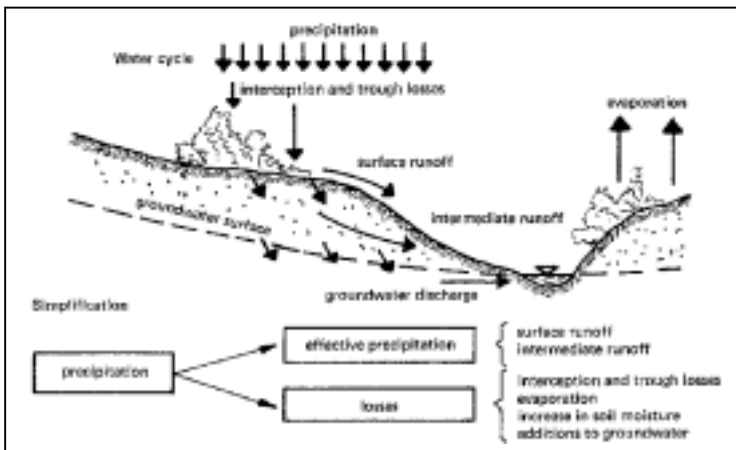

Fig. 1: Simplified representation of the water cycle

When the above-mentioned hydrological quantities are related to the precipitation area A_{E0} , the following components which are important in applied hydrology are obtained:

$$h_N = N / A_{E0} = \text{height of precipitation above } A_{E0} \text{ during } T \text{ in mm}$$

$$h_A = A / A_{E0} = \text{runoff rate of the } A_{E0} \text{ during } T \text{ in mm}$$

$$h_V = V / A_{E0} = \text{evaporation height in the } A_{E0} \text{ during } T \text{ in mm}$$

$$h_R = R / A_{E0} = \text{retention rate in the } A_{E0} \text{ during } T \text{ in mm}$$

Hence the following water regime equation is valid:

$$h_N = h_A + h_V + h_R \text{ (in mm)}$$

Another important characteristic of the runoff behaviour of a catchment area is the runoff coefficient ψ which gives the ratio of the effective precipitation (= precipitation which might form runoff) to the total precipitation:

$$\psi = h_A / h_N$$

The runoff coefficient of a catchment area varies in the course of a hydrological year, as it does not depend only upon area-specific factors such as

- topography,
- geology,
- vegetation,

but also upon event-specific factors such as

- soil moisture before precipitation event,
- season,
- duration of precipitation,
- height of precipitation,
- development and seal coat.

1.2 Determination of the available water supply

1.2.1 Collection of hydrological data

1.2.1.1 Precipitation

For the measurement of the precipitation above a catchment area, rain gauges and/or rain recorders are used (cf. Fig. 2).

The rain gauge can measure only the total precipitation falling within a period of reading. Rain gauges are therefore also referred to as totalizers. The data can be evaluated only as the precipitation sum for certain periods of time (day, month, year). It is not possible to measure an individual event as the observation staff does not carry out the reading after each precipitation event but at a certain time (ea. each morning at 8 a.m.).

On the other hand, the rain recorder records precipitation events on a recording roll or other recording media, depending upon the make. The most usual instruments work on the float or tipping bucket principle (cf. Fig. 2). If maintenance is carried out regularly and the recorder is in good working order, each individual precipitation event can be evaluated. From the records of the recording roll, the duration of precipitation T_N in h, the height of precipitation h_N in mm and the intensity of precipitation i_N in mm/in can be read or determined (cf. Fig. 2).

The quality of the data from precipitation records is dependent upon the maintenance of the instruments, the ability of the observation staff to read the data correctly, and, above all, upon the place of installation. If possible, the rain gauge should be installed in a place where it is possible to record precipitations which are more or less representative of a certain part of the catchment area.

Type of region	Catchment surface per station (km ²)
I. flat terrain, temperate to tropical zones	600-900
II. hilly terrain	100-250
III. mountainous terrain with varying distribution of precipitation	25

Table 1: Minimum density of a rain gauge network

The total number of rain gauges installed in a catchment area decisively influences the exact, representative determination of the total precipitation (cf. section 1.2.3). The number of gauges to be installed depends upon the degree of homogeneity of the distribution of precipitation above the catchment area and upon the topography of the latter.

The lowest density of a rain gauge network according to the WMO rules can be seen in Table 1.

The measuring instrument must be so installed in the terrain that buildings, trees, etc., and the wind do not falsify the precipitation measurement.

All the above-mentioned criteria must be taken into consideration during the collection of data and particularly in the evaluation.

The informational content of the precipitation data depends not only upon the quality of the data recording in situ but also upon the length of the observation period. For the statistical evaluation of the precipitation events, observation series over a period of at least 20 years are necessary. If possible, the observation series should not be interrupted.

Detailed information regarding the construction, operation and cost of precipitation measurement stations is given in the literature [2] and Annex 1.

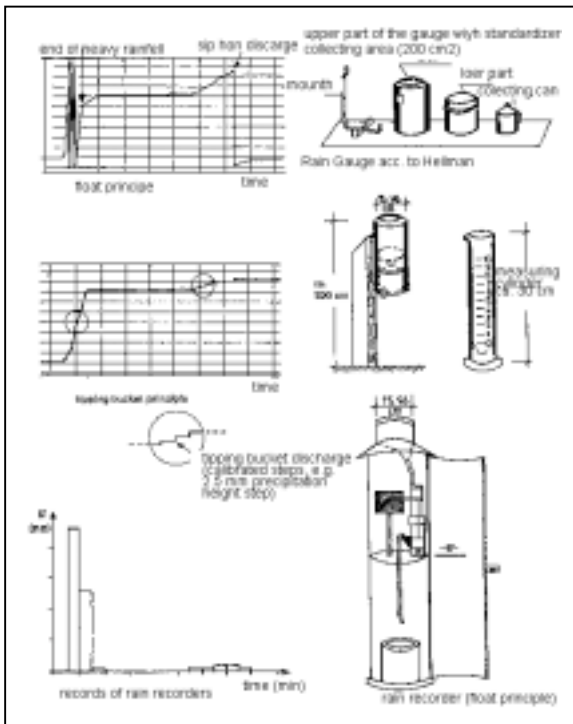

Fig. 2: Precipitation measuring instruments and precipitation recording

1.2.1.2 Discharges and water levels

The measurement of the discharge is in most cases carried out at gauging stations which are installed at the outlets of individual partial catchment areas or at the outlet of a larger catchment area.

A stationary gauging station comprises a gauge to record the water levels and a device for measuring the flow velocity v in m/s. At a cross-section of flow A in m^2 which is known or is to be determined and at the measured mean flow velocity v_m in m/s, this indirect method allows the discharge Q in m^3/s to be determined as follows:

$$Q = A \cdot V_m \text{ (in } m^3/s\text{).}$$

An exact method for determining the flow velocity is the current meter measurement. On the basis of the number of revolutions of a verified current meter, the mean flow velocity v_m is determined by the method explained in section 1.2.2.

A very imprecise but relatively simple and rapid method is the velocity measurement using floats. By this method the mean flow velocity v_m is determined with floats or flotsam and jetsam. It gives a rough knowledge of the discharge conditions, particularly at the cross-sections where an intake structure is planned and discharge measurements have not yet been carried out.

Besides this indirect method, the discharge on small streams can also be directly measured with the aid of a simple wooden weir (cf. section 1.2.2).

During a discharge measurement, the water depth h pertaining to the discharge is also recorded. For this purpose the water-level gauge is used.

Water-level gauges are used in the form of staff gauges and water-level recorders. The staff gauge should be so arranged that the gauge observer can read the staff at any water level. Readings are carried out at certain times (e.g. 8 a.m., 5 p.m., etc.). The observer enters the value in the field book. During a discharge measurement the respective water level should also be read.

A recording gauge continuously registers the water level. The values are usually recorded on a recording roll. Besides a waterlevel recorder, a staff gauge should always be used for checks.

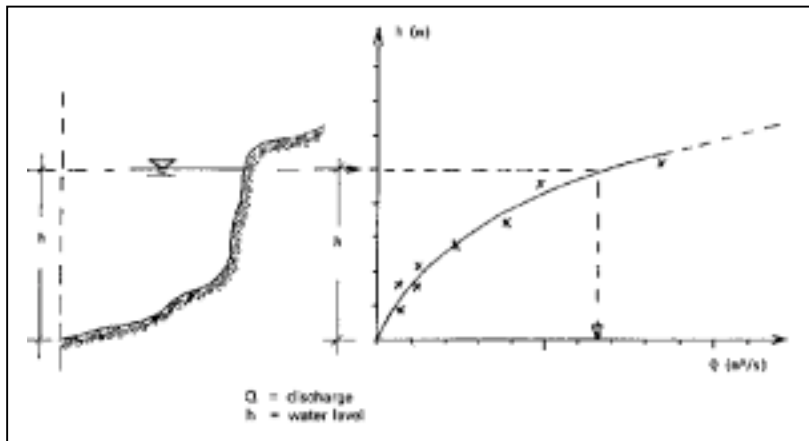

Fig. 3: Water level/discharge radiation (discharge curve) of a channel cross-section

If the discharge measurement is carried out for the range from the lowest discharge to peak discharge, and if for every different discharge value determined the corresponding water level is entered into a system of coordinates, the discharge curve characteristic of a certain discharge cross-section is obtained. With this discharge curve it is possible to read the discharge corresponding to any water level (water depth h) which can be determined relatively rapidly and simply with a water-level gauge (cf. Fig. 3).

This procedure is widely used for economic reasons, as a calibrated discharge curve allows the relatively expensive discharge measurements to be dispensed with. Only one record with a water-level gauge is necessary at the measuring station. This method can, however, be applied only at cross-sections of flow which are not subject to strong seasonal changes of the river bottom and the banks by denudation or alluvial deposits, i.e. the cross-section of flow must be stable.

If, however, the cross-section of flow is unstable, i.e. if the river bottom or the banks are changed by erosion or alluvial deposits during the periods of lowest and peak discharges and if a more suitable site for a discharge measuring station cannot be found, the discharge must be measured continuously and the discharge curve permanently checked by measurements and, if necessary, corrected.

The quality of the discharge measurements and, thus, of the discharge data chiefly depends upon the execution of the discharge measurement. An accurate discharge measurement is possible only with experienced staff who are aware of the numerous interrelations and their influence upon the measurement. This is why the kind of data collection and its execution should, if possible, be taken into account when the data are analysed.

1.2.2 Performance of simple discharge measurements

1.2.2.1 Indirect measurement

In indirect measurement, the discharge at a known cross-sectional area A is determined via the mean Dow velocity v_m as follows:

$$Q = A \cdot V_m \text{ (in m}^3\text{/s).}$$

- Current meter measurement

As the velocity is irregularly distributed in the cross-section of the river, it must be measured in several vertical lines for measurement at different water depths. The velocity at a point of measurement is obtained from the number of revolutions of the current meter during the time of measurement which must not be less than 20 seconds.

The equation calibrated for each current meter

$$v = n \cdot a + b \text{ (in m/s)}$$

where v = determined flow velocity, n = number of revolutions per unit of time, a , b = calibrated parameters (as given by the instrument manufacturer) allows the present flow velocity at the point of measurement to be determined. When the individual velocity values of the vertical line for measurement are plotted, the velocity profile of this line is obtained (cf. Fig. 4). The velocity area is evaluated by planimetering or by summing up the individual areas:

$$f_{vm} = (h_1 \cdot (v_0 + v_1) / 2) + (h_2 \cdot (v_1 + v_2) / 2) + \dots \text{ etc.}$$

With the simplified and most rapid method, only two points of measurements are selected on the vertical line for measurement at 2055 and 8056 of the water depth. The mean velocity results from the arithmetic mean of the two measurement values. The value of the velocity area is obtained by multiplication of the mean velocity by the total water depth h on this vertical line.

When the values of the individual velocity areas are plotted above the corresponding vertical line, the total discharge Q in $\text{m}^3\text{/s}$ is obtained by planimetering or summing up these individual partial areas as follows (cf. Fig. 4):

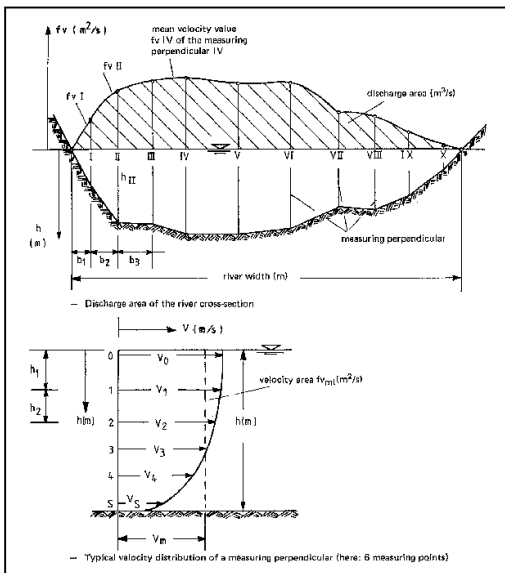

Fig. 4: Determination of the mean flow velocity in a river cross-section

$$Q = ((f_{v0} + f_{v1}) \cdot b_1 / 2) + ((f_{v1} + f_{v2}) \cdot b_2 / 2 + \dots$$

To perform these current meter measurements, the current meter can either be fixed to a rod or suspended with a weight and a float from a wire rope (Fig. 5). In the latter case, a relatively expensive cable crane installation is necessary. The advantage of the velocity measurement with the current meter lies in the simultaneous determination of the wetted area, as the water depth at a vertical line for measurement can be directly measured at the same time with the rod or the cable crane installation.

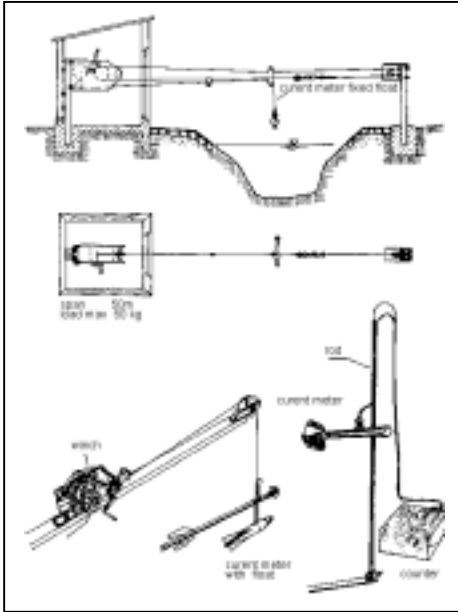

Fig. 5: Discharge measuring instruments for current meter measurement

The criteria for the use of a current meter are as follows:
 current meter on a rod: max. flow velocity < 2.00 m/s;
 max. water depth < 1.50 m
 current meter on a float with weight: max. flow velocity 5 m/s.

For flow velocities > 5 m/s, the discharge should be determined by the velocity measurement using floats as described below.

- Velocity measurement using floats

For the determination of the discharge with floats, the wetted area must be known or determined. In the case of small rivers, this is possible by measuring the water depth on several vertical lines for measurement with rods. The velocity is approximately determined with floats (bottles, wood, cork). If possible, the measurement section should be so long that the floats drift for about twenty seconds. Moreover, it should be straight without obstacles such as trees, ashlars, small islands or rapids, so that a more or less uniform velocity is ensured.

The individual velocity values measured

$$v_i = s / t \text{ (in m/s)}$$

with s = length of measurement section in m, t = drifting time of the float

are higher at the surface than the mean velocity values and must therefore be reduced with a correction factor of 0.8 to

$$v_i^* = 0.8 \cdot v_i \text{ (in m/s).}$$

From the mean value of all measured partial velocities of each float used, the mean velocity v_m is determined with which the instantaneous discharge

$$Q = A \cdot v_m \text{ (in m}^3\text{/s)}$$

can be calculated.

1.2.2.2 Direct measurement

On small and medium-scale rivers, structures in the form of measuring weirs with rectangular overfall which are artificially arranged in the channel cross-section are suitable for discharge measurement (cf. Fig. 6). The rate of discharge is determined with the aid of the weir head h to be read. For the rectangular cross-section the calculation is made using the following formula:

rectangular weir:

$$Q = b(1.782 + 0.24 \cdot \frac{h_e}{w})h_e^{3/2} \text{ (in m}^3\text{/s)}$$

where b = width of weir in m, w = height of weir body in m, $h_e = h + 0.0011$ m (= substitute weir head according to Rehbock [14]).

The discharge measurement must be carried out under the following conditions:

- $b \geq 3h$
- $w \geq 0.3\text{m}$
- $0.1 < h < 0.8\text{m}$
- $Q_{\min} = 40 \text{ l/s}$
- $1 = 4h$.

Furthermore, the wooden weir must be tight. All edges of the weir must be sharp; this is achieved by an arris sloping towards the downstream side (cf. Detail A in Fig. 6). It is best to use a metal rail for this purpose.

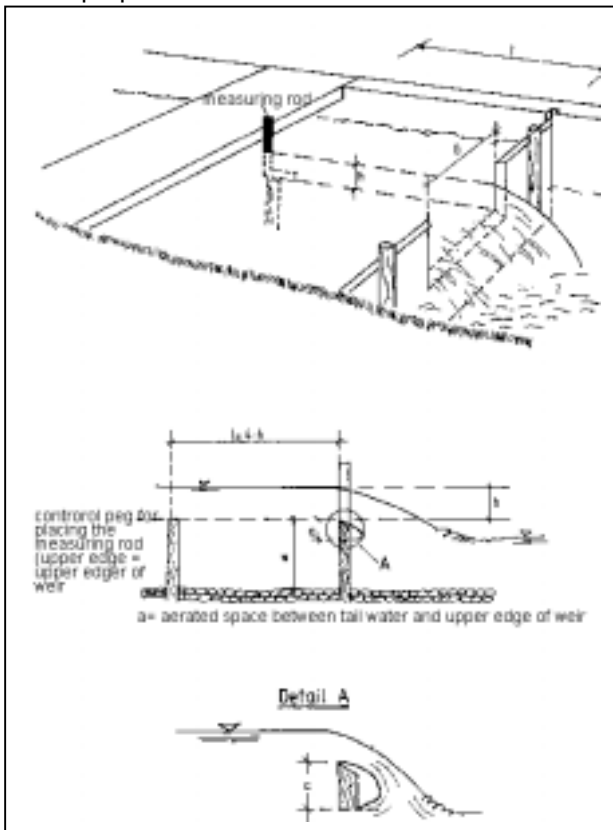

Fig. 6: Discharge measurement with a rectangular weir

(1) Earth canals	ks	
	Solid material, smooth	60
	Sand with some clay or broken rock	50
	Bottom of sand and gravel, with paved slopes	45-50
	Fine gravel, about 10/20/30 mm	45
	Medium gravel, about 20/40/60 mm	40
	Coarse gravel, about 50/100/150 mm	35
	Cloddy loam	30
	Lined with coarse stones	25-30
	Sand, loam or gravel, strongly overgrown	20-25
(2) Rock canals		
	Medium coarse rock muck	25-30
	Rock muck from careful blasting	20-25
	Very coarse rock muck, great irregularities	15-20
(3) Masonry canals		
	Brickwork, bricks, also clinker, well pointed	80
	Ashlars	70-80
	Thorough rubble masonry	70
	Normal masonry	60
	Normal (good) rubble masonry, hewn stones	60
	Coarse rubble masonry, stones only coarsely hewn	50
	Rubble walls, paved slopes with bottom of sand and gravel	45-50
(4) Concrete canals		
	Smooth cement finish	100
	Concrete when steel formwork is used	90-100
	Fair-faced plaster	90-95
	Smoothed concrete	90
	Good formwork, smooth undamaged cement plaster, smooth concrete with high cement content	80-90
	Concrete when wood formwork is used, unplastered	65-70
	Tamped concrete with smooth surface	60-65
	Concrete shells with 150-200kg cement/m ² , according to age and design	50-60
	Coarse concrete lining	55
	Irregular concrete surfaces	50
(5) Wooden channels		
	New, smooth channels	95
	Planed, well-joined boards	90
	Unplaned boards	80
	Older wooden channels	65-70
(6) Plate channels		
	Smooth pipes with flush rivets	90-95
	New cast-iron pipes	90
	Riveted pipes, rivets not flush, several times overlapped on the circumference	65-70
(7) Other linings		
	Rolled mastic asphalt lining of the works canals	70-75

(8) Natural water courses		
	Natural river bed with solid bottom, without irregularities	40-42
	Natural river bed with moderate bed load	33-38
	Natural river bed, weedy	30-35
	Natural river bed with rubble and irregularities	30
	Natural river bed, rich in coarse bed load	28-30
	Foreland, according to vegetation	20-25
	Torrent with coarse rubble (head-sized stones), bed load at rest	25-28
	Torrent with coarse rubble, bed load in motion	19-22

Table 2: Strickler coefficients k_S in the Manning-Strickler formula

1.2.2.3 Discharge calculation

Besides the determination of the discharge with the aid of measuring instruments, it is also possible to calculate the discharge theoretically using the Manning formula for open channels:

$$v = k_S I^{1/2} r_{hy}^{2/3} \text{ (in m/s)}$$

where

k_S = coefficient of roughness in $m^{1/3}/s$,

I = bottomslope,

r_{hy} = hydraulic radius in $m = F / 1_u = \text{wetted area/wetted perimeter} = \text{in } m^2/m$

r_{hy} and I must be determined in the terrain, whereas the coefficient of roughness can be taken from tables (cf. Table 2). When the velocity is known, the discharge can be calculated:

$$Q = A V_m \text{ (in } m^3 / s).$$

1.2.2.4 Estimate of rates of discharge

When discharge measuring stations which have been used for many years are not situated in places which are of interest in the construction of an intake structure or when no discharge values at all are available, the rates of discharge can be estimated or transferred.

If discharge data are lacking, a simple estimate is possible with the aid of the discharge coefficient y . When the discharge coefficient is multiplied by the amount of precipitation N , the estimated rate of discharge V_Q is obtained:

$$V_Q = y N \text{ (in } m^3).$$

According to the precipitation sum value, this estimate can relate to daily, monthly or annual rates of discharge. Attention should be paid to the event and area-specific dependence of the discharge coefficient (cf. also section 1.1).

If discharge data are available for neighbouring stations of the catchment area (cf. Fig. 7), the discharges Q_X at the place x can be transferred from the known discharges. For catchment areas which do not vary too much in nature and size, the discharge can be determined according to the proportionality of the catchment area surfaces A_{EO} :

$$Q_X = Q_1 A_X/A_1$$

If a short series of discharge data is available for the place of interest, a correlation with the discharge data of any other measuring station in the neighbourhood can be sought. It is usual to use linear correlations of the monthly and annual mean values. If there is a good correlation between two stations, the measurements over a period of many years can be used for the place of interest. Detailed information is given in [4]. It should be taken into account that the transfer formulas for peak and lowest discharge are usually different.

1.2.3 Simple data evaluation

1.2.3.1 Precipitation

If precipitation data acquired over several years of observation are available for several stations of a catchment area, the periods of observation of each station should be entered in a bar chart so that these data can be evaluated and analysed (cf. Fig. 8).

The orientation frame is extremely helpful when the available precipitation data are compared and analysed with a view to finding certain interrelations between the individual stations.

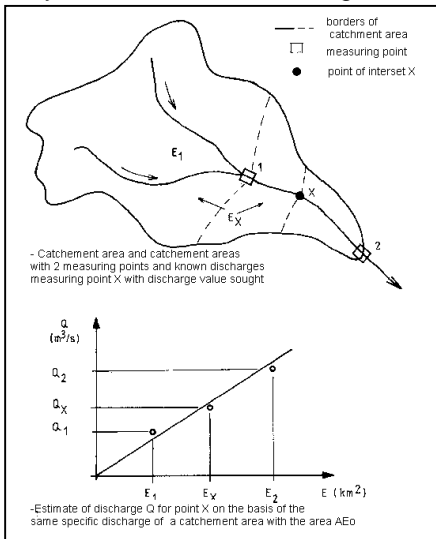

Fig. 7: Estimate of discharge

Furthermore, the precipitation data available can be checked either for irregularities in the data recording or for a change in the precipitation behaviour of a region if the two stations are situated at a great distance from each other. For this purpose, the accumulated data of two neighbouring stations are plotted against each other (cf. Fig. 9).

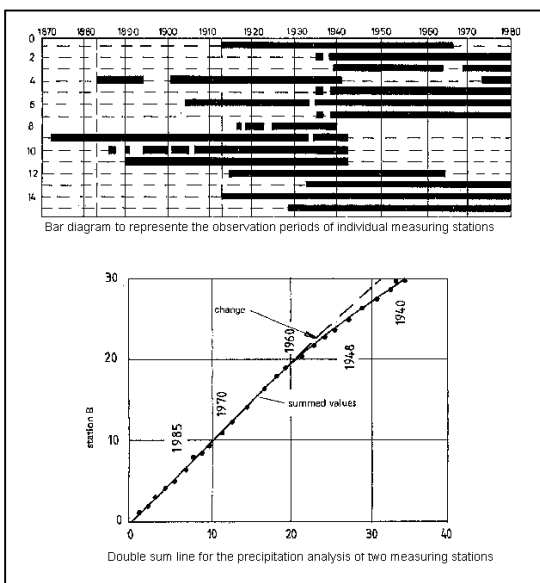

Fig. 8: Possibilities of the precipitation analysis

m	m/n+1	N(mm)	m	m/n+1	N(rnm)
1	0.033	21.4	14	0.536	26.5
2	0.077	22.0	15	0.577	27.6
3	0.115	20.5	16	0.615	29.1
4	0.154	23.3	17	0.654	30.0
5	0.192	23.6	18	0.692	30.0
6	0.231	23.8	19	0.731	30.1
7	0.269	24.1	20	0.769	32.0
8	0.303	24.3	21	0.807	33.8
9	0.345	24A	22	0.845	35.9
10	0.305	24.6	23	0.885	33.2
11	0.423	24.7	24	0.923	40.0
12	0.462	24.9	25	0.962	45.3
13	0.500	25.5			

n = number of events, m = event number (1 = smallest event), N = precipitation (in mm), here: maximum annual 1-hour precipitation, period of observation: 25 years.

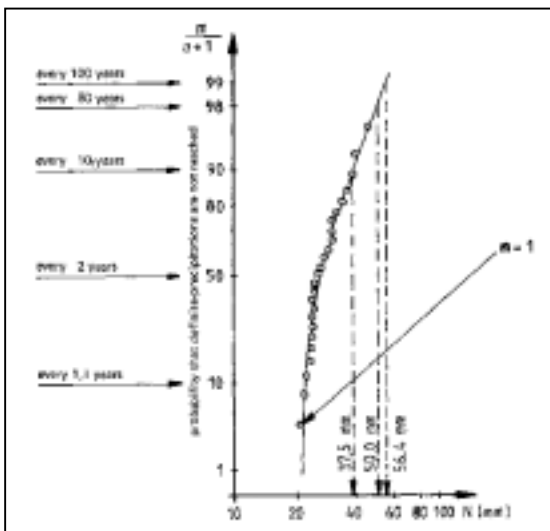

Fig. 9: Determination of the probability that definite precipitations are not reached. Source: [1]

Trends and changes in the slope of the curves or straight lines can be due to a change in the method of data collection or to a change in the precipitation behaviour of the region.

If the precipitation records of a station are in the form of recording strips for a prolonged period of observation (> 10 years), these data can be evaluated for

- the duration of definite precipitation heights,
- the daily, monthly and annual precipitation height, and
- the intensity of precipitation.

However, precipitation data are often available only as the precipitation totals of several precipitation events so that an evaluation is possible only for certain periods (day, month, year).

A simple evaluation of precipitation data is shown in Fig. 9.

The precipitation data of interest are determined from observation series which should be as long as possible, for example:

- specific maximum values of a certain duration (e.g. 15 minutes, 1 hour, 24 hours, etc.),
- maximum daily, weekly and monthly precipitation,
- annual precipitation.

The precipitation data are ordered according to the amount, and an empirical occurrence probability is assigned to each precipitation by the value $m/n + 1$. The n -precipitation events are then plotted on probability paper. If the precipitations are ordered according to the amount in such a way that $m = 1$ is the minimum and $m = n$ the maximum precipitation, the decrease probability is obtained. The

precipitation heights which may occur on an average once in the period sought can be read from the probability curve.

For the determination of the area precipitation (= amount of precipitation falling in a catchment area) the Thiessen polygon method is usually used (cf. Fig. 10).

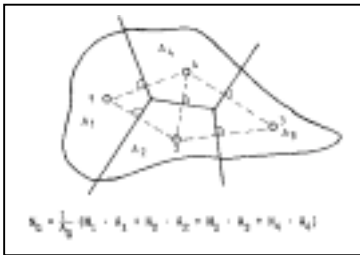

Fig. 10: Thiessen polygon method for the determination of the precipitation area

To establish the Thiessen polygons, neighbouring precipitation stations are connected by straight lines. Subsequently, the mean perpendiculars are erected on all connecting straights. The points of intersection of these mean perpendiculars form the corner points of the Thiessen polygons. Each precipitation station has a polygon.

The individual surface fractions F_i of the individual polygons are subsequently determined.

The area precipitation is then

$$N_G = N_1 \cdot \frac{A_1}{A_{Eo}} + N_2 \cdot \frac{A_2}{A_{Eo}} + \dots$$

where N_G = area precipitation in mm, $N_{1,2} \dots$ = point precipitation of station 1, 2 . . . in mm, $A_{1,2} \dots$ = surface fraction of station 1, 2 . . .

1.2.3.2 Discharges and water levels

For the period of the hydrological year, the discharge data can be graphically represented in the form of discharge hydrographs. For this purpose, the discharge values are plotted against the time (Fig. 11). The time intervals can be of various lengths according to the type of statement (hours, day, month, year).

In most cases the average discharge behaviour of a river is represented by the discharge hydrographs. In this case, the mean monthly discharges MQ of each year or the mean monthly values MMQ from all years observed (as shown in Fig. 11) are plotted.

If the individual discharge values of a hydrograph are ordered according to the amount and the frequency of occurrence, the flow duration curve of the respective discharge values is obtained (Fig. 11). It shows on how many days per unit of time a certain discharge is exceeded or not reached.

This simple statistical evaluation can also be applied to the water-level data given by the gauges or obtained by means of other observations.

These hydrographs or the data from these hydrographs should be evaluated in such a way that the following important discharge data of the respective measuring station are obtained:

- daily, monthly and annual mean of the discharges,
- monthly and annual peak values of the discharges,
- monthly and annual lowest values of the discharges,
- highest and lowest annual means for the measuring periods available.

1.2.3.3 Peak discharges

An evaluation of flood data chiefly serves to forecast flood events which can recur with a certain probability in a defined period of time. A common method for determining such flood events can be seen in Fig. 12 and Table 3.

Parameters of the logarithmic Pearson type III distribution:

arithmetic mean $Z = 2.416$

standard deviation $S_Z = 0.236$

variation coefficient $C_S = 0.99$

$Q_{25} = 549 \text{ m}^3/\text{s}$

$Q_{50} = 588 \text{ m}^3/\text{s}$

$Q_{100} = 620 \text{ m}^3/\text{s}$.

For the determination of the centenary flood HQ_{100} to be sought for intake structures, an uninterrupted period of observation of at least 15 years is necessary.

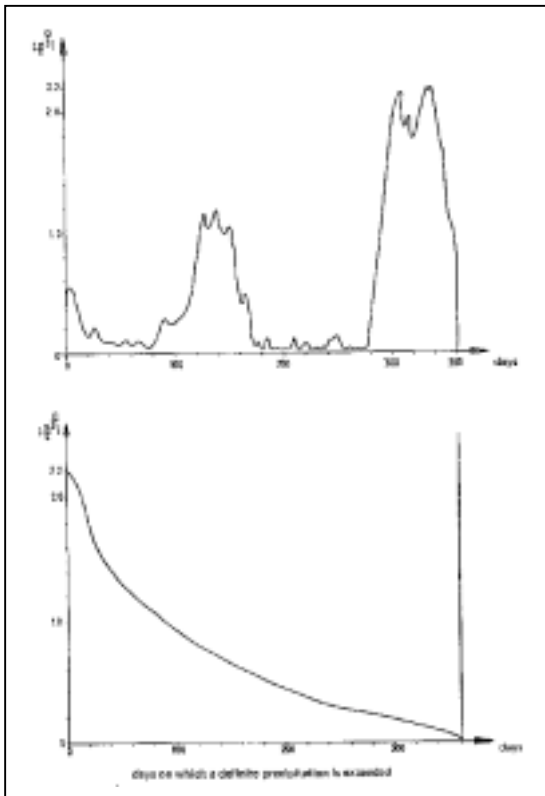

Fig. 11a: Probabilities that definite precipitations are exceeded, determined from the discharge hydrograph evaluation)

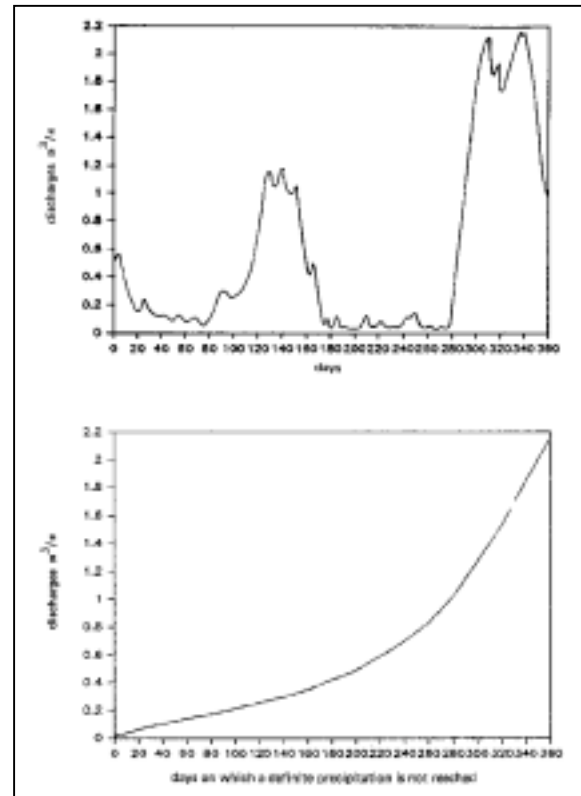

Fig. 11b: Probabilities that definite precipitations are not reached, determined from the discharge (old manual hydrograph (modern computer evaluation)

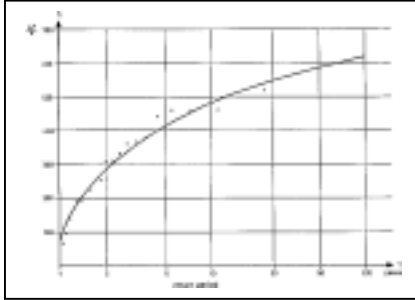

Fig. 12: Graphical determination of the flood probability according to the log-Pearson-3 method

The example shown in Table 3 and Fig. 12 refers to a combined method which is based on a statistical and graphical evaluation. To explain this method, the necessary, relatively comprehensive courses of calculation are given in Annex 2 with another example. Detailed information is contained in the literature [1, 10].

1.2.3.4 Estimate of peak discharges

If no flood data are available for the planned site of the intake structure and if it is not possible to transfer data from other catchment areas, the flood volumes of the peak discharge must be estimated or calculated.

Year	Q (m ³ /s)	m	(T = recurrence interval)
1970	520	1	22
1964	454	2	11
1965	454	3	7.33
1967	454	4	5.5
1960	441	5	4.4
1963	378	6	3.67
1969	376	7	3.14
1955	359	8	2.75
1971	330	9	2.44
1957	307	10	2.2
1959	307	11	2.0
1966	251	12	1.83
1958	248	13	1.69
1961	223	14	1.57
1974	215	15	1.47
1962	194	16	1.38
1956	193	17	1.29
1968	163	18	1.22
1975	140	19	1.16
1972	95	20	1.10
1973	66	21	1.05

Table 3: Flood probability

A rough estimate of certain extraordinary floods can often be obtained by an enquiry among the local population. Statements on water levels, however, must be treated with caution, as depending upon how the questions are phrased and to what extent the population is aware of the project target, the statements of those questioned may contain exaggerations or understatements. Conflicting statements must always be compared.

Furthermore, the highest high-water level can be determined by the flood marks of a flood wave on piers, trees, banks, foreshores, buildings, etc. Conclusions as to the flood volume (peak discharge) can then be drawn with the aid of hydraulic calculations (cf. also section 1.2.2.3).

Another way of estimating the flood peak is the calculation of the peak discharge following a heavy rainfall. This is possible provided that of a heavy precipitation h_N a fraction h_A (evacuation of precipitation as runoff) is evacuated as runoff which is uniformly distributed over the catchment area AEO both geographically and in time.

The time a drop running off takes from the farthest point of the watershed to the waterlevel gauge is referred to as time of concentration and can be determined by the Kirpich formula:

$$T_k = x \cdot \left(\frac{L^2}{\Delta H} \right)^{0.385}$$

where T_K = time of concentration in h, L = running length = watershed - water-level gauge in km, DH = difference in level in m, x = calibration factor.

The discharge peak is determined by selecting a design precipitation of a certain duration T_R and of the height h_N .

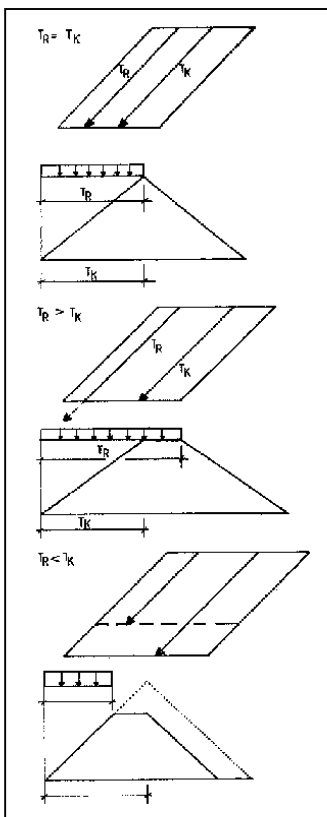

Fig. 13: Influence of the precipitation duration T_R upon the discharge at constant concentration time T_K

The discharge peak sought for the three possible cases is then:

- (a) $T_R = T_K$
- (b) $T_R > T_K$
- (c) $T_R < T_K$

where T_R = duration of precipitation, h_N = height of precipitation, y = discharge coefficient, A_{E0} = surface of catchment area, j = retardation coefficient (in approximation)

$$\varphi = T_R/T_K$$

Here it must be taken into account that the intensity of precipitation in large catchment areas is smaller than in small catchment areas and that the intensity of rainfall decreases with the duration of rainfall. Detailed information is given in the literature [1] and [4].

In addition to these estimates, peak discharges can also be taken from specific peak discharge diagrams which are often available for regions for which comprehensive data exist (cf. Fig. 13).

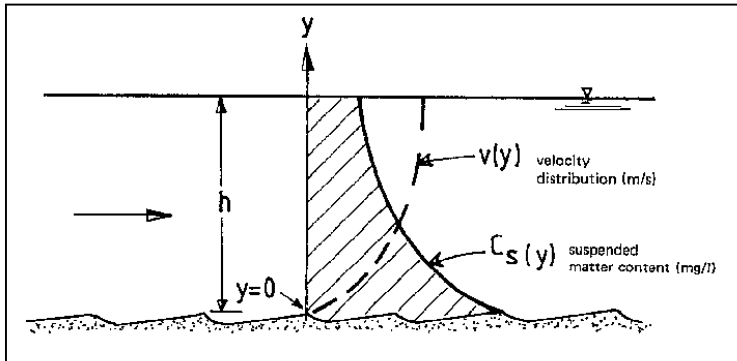

Fig. 14: Idealized distribution of flow velocities v and suspended matter content C_S in the vertical (y -direction) according to DVWK

1.3 Suspended matter and bed load

1.3.1 General

With the discharge each channel entrains solids in the form of suspended matter or bed load.

The suspended matter consists of small solid particles of various size held in suspension by buoyant forces in the water or by turbulence. In the water they are scarcely visible to the naked eye. Peak discharges of an intensive brown, for example, suggest a high solid matter concentration.

The bed load consists of solids such as fine sand, gravel with a small diameter of up to about 3 mm, or coarse material (gravel, stones of various size). The bed load is always transported on the river bottom.

The origin of the solids in the discharge of a channel can be attributed to a great number of causes; for example,

- surface erosion as a result of precipitation, chiefly in catchment areas with sparse vegetation cover,
- erosion in the river bed, in old branches, in reservoirs, and on foreshores, particularly in the case of peak discharges,
- pieces of plants and their decomposition products.

A particle can be transported in the discharge both as bed load and as suspended matter. An exact delimitation is not possible, as the influences in particular the flow velocity - can be very different according to the discharge character.

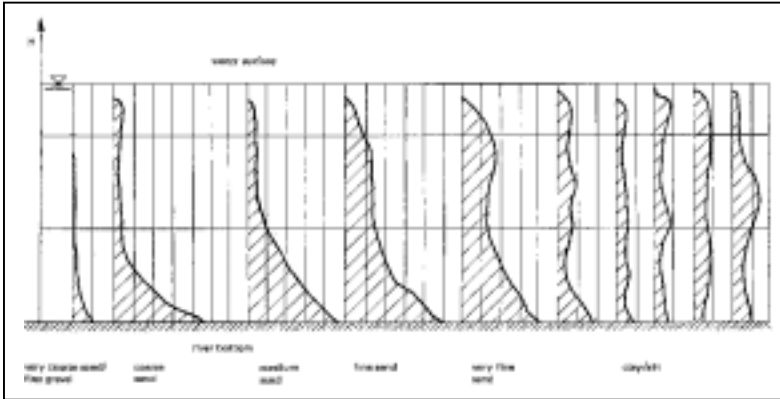

Fig. 15: Distribution of suspended matter concentration of various soil types

The transport of the bed load is subject to the simple rule of thumb that the larger the particle to be transported and the greater its specific weight, the greater the tractive force of the water must be. High flow velocities (e.g. in the case of peak discharges) thus favour bed load transport.

The transport of suspended matter depends upon the settling velocity of the particle and thus upon the particle diameter, the particle form, the specific weight and the flow velocity.

According to Kresser, 1964 [15], the following relationship is valid as a rule of thumb for the determination of the limited particle diameter:

$$d_{\text{limit.}} = \frac{V_m}{360 \cdot g}$$

with $g = 9.81 \text{ m/s}^2$, v_m = mean flow velocity in m/s.

The suspended matter concentration is unevenly distributed in the longitudinal section of the river. This is due to the variable vertical velocity distribution in the river section, which is shown in Fig. 14. Owing to the lower flow velocity, the idealized suspended matter content is higher in the vicinity of the river bottom than at the level of the surface of the water (cf. Fig. 14).

It also very much depends upon the type of particle, which can lead to other distributions of the suspended matter content. This can be seen from Fig. 15.

1.3.2 Stream-morphological influences upon solid matter transport

In the interplay between the tractive force of the water and the resistance of the bottom material, each stream is subject to changes. These are shown in simplified form in Fig. 16 for a longitudinal river section.

1. Erosion section

In the upper course of a river there is often no supply of solid matter from other inflows or solid matter from the surface erosion of the catchment area. Owing to the still low concentration of solid matters, the river is able to take up material, which results in erosion of the river bottom (depth erosion). This is also due to the flow velocities in the upper course which are higher due to the more pronounced slope.

A special case in the classification of this river section is latent erosion. Here, despite the lack of solid matter, the process of erosion has ceased, as the erodable bed material has already been transported downstream by continual scouring and the remaining coarse material forms a sort of protective layer.

2. Equilibrium sections

In the middle and lower course the supply of solid matter is meanwhile so great that the maximum transport capacity has been reached. Slight erosions are compensated by corresponding deposits, i.e. this river section is in equilibrium.

3. Accumulation sections (sedimentation)

In the lower course and the area of the estuary, the supply of solid matter may be so great that the transport capacity of the river is no longer sufficient and the excess solid matter is recognizable in the river bed as deposits (e.g. sand banks).

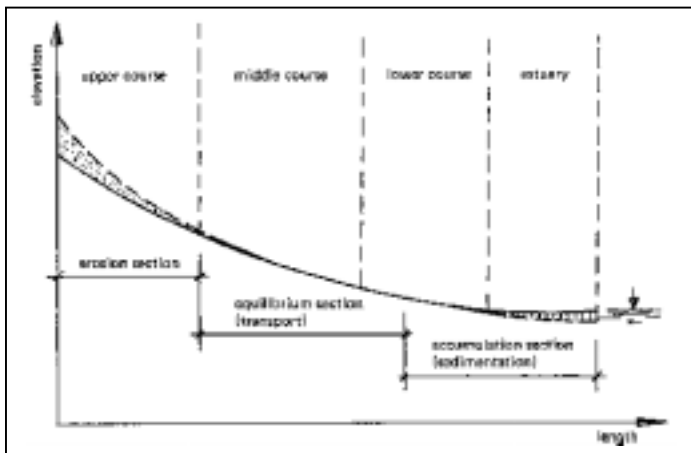

Fig. 16: Sequence of states in a longitudinal section of a river (qualitative)

In every river this theoretical sequence of erosion, equilibrium and accumulation sections can be observed several times in succession, this phenomenon being caused by the slope and local erosion bases. The construction of an intake structure may interfere with this river system.

Before an intake structure is planned, it is therefore necessary to obtain information on the solid matter transport upstream of and in the area of the intake structure so as to be able to estimate the influence of the structure upon the deposit of solid matter in front of it and the erosion behind it, and to determine the type of structure to be used.

Different sections of river can be distinguished by their appearance. This can be done according to the following criteria (source [6]):

1a) river section in a state of erosion:

- a small number of sand and gravel banks rapidly migrating downstream,
- steep banks, possibly steeper than would correspond to the natural angle of slope of the in-situ material,
- washing of the banks and slides in straight river sections,
- subsequent filling becoming necessary in order to secure the fill toes.

1b) river section in a state of latent erosion:

- steep slope (ravine section, gully),
- rocky bottom,
- bottom material coarser than on the banks,
- rock-slide material identifiable beyond any doubt as not belonging to the stream,

- bottom at the same level over a prolonged period in spite of steep slope and high flow velocities,
- no sand banks; gravel banks, if any, always in the same place.

2. river section in a state of equilibrium:

- slope remains constant over a prolonged time,
- bottom remains at the same level over a prolonged period,
- dimensions and form of the river cross-section do not progressively change (but changes over limited periods are possible during flooding),
- type and composition of the particles on the bottom and on the banks do not show fundamental differences,
- no washing of the banks in straight river sections,
- overflows always take place at more or less the same discharges,
- sand banks (if any) are stable and migrate downstream slowly, if at all.

3. river section in a state of accumulation:

- frequent, clearly visible gravel and sand banks often changing in form,
- bottom material finer than the material. On the banks,
- tendency to curve formation, formation of meanders,
- increase in the frequency of overflows and flooding,
- progressive alluvial deposits on the bottom and/or bank.

The influence of intake structures with and without damming upon the river upstream and downstream of the intake is described in detail in [6]. Methods for the quantitative estimate are also given there.

1.3.3 Measurement of amounts of suspended matter and bed load

The measurement of amounts of suspended matter and bed load is aimed at determining the solid matter content of a certain amount of water.

For the suspended matter measurement, indirect measuring methods are suitable which allow the suspended matter content (C_s) to be determined by drawing off a certain amount of water and filtering it, with a subsequent gravimetric determination of the filter residue. Like the discharge measurement, this measurement should, if possible, be carried out in various cross-sectional places of the river. Experience has shown that exact determination of the suspended matter content is possible only with multipoint measurements. The results always relate to the instantaneous discharge existing at the time of measurement, and therefore this discharge must be known. The following definitions are applicable:

- The suspended matter content is the mass of the suspended matter per unit of volume (C_s in mg/l or g/m³).
- By suspended matter transport msf in kg/s the suspended matter is meant which is transported through the cross-section in a certain unit of time.
- The suspended matter load msf is the suspended matter transport totalled for a certain unit of time (hour, day, month, etc.). The unit of time must be indicated.

The determination of the suspended matter content is of great importance. All terms always refer to the river section used for the suspended matter measurement.

For taking samples, numerous suspended matter measuring instruments are available which are placed in the water at the discharge measuring station with a cable crane installation, from a boat or from a bridge. These instruments can take water samples between 1 l and 5 l content. It is important that samples are taken from the various layers of the stream. The most suitable instrument is a wide-necked bottle with a content of 1 l.

A simple but relatively, inaccurate instrument for measuring suspended matter is a 5 l bucket whose content can be exactly read from marks, but this is suitable only for taking samples at the surface. The results thus obtained give only rough indications of the suspended matter content of a stream.

The measurement of the bed load is carried out with a bed load trap which consists of a wire mesh box opened towards the upstream side. As the bed load movement begins only at higher discharges, due to the then increased tractive force of the water, a bed load measurement is necessary only during peak discharges.

For the evaluation of the bed load measurement it is of particular importance to examine the particle composition by means of a screen analysis. Besides this analysis, a description of the bed load with respect to the kind of disposition, the kind of rock and particle size must be given.

As well as taking samples with the bed load trap, it is also possible at times of low discharge to take samples from deposits of sand and gravel banks after the top cover layer has been removed.

For a description of the bed load amounts in a river cross-section, the following definitions apply:

- bed load movement m_G in $\text{kg}/(\text{m} \cdot \text{s})$ mass of bed load transported per unit of width and time;
- bed load transport m_G in kg/s mass of bed load transported through the cross-section in the unit of time;
- bed load m_{Gf}

sum of the mass of bed load transported through the cross-section in a certain unit of time (e.g. month, year).

2. Planning of the intake structure

2.1 Requirements to be met by an intake structure

It is the task of an intake structure to divert from the channel at the tapping point the amounts of water necessary for whatever purpose with or without water being stored. For this purpose an intake structure for evacuating these amounts of water and possibly a structure for damming up the river are necessary. The bottom intake (Tyrolean intake) described in section 2.3.3 which combines intake and damming up in one structure is particularly important in this context.

The individual elements of the intake structure should always be so arranged on the channel that the following basic requirements are met:

1. The arrangement or the construction of a weir and intake structure must be chosen or carried out in such a way that the evacuation of the necessary amounts of diverted water is ensured at any regime of the channel.
2. The peak discharges must be safely evacuated from the weir and from the intake structure without damage being caused. To achieve this, hydrological data must be collected and evaluated in sufficient quantity in order to enable the dimensions to be planned in accordance with safety aspects (cf. sections 1 and 2.4).
3. A simple and moderately priced construction should be aimed at which allows maintenance-free operation and simple repairs to be carried out (cf. section 23).
4. If possible, the diverted water should be free from solid matter in order to prevent the diversion canal from being loaded with large amounts of bed load and/or suspended matter. To achieve this, the site of the intake structures should be selected in accordance with the river training rules explained in section 2.2.

5. It should be possible for the bed load and suspended matter, which is possibly deposited upstream behind the weir, to be evacuated by the water remaining in the river or by intermittent flushing. For this purpose, additional constructional measures should be taken (cf. section 2.2).

From this it is clear that the choice of the tapping point on or in the channel is just as important as the choice of intake structure. The decisions are mutually dependent. A simple construction should be the main objective. Observance of natural physical laws (cf. section 2.2) is an important prerequisite for the correct choice of site for the intake structure on the river bank, since the intake of bed load can be reduced by making use of these laws or by force, i.e. massive structures. Preference should always be given to the first solution.

Whether an intake is chosen with or without a river dam depends not only upon the cost of the weir. The following aspects should also be taken into consideration:

- The topographical conditions upstream of the structure. Damming up results in a backflow in the channel leading to a rise in the water level, which in turn may lead to flooding of the bank areas far upstream of the structure.
- The geotechnical conditions of the bank zones (talus material or rock).
- Height of the bank above the river bottom.
- The ratio of the quantity of diverted water to the residual quantity of water in the river at low discharge, with regard to existing rights of use of the downstream users.
- The channel width in the tapping point (dependence of the water level at times of low discharge in the river; meandering at low discharge in wide rivers, etc.; cost of damming structure, etc.).
- The routing of the diversion canal.
- The intake structure must not narrow the cross-section of flow of the channel; otherwise, at peak discharges, the bottom erosion in the area of the intake structure in the river bed would be increased, which in turn results in a change of the water level. A safe diversion of water at low discharges is therefore no longer ensured.

2.2 Principles for the arrangement of the intake structure on the river

As has already been mentioned, with the discharge, each river entrains solid matter in the form of suspended matter or as bed load (cf. also section 1.3).

The location of an intake structure must be so chosen that the largest possible portion of the bed load remains in the river and is not taken in in the diversion canal with the diverted water. A satisfactory arrangement of the intake structure does not remove the suspended matter; this is the task of a sand trap arranged downstream.

To hold off the bed load the natural hydraulic behaviour of the river can be profited from or technical measures taken:

1. Use of physical laws

In straight sections of river or stream, the water flows approximately in the cross-section of the channel, parallel to the banks. When the bed load transport begins, the bed load is transported accordingly on the bottom of the river.

In bends the direction of the bottom flow changes compared with the surface flow (Fig. 17a). A spiral flow forms which transports the bed load to the inner side of the river. On all streams and rivers it can be observed that gravel and sand banks form at the inside bend, i.e. the bed load is

diverted from the deflecting bank. It could be concluded from this that the most favourable site for the construction of an intake structure is the deflecting bank. Fig. 17b shows for several examples the percentage of the bed load feed into a branch (intake) according to the arrangement of the intake structure or branch in the river section, a quantity of water to be diverted amounting to 50% being taken as a basis. Further results of the investigations are given in [6].

2. Technical measures

As technical measures bed load-deflecting structures in the form of ground sills, flushing canals, etc., in the flow area of the branch are a possibility.

A detailed discussion follows:

The following principles can be derived from the physical relationships:

- (a) If at all possible, intake structures should be arranged on the outside bend.
- (b) If it is necessary to construct the intake structure on a straight river section, a bent flow can be forced in order to be able to profit from natural physical laws.
- (c) According to the rules of river training, special measures for keeping off the bed load are always necessary whenever more than 50% of the water is diverted from the river.
- (d) In addition to the use of natural physical laws, technical measures are always necessary
 - for intake structures where the water is not dammed up (case (c)),
 - for intake structures where the water is dammed up, as the capacity of the silting space in front of the fixed weir is limited and the entrance of bed load into the intake structure cannot be prevented in the long term (cf. also Fig. 18).

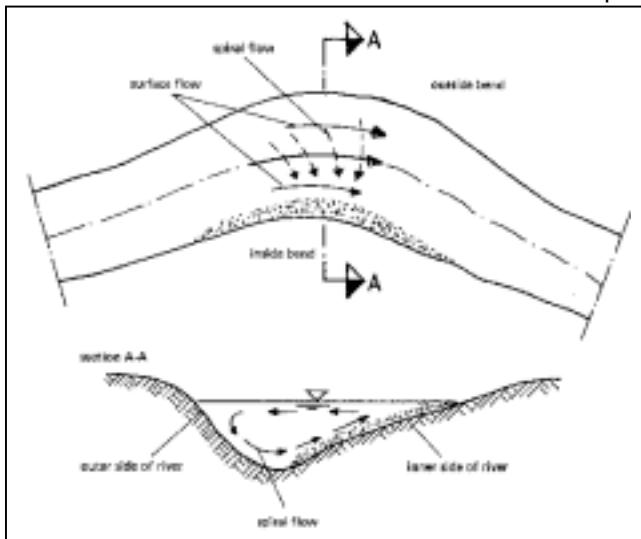

Fig. 17a: Deposits in a river bend

The following guidelines for the construction of intake structures on various river sections are derived from these principles. They also serve to illustrate the examples previously discussed in a summarized form.

Intake structure on a straight river section

If the intake structure is arranged on a straight river section, the deflection of the flow by the power canal results in the bed load being transported to the inside bend, i.e. in the direction of the power canal. In order to prevent this, the flow of the river in front of the intake structure must be deflected so that the bed load remains in the river. For this purpose, groins (cf. Fig. 18) are arranged on the side of the river opposite the intake structure. This forces such a bend of the flow that the intake structure is now situated on the outside bend and the bed load is largely prevented from entering the power canal.

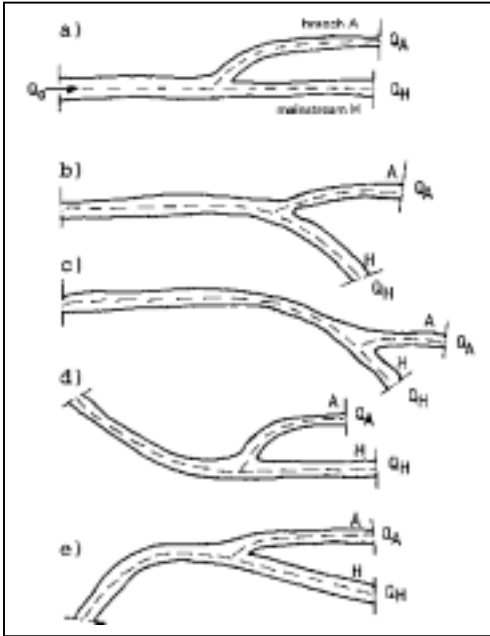

Fig. 17b: Entry of bed load in lateral intakes without additional structures according to [6]

Distribution of bed load in the main stream and branch under the condition of a diversion of 50% $Q_A = Q_H = 0.5 Q_O$		
	remaining of the bed load in the main stream, in %	entry of the bed load in the branch, in %
a	0	100
b	50	50
c	89	11
d	0	100
e	100	0

Intake structure on a bent river section

If intake structures are arranged on bends, the intake must always be situated on the outside bend, as the bed load is transported to the inside and the arrangement of the intake structure outside allows the bed load to be largely diverted from the intake.

The most favourable site for the intake structure is somewhat downstream of the apex of the bend. The spiral flow is strongest here, causing most of the bed load to be transported towards the inner bank.

If the bend in the river section is only slight (Fig. 19), the bending effect can be increased by a groin as described above (cf. Fig. 18). A bend is slight when the angle of the bend $\alpha < 30^\circ$ (Fig. 19).

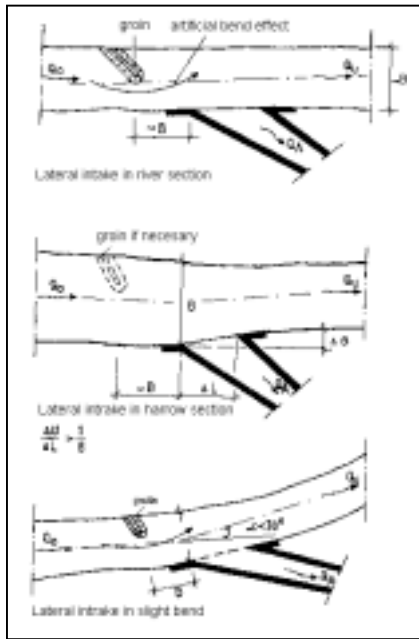

Fig. 18a: lateral intake without damming and repelling of bed load from intake by technical measures

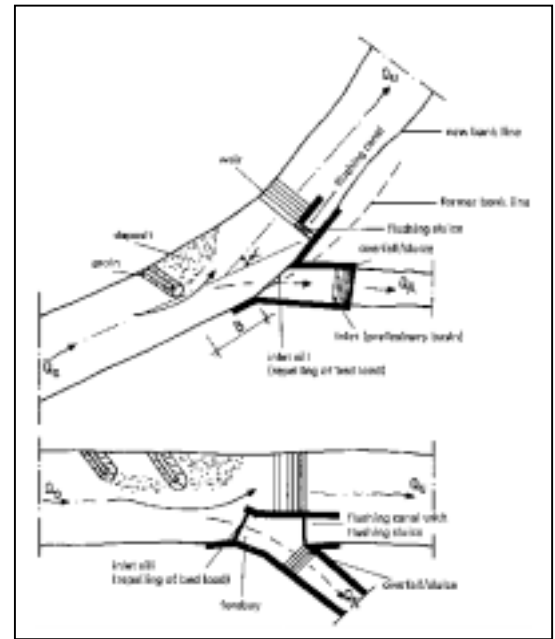

Fig. 18b: Lateral intake with damming and repelling of bed load from intake by technical measures

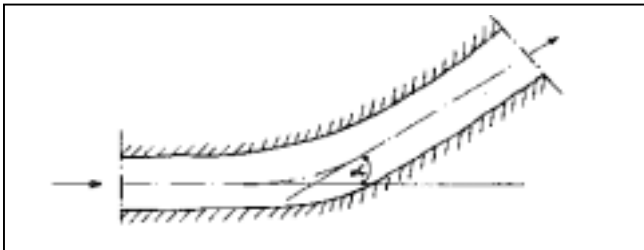

Fig. 19: Angle of bend α
Slight bend at $\alpha < 30^\circ$

2.3 Types of intake structures and their elements

2.3.1 General

Types of intake structures are chiefly distinguished by the method used to divert water from the river:

- lateral intake,
- bottom intake,
- overhead intake (intake of the water via inlets arranged in piers),

as well as encroachments on the river itself, i.e., for example, intake with and without damming up of the river. In the following, the most common types of intakes and structures for small installations will be described. The overhead intake which is suitable for low-head power plants for energy production on large rivers will not be described here in detail. As regards smaller intake structures for small irrigation projects, small hydro-power plants, etc., the description will be limited here to the lateral intake with and without damming, and the bottom intake.

2.3.2 Lateral intake with damming up of the river

A lateral intake with water damming normally consists of two structures, the weir and the intake. The individual elements of the structures can be seen in Fig. 20. The individual structures and their elements have the following functions:

Weir

The weir is situated in the river and its function is to dam up the water level in order to ensure a constant minimum depth of water upstream of the weir and to allow the quantity of water for operational purposes (amount of service water) Q_A to be diverted from the river irrespective of the regime.

Fig. 21 shows the elements of the fixed weir. It consists of

- the actual weir body or the weir sill,
- the structure for energy dissipation: race floor, stilling basin with positive end sill, if necessary,
- the scour protection in the tail water in the area of transition between the structure and the natural river bottom.

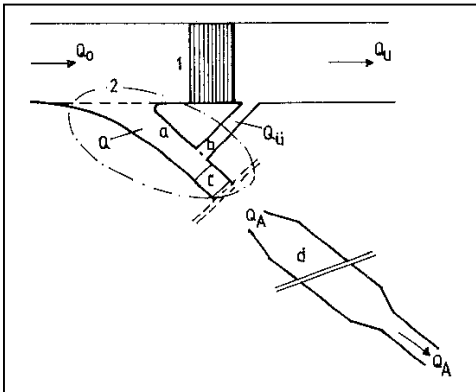

Fig. 20: Elements of intake structure with damming. 1 retaining weir, 2 lateral intake, a forebay, b side weir and flood relief canal, c intake sluice/weir, d sand trap or direct connection to diversion canal

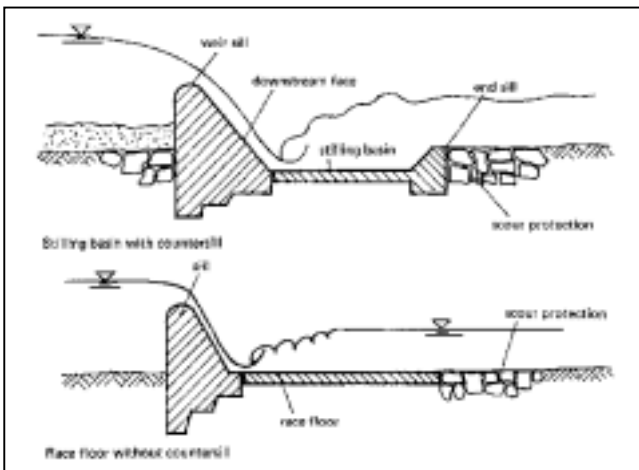

Fig. 21: Elements of a fixed weir

For reasons of economy, only fixed weirs are suitable for intake structures on small and medium-sized rivers for the tapping of relatively small amounts of water, as then maintenance is simple, local construction materials can possibly be used, and repairs be carried out by local staff. In Fig. 22 different types of weirs are shown which will be described in detail in the following:

- Wooden weirs

The timber dam in Fig. 22 is suitable for construction heights up to 1.80 m. The dam wall must be sealed by staggered boards or by foil arranged inside. If the stream or river transports large quantities of bed load and suspended matter, a gradual sealing by the solids deposited can be expected. The race floor must be covered with thick planks or stones in order to prevent scours.

- Crib weirs

Crib weirs (Fig. 22) are suitable for greater impounding heads (up to 3 m) and have also proved their worth for rivers and streams which transport large quantities of bed load and suspended matter. They consist of wooden beams stacked at right angles and bolted, and filled with stones or bed material from the river. The front dam wall must be as tight as possible so that the weir is not destroyed by water flowing through it. To achieve this, staggered boards with foil between them can be used. According to the type of subsoil, the weir should be anchored with stone bolts (rock) or piles (subsoil into which piles can be driven). When the piles are driven close together, the front row may serve as sheet piling to reduce under seepage. Where piles cannot be driven into the soil, the weir must be very long so as to obtain a long seepage line in order to reduce the buoyant forces due to the uplift (cf. also section 2.5).

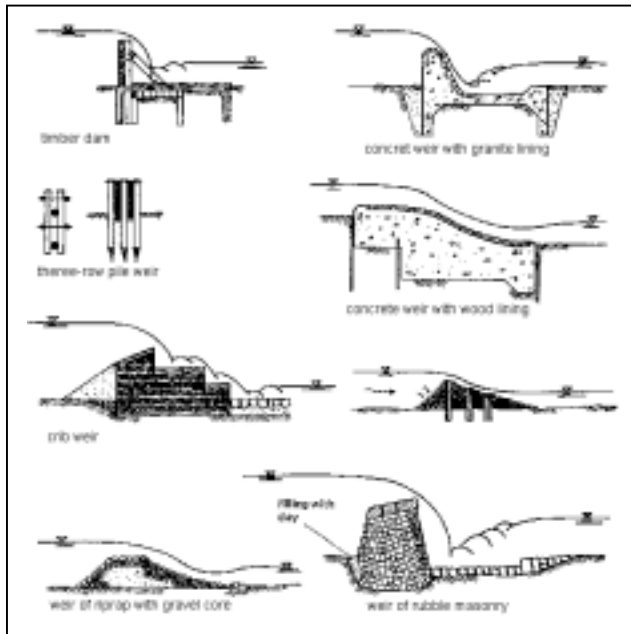

Fig. 22: Different weir types of wood, masonry and concrete

- Stone or concrete weirs

Smaller impounding heads (< 1.50 m) can be reached with weirs of riprap and gravel core. The surface must consist of closely set press stones which offer sufficient resistance to the current. If the weir body is made of concrete, the weir surface should be paved with heavy granite blocks in order to avoid damage to the weir. For streams and rivers with coarse bed load, it is recommended that the downstream face of the weir be paved with hard wooden blocks. This lining of the weir surface has proved its worth, as in the case of too strong abrasion or damage, individual wooden blocks are relatively easy to replace. The blocks are placed in the mortar bed with the grain of the wood at right angles to the current. As wood placed in a dry state expands, this surface lining is very strong.

Intake structure

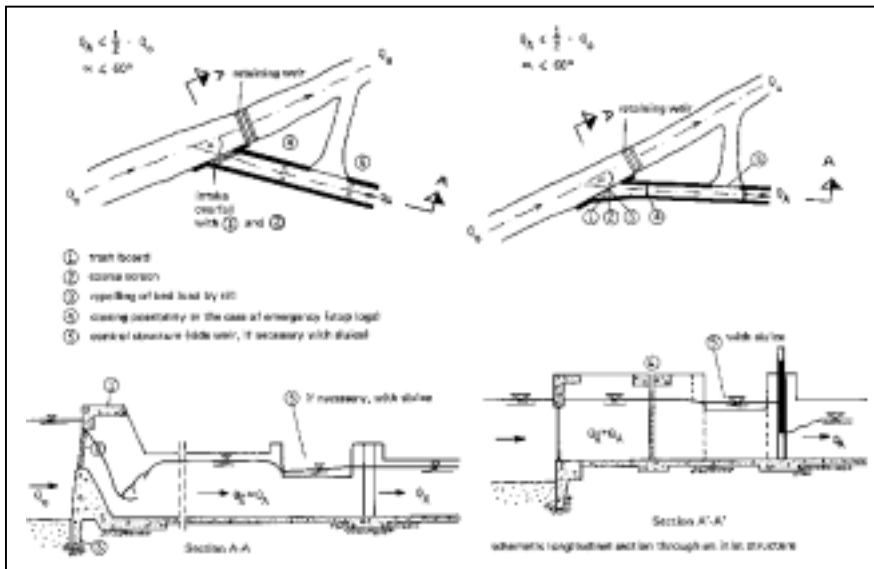

Fig. 23: Schematic potential arrangement of elements of an intake structure

According to the factors influencing the river and the amount of water to be diverted, the intake structure consists of the following elements:

- For intakes of less than 50% of the discharge of a river, the subdivision is shown in Fig. 23:
 - (1) Trash board to keep off floating matter.
 - (2) Coarse screen with a distance between the tears of 10 to 30 cm.
 - (3) Sill to keep off the bed load, construction height about half the height of the arithmetic mean water level when the water is dammed by a weir.
 - (4) Emergency gate at the inlet. Simple stop valves are arranged as emergency gates to allow the structures and elements situated in the tail water to be cleaned and repaired. Stop logs are suitable for this purpose which are guided in a stop log groove (recess on the left and right-hand side of the canal wall) and pressed by the water pressure against a seal in the groove. Fig. 24 shows such a stop log gate. The underside of each beam should also be provided with a seal so that the stop valve is absolutely watertight.
 - (5) Control structure. The intake structure is designed for a certain amount of water Q_A for a specific water level in the river. At higher water levels (periods of flood, etc.), owing to hydraulic phenomena, amounts of water larger than the design amount flow into the diversion canal. This is why a control structure for limiting the amount of water is to be provided enabling the excess water to be directly fed back into the river. A long side weir is a simple solution. However, a side weir allows only a certain portion of the discharge to be diverted. To achieve an exact limitation of the discharge in the canal to Q_A , several side weirs of different length and sill height would have to be arranged one behind another, resulting in a very long structure. By means of a control sluice in the canal downstream of the side weir, it is possible to achieve a greater excess head at the side weir and ensure a higher discharge capacity. A simple sliding sluice is suitable as control sluice (Fig. 25). Such a sluice is operated manually by a crank or a spindle. The latter is then arranged on the loadbearing system above the sliding sluice. When the sluices are designed and constructed, it should be borne in mind that the sluice must be pressed down by the higher sliding friction and the buoyancy during the lowering operation and possibly cannot be lowered by its dead weight alone. For the transmission of force for the lifting and lowering operations, the sluice is therefore equipped with racks which ensure the adhesion. The sluice is brought into the desired position with the crank and the spindle.

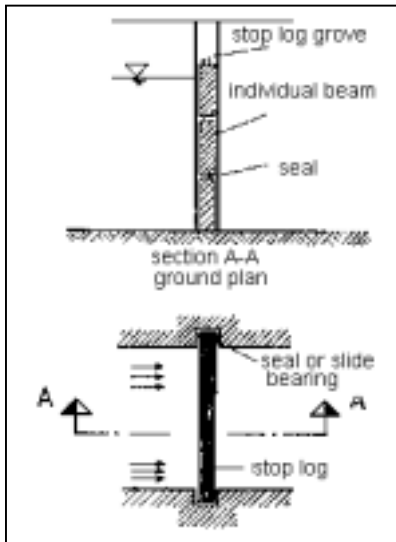

Fig. 24: Emergency gate

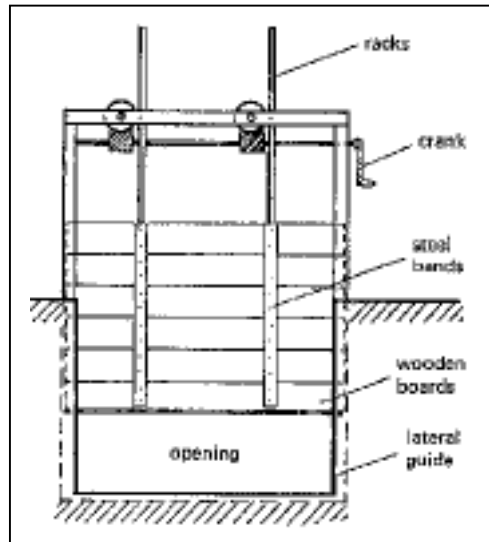

Fig. 25: Sliding sluice

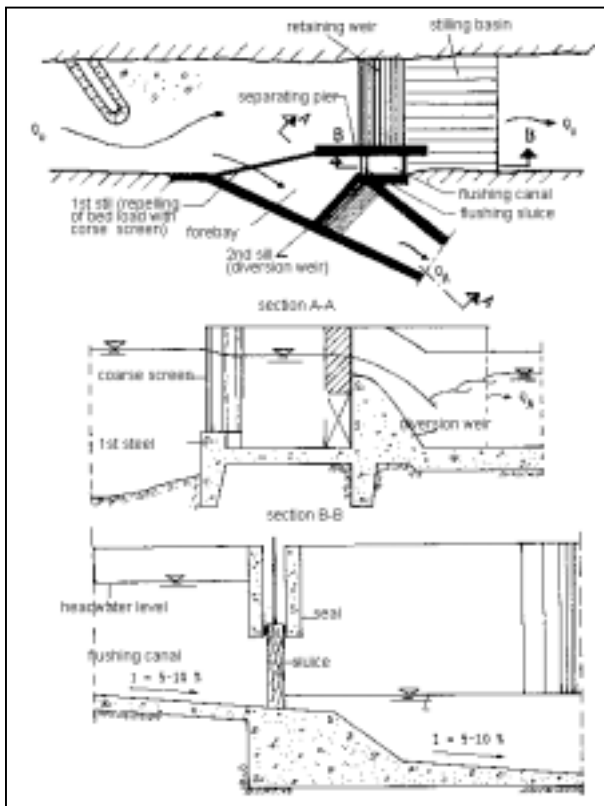

Fig. 26: Example of an intake structure and flushing canal for bed load removal ($QA > 0.5 \cdot Q_0$) - basic sketch

- If more than 50% of the water is diverted from the stream or river, a bed load transport towards the intake structure must be expected due to the stronger deflection of the current in the direction of the intake structure. To prevent bed load from entering the diversion canal, an arrangement of flushing canals as proposed in Figs. 26 and 98 should be considered. These flushing canals must always have a bottom slope of at least 5%. As shown in Fig. 25, in order to minimize or prevent the entry of bed load in the forebay, it can be kept off by a first sill in front of the intake structure. If bed load still passes over this sill into the forebay, these deposits are led to the downstream side by intermittent flushing after a sluice in the flushing canal has been opened.

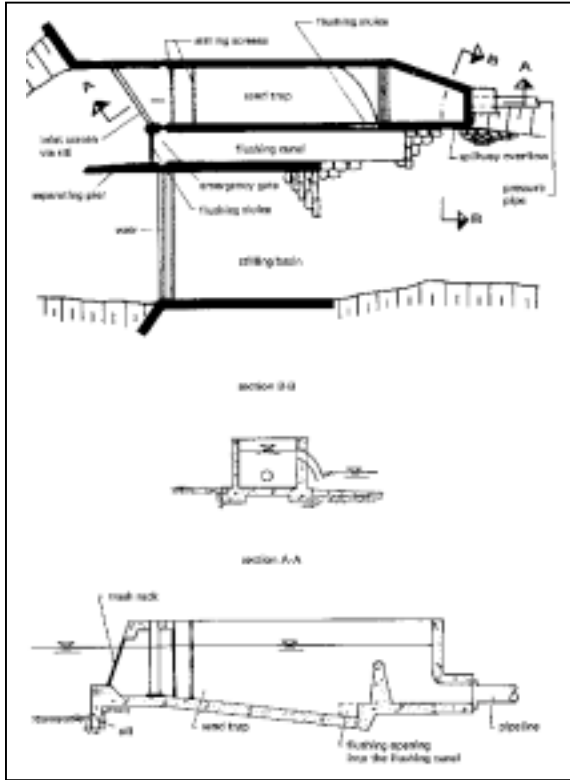

Fig. 27: Intake structure for a small hydroelectric power plant with sand trap and bed load removal (flushing canal) - basic sketch

Fig. 27 shows the arrangement of weir, flushing canal and sand trap with the direct connection of a pressure pipe. This intake is suitable for the diversion of water without a power canal. Before entering the sand trap the bed load is kept off by a sill and led off to the downstream side by intermittent flushing after a sluice has been opened in the flushing canal. The sand trap is flushed by opening a flushing sluice at the end of the sand trap. Here, a spillway overflow in the form of a side weir can be constructed in order to feed excess amounts of water (closing of the turbines, flood) back into the river bed.

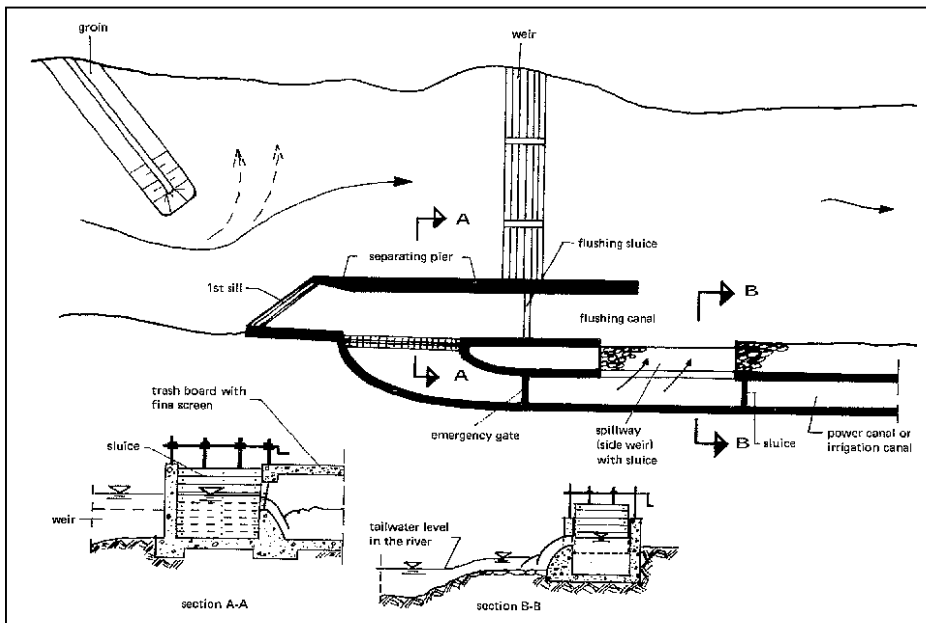

Fig. 28: Intake structure with bed load removal (flushing canal) and spillway (side weir) - basic sketch

In Fig. 28 the bed load is kept off by a first sill in front of the flushing canal. Solid matter that has been deposited in the flushing canal can be led off to the downstream side by intermittent flushing after a sluice has been opened. The intake structure in the form of a side weir prevents bed load from entering the power canal.

If an excess amount of water enters the canal via the intake structure during a flood event, this is fed back into the river via a spillway (side weir, possibly with sluice in the canal to achieve a higher excess head) before it can enter the power canal.

2.3.3 Lateral intake without damming

In most cases lateral intake without damming is suitable only for the diversion of small amounts of water.

The inflow into the intake structure which is arranged laterally (Fig. 18) is directly dependent upon the water level in the river. According to the minimum regime of the river, the inflow is thus limited in quantity. Another limiting factor is that in the channel line the river bottom is normally situated at a lower level than the inlet bottom on the bank, with the result that in the inlet area, the excess head is smaller than the actual water depth of the river.

The limit up to which such intake structures are suitable is formed by an amount of water to be diverted of $1 \text{ to } 2 \text{ m}^3/\text{s} \ll Q$.

These few remarks already show that this type of intake without damming is suitable only in a few cases. In many cases it is nevertheless advantageous to dispense with damming in order

- to avoid an encroachment on the discharge in the case of insufficient knowledge being available of the hydrological phenomena,
- to avoid generating backwater to the upstream side and having to construct expensive jetties,
- to avoid aggradation in front of the dam in the case of rivers transporting a great quantity of bed load (often connected with a breakage of the weir body).

The disadvantages of leaving the river undammed can be compensated by constructional measures. The water is fed into the inlet area with the aid of a repelling groin to be constructed.

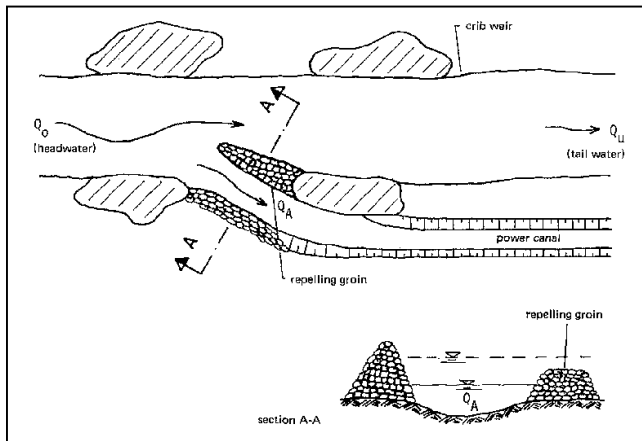

Fig. 29: Simple intake structure without damming with repelling groin

A typical intake structure with repelling groin is shown in Fig. 29. The water is diverted from a stream or river into the canal by a groin consisting of stones piled up in the river (repelling groin).

At times of medium and lowest discharge, when the river does not transport bed load or only small amounts of it, the diversion canal is not loaded by bed material. At times of the highest discharge when the bed load transport increases, the piled up stones of the repelling groin are entrained by the water, i.e. the groin is torn down so that the bed load can be freely transported by the river without hindrance. As the amount of diverted water is small in proportion to the amount of river water in the case of flood ($Q_A \ll HQ_0$), scarcely any bed load is transported into the inlet area. After the flood has subsided at the end of the rainy season, the repelling groin should be restored in order to ensure that water to be diverted is again introduced into the power canal at times of low discharge.

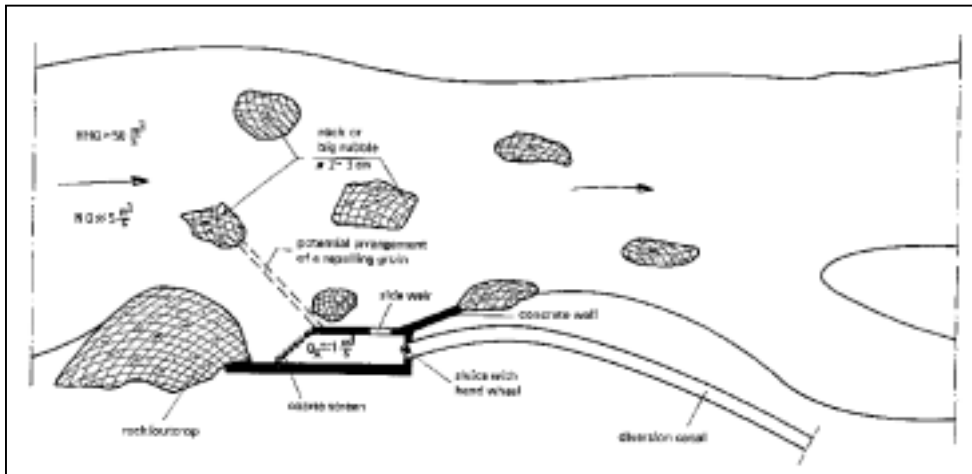

Fig. 30:
Lateral intake
without
damming -
basic sketch

Another method which has proved to be of practical value is to protect the intake structure by rock escarpments. Fig. 30 shows a typical arrangement. Owing to the small amount of diverted water in proportion to the discharge during the rainy season, bed load is scarcely introduced into the area of the intake structure, the more so as the intake structure is protected from the direct approach of water by the outcropping rock nose. When the discharge is at its lowest, the river carries almost no bed load at all, and the canal is therefore not loaded by bed material.

In periods of extreme drought, a repelling groin can be set up to ensure that the desired amount of water can be diverted.

2.3.4 Bottom intake (Tyrolean intake)

The Tyrolean intake occupies a special position. The water to be diverted is taken in through a collection canal built into the river bottom and covered with a screen (Fig. 31). The bars of the screen are laid in the direction of the current and inclined in the direction of the tail water so that coarse bed load is kept out of the collection canal and transported further downstream. Particles which are smaller than the inside width between the screen bars are introduced into the collection canal together with the water and these must later on be separated from the water for power generation by suitable flushing devices. The bottom intake can be constructed at the same level as the river bottom or in the form of a sill.

For the construction of the bottom intake attention must be paid to the following points:

- massive formation of the concrete body as it is subject to strong abrasion forces,
- recommended angle of inclination b of the screen between 5° and 35° ,
- stable formation of the screen bars,
- sufficient freeboard between water surface in the collection canal and upper edge of the screen (at least $0.25 t =$ maximum water depth in the collection canal),
- sufficient slope in the collection canal to evacuate the solid matter which has entered through the screen, presorting of this matter by the inside width between the screen bars. In planning the dimensions of a Tyrolean intake it must be borne in mind that the whole inflow is taken from the river until the capacity limit of the screen is reached. If this maximum possible draw-off amount is greater than the lowest discharge, the tail water is drained. If the inflow exceeds the screen's capacity limit (e.g. during flood events), the amounts which are not diverted flow through the screen into the tail water. This is why the maximum amount of water for power generation to be evacuated can be more safely limited with a bottom intake than with a lateral intake with fixed weirs.

In Fig. 31 the elements of the intake structure with a Tyrolean weir are shown.

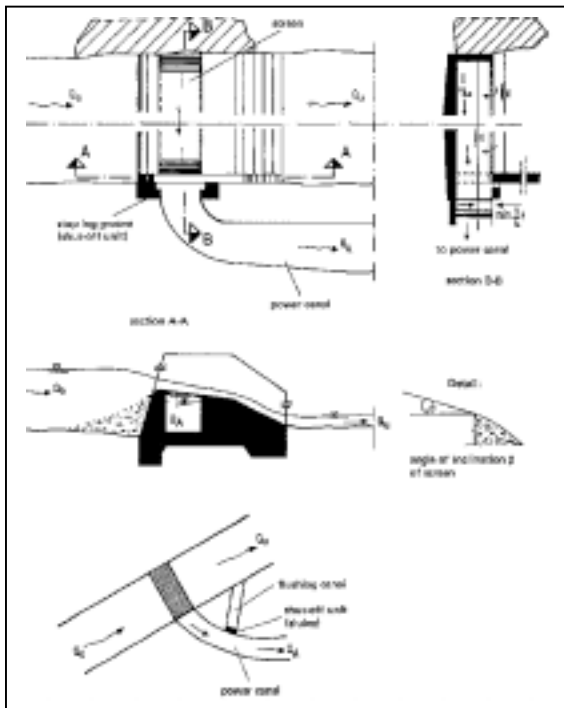

Fig. 31: Tyrolean weir / bottom intake

2.3.5 Selection criteria

In Table 4 (p. 53), the most important criteria for the selection of the lateral and bottom intake are given. The decision for one of the two intake types with a different arrangement of individual components should be taken bearing in mind the local conditions which are particularly influenced by the river's morphology and topography.

Selection criteria	Lateral intake	Bottom intake (Tyrolean weir)
Intake for water power utilization	Quite possible in connection with a sand trap	Quite possible in connection with a sand trap
Amount of water to be taken in	A favourable selection of the intake place will be a necessary prerequisite (outside bend, forcing of an artificial bend by groynes) if the amount of diverted water is greater than 50% of the amount of water supplied.	The bottom screen draws off the river water up to the capacity limit of the screen.
Gradient of river:		
- very great ($I > 10\%$) to great ($10\% > I > 1\%$) gradient	Favourable; an as maintenance-free operation of the intake structure as possible should be ensured.	Very favourable; if the intake structure is well designed, the Tyrolean Weir can prove its worth owing to maintenance-free operation.

- mean gradient (1% > I > 0.01%)	Favourable in connection with a hydraulically very efficient sand trap.	Unfavourable; fine bed load falls into the collection canal and can result in strong alluvial deposits; difficult arrangement of the flushing installation.
- low gradient (0.01% > I > 0.001%)	Favourable in connection with a hydraulically very efficient sand trap.	Unfavourable.
Ground-plan of river:		
- straight	Possible in connection with additional structures (groins for forcing a bent flow).	Very favourable, as bottom screen is uniformly loaded.
- winding	Very favourable when arranged on the outside bend.	Unfavourable, as bottom screen is not uniformly loaded.
- branched	Unfavourable; damming of the river recommended.	Unfavourable.
Solid matter transport of the river:		
- Suspended matter concentration:		
high	Suitable in connection with a hydraulically very efficient sand trap.	Less suitable.
low	Well suited.	Well suited.
- Bed load transport:		
strong	Suitable as long as a sufficient amount of water remains in the river for flushing and transport purposes,	Well suited in the case of coarse bed load; expensive removal in the case of fine bed load with flushing devices.
weak	Well suited.	Well suited.

Table 4: Selection criteria for lateral and bottom intake

3. Hydraulic operation and calculations

3.1 General

In the following, simple methods of calculation are given for the most important structures. The annexes contain numerical examples which make mathematical procedures simple to understand.

The mathematical procedures for the individual components of an intake structure are in many cases the same. Thus the course of calculation and the formulas to be applied are the same for the retaining weir in the river and the free overfall weir in the lateral intake, e.g. between forebay and diversion canal (Fig. 26).

The most important calculations necessary for the design of the intake structure relate to

- free overfall weir as a retaining or diversion weir,
- discharge below a dam wall in the canal,
- free overfall side weir as spillway or as structure for intake on the river bank,
- bottom intake in a special case,
- lateral intake with repelling groin.

Irrespective of whether intake structures are selected with or without damming of the river, the structures should be so designed that

- at times of the lowest discharge, the required amount of water Q_A can always be diverted,
- all floods, including the design flood, can be evacuated without damage being caused to structures or objects, or danger to life and limb,
- the amount of water flowing into the canal is limited to the amount of water to be diverted Q_A . This can be achieved by installing suitable structures in the inlet or by spillways.

The potential effects of river training measures have already been dealt with in detail above. While in the inlet area of a lateral, intake in rivers transporting bed load a weir sill is practically always installed, a sluice is in fact much better suited than a weir for limiting the amount of water flowing into the canal. In the case of both the weir and the sluice, the discharge is directly dependent upon the headwater level. However, while in the case of a weir the discharge increases exponentially with increasing height of the water level above the weir sill' it also increases in the case of a dam wall or a sluice as a function of the opening width, but very rapidly tends to a limiting value with increasing impounding head. Fig. 32 shows a quantitative comparison between the discharge over a weir and the discharge below a dam wall at the same height h_0 in the headwater.

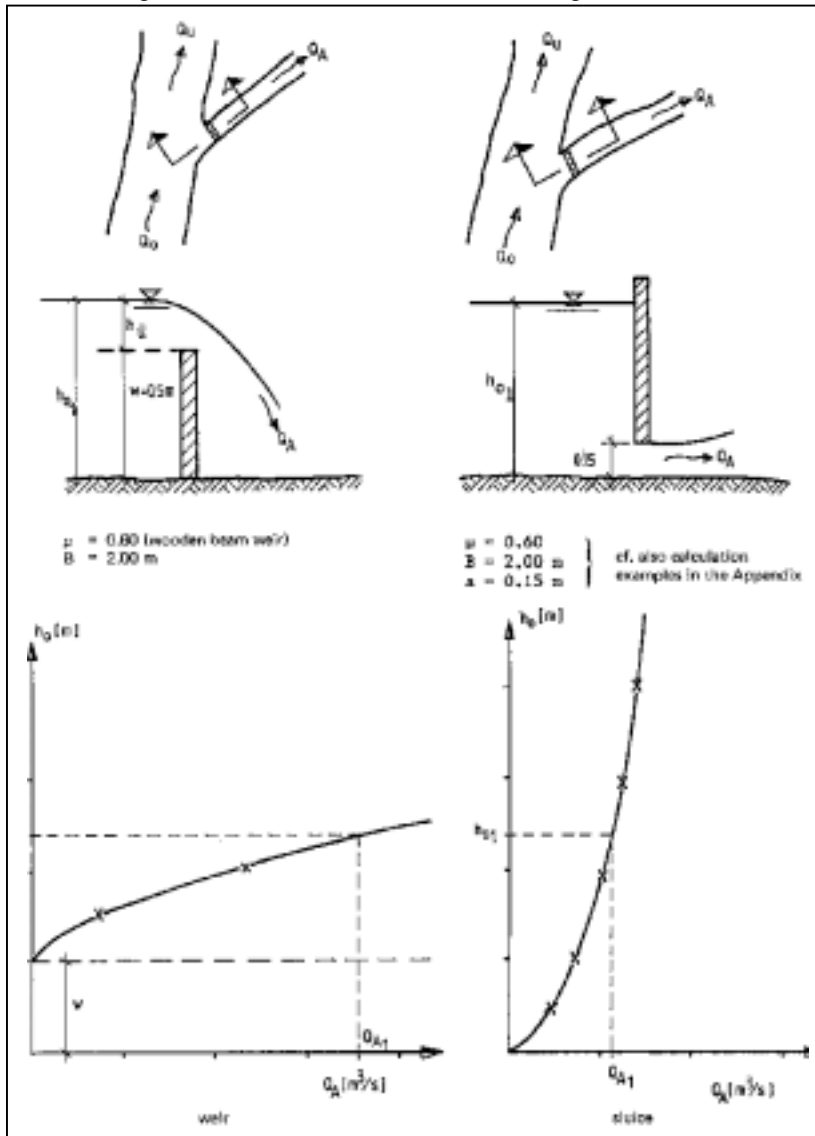

Fig. 32: Limitation resp. evacuation of diverted water through a weir or a sluice

3.2 Hydraulic calculation of the free overfall weir

For calculation purposes, the intake structure or weir is assumed to be as schematically represented in Fig. 33. If the weir is constructed at right angles to the river or the intake so that the water's approach is vertical, the discharge over the weir can be determined by means of the following formula:

<<l>> p056.png Fig. 33: Dimensioning of fixed weirs

Weir formula (or Poleny formula)

$$Q = \frac{2}{3} \cdot c \cdot \mu \cdot b \cdot \sqrt{2g} \cdot h_u^{3/2} \text{ (in m}^3\text{/s)}$$

The symbols are as follows (cf. Fig. 33):

Q = discharge over the downstream face in m³/s, c = correction factor for submerged overfall, μ = weir coefficient, b = weir crest width in m, g = acceleration due to gravity = 9.81 m/s², h_u = weir head in m.

- Weir coefficient μ

This coefficient depends upon the crest form of the weir. In Fig. 33 the coefficients are given for the most typical crest forms. For the construction of weir bodies with vertical headwater side in rivers transporting a large amount of bed load, it should be remembered that after a prolonged period of operation, this weir will have the same effect as a broad, round-crested weir due to the alluvial deposits in front of the weir face. In this case, the discharge capacity would be smaller due to the smaller weir coefficient.

- Correction factor c

The correction factor c allows for the influence of the tail water level upon the discharge over the weir:

- for the free overfall c = 1,
- for the submerged overfall, c is to be taken from the graphical representation in Fig. 33.

Whether an overfall is free or submerged depends upon the height of the tail water level in relation to the position of the weir crest (Fig. 34).

- If h' < 0, the overfall is free.
- If h' > 0 and if there is a limiting depth t_{limit} above the weir crest, the overfall is submerged.
- If h' > 0 but the discharge flows over the weir crest, the overfall is submerged.

For the design of a weir, in most cases the height of the weir crest at a given weir length (e.g. width of the river/canal) must be found. For this purpose, the following quantities and dimensions in accordance with the weir type (retaining weir or diversion weir) must be specified or known:

Retaining weir

- maximum discharge (flood event) over the weir
- maximum permissible headwater level h₀
- weir type with weir coefficient tail water level h_u when the maximum discharge is evacuated

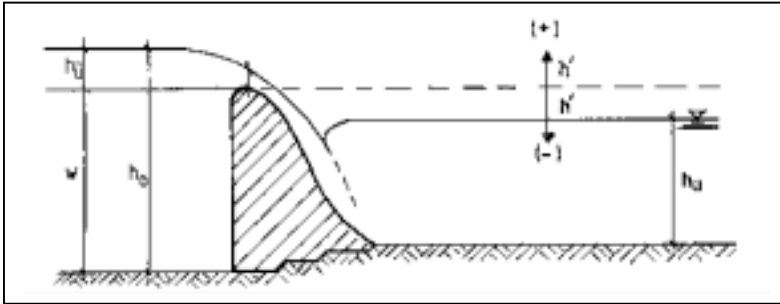

Fig. 34: Discharge over a weir

Diversion weir

- minimum amount of water to be diverted
- minimum headwater level h_0
- weir type with weir coefficient
- tail water level h_u when the minimum amount of water to be diverted is evacuated

If these data are available, the weir head h_u of the retaining weir in the case of flood (maximum load) can be determined. The weir body height is then

$$w = h_0 - h_u$$

This allows the elevations of the water surface in the river upstream of the weir to be determined by the weir formula for any discharge. The weir crest of the intake structure must be high enough so that at the lowest discharge, the required amount of water for power generation is evacuated over the diversion weir by a sufficient weir head (cf. Fig. 35).

Numerical examples of the calculation of a free and submerged overfall weir as well as an overfall over a weir with stilling basin or race floor are given in Annexes 3 to 5.

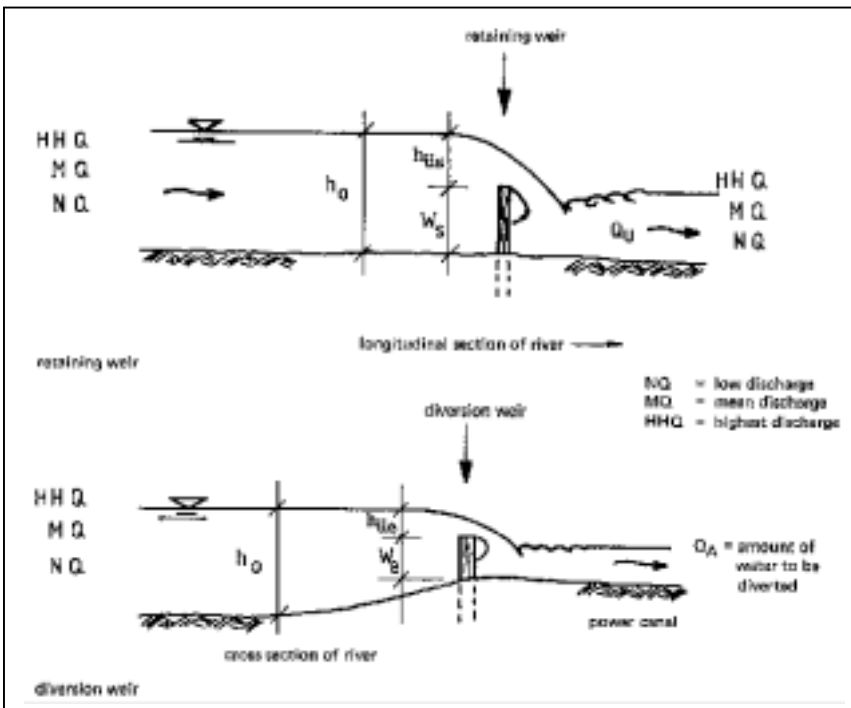

Fig. 35: Relationship between diversion weir and retaining weir

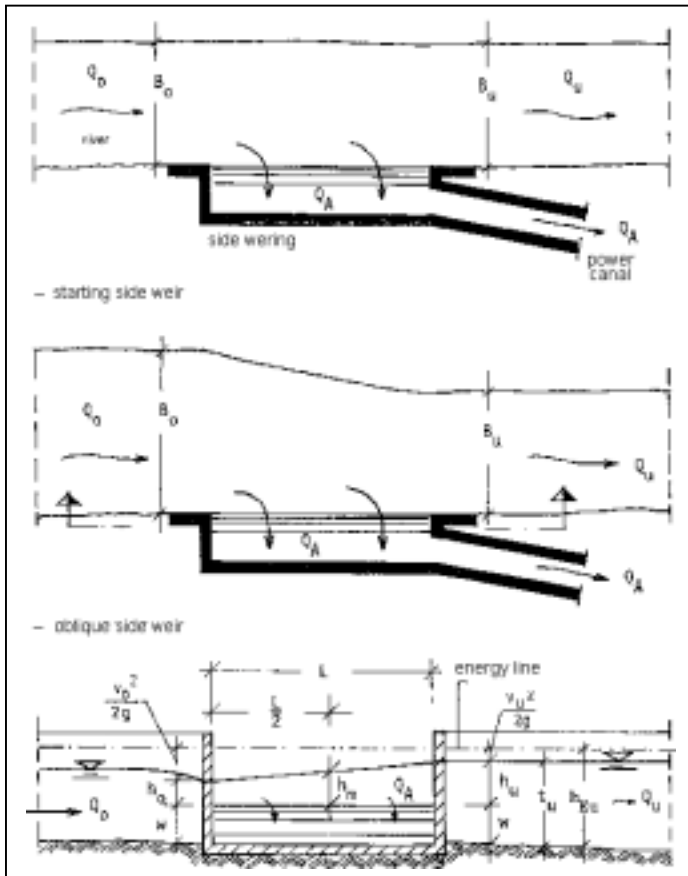

Fig. 36: Principle of the side weir with the hydraulic characteristics. Q_D headwater discharge, Q_U tail water discharge, Q_A evacuated amount of water, w weir height, L weir length, h_0 weir head in the headwater, h_U weir head in the tail water, h_m mean weir head, h_{E_U} energy head in the tail water, $v_{0,U}$ flow velocity in the headwater, tail water

3.3 Free overfall side weir

A side weir (cf. Fig. 36) is always involved when a weir is approached obliquely or is situated parallel to the channel line to evacuate the amounts of water Q_A . This oblique approach occurs when the weir is constructed parallel to the river bank or power canal, for example. The calculation of the discharge capacity of a side weir is made with the following weir formula:

$$Q = \frac{2}{3} \cdot c \cdot \mu^x \cdot L \cdot \sqrt{2g} \cdot h_m^{3/2} \text{ (in m}^3\text{/s)}$$

where L = length of side weir in m, h_m = mean weir head in m, μ^x = reduced weir coefficient = $0.95 \cdot m$ (for m cf. Fig. 33), c = correction factor (cf. also section 3.2).

An important prerequisite for the application of this formula is that the discharge in the headwater be a flowing one. This condition is fulfilled when Froude's number is smaller than 0.75:

$$F_0 = \frac{V_0}{\sqrt{g \cdot (h_0 + w)}} \leq 0.75$$

where v_0 = velocity in the headwater in m/s,

$$V_0 = \frac{Q_0}{B_0 \cdot (h_0 + w)} \quad (\text{in m/s, for the symbols cf. Fig. 36}),$$

g = acceleration due to gravity = 9.81 m/s²,

h_0 = estimated weir head at the beginning of the side weir in m (cf. calculation example in Annex 6),

w = weir crest height in m.

In the place of the weir head h , a mean weir head h_m in m is used. It is the mean value of the smaller weir head h_0 at the beginning of the side weir which increases along the downstream face up to the maximum weir head h_u at the end of the side weir. The weir head h_u is determined by the discharge characteristic of the river or canal, i.e. it corresponds approximately to the difference between the given tail water level t_u and the weir crest height w .

$$h_u = t_u - w \quad (\text{in m})$$

The weir head h_0 must first be estimated. For this purpose, the known or determined quantities such as weir crest height w , tail water level t_u , inflow to the headwater Q_0 , and headwater width B_0 are introduced into the formula

$$(h_0 + w)^3 - h_{Eu} \cdot (h_0 + w)^2 + \frac{\alpha \cdot Q_0^2}{2g \cdot B_0^2} = 0$$

with the energy head

$$h_{Eu} = t_u + \frac{V_u^2}{2g} \quad (\text{in m/s, cf. Fig. 36})$$

$$V_u = \frac{Q_u}{t_u \cdot B_u} \quad (\text{in m/s})$$

$\alpha = 1.1$ velocity coefficient

and solved iteratively. After the weir head h_0 has been determined, the mean weir head

$$h_m = \frac{h_0 + h_u}{2} \quad (\text{in m})$$

is calculated and the value n read off from the diagram in Fig. 37 as a function of h_m and $Q_u > 0$ (residual amount of water in the tail water) and/or $Q_u = 0$ (case: confined tail water; this is the case when the main flow is confined by a sluice and all the water is led over the side weir: $Q_A = Q_0$). This value n is multiplied by α and yields the new value

$$\alpha = n \alpha \quad (\alpha = 1.1)$$

In the above-mentioned formula, this new value α replaces the former value $\alpha = 1.1$ (n results from Fig. 37).

Repeating the iterative solution of this equation using α we obtain an improved estimated value of h_0 .

With the mean weir head then determined, the weir length is

$$L = \frac{3}{2} \cdot \frac{Q_A}{c \cdot \mu^x \cdot \sqrt{2g} \cdot h_m^{3/2}} \text{ (in m)}$$

The procedure is shown systematically in the following. A numerical example is given in Annex 6.

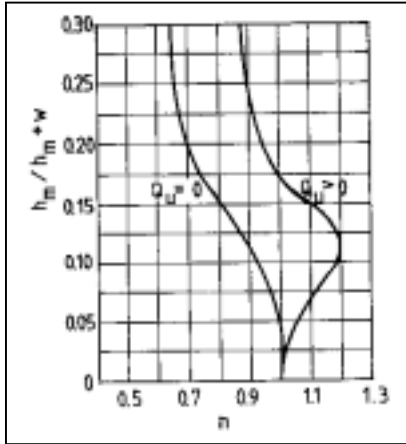

Fig. 37: Correction factor n for side weir calculation

3.4 Outflow below a dam wall (sluice)

The calculation of the outflow below a dam wall or a sluice is one of the most common tasks of hydraulic engineering. As compared with the relatively small openings for bottom outlets of dams, the width of the outflow opening for the outflow below the sluice can be considered large compared with its height. In these cases, the discharge can be dealt with as a two-dimensional flow problem and calculated with the following formula:

$$Q = k \cdot \mu \cdot a \cdot B \sqrt{2 \cdot gh} \text{ (in m}^3\text{/s)}$$

where k = correction factor for submerged discharge; for free discharge $k = 1$ (cf. Fig. 38), μ = discharge coefficient; this coefficient chiefly takes the jet contraction into account, a = height of the outflow opening in m, B = width of the outflow opening in m, h = impounding head in front of the sluice or the dam wall in m, g = acceleration due to gravity = 9.81 m/s².

The discharge coefficient for the vertical sluices which are most frequently used depends upon h/a

$$\mu = 0.55 - 0.60 \text{ (limiting value)}$$

For rough dimensioning, a value $\mu = 0.6$ can be assumed.

The correction factors k for the submerged discharge are given in Fig. 38. For free discharge, i.e. when the tail water is not an influencing factor $k = 1$.

The tail water is an influencing factor when the shooting jet is impounded at the sluice opening directly behind the sluice (cf. Fig. 38). This discharge behaviour is dependent upon the tail water level (and, thus, upon the dimensioning quantities of the power canal, the headwater level and the sluice opening).

For the dimensioning of the outflow below a sluice, mainly the following quantities are specified or must be fixed:

- height of the sluice opening a (is fixed),
- headwater level (minimum, maximum), known from the canal calculation,
- tail water level h_u (dependent upon the amount of water to be evacuated and upon the dimensioning of the tail water canal),
- sluice width B , dependent upon the canal width.

With the formula given above, Q_A can now be determined. It must first be ascertained whether or not the discharge is free.

For this purpose the ratio h/a is formed.

From Fig. 38d), with, for example, $\sigma = 0.7$ for h/a , the limiting value h_u/a limit. is determined.

The discharge is free when

$$\frac{h_u}{a} \text{ exist.} < \frac{h_u}{a} \text{ limit.}$$

Q_A is then determined for the conditions assumed. In most cases, however, the necessary amount of outflow Q_A is known, and therefore only the height of the sluice opening a must be determined.

After these quantities have been fixed, the sluice openings a necessary for the evacuation of the corresponding amounts of water can be determined.

For this purpose, the above-mentioned formula must be transformed with respect to:

$$a = \frac{Q_A}{k \cdot \mu \cdot B \sqrt{2gh}}$$

The following procedure is followed:

- If there is a free discharge (i.e. $k = 1$), the formula given above is used to determine a .
- h/a is formed and the limiting value for h_u/a is ascertained in accordance with Fig. 38d).
- Exist. h_u/a is compared with h_u/a limit. If $h_u/a < h_u/a$ limit., the assumption is correct. The calculation is complete. If the assumption is not correct, the calculation is continued.
- For $h_u/a > h_u/a$ limit., the k value for exist. h_u/a is determined with the curve for h/a from Fig. 38e).
- With this k value $Q_{A\text{exist.}}$ is calculated; it proves to be smaller than Q_A determined
- In order to evacuate $Q_{A\text{determ.}}$ a must be increased. In first approximation, $a_{\text{new}} = a/k$.
- Now h/a and h_u/a are again checked in accordance with Figs. 38d) and e).
- The k values and the values a_{new} and a_{old} are compared.
- The calculation is repeated by a new adaptation, if necessary, until the deviation is small and Q_A can be evacuated.

Numerical examples are given for both cases in Annex 7.

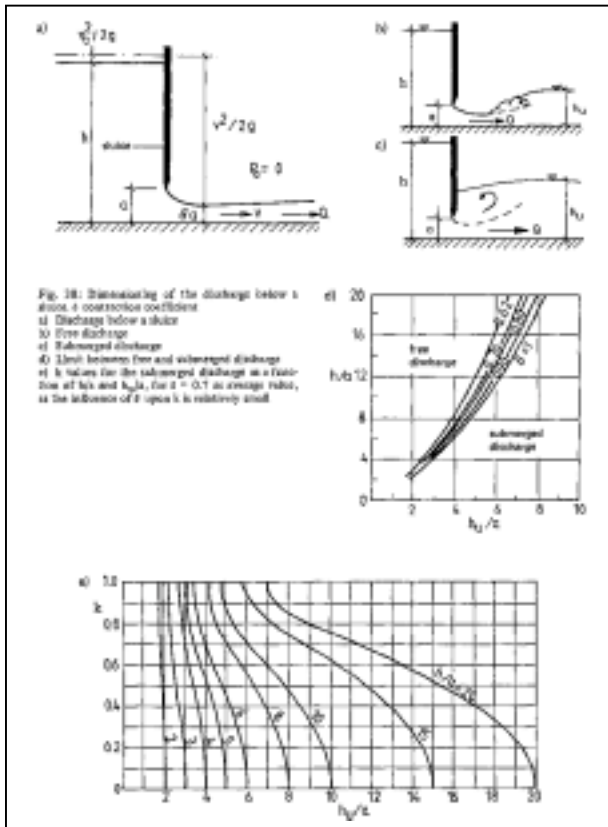

Fig. 38: Dimensioning of the discharge below a sluice, δ contraction coefficient

a) Discharge below a sluice
 b. Free discharge
 c) submerged discharge
 d) Limit between free and submerged value
 e) k value for the submerged discharge as a function of h/a and h_u/a , for $\delta=0.7$ as average value, as the influence of δ upon k is relatively small.

3.5 Intake with a repelling groin

For this arrangement of the lateral intake, an exact hydraulic determination of the evacuated amounts of water for power generation is not possible, as the inflow into the side canal (power canal) with the aid of a repelling groin very much depends upon the flow conditions and thus also upon the water level in the river.

The rating curves of the river and the canal (relation between water level and corresponding amount of discharge in a river/canal) allow only the approximate amounts of water for power generation to be estimated (cf. Fig. 39).

The amounts of water for power generation are obtained from the water level of the river and of the canal which is identical in the inlet area, thus allowing a value to be estimated for the corresponding discharge.

3.6 Hydraulics of the bottom intake (Tyrolean intake)

In the case of a vertical approach to a Tyrolean intake (cf. Fig. 40), amounts of water partially obstructed by the trash rack - fall into a collection canal which is intended to evacuate the water laterally. With this, a water level similar to that shown in Fig. 40 is formed above the trash rack.

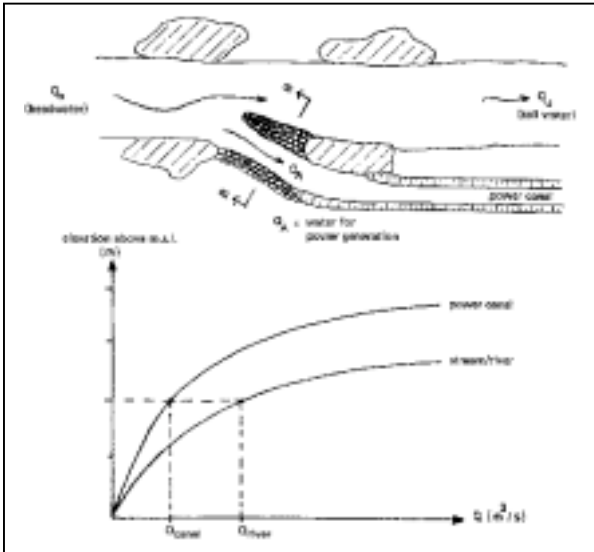

Fig. 39: Lateral intake with repelling groin

The following weir formula is used for the design of a Tyrolean intake:

$$Q = \frac{2}{3} \cdot c \cdot \mu \cdot b \cdot L \sqrt{2gh} \quad (\text{in m}^3/\text{s})$$

where (cf. also Fig. 40) Q = discharge to be diverted in m^3/s , $h = k \cdot h_{\text{limit}}$, $= 2/3 k h_E$ = "initial water height" in m, $c = 0.6 b \cos^{3/2} \alpha$

with a = inside width between trash rack bars in m, d = centre distance of the trash rack bars in m, b = angle of inclination of the trash rack with respect to the horizontal in $^\circ$, μ = discharge coefficient for the trash rack, b = width of the Tyrolean intake in m, L = length of the trash rack in m. The various coefficients can be taken from Fig. 40.

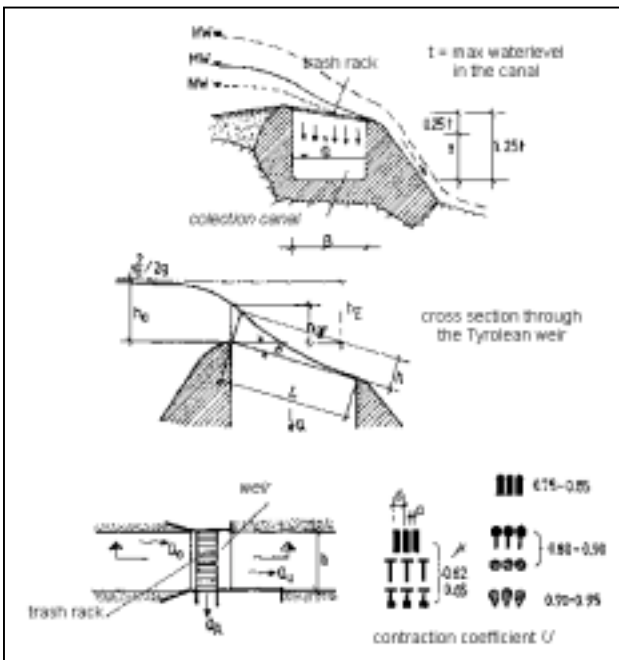

Fig. 40: Design of a bottom intake (Tyrolean weir)

β	χ	β	χ
0°	1.000	14°	0.879
2°	0.980	16°	0.865
4°	0.961	18°	0.851
6°	0.944	20°	0.837
8°	0.927	22°	0.825
10°	0.910	24°	0.812
12°	0.894	26°	0.800

values k

The oblique arrangement of the trash rack prevents it from being clogged by bed load or floating matter and the intake from being obstructed. The Tyrolean intake is particularly suitable as an intake structure in rivers transporting bed load. In order to guarantee the diversion of the minimum amount of water when stones become wedged in the trash rack, or branches and leaves remain on the trash rack at low water levels, the trash rack should be

selected $L = 1.2 \cdot L_{\text{calculated}}$

The collection canal should be designed according to the following principles:

- The canal width should correspond approximately to the length L of the trash rack.
- Exactly: $B = L \cos b$, b = angle of inclination of the trash rack bars with respect to the horizontal.
- The canal depth for the evacuation of the water should approximately correspond to the canal width: $t \sim B$.
- The canal depth is to be so determined that a freeboard of approx. $0.25 \cdot t$ (t = water depth necessary for the evacuation of the water!) remains up to the upper edge of the trash rack. If the water cannot be evacuated in accordance with the above recommendations, either the gradient or the water depth t of the collection canal must be increased.
- The amount of water for power generation is limited by the capacity of the canal cross-section.

A calculation example is given in Annex 8.

4. Necessary proofs of stability

In the investigation into the stability of fixed weirs and other structures subject to underflow, proof of safety with regard to sliding and hydraulic shear failure must be given.

4.1 Prevention of hydraulic shear failure

To prevent hydraulic shear failure, the critical hydraulic gradient

$$I_{crit.} = (1 - n) \cdot \left(\frac{\gamma \cdot F}{\gamma \cdot w} - 1 \right)$$

must be twice the existing hydraulic gradient

$$I_{exist.} = \frac{\Delta h}{n_s \cdot \Delta n_s} = v = \frac{I_{crit.}}{I_{exist.}} \geq 2.0$$

where γ_F = specific weight of the soil particles/of the soil in situ kn kN/m^3 , γ_W = specific weight of water, about 10 kN/m^3 , n = pore volume proportion, Δh = difference in water level between headwater and tail water in m, n_S = number of potential lines, Δn_S = distance between two neighbouring potential lines in m.

Empirical values for γ_F

- sand/gravel	20 kN/m^3
- rubble with sand	19 kN/m^3
- clay	20 kN/m^3
- sandy clay/clayey sand	21 kN/m^3
- silt	19 kN/m^3

Empirical values for n :

- sand/gravel	35%
- rubble with sand	45%
- clay	60%
- sandy clay/clayey sand	45%
- silt	45%

To determine the number of potential lines, the stream and potential line net must be constructed as follows:

Marking of the stream lines around the structure subject to underflow (cf. Fig. 41). Here the following points must be observed:

- The topmost stream line is represented by the foundation of the structure or the sheet piling (straight BC-DC) and the bottommost stream line by the surface of the watertight layer (if such a layer exists) (straight FG).
- At narrow points of the seepage section the distances between the stream lines are smaller.
- Marking of the potential lines. Here, the following points must be observed:
- At the points of intersection the stream lines and the potential lines must always be vertical to one another.
- The first potential line is the bottom of the headwater (straight AB), the last potential line the bottom of the tail water (straight DE).
- The distance of the centre lines b and 1 kn an individual field is equal.

In the case of structures subject to underflow, hydraulic shear failure can result wherever there are buoyant forces at the end of the foundation due to the seepage flow from the headwater to the tail water (cf. Fig. 42). At times of low water, for example, at a great water level difference D_h , these forces can become so strong that the pressure due to the seepage flow pushes the river bottom area at the end of the weir upwards, and the weir foundation is damaged by headward erosion.

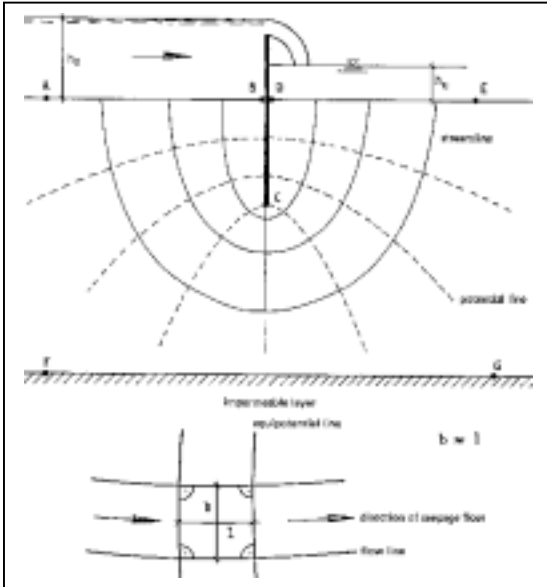

Fig. 41: Construction of a stream and potential line net

The danger of hydraulic shear failure is encountered particularly at times of low water because then the necessary water surcharge is lacking in the tail water and the water level difference h can be very great. The danger of shear failure can be reduced by lengthening the path of seepage below or on the structure or by arranging large stone blocks on the tail water bottom of the endangered area.

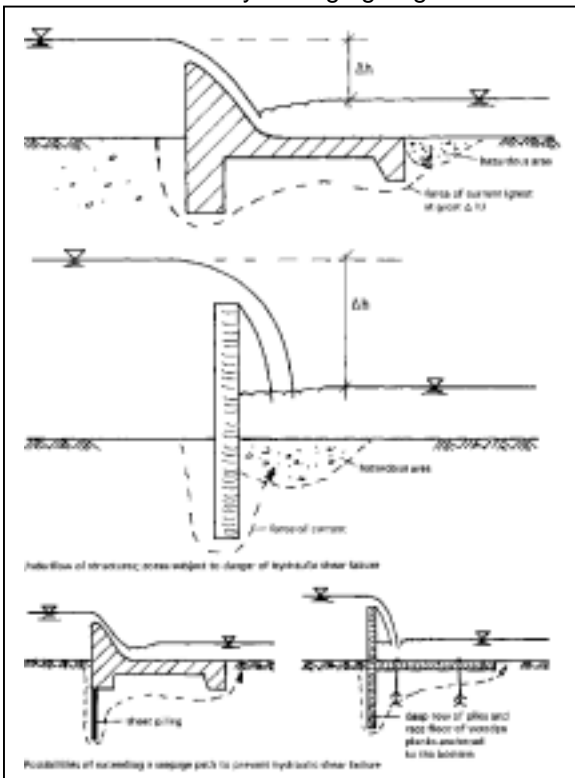

Fig. 42: Risk of hydraulic shear failure at the weir end in the tail water area

To lengthen the path of seepage, either a longer weir with a longer race floor can be constructed or sheet pilings (rows of piles) placed at the beginning and, if necessary, also at the end of the weir foundation (cf. Fig. 42).

A numerical example of proof of safety from hydraulic shear failure is given in Annex 9.

4.2 Stability against sliding

To prove stability against sliding in the foundation area of a fixed weir, the shear strength in the slip joint must be greater than the shear force. The stability against sliding is calculated as follows:

$$G = \frac{V \cdot \tan \phi}{H} = \frac{(G + W_V - A) \cdot \tan \phi}{W_H + P_G} \geq 1.5$$

where V = vertical forces: G = weight of the structure in kN, W_V = water surcharge on the structure in kN, A = buoyancy in kN;

H = horizontal forces: W_H = horizontal water pressure in kN, P_G = bed load pressure in kN; $\tan \phi$ = friction coefficient between soil/soil and concrete/soil.

Empirical values for various friction coefficients (concrete/soil):

Noncohesive soils	$\tan \phi$
sand	0.56
gravel	0.60
rubble/stones	0.70

Cohesive soils

clay	0.20
sandy clay	0.30

The buoyant forces due to the uplift below a structure subject to underflow result from the seepage water pressure and the tail water pressure (Fig. 43).

The seepage water pressure is determined for defined points such as structure edges. For this purpose the potential and stream line net of the seepage flow must be drawn. As after each potential line the seepage water pressure decreases in the direction of flow by the amount

$$P_s = \frac{10}{n_s} \cdot \Delta h \text{ (in kN/m}^2\text{)}$$

with n_s = total number of potential steps, Δh = difference between headwater and tail water level in m,

(Fig. 43), the seepage water pressure at a specific point i is

$$P_{si} = \left(1 - \frac{n_i}{n_s}\right) \cdot 10 \cdot \Delta h \text{ (in kN/m}^2\text{)}$$

with P_{Si} = seepage water pressure at the point i being sought in the foundation of the structure in kN/m², n_i = number of potential steps in the direction of flow up to the point i being sought.

The tail water pressure corresponds to the difference in height between the tail water level and the foundation of the structure. (Example: At a tail water level of 1.50 m, the tail water pressure $P_U = 10 \Delta h = 10 \cdot 1.50 \text{ m} = 15 \text{ kN/m}^2$.)

The horizontal forces are made up of the water pressure and the earth pressure of the bed load at the downstream face of the weir.

The horizontal water pressure force per metre of weir width is determined by

$$W_H = \frac{1}{2} \cdot \gamma \cdot w \cdot (h_0^2 - h_u^2) \text{ (in kN/m)}$$

with γw = specific weight of water $\sim 10 \text{ kN/m}^3$, h_0 = headwater level in m, h_u = tail water level in m.

Number of potential lines $n_2 = 44$ (numerical example)

	left lower edge of weir (a)	right lower edge of weir (b)
number of potential lines up to edge	$n_a = 15$	$n_b = 30$
seepage water pressure up to edge	$P_{Sa} \cong \frac{44 - 15}{44} \cdot h \cdot 10 = \frac{29}{44} \cdot h \cdot 10$	$P_{Sb} \cong \frac{44 - 30}{44} \cdot h \cdot 10 = \frac{14}{44} \cdot h \cdot 10$

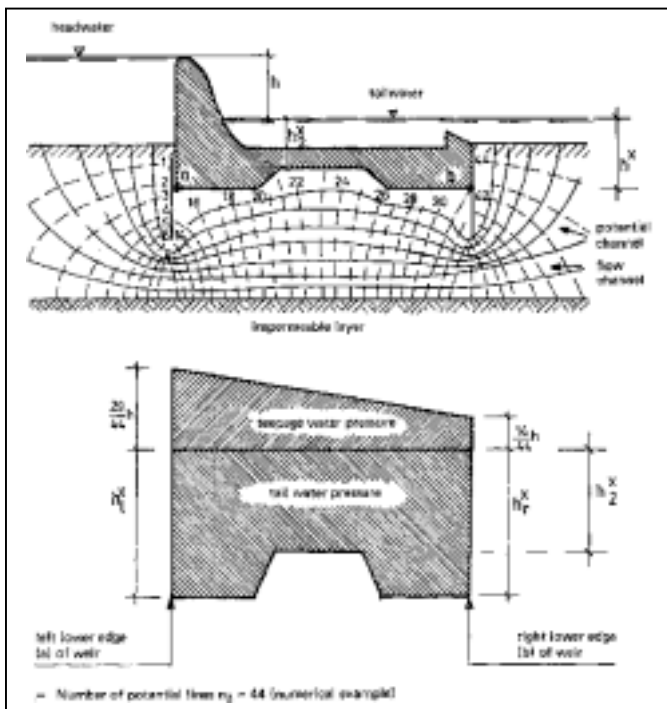

Fig. 43: Bottom water pressure, stream and potential line net in the case of a structure subject to underflow, with 2 sheet pilings

In the case of strong bed load deposits, the bed load pressure force at the downstream face of the weir per metre of weir width is

$$P_G = \frac{1}{2} (\gamma \cdot G - \gamma \cdot W) \cdot W_G^2 \text{ (in kN/m)}$$

with γ_G = specific weight of the bed load in kN/m^3 , γ_W = specific weight of the water $\sim 10 \text{ kN/m}^3$, W_G = height of the amount of bed load at the downstream face of the weir.

Empirical values for specific weights of different soils:

- sand/gravel	20 kN/m ³
- rubble with sand	19 kN/m ³
- clay	20 kN/m ³
- sandy clay/clayey sand	21 kN/m ³
- silt	19 kN/m ³

An increase in the stability against sliding can be achieved by the following measures:

- reinforcement of the foundation (placing at a lower level),
- extension of the weir, particularly of the race floor or of the stilling basin,
- increase in the weight of the weir and · reduction of the seepage water pressure by the arrangement of a toe wall at the beginning and at the end of the structure (lengthening of the path of seepage and corresponding decrease of the seepage water pressure).

A numerical example of the proof of stability against sliding of a fixed weir is given in Annex 10.

5. Sand trap

5.1 Necessity for sand traps

Sand traps are necessary when the suspended matter content of the river water is high and when plant components such as pressure pipes, turbine rotors, slide valves, etc., must be protected from abrasion by hard suspended matter such as quartz sand.

Wear and tear due to abrasion can in a short time result in serious damage and in the case of turbines in a considerable reduction in efficiency. The greater the effective head and, thus, the flow velocity, the greater the danger to the plant components.

It is the purpose of the sand trap to remove the fine-grained suspended matter from the water and to protect the components. This is achieved most simply by allowing the suspended matter to settle in the settling basin or a long sand trap. This is done by slowing down to a low velocity the amounts of water distributed as evenly as possible over the cross-section of the basin. The time of passage through the basin must not be shorter than the settling time of the suspended matter. These boundary conditions require long structures suitably shaped from the hydraulic point of view (cf. section 5.3).

The velocity of the water in the inlet canal of the sand trap must not be low, otherwise suspended matter will be deposited in the inlet canal too soon. The flow into the basin is therefore turbulent. A well-designed transition section should be arranged ensuring a steady and even passage; likewise, stilling screens can be used here and achieve good results (cf. Fig. 44).

5.2 Hydraulic design

5.2.1 Suspended matter content

As the plant components coming into contact with the water such as slide valves, pressure pipes, turbines, rotors and casings are destroyed by the suspended matter, it is necessary to determine its concentration and composition.

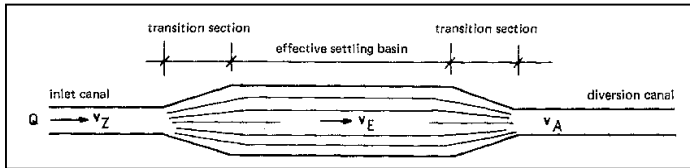

Fig. 44: Schematic representation of a uniformly loaded sand trap

In general, the suspended matter is found to be composed of particles of different sizes. In rivers in the lowland or in the low mountain ranges, the colloidal particles can be of diameters from the mud fraction to the sand fraction (f 0.002 mm to 0.2 mm or ~ 1 mm), whereas in mountain rivers with steep slopes, the particle sizes can be of the order of 2 to 3 mm.

The quantity of suspended matter is expressed by the suspended matter concentration:

suspended matter concentration =

kg suspended matter / m³ water

Suspended matter concentrations (C) are generally

- in lowland rivers $C = 0.1$ to 1.0 kg/m³,
- in mountain rivers/brooks $C = 2.0$ to 10 kg/m³.

According to the nature of the catchment areas (topography, geology, utilization, vegetation), these values can be far exceeded or not reached. Thus the suspended matter concentration in the lower course of the Yellow River in China varies seasonally between 60 and 600 kg/m³ [9].

The suspended matter concentration can be measured by sampling (cf. section 1.3.3) and assessed by inspection (clear water through which the bottom is visible has a low suspended matter concentration whereas turbid, yellowish brown water indicates a high suspended matter concentration).

The suspended matter content varies from season to season and depends upon the precipitation in the catchment area and the regime of the river or stream.

5.2.2 Desanding measure

The desanding measure is expressed by the ratio of the suspended matter concentration of the desanded water for power generation $C_{perm.}$ to the suspended matter concentration C of the river water which has not been desanded:

degree of desanding = $100 C_{perm.}/C$ (in %).

There are no regulations or standards for the selection of the degree of desanding; empirical values which have been derived from the operation of existing hydroelectric power plants are rather taken as a basis.

Decisive criteria for fixing the degree of desanding are:

- minimization of the damage caused by suspended matter (abrasion, etc.) to the plant components.
- sensitivity of the turbines to suspended matter depending upon the turbine type, the diameter of the suspended matter particles, the mineralogical nature of the particles, the effective head.

Experience has shown that

- cross-flow turbines are relatively insensitive to soft impurities such as silts, clays and floating matter such as grass, leaves, etc.
- Kaplan turbines, Francis turbines and Pelton turbines are more sensitive to any kind of suspended matter, the Pelton turbine used in micro. and mini-plants being less severely affected by impurities in the water. It is possible, however, that wear and tear on the buckets sharply increases.

The permissible suspended matter concentration is also determined by the definition of the grain-size limit of the particle which is only just to be separated by the sand trap.

5.2.3 Determination of the grain-size limit

With regard to the above-mentioned criteria and the requirements of operation, the indication of the particle diameter serves to define a limiting size of the suspended matter which is only just allowed to deposit. From experience it may be assumed that:

- (a) for low-head power plants:
 - (1) $d_{\text{limit.}} = 0.2 \text{ to } 0.5 \text{ mm}$
- (b) for medium and high-head power plants:
 - (2) $d_{\text{limit.}} < 0.1 \text{ to } 0.2 \text{ mm}$
- (c) for 100 m head and more:
 - (3) $d_{\text{limit.}} \approx 0.01 - 0.05 \text{ mm.}$

If the particles to be deposited consist of quartz sands, the lower limiting values apply. The values given under (c) can also be fixed for economic reasons when the particle fractions consist of particularly hard minerals (quartz, feldspar, garnet, etc.).

According to Keller [10], small hydroelectric power plants can be referred to as high-head power plants according to the following rule of thumb:

$$\text{high - head power plant: } \frac{h}{\sqrt[3]{Q}} \geq 100$$

where Q = design discharge in m^3/s , h = total head in m.

The pipelines for the water for power generation of such plants are usually very long (at relatively small discharge cross-sections), i.e. they are pipelines under high internal pressure.

Low-head power plants have heads $h \approx 10 \text{ m}$.

All plants between high-head and low-head power plants are therefore medium-head power plants.

If the above-mentioned grain-size limits are considered for different types of plant and if it is assumed that small hydroelectric power plants usually have heads ≤ 100 m, it can be concluded that the limiting particle diameter to be separated

- can in the normal case be fixed at 0.2 mm,
- should only in exceptional cases be selected with $d_{\text{limit}} = 0.05$ mm.

(Exceptions:

- head ≥ 100 m,
- mineral: pure quartz or similar,
- turbine type: Francis/cross-flow turbine).

5.2.4 Determination of the sand trap dimensions

Owing to an extension of the cross-section, the water flowing into the sand trap is so slowed down that the suspended matter particles can no longer be maintained in suspension and sink (cf. section 5.1).

The water particles entering and the suspended matter particles transported by them horizontally at an even velocity must reach the end of the basin only when the sinking process is completed, i.e. the sinking time t_s must be shorter than the time of passage (translation time) t_d through the basin (Fig. 45).

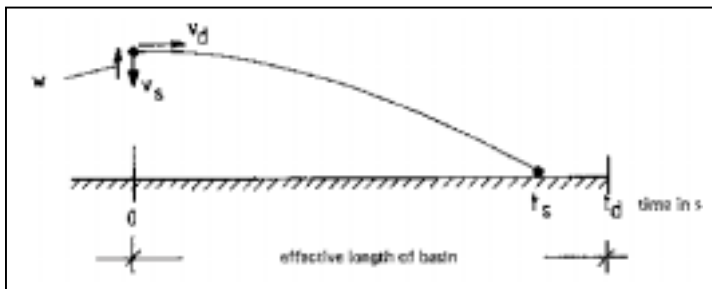

Fig. 45: Longitudinal section of sand trap. Schematic path curve of a settling sand particle "K" under the influence of turbulence. v_d flow velocity in the basin, v_s sinking velocity in stagnant water, w dynamic buoyancy due to turbulent flow; condition: $t_d > t_s$

The actual sinking velocity of the particles is then

$$v_s' = v_s - w \text{ (in m/s)}$$

where w is essentially a function of the mean flow velocity in the basin. With the estimated value

$$w = a v_d \text{ with } a = 0.04 \text{ [11].}$$

$$v_s' = v_s - 0.04 v_d \text{ (in m/s).}$$

For the settling process (Fig. 45) the following relationships result:

$$1 \quad t_d = \frac{L}{v_d} \text{ (in s),}$$

with L = effective basin length in m, v_d = mean flow velocity in m/s, and

$$2 \ t_s = \frac{h}{v_s'} \text{ (in s),}$$

with h = effective sand trap depth in m, v_s' = mean sinking velocity.

A rectangular cross-section of the sand trap results in the following relationship:

$$3 \ v_d = Q/(B h) \text{ (in m/s),}$$

with Q = discharge in m³/s, B = basin width in m, h = sand trap depth in m. By transformation and using the limiting relationship $t_d = t_s$, we have

$$4 \ L = \frac{v_d \cdot h}{v_s'} = \frac{v_d \cdot h}{v_s - 0.04 \cdot v_d} \text{ (in m).}$$

As can be seen, the denominator can assume a negative value. If this is the case, settling is not possible under the conditions assumed. It follows that the determination of the sinking velocity v_s is of the utmost importance. According to Popel [12], v_s is a function of the water movement, the state of flow in the water, the kinematic viscosity, the shape and size of the suspended matter, and of the specific weight of the particles.

The sinking velocity heavily depends upon the state of flow around the particle during sinking, and therefore also on the Reynolds' number.

The following is valid:

$Re < 1$ Stokes' law (laminar flow)

$$v_s = (s - 1) \cdot \frac{g}{18 \cdot \nu} d^2$$

with d = particle diameter, s = density of particles due to density of water (2.6 to 2.7 for sand), ν = kinematic viscosity of water (0.0132 cm²/s at 10°C in clean water), g = acceleration due to gravity = 9.81 cm/s².

$Re > 2000$ Newton's law

$$v_s = \sqrt{(s - 1) \cdot \frac{4 \cdot g \cdot d}{3 \cdot c}}$$

with c = coefficient of resistance of the particles (0.5 for round particles).

$1 < Re < 2000$

range of transition according to Rubey.

Fig. 1 in Annex 11 shows the sinking velocity v_s according to the relationships above. In the sand trap itself the flow is turbulent, with a Reynolds' number of

$$R_e = \frac{v_d \cdot D}{\nu} > 2000$$

with D = equivalent diameter ($4 F/U = 4 (B h)/(B + 2h)$), B = basin width, h = sand trap height (effective), F = cross-sectional area (cross-section of sand trap), U = wetted perimeter.

Therefore the sinking velocity v_s (according to Fig. 1 in Annex 11) must be reduced accordingly and introduced into formula 4. The flow velocity v_d must not exceed an upper value in order

- to allow the suspended matter to sink,
- to prevent suspended matter which has already settled being washed away,
- to prevent sinking suspended matter being brought into suspension again.

This velocity, which is to be considered the limiting value, can be treated as being equivalent to the "critical velocity" known from the bed load theories. According to Camp [13], this critical velocity is

$$v_d = a\sqrt{d} \quad (\text{in cm/s})$$

with d = particle diameter, a = coefficient as a function of d , $a = 36$ at $d > 1$ mm, $a=44$ at $1 \text{ mm} > d > 0.1$ mm, $a = 51$ at $d < 0.1$ mm.

For $d = 0.2$ the following results:

$$v_d = 44 \cdot \sqrt{0.2} = 19.7 \text{ cm / s.}$$

In practice, a mean flow velocity of

$$v_d = 0.2 \text{ m/s}$$

has proved effective.

By transformation of 1

$$v_d = L / t_d$$

and introduction into 3, the following relationship is obtained:

$$5 v_d = \frac{L}{t_d} = \frac{Q}{B \cdot h}$$

$$\rightarrow Q_{td} = L \times B \times h$$

i.e. the volume of the sand trap must be equal to the amount of water flowing in in the unit of time of the residence time (time of passage or sinking).

When the flow velocity v_d is known, the dimensions of the basin can be determined. As the length and width construction elements of the sand trap are less costintensive than the depth (foundation, soil excavation, etc.), the depth h is selected.

For small hydroelectric power plants, h should be between 0.5 and 2 m.

When h , v_s and v_d have been inserted in 4, L can be determined.

With V_d , h and Q , B can be determined from 5.

Appendix

Annex 1: Hydrometric and hydrometeorological measuring instruments

The measuring instruments listed in this Annex are selected instruments for the measurement of precipitation and flow velocities. The selection of the makes is limited to German manufacturers:

(1) Wilhelm Lambrecht GmbH
Friedlander Weg 65/67
D-3400 Gottingen
Tel. 0551/49 580

(2) Adolf Thies GmbH + Co. KG
Postfach 3536
D-3400 Gottingen
Tel. 0551/79 20 52

(3) A. Ott GmbH
Postfach 2120
D-8960 Kempten
Tel. 0831/20 59-0
Telex 54 723

(4) SEBA Hydrometrie GmbH
Postfach
D-8950 Kaufbeuren 2
Tel. 08341/62 026
Telex SEBA 54 624

The prices indicated are as per October 1985 and include value-added tax and in some cases (depending upon the manufacturer) packing and transport insurance. All companies deliver their instruments free place of destination in the Federal Republic of Germany.

1. Precipitation measuring instruments

1.1 Rain gauge according to Hellmann

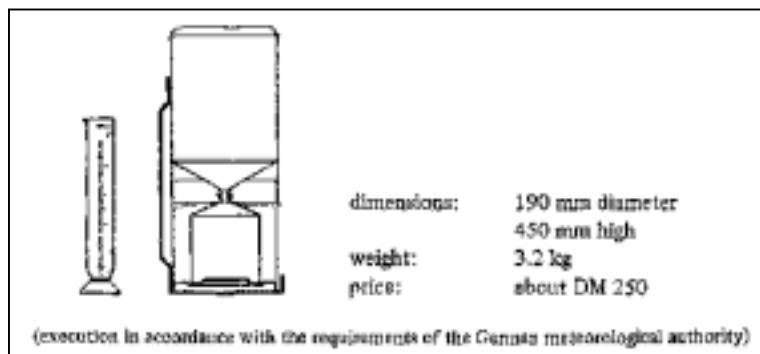

1.2 Rain recorder according to Hellmann (float principle)

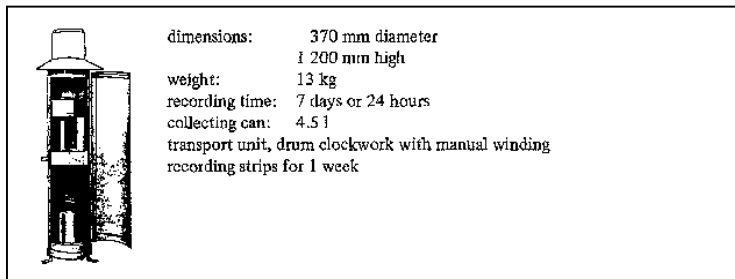

1.3 Rain recorder according to Hellmann (float principle)

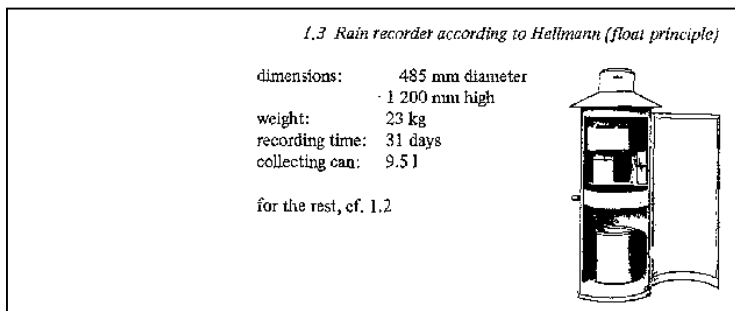

1.4 Rain recorder with tipping bucket

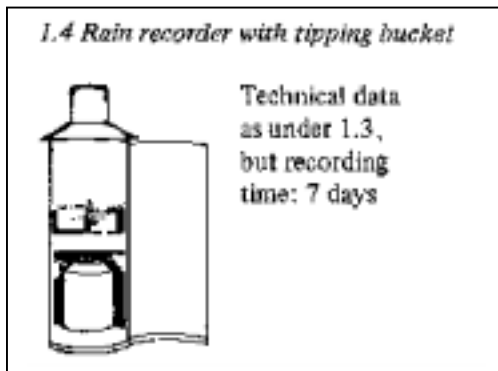

1.5 Prices

According to the manufacturer, the prices for rain recorders (float principle) are:

- without heater between about DM 1800 and DM 2850,
- with heater between about DM 2500 and DM 3450.

The price for a rain recorder with tipping bucket is about DM 3900.

2. Water-level gauges and accessories

2.1 Horizontal gauge/recording gauge

(drum-type recorder for the continuous recording of the water levels; protective shell necessary; low construction and maintenance requirements)

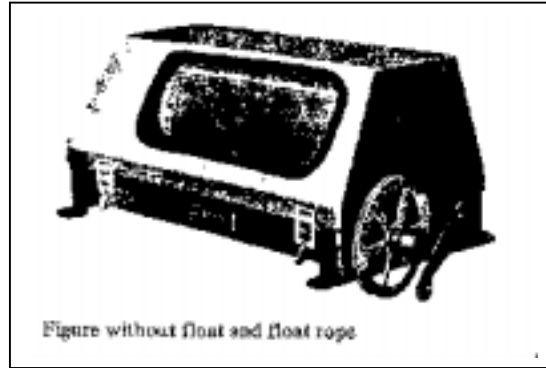
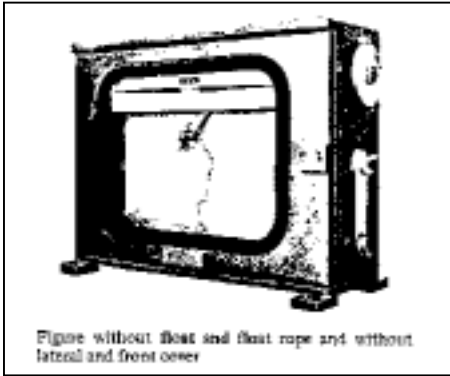

time of rotation of drum: 1 to 32 days
 drum drive: mechanical or electrical
 reversing indication (to cover extraordinary flood peaks): available
 measuring ranges: unlimited
 net weight (basic unit): 7 to 12 kg
 Accessories:

- clockwork,
- toothed wheels,
- float,
- reversing indication,
- counterweights,
- float rope.

Whether the accessories belong to the scope of supply depends upon the manufacturer, or the gauge is delivered according to customer's data.

The price for the complete gauge varies between about DM 2 400 and DM 3 200.

2.2 Band recording gauge/horizontal gauge

(as under 2.1 but installation in the open air possible); assembly on float tube with a diameter of 4 to 6".

Technical data as under 2.1 but

- design: band recorder or drum recorder
- casing: plastics, cast material or cast aluminium
- weight: plastics: about 12 to 16 kg, cast material: about 28 kg

According to the manufacturer, the price for a basic unit (complete with accessories but without float tube) is about DM 3500 to DM 5700.

2.3 Staff gauge

- material: cast aluminium or sheet steel
- staff of cast aluminium, very resistant
- fixing to solid, vertical objects or walls possible
- dimensions: 200 to 1000 mm
- weight: sheet steel 2.0 kg/m, cast aluminium 6.2 kg/m.

According to the construction (sheet steel or cast aluminium) and the manufacturer, the price for a staff gauge is about DM 200 to DM 550.

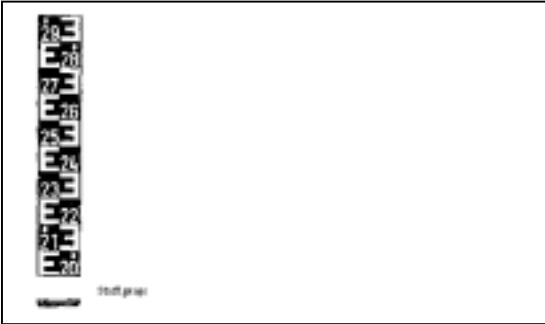

2.4 Construction of limit value gauges

Easy construction of a limit value gauge which always indicates the highest water level after the passage of the flood waves; construction of the gauge by fixing small tins, etc., at definite intervals to a staff.

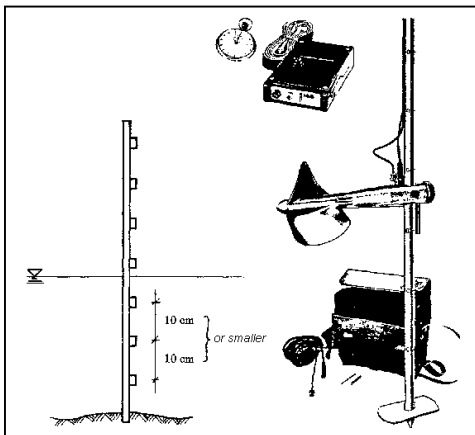

3. Current meter equipment for the measurement of the flow velocities

3.1 Compact current meter equipment

The compact current meter equipment can be used for measuring purposes at water depths of up to about 1.50 m. Adjustment of the measuring height (= current meter height) is made by displacing the current meter of the staff.

The scope of supply comprises:

- current meter,
- blade of plastics,
- counter with stop watch,
- connecting cable, 4 m long,
- bar, f 20 mm, 2 m long, two-part,
- extension bar, 1 m,
- pocket for the complete meter. The price is about DM 2800.

Universal current meter equipment

The universal current meter can be assembled individually. The complete scope of supply can consist, for example, of the following items (prices acc. to manufacturer):

- universal current meter with blade of plastics, between DM 2300 and DM 2650 - bar, 3 m, between DM 550 and DM 650
- connecting cable, 4 m, between DM 100 and DM 160
- canvas bag for the bars, between DM 120 and DM 160
- adjusting device for bar with intermediate piece (necessary for the rapid displacement of the blade on the bar), between DM 700 and DM 900
- counter (electromechanical), between DM 350 and DM 550
- stop watch, between DM 140 and DM 170
- instrument box, between DM 450 and DM 650.

The sum of these items is between about DM 4700 and DM 5900.

3.2 Float equipment

(without current meter; cf. prices under 3.1) The costs of a set of float equipment depend upon the amount of the loading weights (5 to 100 kg). As an example, a loading weight of 25 kg for a measuring range of $v=0.025$ to 3 m/s was used.

- Intermediate piece to the current meter, float helm and middle piece 25 kg in transport box, between about DM 4200 and DM 5150.
- Complete equipment incl. current meter, float, simple winch (cf. 3.3), carrying rope, counter, cable, etc., between about DM 13000 and DM 16000.

3.3 Winches and accessories

- Simple winches

(vertical displacement of the current meter from bridge)

Weight: 25 kg or 50 kg, depending upon manufacturer (depth counter, 25 m measuring cable, safety crank according to DIN, manual drive)

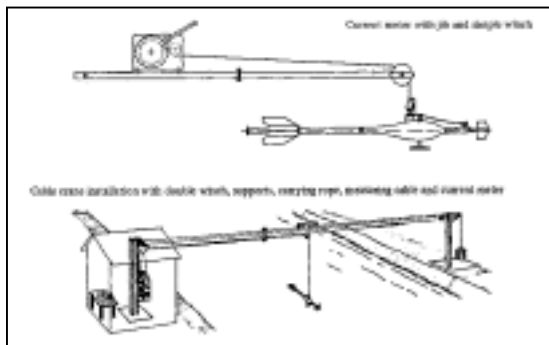

- Double winches

(vertical and horizontal displacement of the current meter for cable crane installation)

Double winches are necessary only in connection with a complete cable crane installation. The manufacturers supply these installations complete (winches, carrying cables, supports, current meter with float) according to the stated specific conditions of the respective river cross-section.

The price for

- simple winches is about DM 4000 to DM 4200,
- accessories (jib with return pulley) about DM 600 to DM 750.

Price example for a complete cable crane installation with a span of 50 m and float weights of 25 kg; scope of supply: current meter, carrying ropes and measuring cables, carrying rope attachments, return pulleys, crab, displacement ropes, double winch, tubular steel supports, counter according to manufacturer and equipment (without. assembly) between about DM 30000 and DM 37000.

Annex 2: Flood probability calculation according to the recommendations of the DVWK (1979)

Inclination coefficient C_{SX} / C_{SY}	Recurrence interval T in years													
	1,01	2	2,5	3	5	10	20	25	40	50	100	200	500	1000
0	- 2,326	0,000	0,253	0,440	0,842	1,282	1,645	1,751	1,960	2,054	2,326	2,576	2,878	3,090
0,1	- 2,252	- 0,017	0,238	0,417	0,836	1,292	1,673	1,785	2,007	2,107	2,400	2,670	3,004	3,233
0,2	- 2,178	- 0,033	0,222	0,403	0,830	1,301	1,700	1,818	2,053	2,159	2,473	2,763	3,118	3,377
0,3	- 2,104	- 0,050	0,205	0,388	0,824	1,309	1,726	1,849	2,098	2,211	2,544	2,856	3,244	3,521
0,4	- 2,029	- 0,066	0,189	0,373	0,816	1,317	1,750	1,830	2,142	2,261	2,615	2,949	3,366	3,666
0,5	- 1,955	- 0,083	0,173	0,358	0,808	1,323	1,774	1,910	2,185	2,311	2,686	3,041	3,488	3,811
0,6	- 1,880	- 0,099	0,156	0,342	0,800	1,328	1,797	1,939	2,227	2,359	2,755	3,132	3,609	3,956
0,7	- 1,806	- 0,116	0,139	0,327	0,790	1,333	1,819	1,967	2,268	2,407	2,824	3,223	3,730	4,100
0,8	- 1,733	- 0,132	0,122	0,310	0,780	1,336	1,839	1,993	2,308	2,453	2,891	3,312	3,850	4,244
0,9	- 1,660	- 0,148	0,105	0,294	0,769	1,339	1,859	2,018	2,346	2,498	2,957	3,401	3,969	4,388
1,0	- 1,588	- 0,164	0,088	0,277	0,758	1,340	1,877	2,043	2,384	2,542	3,022	3,489	4,088	4,531
1,1	- 1,518	- 0,180	0,070	0,270	0,745	1,341	1,894	2,066	2,420	2,585	3,087	3,575	4,206	4,673
1,2	- 1,449	- 0,195	0,053	0,242	0,732	1,340	1,910	2,087	2,455	2,626	3,149	3,661	4,323	4,815
1,3	- 1,383	- 0,210	0,036	0,225	0,719	1,339	1,925	2,108	2,489	2,666	3,122	3,745	4,438	4,955
1,4	- 1,318	- 0,225	0,018	0,207	0,705	1,337	1,938	2,128	2,521	2,706	3,271	3,828	4,553	5,095
1,5	- 1,256	- 0,240	0,001	0,189	0,690	1,333	1,951	2,146	2,552	2,743	3,330	3,910	4,667	5,234
1,6	- 1,197	- 0,254	- 0,016	0,171	0,675	1,329	1,962	2,163	2,582	2,780	3,388	3,990	4,779	5,371
1,7	- 1,140	- 0,268	- 0,033	0,153	0,660	1,324	1,972	2,179	2,611	2,815	3,444	4,069	4,890	5,507
1,8	- 1,087	- 0,282	- 0,050	0,135	0,643	1,318	1,981	2,193	2,638	2,848	3,499	4,147	5,000	5,642
1,9	- 1,037	- 0,294	- 0,067	0,117	0,627	1,310	1,989	2,207	2,664	2,881	3,553	4,223	5,108	5,775
2,0	- 1,990	- 0,307	- 0,084	0,099	0,609	1,302	1,996	2,219	2,689	2,912	3,605	4,298	5,215	5,908
2,1	- 0,946	- 0,319	- 0,100	0,081	0,592	1,293	2,001	2,230	2,172	2,942	3,656	4,372	5,320	6,039
2,2	- 0,905	- 0,330	- 0,116	0,063	0,574	1,284	2,006	2,240	2,735	2,970	3,705	4,444	5,424	6,168
2,3	- 0,867	- 0,341	- 0,131	0,045	0,555	1,273	2,009	2,248	2,755	2,997	3,753	4,515	5,527	6,296
2,4	- 0,832	- 0,351	- 0,147	0,027	0,537	1,262	2,011	2,256	2,775	3,023	3,800	4,584	5,628	6,423
2,5	- 0,799	- 0,360	- 0,161	0,010	0,518	1,250	2,012	2,262	2,793	3,048	3,845	4,652	5,728	6,548
2,6	- 0,769	- 0,369	- 0,176	- 0,007	0,499	1,238	2,013	2,267	2,811	3,071	3,889	4,718	5,827	6,672
2,7	- 0,740	- 0,377	- 0,189	- 0,024	0,480	1,224	2,012	2,272	2,827	3,093	3,832	4,783	5,923	6,794
2,8	- 0,714	- 0,384	- 0,203	- 0,041	0,460	1,210	2,010	2,275	2,841	3,114	3,973	4,847	6,019	6,915
2,9	- 0,690	- 0,390	- 0,215	- 0,057	0,440	1,195	2,007	2,277	2,855	3,134	4,013	4,909	6,113	7,034
3,0	- 0,667	- 0,396	- 0,227	- 0,073	0,420	1,180	2,003	2,278	2,867	3,152	4,051	4,970	6,205	7,152

Table 1: k values for the Pearson-3, log-Pearson-3 and Gumbel distribution

Course of calculation

$x_1, x_2, \dots, x_i, \dots, x_N$

observation values

$$\text{arithmetic mean } \bar{x} = \frac{1}{N} \sum_{i=1}^N X_i \quad (1)$$

$$\text{standard deviation } S_x = \sqrt{\frac{1}{N-1} \sum_{i=1}^N (X_i - \bar{X})^2} \quad (2)$$

$$\text{variation coefficient } C_{vx} = \frac{S_x}{\bar{X}} \quad (3)$$

$$\text{inclination coefficient } C_{sx} = \frac{N \sum_{i=1}^N (X_i - \bar{X})^3}{(N-1)(N-2)S_x^2} \quad (4)$$

The distribution functions used are unilaterally limited. The limit of the feature range is

$$d = \bar{x} \left(1 - \frac{2 \cdot C_{vx}}{C_{sx}}\right) \quad (5)$$

If the calculation is to be carried out by hand with the aid of tables, it is recommended to use the proportion quantities $x_i = x_i / \bar{x}$ and $h_i = y_i / y$ in the place of the values x_i and y_i .

$$C_{vx} = \sqrt{\frac{1}{N-1} \sum (\xi_i - 1)^2} \quad (6)$$

$$S_x = C_{vx} \cdot \bar{X}$$

$$C_{sx} = \frac{N \cdot \sum (\xi_i - 1)^3}{(n-1)(N-2) \cdot C_{vx}^3} \quad (7)$$

The following calculation steps are to be carried out:

- (1) Calculate y_i by taking the logarithm of the observation values x_i .
- (2) Calculate \bar{y} , C_{vy} and C_{sy} from the y_i values.
- (3) If C_{sy} is greater than or equal to zero, calculate the sought T-yearly flood discharge x_T for the recurrence interval T:

$$y_T = \bar{y} + S_y (k(C_{sy}, T)) \quad \text{or (8)}$$

$$y_T = \bar{y} [(1 + c_{vy} \cdot k(C_{sy}, T))] \quad (9)$$

The k values according to Pearson are to be taken from Table 1 (linear interpolation).

$$x_T = 10^{y_T} \text{ if decadic logarithms are used}$$

and

$x_T = e^{yT}$ if natural logarithms are used.

Here the course of calculation is terminated.

Year	HQ [m ³ /s]	Rank No. m	HQ [m ³ /s]	N +	y	n = y / y	n - 1		(n - 1) ²	(n - 1) ³	
							-	+		-	+
1951	80.60	1	516.00	35.00	2.71	1.2387		0.2400	0.0576		0.0118
1952	164.00	2	296.00	17.50	2.47	1.1284		0.1300	0.0169		0.0011
1953	136.00	3	279.00	11.67	2.45	1.1167		0.1200	0.0144		0.0010
1954	82.50	4	274.00	8.75	2.44	1.1131		0.1100	0.0121		0.0010
1955	176.00	5	261.00	7.00	2.42	1.1035		0.1000	0.0100		0.0009
1956	203.00	6	242.00	5.83	2.38	1.0885		0.0900	0.0081		0.0007
1957	179.00	7	234.00	5.00	2.37	1.0818		0.0800	0.0064		0.0005
1958	136.00	8	210.00	4.38	2.32	1.0604		0.0600	0.0036		0.0002
1959	110.00	9	203.00	3.89	2.31	1.0537		0.0500	0.0025		0.0001
1960	160.00	10	190.00	3.50	2.28	1.0405		0.0400	0.0016		0.0000
1961	242.00	11	186.00	3.18	2.27	1.0363		0.0400	0.0016		0.0000
1962	234.00	12	179.00	2.19	2.25	1.0286		0.0300	0.0009		0.0000
1963	179.00	13	179.00	2.69	2.25	1.0287		0.0300	0.0009		0.0000
1964	152.00	14	176.00	2.50	2.25	1.0253		0.0300	0.0009		0.0000
1965	190.00	15	175.00	2.33	2.24	1.0242		0.0200	0.0004		0.0000
1966	279.00	16	164.00	2.19	2.21	1.0113		0.0100	0.0000		0.0000
1967	129.00	17	161.00	2.06	2.21	1.0077		0.0100	0.0010		0.0000
1968	261.00	18	160.00	1.94	2.20	1.0064		0.0100	0.0000		0.0000
1969	122.00	19	152.00	1.84	2.18	0.9963	(0.0037		0.0000	(0.0000	
1970	274.00	20	149.00	1.75	2.17	0.9923	(0.0077		0.0001	(0.0000	
1971	79.30	21	145.00	1.67	2.16	0.9869	(0.0131		0.0002	(0.0000	
1972	68.70	22	136.00	1.59	2.13	0.9742	(0.0258		0.0007	(0.0000	
1973	66.70	23	136.00	1.52	2.13	0.9742	(0.0258		0.0007	(0.0000	
1974	161.00	24	129.00	1.46	2.11	0.9637	(0.0363		0.0013	(0.0000	
1975	175.00	25	123.00	1.14	2.09	0.9543	(0.0457		0.0021	(0.0000	
1976	94.30	26	122.00	1.35	2.09	0.9527	(0.0473		0.0022	(0.0000	
1977	123.00	27	110.00	1.30	2.04	0.9321	(0.0679		0.0046	(0.0000	
1978	87.30	28	94.30	1.25	1.97	0.9016	(0.0984		0.0097	(0.0000	
1979	186.00	29	87.30	1.21	1.94	0.8863	(0.1137		0.0129	(0.0014	
1980	210.00	30	82.50	1.17	1.92	0.8751	(0.1249		0.0156	(0.0019	
1981	296.00	31	80.60	1.13	1.91	0.8705	(0.1295		0.0168	(0.0021	
1982	145.00	32	79.30	1.09	1.90	0.8672	(0.1328		0.0176	(0.0023	
1983	149.00	33	68.70	1.06	1.84	0.8388	(0.1612		0.0260	(0.0041	
1984	516.00	34	66.70	1.03	1.82	0.8329	(0.1671		0.0279	(0.0046	
							(1.2009	1.2000	0.2763	(0.0183	0.0177
											(0.0006

Table 2: Calculation of the 10, 50, 100, 200 and 1000 - yearly flood discharge for an observation series of 34 years acc. to the DVWK recommendation in tabulated form (example gauge Betzdorf / Federal Republic of Germany). y decadic logarithms of observation values, N extent of data set, HQ max. annual discharges in m³/s, period of observation: 34 years.

- (4) If C_{Sy} is smaller than zero, calculate x , C_{Vx} , C_{Sx} and d from the x_i values.
- (5) If C_{Sx} or d is smaller than zero, put $c_{Sx} = + 2 C_{Vx}$ and continue with step 7.
- (6) If C_{Sx} and d are greater than or equal to zero, continue with step 7.

Steps 1 and 2 cf. Table 2

Parameters:	arithmetic mean $y = 2.19$
	variation coefficient $C_{Vy} = 0.0915$
	inclination coefficient $C_{Sy} = - 0.0252$

YEAR	HQ[m ³ /s]	Rank No.	HQ[m ³ /s]	N + 1/m	$\xi = x / x$	$\xi - 1$		$(\xi - 1)^2$	$(\xi - 1)^3$	
1951	80.60	1	516.00	35.00	3.00		2.00	4.0000		8.0000
1952	164.00	2	296.00	17.50	1.72		0.72	0.5184		0.3732
1953	136.00	3	279.00	11.67	1.62		0.62	0.3844		0.2383
1954	82.50	4	270.00	8.75	1.59		0.59	0.3481		0.2054
1955	176.00	5	261.00	7.00	1.52		0.52	0.2704		0.1406
1956	203.00	6	242.00	5.83	1.41		0.41	0.1681		0.0689
1957	179.00	7	234.00	5.00	1.36		0.36	0.1296		0.0467
1958	136.00	8	210.00	4.38	1.22		0.22	0.0484		0.0106
1959	110.00	9	203.00	3.89	1.18		0.18	0.0324		0.0058
1960	160.00	10	190.00	3.50	1.10		0.10	0.0100		0.0010
1961	242.00	11	186.00	3.18	1.08		0.08	0.0064		0.0005
1962	234.00	12	179.00	2.92	1.04		0.04	0.0016		0.0001
1963	179.00	13	179.00	2.69	1.04		0.04	0.0016		0.0001
1964	152.00	14	176.00	2.50	1.02		0.02	0.0004		0.0000
1965	190.00	15	175.00	2.33	1.02		0.02	0.0004		0.0000
1966	279.00	16	164.00	2.19	0.95	0.05		0.0025	0.0001	
1967	129.00	17	161.00	2.06	0.94	0.06		0.0036	0.0002	
1968	261.00	18	160.00	1.94	0.93	0.07		0.0049	0.0003	
1969	122.00	19	152.00	1.84	0.88	0.12		0.0144	0.0017	
1970	274.00	20	149.00	1.75	0.87	0.13		0.0169	0.0022	
1971	79.30	21	145.00	1.67	0.84	0.16		0.0256	0.0041	
1972	68.70	22	136.00	1.59	0.79	0.21		0.0441	0.0093	
1973	66.70	23	136.00	1.52	0.79	0.21		0.0441	0.0093	
1974	161.00	24	129.00	1.46	0.75	0.25		0.0625	0.0156	
1975	175.00	25	123.00	1.40	0.72	0.28		0.0784	0.0220	
1976	94.30	26	122.00	1.35	0.71	0.29		0.0841	0.0244	
1977	123.00	27	110.00	1.30	0.64	0.36		0.1296	0.0467	
1978	87.30	28	94.30	1.25	0.55	0.45		0.2025	0.0911	
1979	186.00	29	87.30	1.21	0.51	0.49		0.2401	0.1176	
1980	210.00	30	82.50	1.17	0.48	0.52		0.2704	0.1406	
1981	296.00	31	80.60	1.13	0.47	0.53		0.2709	0.1489	
1982	145.00	32	79.30	1.09	0.46	0.54		0.2916	0.1575	
1983	149.00	33	68.70	1.06	0.40	0.60		0.3600	0.2160	
1984	516.00	34	66.70	1.03	0.39	0.61		0.3721	0.2270	
						5.93	5.92	8.4485	1.2346	9.0913
										7.8567

Table 3

As $C_{sy} < 0$, step 3 follows: cf. Table 3

(7) Calculate the sought T-yearly flood discharge x_T for the recurrence interval T:

$$x_T = x + s_x \cdot k_3(C_{sx}, T) \text{ or (10)}$$

$$x_T = x [1 + C_{vx} k(C_{sx}, T)] \text{ (11)}$$

The k values according to Pearson are to be taken from Table 1 (linear interpolation). Here the course of calculation is terminated.

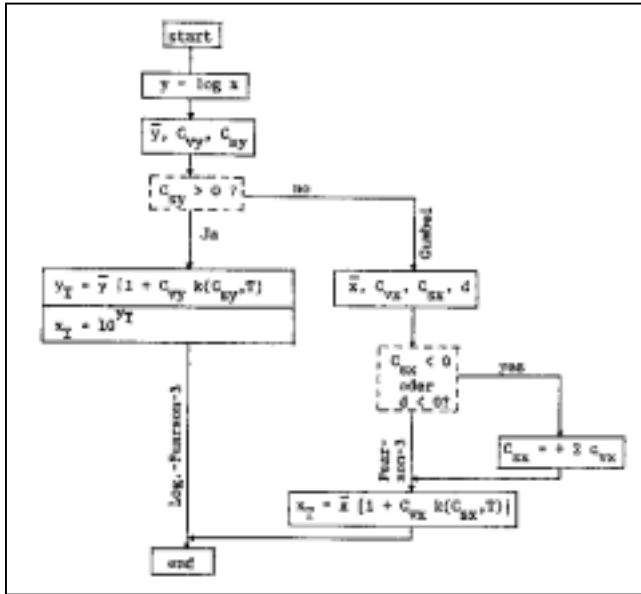

Fig.1: Flow chart

The flow chart (Fig. 1) shows once again the course of calculation.

Parameters: arithmetic mean $x = 171.95 \text{ m}^3/\text{s}$ variation coefficient $Cvx = 0.5059$ standard deviation $sx = 87.0$ inclination coefficient $Csx = 0.306$

With $k(Cx, T)$ from the k value table (for the Pearson-3, the log-Pearson-3 and the Gumbel distribution), the desired HQ value determination is carried out. For the present example, the HQ values are the following:

	HQ 10	HQ 50	HQ 100	HQ 200	HQ 1000
	(m^3/s)	(m^3/s)	(m^3/s)	(m^3/s)	(m^3/s)
Pearson III	284.1	423.2	484.4	546.5	694.1

For the graphical representation, cf. Fig. 2.

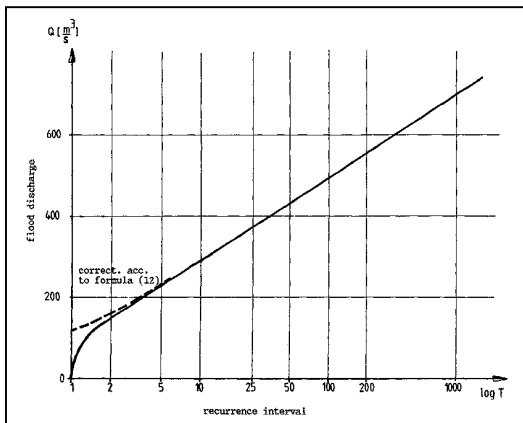

Fig. 2: Flood probability

When flood discharges with short recurrence periods ($T < 15$ years) are determined on the basis of annual series, in the case of the determination of the T -yearly flood according to the formula $x_T = . . .$ or $y_T = . . .$, a correction of the recurrence interval must be made, for which the k values are determined. This is to be attributed to the use of annual series, whereas we are interested in the recurrence intervals between two floods of a definite extent irrespective of whether maximum annual discharges are concerned. The correction is made according to the formula

$$T = (e^{1/T^*}) / (e^{1/T} - 1) \quad (12)$$

where T^* is the sought actual recurrence period (Draschoff, 1972).

Owing to the data series which statistically are normally very short, the extrapolation to long recurrence periods should not be exaggerated. But practical requirements make it often necessary to calculate discharges of a specified (generally long) recurrence period from a small amount of data. In this case, one should be aware of the great uncertainty of the results. Confidence intervals around the distribution functions offer the possibility of making plain this uncertainty as a function of the length of the observation series, the recurrence interval and an error probability.

Partial series which are taken from an observation period of M years contain N values, N being generally greater than M . The course of calculation of the recommendation can be followed. It is, however, to be borne in mind that the equations $x_T = . . .$ or $y_T = . . .$ and, thus, the tables of the k values are to be entered into computationally with a recurrence interval T other than the sought recurrence period T^* :

$$T = (N / M) \times T^* \quad (13)$$

The sought 20-yearly flood, for example, is calculated from a partial series with 52 values from 21 years of observation according to the Pearson-3 distribution:

$$T = (52 / 21) \times 20 = 50 \text{ years with } x [1 + C_{VX} k \cdot (C_{SC}; T = 50)]$$

Annex 3: Calculation example for a free overfall over a wooden beam weir

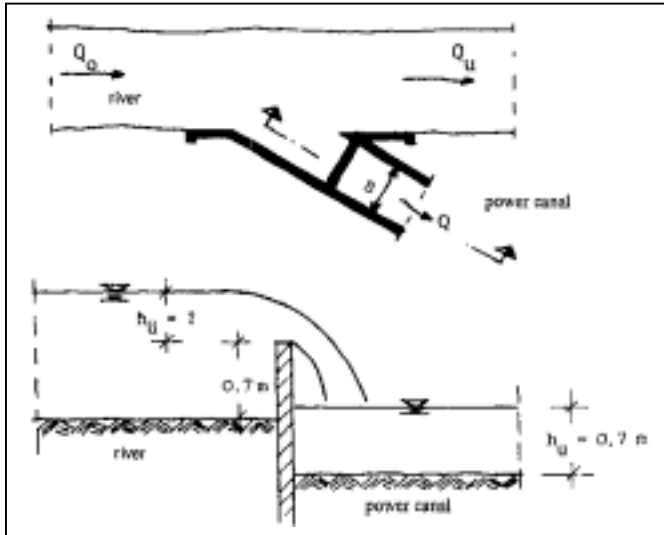

Fig. 1: Free overfall over a wooden beam weir (numerical example)

weir form	μ
beak: sharp edges	0.48-0.51
beak: round edges	0.53-0.55
round overfall	0.70
sharp-edged	0.64
rounded	0.75
well-shaped	0.79

Fig. 2: Weir coefficient μ for various weir forms (according to Press/Schroder [31])

Over a wooden beam weir an amount of water for power generation of at least 0.65 m³/s is to be evacuated. The water level in the power canal and in the river can be seen in Fig. 1. The weir has a width of 2 m. The necessary weir head $h_{\bar{u}}$ is sought. After transformation of the weir formula

$$Q = \frac{2}{3} \cdot c \cdot \mu \cdot B \cdot \sqrt{2g} \cdot h^{3/2}$$

the weir head h results for the free overfall with $c = 1$:

$$h_{\bar{u}} = \left(\frac{3}{2} \cdot \frac{Q}{\mu \cdot B \cdot \sqrt{2g}} \right)^{2/3} \text{ (m)}$$

with $\mu = 0.64$ (sharp-crested weir, cf. Fig. 2), $B = 2.0$ m, $g = 9.81$ m/s² (acceleration due to gravity), $Q = 0.65$ m³/s, $c =$ correction factor. The following results:

$$h_{\bar{u}} = \left(\frac{3}{2} \cdot \frac{0.65}{0.64 \cdot 2 \cdot \sqrt{2 \cdot 9.81}} \right)^{2/3} = 0.31 \text{ m}$$

This means that the discharge capacity of the wooden beam weir is about 0.65 m³/s in the example of a weir head of 0.31 m. If this minimum amount of water for power generation is to be evacuated in the power canal, the crest height of the weir must be 0.31 m below the lowest water level of the river!

Annex 4: Calculation example for a submerged overfall over a wooden beam weir

Owing to a flood event, the water level of the river has risen, and simultaneously considerably greater amounts of water flow into the power canal so that its water level has risen as well. This maximum water level results from the hydraulics of the canal and can be determined for each amount of water to be evacuated. For this numerical example the corresponding values have been entered in Fig. 1. For this condition of the submerged overfall the amount of water is to be determined which is evacuated by the weir. The weir width is 2 m.

- Discharge capacity of the weir

$$Q = \frac{2}{3} \cdot c \cdot \mu \cdot B \cdot \sqrt{2g} \cdot h_{\bar{u}}^{3/2} \text{ (m}^3\text{/s)}$$

with $h_{\bar{u}}$ = weir head (m), g = acceleration due to gravity = 9.81 m/s², B = weir width (m), μ = weir coefficient (-) (cf. Annex 3), c = correction coefficient.

- Correction factor c

$$h' = 0.30 \text{ m,}$$

$$h_{\bar{u}} = 0.80 \text{ m,}$$

$$h' / h_{\bar{u}} = 0.30 / 0.80 = 0.375$$

From the diagram, it thus follows for c (wooden beam weir): $c \sim 0.86$.

- Discharge capacity of the weir

$$Q = \frac{2}{3} \cdot c \cdot \mu \cdot B \cdot \sqrt{2g} \cdot h_{\bar{u}}^{3/2} \text{ (m}^3\text{/s)} = \frac{2}{3} \cdot 0.86 \cdot 0.64 \cdot 2 \cdot \sqrt{2 \cdot 9.81} \cdot 0.8^{3/2} = 2.3 \text{ m}^3 / \text{s}$$

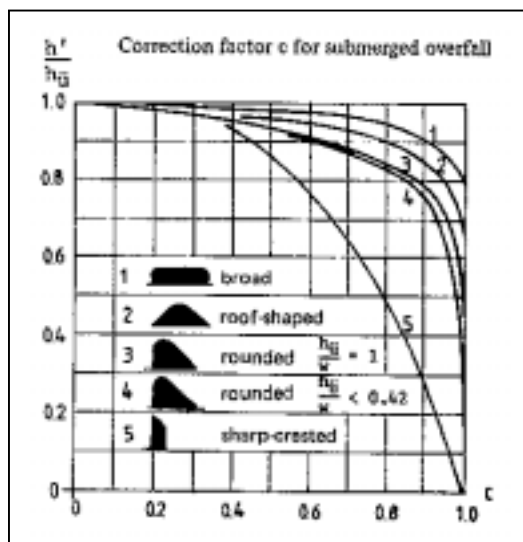

Correction factor c for submerged overfall

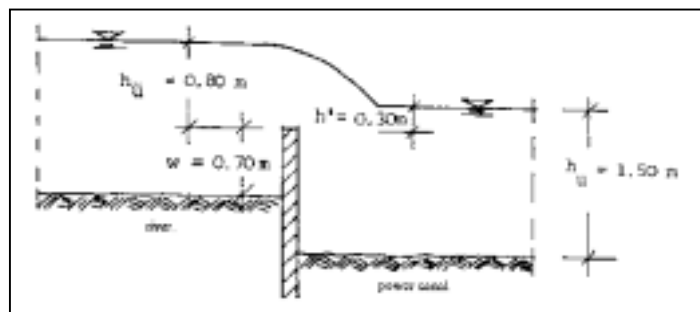

Fig. 1: Submerged overfall over a wooden beam weir (numerical example)

Annex 5: Calculation example for a discharge over a weir with race door or stilling basin

The design of such an arrangement requires the following steps:

(1) The headwater depth h_0 and the tail water depth h_u are given quantities. The headwater depth results from the water level of the river and the tail water depth is dependent upon the hydraulic conditions downstream, i.e. upon the evacuation of the amounts of water flowing over the weir into a river course or into a power canal with the respective water level in the river and in the power canal.

(2) From the weir formula the value h and, thus, the height of the weir crest are determined.

(3) Subsequently, the dimensions and a hydraulically favourable form of the weir are selected.

(4) It is presupposed that the bottom of the race floor is at the level of the river bottom. Then the water level h_1 at the beginning of the race floor can be determined as follows:

$$h_1 = h + w - \frac{v_1^2}{2g} - \Delta Z_{el}$$

$$\text{with } h = h_u + \frac{v_0^2}{2g}$$

$$\text{with } \frac{v_1^2}{2g} = \frac{Q^2}{h_1^2 \cdot B^2 \cdot 2g}$$

where Q = discharge over the weir (m^3/s), B = weir width (m)

$$\Delta Z_{el} = \lambda \cdot \frac{v_1^2}{2g},$$

λ = loss coefficient, about 0.1

$$h_1 = h + w - \frac{Q^2}{h_1^2 \cdot B^2 \cdot 2g} - 0.1 \cdot \frac{Q^2}{h_1^2 \cdot B^2 \cdot 2g}$$

$$h_1 = h + w - \frac{Q^2}{h_1^2 \cdot B^2 \cdot 2g} \cdot 1.1(\text{m})$$

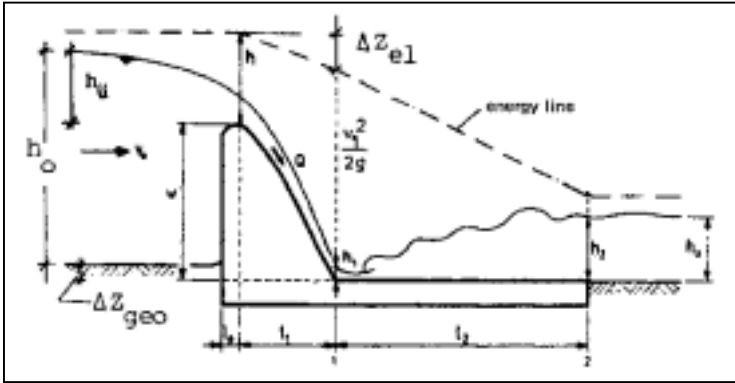

Fig. 1: Fixed weir (elevation of water level and energy line)

(5) The water depth h_2 corresponding to the water depth h_1 is determined with the following formula

$$h_2 = \frac{-h_1}{2} + \sqrt{\frac{h_1^2}{4} + \frac{2 \cdot Q^2}{g \cdot B^2 \cdot h_1}} \quad (\text{m})$$

g = acceleration due to gravity = 9.81 m/s^2

If h_2 just agrees with the tail water depth h_u , the assumption of the elevation of the stilling basin bottom is confirmed. (The tail water depth h_u results from the hydraulic conditions of the river or canal and can be roughly calculated with the formulas given in the relevant literature unless the water levels for definite discharges are known.) If the h_2 calculated in step 5 is smaller than the tail water depth, the nappe is dammed and the hydraulic jump drowned. The hydraulic jump is then shorter than calculated in step 6. Countermeasure: flatter design of the downstream face of the weir (cf. Fig. 2).



Fig. 2: Dammed hydraulic jump; Free hydraulic jump

In the two cases mentioned in step 5, now the stilling basin length can be determined with step 6.

If h^2 is greater than the tail water depth h_u , the hydraulic jump will be so shifted downstream that a longer race floor becomes necessary. This will mostly be the case if $F_1 > 4.0$ (cf. step 6).

Countermeasure: Construction of a stilling basin and arrangement of a countersill as described in step 7 (cf. Fig. 3).

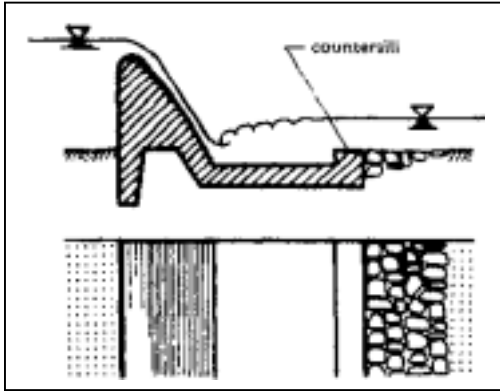

Fig. 3: Stilling basin with countersill

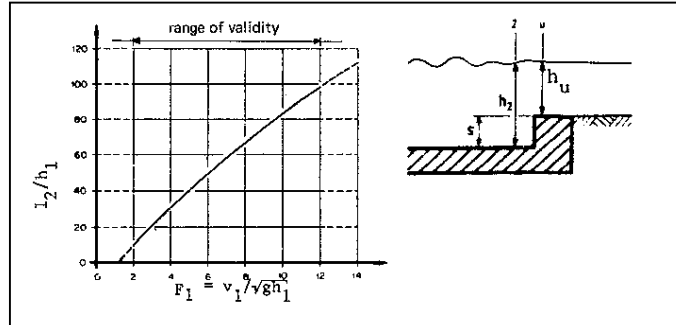

Fig. 4: Diagram for determining the hydraulic jump length l_2 for horizontal rectangular channels (source [3]); Fig. 5: Design values at the end of the stilling basin

(6) Determination of the stilling basin length: The stilling basin length can be taken from the diagram in Fig. 4. It is equal to the length of the hydraulic jump unless the latter is reduced by a sill as described in step 7. For the determination of the stilling basin length, Froude's number must be determined:

$$F_1 = \frac{v_1}{\sqrt{g \cdot h_1}}$$

$$\text{with } v_1 = \frac{Q}{B \cdot h_1} \text{ (m/s),}$$

where Q = discharge over the weir (m^3/s), B = weir width = stilling basin width (m), h_1 = water level at beginning of stilling basin (m). From the diagram the stilling basin length is obtained as a function of h_1 . (7) For the arrangement of the stilling basin bottom at a lower level, the measure s (cf. Fig. 5) is estimated as follows:

$$s > h_2 - h_u \text{ (in m)}$$

- determination of the new h_1 (now h_1 old + s) and h_2 according to steps 4 and 5
- determination of the stilling basin length with

$$L \sim 5 h_u + s \text{ (in m)}$$

Numerical example (cf. Figs. 6 and 7 below)

(1) Data given

- headwater level (maximum impounding head) in the river:

$$h_0 = \text{max. } 2.0 \text{ m}$$

- tail water level in the river at $Q = 10 \text{ m}^3/\text{s}$ (max. amount of flood water to be evacuated):

$$h_u = 0.70 \text{ m}$$

- weir width: $B = 9 \text{ m}$
- weir coefficient: $\mu = 0.60$ (broad-crested weir)

(2) Determination of the weir crest height w

- weir formula:

$$Q = \frac{2}{3} \cdot \mu \cdot B \cdot \sqrt{2g} \cdot h_u^{3/2}$$

Transformation with respect to h :

$$h_u = \left(\frac{3}{2} \cdot \frac{10}{0.6 \cdot 9 \cdot \sqrt{2 \cdot 9.81}} \right)^{2/3} \text{ (m)}$$

Introduction of the values:

$$h_u = \left(\frac{3}{2} \cdot \frac{10}{0.6 \cdot 9 \cdot \sqrt{2 \cdot 9.81}} \right)^{2/3} = 0.73 \text{ m}$$

The weir crest height is determined from the maximum elevation of the water level less the weir head:

$$w = h_0 - h_u = 2.0 - 0.73 = 1.27 \text{ m}$$

(3) Graphical representation of the dimensions

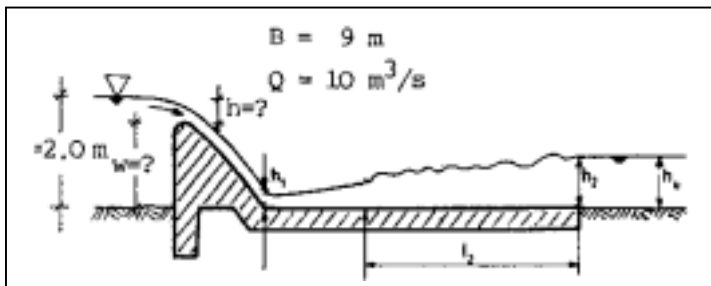

Fig. 6: Design of the stilling basin without sill or race floor (numerical example) (schematic representation of the weir)

(4) Determination of the elevation of the water surface h_1

$$h_1 = h + w - \frac{Q^2}{h_1^2 \cdot B^2 \cdot 2g} \cdot 1.1 \text{ (m)}$$

$$h_1 = 0.73 + 1.27 - \frac{10^2}{h_1^2 \cdot 9^2 \cdot 2 \cdot 9.81} \cdot 1.1$$

$$h_1 = 2.0 - 0.069 / h_1^2$$

$$h_1^3 - 2 \cdot h_1^2 + 0.069 = 0 \text{ (solve equation iteratively!)}$$

$$h_1 = 0.20 \text{ m}$$

(5) Determination of the conjugate water depth h_2

$$h_2 = -\frac{h_1}{2} + \sqrt{\frac{h_1^2}{4} + \frac{2 \cdot Q^2}{g \cdot B^2 \cdot h_1}}$$

$$h_2 = -\frac{0.20}{2} + \sqrt{\frac{0.2^2}{4} + \frac{2 \cdot 10^2}{9.81 \cdot 9^2 \cdot 0.2}} = 1.00 \text{ m}$$

$$h_2 = 1.00 \text{ m} > h_U = 0.70 \text{ m}$$

$$\Delta h = s = 1 - 0.70 \text{ m} = 0.30 \text{ m}$$

(6) Determination of the stilling basin length (without sill = length of race floor)

$$F_1 = \frac{v_1}{\sqrt{g \cdot h_1}} = \frac{Q}{B \cdot h_1 \cdot \sqrt{g \cdot h_1}} = \frac{10}{9 \cdot 0.2 \cdot \sqrt{9.81 \cdot 0.2}} \cong 4$$

from diagram in Fig. 36.

$$L_2 / h_1 = 30 \text{ @ } L_2 = 30 \cdot 0.2 = 6 \text{ m}$$

This means that the stilling basin length without sill would have to be 6 m.

(7) Arrangement of the stilling basin bottom at a lower level (shortening of the stilling basin) (with sill = stilling basin; reduced length of the structure)

Selected:

$$s = 0.50 \text{ m}, h_{U \text{ new}} = h_U + s = 0.70 + 0.50 = 1.20 \text{ m}$$

$$h_{1 \text{ new}} = h + w - \frac{Q^2}{h_1^2 \cdot B^2 \cdot 2g} \cdot 1.1$$

$$w_{\text{new}} = 1.27 + 0.50 = 1.77 \text{ m}$$

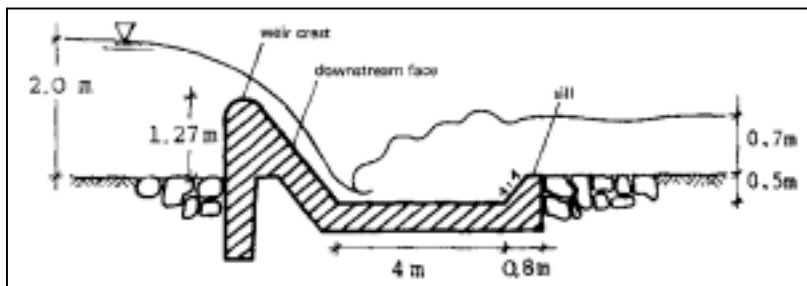

Fig. 7: Design of the stilling basin with sill (numerical example) (schematic representation of the weir)

$$h_1 \text{ new} = 0.73 + 1.77 - 10^2 / (h_1^2 \cdot 9.81) = 1.1$$

$$h_1 = 2.5 - 0.069 / h_1^2$$

$$h_1^3 - 2.5 \cdot h_1^2 + 0.069 = 0 \text{ (solve iteratively!)}$$

$$h_1 \text{ new} \sim 0.17 \text{ m}$$

$$h_2 \text{ new} = -\frac{0.17}{2} + \sqrt{\frac{0.17^2}{4} + \frac{2 \cdot 10^2}{9.81 \cdot 9^2 \cdot 0.17}} = 1.13 \text{ m}$$

$$h_2 \text{ new} = 1.13 \text{ m} < h_U \text{ new} = 1.20 \text{ m}$$

Stilling basin length

$$L \sim 5 \cdot h_U + s = 5 \cdot 0.7 + 0.5 = 4 \text{ m}$$

Annex 6: Calculation example for a straight side weir

I. With the aid of a side weir, an amount of water for power generation $Q_A = 0.4 \text{ m}^3/\text{s}$ is to be diverted from a river. In periods of low water, the river carries an amount of water of $Q_0 = 8 \text{ m}^3/\text{s}$.

The tail water level t_U for the residual amount of water of

$$Q_U = Q_0 - Q_A = 8 - 0.4 = 7.6 \text{ m}^3/\text{s}$$

is $t_U = 1.20 \text{ m}$ (quantity given by the rating curve = water level/discharge relation or determination with calculation methods given by the relevant literature).

The river width B is 6 m.

We seek the length of the side weir which should have a round crest.

First the minimum weir head h_U necessary in periods of low water is selected:

$$h_U = 0.20 \text{ m.}$$

The weir crest height thus is

$$w = t_U - h_U = 1.20 \text{ m} - 0.20 \text{ m} = 1.00 \text{ m.}$$

With the known values Q_0 , B_0 , w , h_{Eu} and t_U , h_0 is iteratively determined from the following formula:

$$(h_0 + w)^3 - h_{Eu} (h_0 + w)^2 + \alpha \cdot \frac{Q_0^2}{2g \cdot B_0^2} \cong 0$$

with:

$$h_{EU} = t_U + v_U^2 / 2g \text{ (m) (energy head)}$$

$$v_U = Q_U / (t_U \cdot B_U) = 7.6 / (1.2 \cdot 6.0) = 1.06 \text{ m/s}$$

$$h_{EU} = 1.20 + 1.03^2 / (2 \cdot 9.81) = 1.25 \text{ m}$$

When the values are introduced into the formula, and with $oe = 1.1$, the following results:

$$(h_0 + 1.00)^3 - 1.25(h_0 + 1.00)^2 + \frac{1.1 \cdot 8.0^2}{2 \cdot 9.81 \cdot 6.0^2} \cong 0$$

The iterative solution yields:

$$h_0 = 0.17 \text{ m. .}$$

Now the mean weir head is obtained:

$$h_m = (h_0 + h_U) / 2 = (0.17 + 0.20) / 2 = 0.19 \text{ m}$$

From the diagram n is read as a function of

$$h_m / (h_m + w) = 0.19 / (0.19 + 1.00) = 0.16$$

and $Q_U > 0$ value for n :

$$n \sim 1.05$$

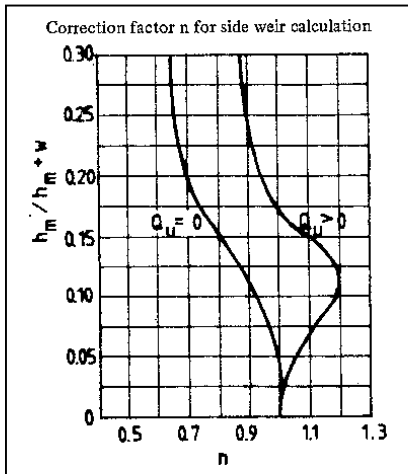

Correction factor n for side weir calculation

With this value the following is obtained:

$$\alpha = n \alpha = 1.05 \cdot 1.1 = 1.16.$$

Introduction of the value a into the above formula and seeking of h_0 by iterative solution:

$$(h_0 + w)^3 - h_{Eu} (h_0 + w)^2 + \frac{Q_0^2}{2g \cdot B_0^2} \cong 0$$

Introduction of the values into the formula:

$$(h_0 + 1.00)^3 - 1.25(h_0 + 1.00)^2 + 1.16 \frac{8^2}{2 \cdot 9.81 \cdot 6^2} \cong 0$$

The iterative solution is

$$h_0 = 0.17\text{m}$$

(Here the course of calculation is terminated as the 2nd value does not differ from the 1st value!)

- Mean weir head.

$$h_m = (h_0 + h_u) / 2 = (0.17 + 0.20) / 2 = 0.18 \text{ m}$$

- The side weir length required for the evacuation of the amount of water for power generation

$Q_A = 0.4 \text{ m}^3/\text{s}$ is obtained from the weir formula:

$$Q_A = \frac{2}{3} \cdot \mu^x \cdot L \cdot \sqrt{2g} \cdot h_m^{3/2} \text{ (m}^3/\text{s)}$$

- Transformation with respect to L (side weir length)

$$L = \frac{3}{2} \cdot \frac{Q_A}{\mu^x \cdot \sqrt{2g} \cdot h_m^{3/2}} \text{ (m)}$$

with $\mu^x = 0.95 \cdot 0.7$ (round-crested weir) = 0.67

Hence it follows

$$L = \frac{3}{2} \cdot \frac{0.4}{0.67 \cdot \sqrt{2 \cdot 9.81} \cdot 0.18^{3/2}} = 2.65\text{m}$$

Control whether the discharge to the side weir is flowing:







approach velocity

$$v_0 = \frac{Q_0}{B_0(h_0 + w)} = \frac{8}{6.0(0.17 + 1.00)} = 1.14\text{m/s}$$

Froude's number

$$F_0 = \frac{v_0}{\sqrt{g(h_0 + w)}} = \frac{1.14}{\sqrt{9.81(0.17 + 1.00)}} = 0.34 < 0.75$$

The required discharge is thus flowing!

Crest form	μ
 flood: sharp edges	0.49-0.51
 flood: round edges	0.50-0.55
 round crest	0.70
 sloped crest	0.64
 rounded	0.75
 roof-shaped	0.73

Weir coefficient μ for various weir forms (according to Press/Schroder [3])

II. During a flood event, the discharge can rise to $Q_0 = 45 \text{ m}^3/\text{s}$ (cf. Fig. 1). In this case, the water level is 2.50 m, the river width $B_0 = B_U =$ about 10 m.

For the weir dimensions fixed under item I, the discharge is to be determined which is evacuated during the flood discharge via the side weir!

Note:

All values in the tail water are now unknown, as the evacuated discharge Q_A and, as a result, also $Q_U = Q_0 - Q_A$ must first be determined.

Course of calculation

- Elevation of water surface above side weir crest upstream of the side weir:

$$t_0' = t_0 - w = 2.50 \text{ m} - 1.00 \text{ m} = 1.50 \text{ m.}$$

1st step:

- Estimate of the mean weir head:

$$h_m = \text{about } 1.30 \text{ m}$$

- Determination of the discharge with h_m estimated:

$$Q_A = \frac{2}{3} \cdot \mu^x \cdot L \cdot \sqrt{2g} \cdot h_m^{3/2} \quad (\text{values cf. I})$$

$$= \frac{2}{3} \cdot 0.67 \cdot 2.65 \cdot \sqrt{2 \cdot 9.81} \cdot 1.30^{3/2} = 7.8 \text{ m}^3 / \text{s}$$

- Hence the residual water amount follows:

$$Q_U = Q_0 - Q_A = 45 - 7.8 = 37.2 \text{ m}^3/\text{s}$$

- The corresponding water depth t_u is:

$t_u \sim 2.15$ m (for the determination, cf. also course of calculation in the relevant literature)

- Energy head h_{Eu} :

$$v_u = \frac{Q_u}{B_u \cdot t_u} = \frac{37.2}{10.0 \cdot 2.15} = 1.7 \text{ m/s}$$

$$h_{Eu} = t_u + \frac{v_u^2}{2g} = 2.15 + \frac{1.7^2}{2 \cdot 9.81} = 2.30 \text{ m}$$

- Determination of h_0 by iterative solution of the equation:

$$(h_0 + w)^3 - h_{Eu}(h_0 + w)^2 + \alpha \cdot \frac{Q_0^2}{2g \cdot B_0^2} \cong 0$$

$$(h_0 + 1.00)^3 - 2.30(h_0 + 1.00)^2 + 1.1 \frac{45^2}{2 \cdot 9.81 \cdot 10.0^2} \cong 0$$

The solution follows for the value

$$h_0 = 1.0 \text{ m}$$

- New mean weir head:

$$h_m \text{ new} = (1.0 + 1.15) / 2 = 1.08 \text{ m}$$

$$\text{with: } h_u = t_u - w = 2.15 - 1 = 1.15 \text{ m}$$

- New discharge Q_A to be evacuated over the side weir:

$$Q_{A \text{ new}} = \frac{2}{3} \cdot \mu^x \cdot L \cdot \sqrt{2g} (h_m \text{ new})^{3/2} = \frac{2}{3} \cdot 0.67 \cdot 2.565 \cdot \sqrt{2 \cdot 9.81} \cdot 1.08^{3/2}$$

$$Q_{A \text{ new}} = 6 \text{ m}^3$$

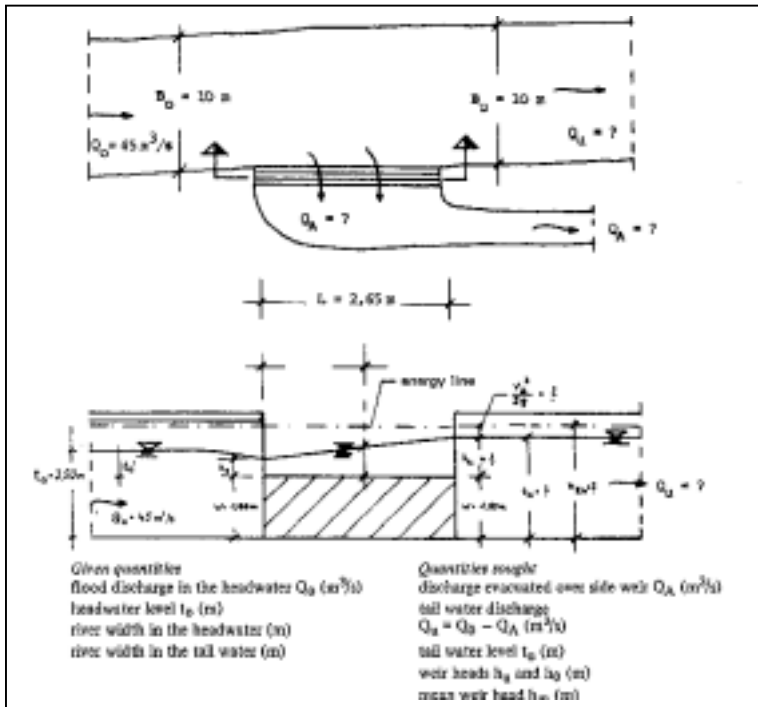

Fig. 1: Overflow over a straight side weir - flood event (numerical example)

2nd step:

(check whether the new estimated mean weir head must be improved)

- Residual amount of water:

$$Q_U = Q_0 - Q_A \text{ new} = 45 - 6 = 39 \text{ m}^3/\text{s}$$

- Tail water depth:

$t_U \sim 2.20 \text{ m}$ (for the course of calculation, cf. relevant literature)

- Weir head h_U :

$$h_U = t_U - w = 2.20 - 1.00 = 1.20 \text{ m}$$

- Energy head h_{Eu} :

$$v_u = \frac{Q_u}{B_u \cdot t_u} = \frac{39}{10 \cdot 2.2} \cong 1.8 \text{ m/s}$$

$$h_{Eu} = t_u + \frac{v_u^2}{2g} = 2.20 + \frac{1.8^2}{2 \cdot 9.81} = 2.37 \text{ m}$$

- Determination of h_0 :

$$(h_0 + w)^3 - h_{Eu}(h_0 + w)^2 + \alpha \cdot \frac{Q_0^2}{2g \cdot B_0^2} \cong 0$$

$$(h_0 + 1.00)^3 - 2.37(h_0 + 1.00)^2 + 1.1 \frac{45^2}{2 \cdot 9.81 \cdot 10^2} \cong 0$$

The iterative solution yields:

$$h_0 = 1.12 \text{ m}$$

- Mean weir head:

$$h_m = \frac{h_0 + h_u}{2} = \frac{1.12 + 1.20}{2} = 1.16 \text{ m}$$

- New discharge Q_A to be evacuated:

$$Q_{A \text{ new}} = \frac{2}{3} \cdot \mu^x \cdot L \cdot \sqrt{2g} (h_m \text{ new})^{3/2} = \frac{2}{3} \cdot 0.67 \cdot 2.65 \cdot \sqrt{2 \cdot 9.81} \cdot 1.16^2$$

$$Q_{A \text{ new}} = 6.6 \text{ m}^3/\text{s}$$

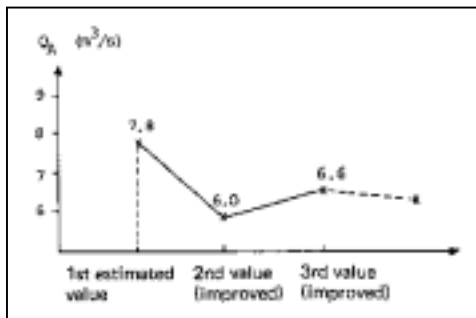

After this 2nd step of improvement, the procedure can be interrupted, as the values for Q_A are no longer improved considerably. In this example, the exact value for Q_A lies between 6 and 6.6 m³/s!

- Check whether the inflow into the headwater is flowing:

$$F_0 = \frac{v_0}{\sqrt{g(h_0 + w)}} \leq 0.75$$

$$v_0 = \frac{Q_0}{B_0(h_0 + w)} = \frac{45}{10(1.12 + 1.00)} = 2.1 \text{ m/s}$$

$$F_0 = \frac{2.1}{\sqrt{9.81(1.12 + 1.00)}} = 0.46 < 0.75$$

The required flowing discharge is given!

Annex 7: Calculation example for the outflow below a dam wall

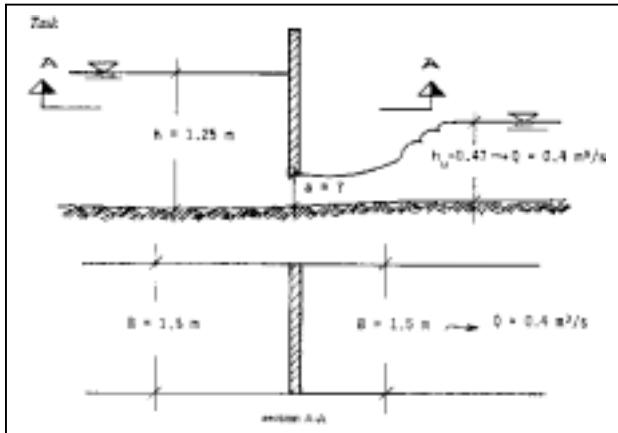

Case 1: Free outflow

At times of low water the headwater level before the dam wall should be at least $h = 1.25$ m. Which size must the sluice opening be in order that for a small hydroelectric power plant an amount of water for power generation $Q_A = 0.40$ m³/s might be evacuated in a canal with the width $B = 1.5$ m?

Further characteristic values of the canal:

gradient: $I = 1\text{‰}$

roughness coefficient: $k_S = 40$

This allows h_u to be calculated:

$$Q = A \cdot v = B \cdot h_u \cdot v \text{ in m}^3/\text{s}$$

$$\text{with } v = k_S \cdot R^{2/3} \cdot I^{1/2} \text{ in m}^3/\text{s}$$

with $R = (B \cdot h_u) / (B + 2h_u)$ for the rectangular cross-section

$$Q_A = 0.40 = B \cdot h_u \cdot k_S \cdot \sqrt{I} \cdot \left(\frac{B \cdot h_u}{b + 2 \cdot h_u} \right)$$

$$0.40 \cong 1.5 \cdot 40 \cdot \sqrt{0.001} \cdot h_u \cdot \left(\frac{1.5 \cdot h_u}{1.5 + 2 \cdot h_u} \right)^{2/3}$$

$$0.40 \cong 1.9 \cdot h_u \cdot \left(\frac{1.5 \cdot h_u}{1.5 + 2 \cdot h_u} \right)^{2/3}$$

By iterative introduction of different h_u values (estimates), the following results:

1st estimate

with $h_u = 0.45$:	$0.40 = 1.9 \cdot 0.45 \cdot (0.43)$
	$0.40 \neq 0.37$

2nd estimate

with $h_U = 0.5$:	$0.40 = 1.9 \cdot 0.5 \cdot 0.45$
	$0.40 \neq 0.43$

3rd estimate

with $h_U = 0.47$:	$0.40 = 1.9 \cdot 0.47 \cdot 0.437$
	$0.40 \neq 0.39$

$h_U = 0.47\text{m}$

By transformation of the equation for the outflow below sluices with respect to a, the following equations are obtained:

$$a = \frac{Q}{k \cdot \mu \cdot B \cdot \sqrt{2gh}} \text{ in m with } k = 1 \text{ for free outflow}$$

$$a = \frac{0.4}{1 \cdot 0.6 \cdot 1.5 \cdot \sqrt{2g \cdot 1.25}} = \frac{0.4}{4.457} = 0.09\text{m}$$

The check whether the assumption is correct that the outflow is free is carried out as follows:

$$h/a = 1.25/0.09 = 13.9$$

According to Fig. 38d), for $\delta = 0.7$ a limiting value $h_U / a = 5.8$ results.

h_U / a existing amounts to $0.47 / 0.09 = 5.22 < 5.8$ limiting value, i.e. the assumption that the outflow is free was correct.

Case 2: Submerged outflow

During the times of low water, the headwater level behind a dam wall is $h = 1.25$ m. It is to be determined which sluice opening will be necessary if in a canal with the parameters

$$k_S = 40$$

$$I = 0.5\text{‰}$$

and a sluice width $B = 1.0$ m which corresponds to the canal width, $Q_A = 0.4$ m³/s is to be evacuated. First h_U is calculated:

$$Q_A = b \cdot h_u \cdot k_S \cdot \sqrt{I} \left(\frac{B \cdot h_u}{B + 2 \cdot h_u} \right)^{2/3}$$

$$0.4 \cong 1.0 \cdot 40 \cdot \sqrt{0.0005} \cdot h_u \left(\frac{1 \cdot h_u}{1 + 2 \cdot h_u} \right)^{2/3}$$

Iterative solution of h_U

1st estimate:

with $h_U = 0.9$:	$0.4 = 1.0 \cdot 0.0005^{1/2} \cdot 0.9 (1 \times 0.9/2.8)^{2/3}$
	$0.4 = 0.8 \cdot 0.47$
	$0.4 \neq 0.38$

2nd estimate:

with $h_U = 0.93$:	$0.4 = 1.0 \times 40 \times 0.0005^{1/2} \times 0.93 \times (0.93 / 2.86)^{2/3}$
	$0.4 = 0.832 \cdot 0.473$
	$0.4 = 0.39$

i.e. the 2nd estimate with $h_U = 0.93$ was correct.

Assumption: submerged outflow opening a in first approximation with $k = 0.8$

$$a = \frac{Q}{k \cdot \mu \cdot B \cdot \sqrt{2gh}} = \frac{0.4}{0.8 \cdot 0.6 \cdot 1 \cdot \sqrt{2 \cdot 9.81 \cdot 1.25}}$$

$$a = \frac{0.4}{0.48 \cdot \sqrt{24.53}} = \frac{0.4}{2.38} = 0.17\text{m}$$

$$\text{Check: } h / a = 1.25 / 0.17 = 7.35$$

with $\delta = 0.7$ according to Fig. 38d), a limiting value $h_U / a = 4.3$ results.

$$\text{exist. } h_U / a \text{ is: } 0.93 / 0.17 = 5.47 > 4.3$$

i.e. the assumption that the outflow is submerged was correct.

According to Fig. 38e), for $h_U / a = 5.47$ and $h / a = 7.35$, a k value of 0.5 results.

New calculation of a :

$$a = \frac{0.4}{0.5 \cdot 0.6 \cdot 1.0 \cdot \sqrt{24.53}} = \frac{0.4}{1.48} = 0.27$$

Hence it follows:

$$h / a = 1.25 / 0.27 = 4.63 \text{ @ limiting value } a = 3 \text{ for } d = 0.7$$

$$h_U / a = 0.93 / 0.27 = 3.44 > 3 \text{ submerged outflow}$$

With Fig. 38e), for h_U / a and $h / a = 4.63$, the following k value is obtained:

$$k \sim 0.5$$

The k value is in agreement. Hence it follows that in the case of submerged outflow, $Q_A = 0.4 \text{ m}^3/\text{s}$ can be evacuated below the sluice with an opening width of 0.27 m in the tail water canal.

Annex 8: Calculation example for a bottom intake (Tyrolean weir)

At right angles with a river (stream) a Tyrolean weir is to be built in order to divert an amount of water for power generation $Q_A = 0.85 \text{ m}^3/\text{s}$. In this point the river width is about 8 m; at times of low water, the minimum headwater depth (= initial water height) is $h_0 = 0.5 \text{ m}$. The Tyrolean weir with the collection canal is to be dimensioned in such a way that the diversion of the amount of water for power generation $Q_A = 0.85 \text{ m}^3/\text{s}$ is always ensured at times of low water.

Selected quantities (numerical example)

- contraction coefficient for trash rack	$\mu \sim 0.85$ (round bars)
- internal width between bars	$a = 2 \text{ cm}$
- centre distance between bars	$d = 4 \text{ cm}$
- inclination of trash rack	$\beta = 8^\circ$

Hence the following values result for

- $h = 2/3 k h_0 = 2/3 \cdot 0.927 \cdot 0.5 = 0.31 \text{ m}$
- $c = 0.6 a/b \cos^{3/2} \beta = 0.6 \cdot 2/4 \cos^{3/2} 8^\circ$
- $c = 0.3$

With these values the discharge through the trash rack first results as a function of the width b and the length L of the trash rack:

$$Q_A = \frac{2}{3} \cdot c \cdot \mu \cdot b \cdot L \cdot \sqrt{2 \cdot g \cdot h} = \frac{2}{3} \cdot 0.3 \cdot 0.84 \cdot b \cdot L \cdot \sqrt{2 \cdot 9.81 \cdot 0.31} = 0.419 \cdot b \cdot L$$

With $Q_A = 0.85 \text{ m}^3/\text{s}$, the following is obtained:

$$0.85 = 0.419 b L$$

$$0.85 / 0.419 = b L$$

$$b L = 2.03 \text{ or } L = 2.03 / b \text{ (m)}$$

width of trash rack b (m)	2	4	6
length of trash rack L (m)	1.00	0.51	0.34

- Selected width of trash rack: $b = 4 \text{ m}$
- To this width the length L of the trash rack corresponds:

$$L = 2.03/b = 2.03/4 = 0.51 \text{ m}$$

- The selection of the width and the corresponding length- of the trash rack should be governed by the following criteria:

adaptation of the Tyrolean weir to the local conditions,
 selection of a sufficiently great trash rack length which determines the width of the collection canal arranged below. If the length of the trash rack is selected too small this collection canal for the evacuation of the water for power generation must be constructed deeper and,

as a result, less economically, as for constructional reasons, it should have approximately the same width as the projection of the length of the trash rack onto the horizontal ground area.

During-operation, parts of the trash rack can be obstructed by wedged stones, leaves or branches so that the evacuation of the minimum amount of water can no longer be ensured. This is why the determined trash rack length L should be increased by 20%:

$$L = 1.2 \cdot 0.51 = 0.61 \text{ m.}$$

Dimensioning of the collection canal

Along the trash rack width b (= weir width), the amount of water for power generation falling through the trash rack increases linearly and reaches its maximum in the end cross section of the collection canal. For reasons of simplicity, this end cross-section is used for the dimensioning of the canal:

- Selected quantities (numerical example):

canal width	B = 0.65 m,
roughness	$k_S = 50$ (concrete),
slope	I = 30‰

(The slope should at least be 30‰ in order to remove again from the collection canal the solid matter entrained, by a high tractive force of the water. For this purpose, a higher water velocity is necessary which chiefly depends upon the slope of the collection canal.)

- Sought: water depth t

Discharge formula for channels (rectangular)

$$Q_A = B \cdot t \cdot k_S \cdot I^{1/2} \cdot \left(\frac{B \cdot t}{B + 2 \cdot t} \right)^{2/3} \text{ (m}^3/\text{s)}$$

Introduction of the values:

$$Q_A = 0.85 \text{ m}^3/\text{s} = 0.65 \cdot t \cdot 50 \cdot (0.03)^{1/2} \cdot \left(\frac{0.65 \cdot t}{0.65 + 2 \cdot t} \right)^{2/3}$$

$$0.85 = 5.6 t (0.65 t / (0.65 + 2 \cdot t))^{2/3}$$

Iterative solution of the equation by inserting different values for t:

solution:	t = 0.46 m
freeboard:	0.25 · t = 0.12 m
total canal depth:	0.46 m + 0.12 m = 0.58 m

Annex 9: Numerical example of the proof of safety from hydraulic shear failure

(1) Representation of the weir with headwater and tail water level for the design case in question (lowest discharge, as in this case the hydraulic gradient Dh is greatest; cf. Fig. 1).

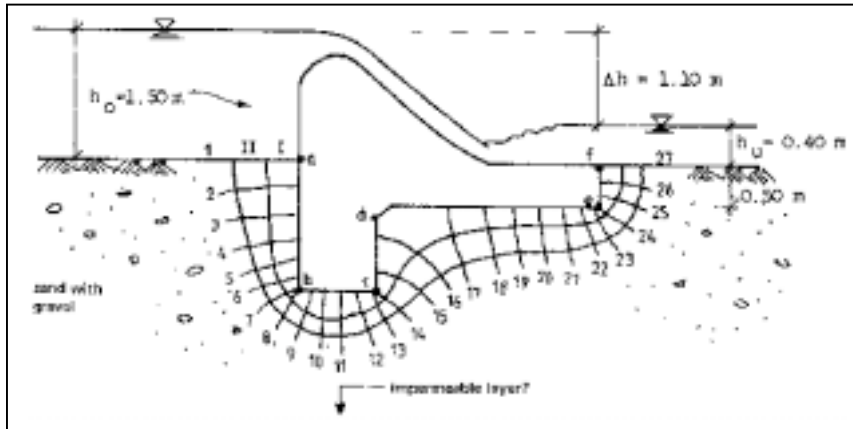

Fig. 1: Potential and stream line net for determining the safety from hydraulic shear failure. I, II flow channels, 1-27 potential lines

(2) Construction of the potential and streamline net:

- start with potential line No. 11 in the middle of the weir toe running vertically towards the bottom
- determination of the number of flow channels and entry of the approximate run of the streamlines
- entry of the potential lines beginning with the bottom flow channel in the direction of the weir foundation.
- Attention: On the bottom flow channel the potential lines must be equidistant.
- Numerical example (cf. Fig. 1):
 number of flow channels 2
 number of potential steps $n_S = 27$
- Critical hydraulic gradient

$$l_{\text{crit.}} = (1 - n) (\gamma_f / \gamma_w - 1)$$

$$n \sim 0.35 \text{ (sand/gravel)}$$

$$\gamma_f \sim 20 \text{ kN/m}^3 \text{ (sand/gravel)}$$

$$\gamma_w \sim 10 \text{ kN/m}^3 \text{ (water)}$$

$$l_{\text{crit.}} = (1 - 0.35) (20 / 10 - 1) = 0.65 \cdot 1.0 = 0.65$$

- Existing gradient in the critical point (= point f)

$$l_{\text{exist.}} = Dh / (n_S \times D_n S)$$

$$Dh = h_0 - h_u = 1.50 - 0.40 = 1.10 \text{ m}$$

$$n_S = 27 \text{ potential lines}$$

$$\Delta n S \sim 0.50 \text{ m} / 3 = 0.17 \text{ m} \text{ (= mean distance between potential lines 26 and 27 = mean distance between all potential lines)}$$

$$I_{\text{exist.}} = 1.10 / (27 \cdot 0.17) = 0.24$$

- Safety from hydraulic shear failure

$$v = I_{\text{crit.}} / I_{\text{exist.}} = 0.65 / 0.24 = 2.7 \approx 2.0$$

This means that in the critical zone (outlet into the tail water) no hydraulic shear failure will occur.

Annex 10: Numerical example of the proof of stability against sliding of a fixed weir

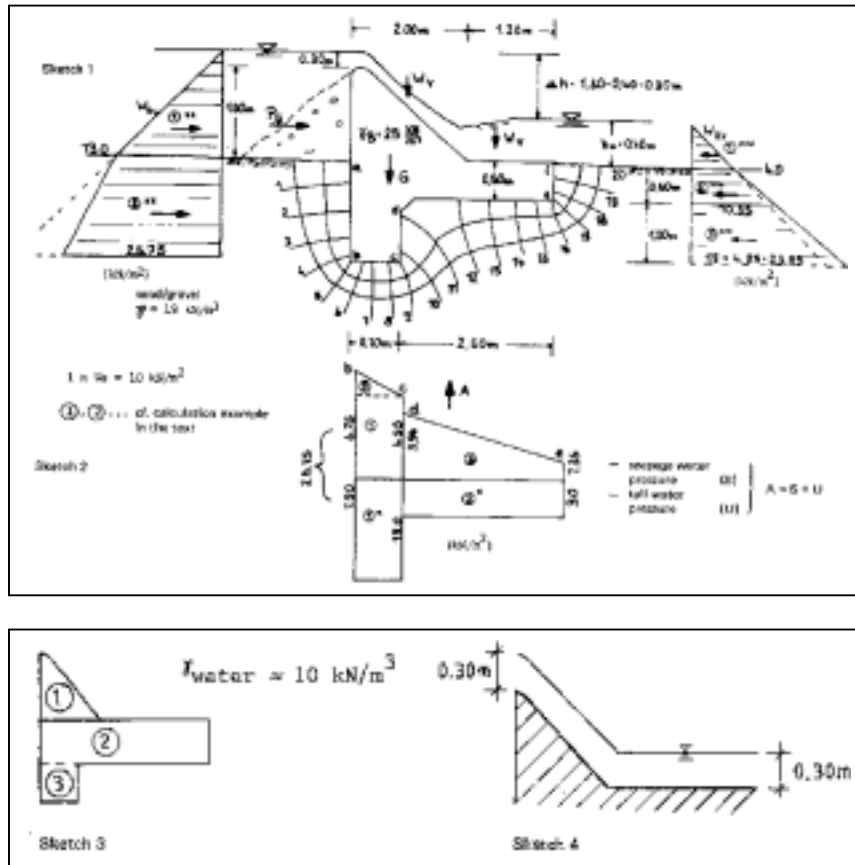

Fig. 1: Numerical example for determining the stability against sliding of a fixed weir

For the weir subject to underflow represented in Fig. 1, the stability against sliding is to be determined. The given quantities can be seen in the figure. All the forces are related to a weir width of 1 m.

Vertical forces:

- Weight of the structure (sketch 3) (g concrete ~ 25 kN/m³):

$$G = 1/2 \cdot 25 \cdot 2.00 \cdot 1.00 + 25 \cdot 3.20 \cdot 0.5 + 25 \cdot 0.7 \cdot 1.0 = 25 + 40 + 17.5 = 82.5 \text{ kN}$$

(1) (2) (3)

- Water surcharge (estimate) (sketch 4):

$$W_V \sim 1.20 \cdot 0.30 \cdot 10 \cdot 2.00 \cdot 0.30 \cdot 10 = 9.6 \text{ kN}$$

- Force due to seepage water pressure (sketch 2):

$$S = 4.95 \cdot 0.7 + 1/2 \cdot (6.75 - 4.95) \cdot 0.7 + 1/2 \cdot (3.95 + 1.35) \cdot 2.50 = 3.47 + 0.63 + 6.64 = 10.74 \text{ kN}$$

(1) (2) (3)

- Force due to tail water pressure (sketch 2):

$$U = 19.0 \cdot 0.7 + 9.0 \cdot 2.50 = 13.3 + 22.5 = 35.8 \text{ kN}$$

(1)^x (2)^x

- Sum of vertical forces:

$$\sum V = G + W_V - S - U$$

$$= 82.5 + 9.6 - 10.74 - 35.8 = 45.56 \text{ kN}$$

Horizontal forces (sketch 1):

- Headwater:

$$W_{H1e} = 1/2 \cdot 13.0 \cdot 1.30 + 1/2 \cdot (25.75 + 13.0) \cdot 1.50$$

(1)^{xx} (2)^{xx}

$$= 8.45 + 29.10 = 37.55 \text{ kN}$$

- Tail water:

$$W_{Hr} = 1/2 \cdot 4.0 \cdot 0.4 + 1/2 \cdot (4 + 10.35) \cdot 0.50 + 1/2 \cdot (10.35 + 23.95) \cdot 1.0$$

(1)^{xxx} (2)^{xxx} (3)^{xxx}

$$= 0.80 + 3.60 + 17.15 = 21.55 \text{ kN}$$

- Bed load pressure:

$$P_G \sim 1/2 \cdot (19 - 10) \cdot 1^2 = 4.5 \text{ kN}$$

- Sum of horizontal forces:

$$\sum H = W_{H1e} + P_G - W_{Hr}$$

$$= 37.55 + 4.5 - 21.55 = 20.5 \text{ kN}$$

Stability against sliding

$$v_G = \frac{\sum V \cdot \tan \phi}{\sum H}; \text{ with } \tan \phi = 0.6 \text{ (rubble/gravel/sand)}$$

$$= (45.56 \times 0.60) / 20.5 = 1.3 < 1.50$$

With these given dimensions of the fixed weir, the necessary stability against sliding would not be

ensured. To increase the stability against sliding the measures described in section 4.2 must be taken (extension of the stilling basin, deepening of the toe wall below the weir crest, etc.).

Annex 11: Calculation example for the design of a sand trap

(1) Determination of the grain-size limit

According to the operational requirements, the particle diameter of the suspended matter is determined which is just to be caused to settle.

In practice, a grain-size limit of 0.2 mm has proved to be suitable (low-head and high-head power plants). In the case of a head > 100 m and pure quartz sand, $d_{\text{limit}} = 0.05$ mm is selected (exceptional case).

(2) Determination of the flow velocity

The flow velocity v_d in the sand trap must not exceed an upper limiting value if the limited grain size is to be deposited. $v_d = a \cdot d^{1/2}$ in cm/s

d = particle diameter a = coefficient as a function of d
 $a = 36$ at $d > 1$ mm
 $a = 44$ at $0.1 \text{ mm} < d < 1$ mm
 $a = 51$ at $d < 0.1$ mm

for $d = 0.2$ mm:

$$\rightarrow v_d = 44 \sqrt{0.2} = 19.7 \text{ cm/s}$$

In practice, for a limited grain size of 0.2 mm, a flow velocity of

$$v_d = 0.2 \text{ m/s}$$

has proved to be suitable.

(3) Determination of sand trap dimensions

- Length of sand trap:

$$L = \frac{v_d \cdot h}{v_s - 0.04 \cdot v_d} \text{ in m}$$

with L = effective settling length in m
 h = settling depth in m
 v_d = flow velocity in m/s
 v_s = sinking velocity of the limited grain size in m/s according to Fig. 1,
in dependence upon g_s / g_w
 γ_s = specific weight of the particles
 γ_w = specific weight of water e.g. for sand: $s = 2.7$

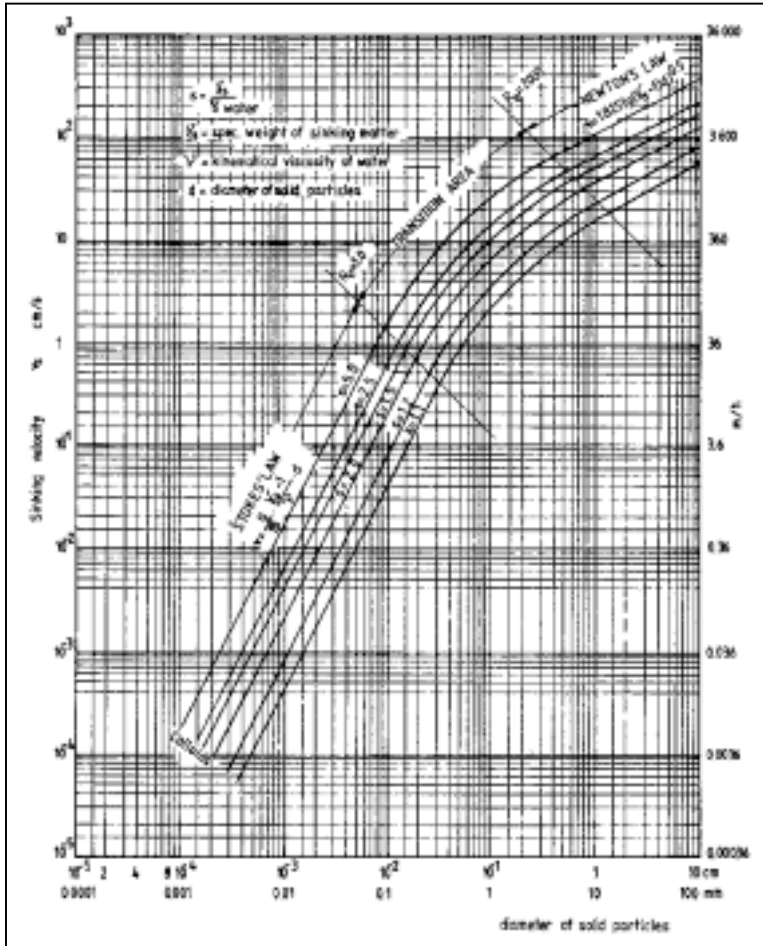

Fig. 1: Sinking velocity of spherical particles in still water at 10 °C. (At other water temperatures, the values in the range of Stokes' law are to be multiplied by $v/(1.31 \cdot 10^{-2})$.) Source [12]

Note: If the denominator is negative, other conditions will have to be selected. Settling is then not possible.

- Width of sand trap:

$$B = \frac{Q \cdot t_d}{L \cdot h} \text{ in m}$$

$$t_d = L / v_d \text{ in s}$$

with Q = discharge in m^3/s
 t_d = time of passage in s

In order to achieve a uniform approach of the water over the whole chamber width, the transition section is to be designed according to Fig. 2.

The selected settling depth is $h = 1 \text{ m}$ with limited grain size = 0.2 mm

$$v_d = 0.2 \text{ m/s}$$

$$s = 2.7 \rightarrow v_s = 2.8 \text{ cm/s}$$

$$a = 12^\circ$$

$$\rightarrow L = \frac{v_d \cdot h}{v_s - 0.04 \cdot v_d} = \frac{0.2 \cdot 1}{0.028 - 0.04 \cdot 0.2} = \frac{0.2}{0.02} = 10\text{m}$$

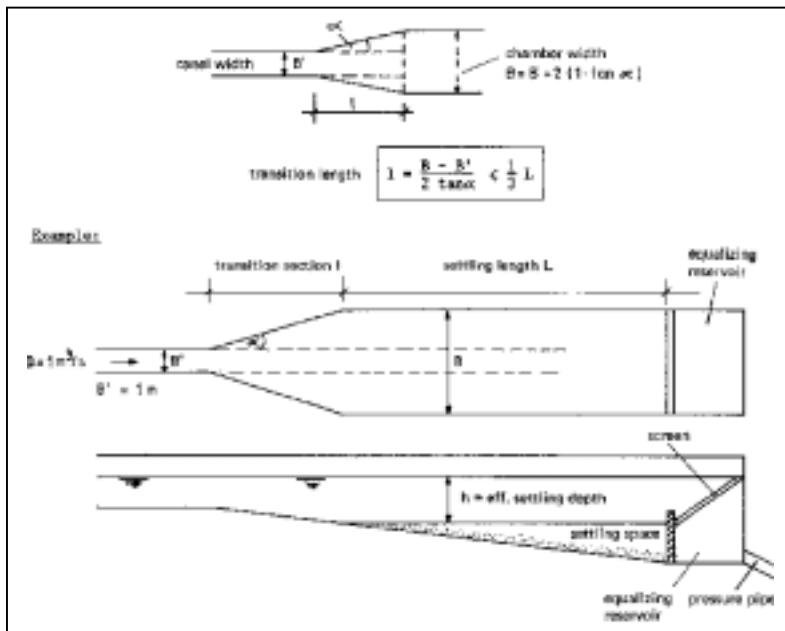

Fig. 2

Determination of B:

$$B = (Q t_d) / (L \cdot h) \text{ with } t_d = L / v_d = 10 / 0.2 = 50 \text{ s}$$

$$\rightarrow B = (1 \cdot 50\text{s}) / (10 \cdot 1) = 5 \text{ m}$$

Check for the sand trap dimensions:

$$l = \frac{B - B'}{2 \cdot \tan \alpha} = \frac{5 - 1}{2 \cdot \tan 12^\circ} = 9.4\text{m} > \frac{L}{3}$$

i.e. l is too long.

New choice of the sand trap width:

$$h = 1.5 \text{ m}$$

$$\rightarrow L = 0.2 \cdot 1.5 = 15 \text{ m}$$

$$B = 1 \cdot 74\text{s} / (15 \cdot 1.5) = 3.33 \text{ m } t_d = 15 / 0.2 = 75\text{s}$$

Check:

$$l = \frac{3.33 - 1.0}{2 \cdot 0.02126} = 5.49\text{m} \approx \frac{L}{3}$$

$$\text{with } \alpha = 14^\circ \quad l = \frac{3.33 - 1.0}{2 \cdot 0.2126} = 4.68 < \frac{L}{3}$$

As a result, the sand trap dimensions are selected as follows:

L = 15 m
h = 1.5 m
B = 3.4 m
l = 4.7 m
a = 14°

List of symbols

A	= area = branch of a river = buoyancy in kN = cross-section of flow = runoff during an observed period of time T
A_{E0}	= precipitation area = total catchment area surface in m^2 or km^2
A_i	= partial area of a partial catchment area in m^2 or km^2
$A_{1,2..}$	= partial area of station 1, 2 . .
a	= aerated area between tail water and top of the weir crest = calibrated parameter for current meter (given by manufacturer of the instrument) = height of the sluice opening = inside width between trash rack / sluice bars = coefficient dependent upon particle diameter
B, b	= width of weir, canal
b	= calibrated parameter for current meter (given by manufacturer of the instrument) = width of trash rack / screen
C	= concentration of suspended matter
C_s	= content of suspended matter
c	= correction coefficient = coefficient of resistance of particles
D	= equivalent diameter ($4 F / U = 4 \cdot B \cdot h / (B + 2h)$)
d	= distance between the trash rack / screen bars = particle diameter
E	= catchment area
F	= cross-sectional area = Froude's number
F_i	= individual surface fractions
f_v	= velocity area
f_{vm}	= mean velocity area
G	= weight of the structure in kN
g	= acceleration due to gravity = 9.81 m/s^2
H	= horizontal forces = main stream, main river
HHQ	= highest discharge
HQ	= flood discharge
HQ ₁₀₀	= 100-yearly flood
HW	= high-water level
h	= depth of water at the vertical lines of measurement = elevation of water surface = impounding head = water level
h_A	= runoff rate of the AEO during a certain period of time (T) in mm
h_E	= energy head
h_N	= height of precipitation above AEO during a certain period of time (T) in mm = heavy precipitation
h_R	= retention rate in the AEO during a certain period of time (T) in mm
h_V	= evaporation height in the AEO during a certain period of time (T) in mm

h_m	= mean weir head
$h_{\ddot{u}}$	= weir head
$h_{\ddot{u}e}$	= head of diversion weir
$h_{\ddot{u}s}$	= head of retaining weir
I	= slope, gradient
i_N	= intensity of precipitation in mm/hour
k	= correction factor
k_S	= roughness coefficient
L	= length of structure = length of trash rack / screen
l	= length of transition area (sand trap)
MMQ	= mean monthly discharges of all years observed
MQ	= mean monthly discharges of one year
MW	= mean water level
m_G	= bed load movement
n_{iG}	= bed load transport
m_{Gf}	= bed load
m_{Sf}	= suspended matter load
m_{Sf}	= suspended matter transport
N	= precipitation
N_G	= area precipitation
NNW	= lowest low-water level
NQ	= low discharge
NW	= low-water level
N_i	= precipitation of the station i
$N_{1,2,\dots}$	= point precipitation of station 1, 2 . . .
n	= correction coefficient = number of events = number of revolutions per unit of time = pore volume proportion
n_i	= number of potential steps in flow direction up to the point i being sought
n_S	= number of potential lines = number of potential steps
o	= index for headwater
P_G	= bed load pressure
P_{Si}	= seepage water pressure at a specific point i
P_u	= tail water pressure
Q	= discharge
Q_A	= discharge in the branch of a river = design discharge
Q_H	= discharge in the main river
$Q_{\ddot{u}}$	= discharge capacity over the weir
R	= retention in the catchment area during T (interception, infiltration)
Re	' = Reynolds' number
r_{hy}	= hydraulic radius
S	= seepage water pressure
s	= height of end sill = length of measurement section = density of particles due to density of water

T	= time, unit of time
	= recurrence interval
T_K	= time of concentration in hours
T_N	= duration of precipitation
T_R	= duration of precipitation
t	= water depth
$\tan \varphi$	= friction coefficient
t_d	= time of passage
t_s	= settling time, sinking time
U	= wetted perimeter
	= tail water pressure
u	= index for tail water
V	= evaporation above the catchment area during T
	= vertical forces
V_Q	= estimated discharge
v	= flow velocity
v_A	= flow velocity in the diversion canal
v_E	= flow velocity in, the settling basin
v_Z	= flow velocity in the inlet canal
v_d	= flow velocity in the settling basin
v_i	= individual velocity values
v_m	= mean flow velocity
v_S	= settling/sinking velocity of particles
v_S'	= mean settling/sinking velocity of particles
W_G	= height of the amount of bed load
W_H	= horizontal water pressure
W_{H1e}	= horizontal water pressure in the headwater
W_{Hr}	= horizontal water pressure in the tail water
W_V	= water surcharge on the structure
W_e	= height of diversion weir
W_S	= height of retaining weir
w	= weir crest height
	= dynamic buoyancy due to turbulent flow
x	= calibration factor
α	= angle of curvature / bend
	= velocity coefficient
β	= angle of inclination
γ_F	= specific weight of solid matter particles
γ_G	= specific weight of bed load
γ_S	= specific weight of particles / grains
γ_W	= specific weight of water
Δ	= difference
ΔZ_{el}	= difference of energy heads
δ	= contraction coefficient
μ	= discharge coefficient
	= weir coefficient
μ_X	= reduced weir coefficient
φ	= retardation coefficient

ν = kinematic viscosity of the water
 ν_G = stability against sliding
 ψ = runoff coefficient, discharge coefficient
 λ = loss coefficient

Bibliography

- [1] Karlsruhe University/DVWK: 1st basic course of hydrology, "Hydrologische Planungsunterlagen", Institute for Hydraulic Engineering III at the Karlsruhe University, April 1979
- [2] WMO: Guide to hydrological practices. Third edition. WMO No. 168, Secretariat of the World Meteorological Organization, Geneva, Switzerland, 1974
- [3] Press, H./Schröder, R.: Hydromechanik im Wasserbau. Verlag Ernst & Sohn, Berlin, Munchen, 1966
- [4] Ven te Chow: Handbook of applied hydrology. A compendium of water resources technology. McGraw-Hill Book Company, 1964
- [5] DVWK: Schwebstoffmessungen. Regeln zur Wasserwirtschaft, 1984 (yellow print)
- [6] Scheuerlein, R.: Die Wasserentnahme aus geschiebeführenden Flüssen. Verlag Ernst & Sohn, Berlin, 1984
- [7] Babanek, R.: Zur Elektrifizierung ländlicher Gebiete in Entwicklungslandern unter besonderer Berücksichtigung von Kleinwasserkraftanlagen. Institute for Hydraulic Engineering and Water Management, Vol. 39, Aachen Technical University, 1982, published by Prof. Dr. G. Rouvé
- [8] DVWK: Regeln zur Wasserwirtschaft. Empfehlungen zur Berechnung von Hochwasserwahrscheinlichkeiten. Vol. 101, 2nd edition 1979, Verlag Paul Parey
- [9] Ruppert, W./Vollhofer, O.: Chinas grosser Strom - Chinas grosse Sorge - Der Gelbe Fluss. Special print from China Report 51/52 80
- [10] Keller, S.: Triebwasserweg und spezifische Probleme von Hochdruckanlagen. In: Kleinwasserkraftwerke, Projektierung und Entwurf. Published by Prof. Dr. S. Radler, University for Soil Culture, Institute for Water Management, Vienna, 1981
- [11] Vischer, D./Huber, A.: Wasserbau. Hydrologische Grundlagen, Elemente des Wasserbaus, Nutz- und Schutzbauten an Binnengewässern. Third edition. Springer-Verlag, Berlin, 1982
- [12] Popel: Institute's publications of the Faculty for Domestic Hydraulic Engineering and Town Construction of the Stuttgart Technical University. A (3/2), 1963
- [13] Camp, in Mosonyi, E.: Wasserkraftwerke. Vol. II: Hochdruckanlagen, Kleinstkraftwerke und Pumpspeicheranlagen. Published by Hungarian Academy of Science, Budapest, 1959
- [14] Rehbock, Th.: Wassermengenmessung mit scharfkantigen Überfallwehren. ZVDI, 1929, Vol. 73, N° 24
- [15] Kresser, W.: Gedanken zur Geschiebe- und Schwebstoffführung der Gewässer. OWW, 1964, N° 1/2, p. 6-11