

TORSIONAL STRENGTH OF SLAB

- Fig. 12.10 has two horizontal beams joined together in mutually perpendicular directions.
- The bending moment in one of the beam at the common point acts as torque for the other beam.
- Part of the total load may be resisted by torsional strength of beams besides the usual flexural strength.

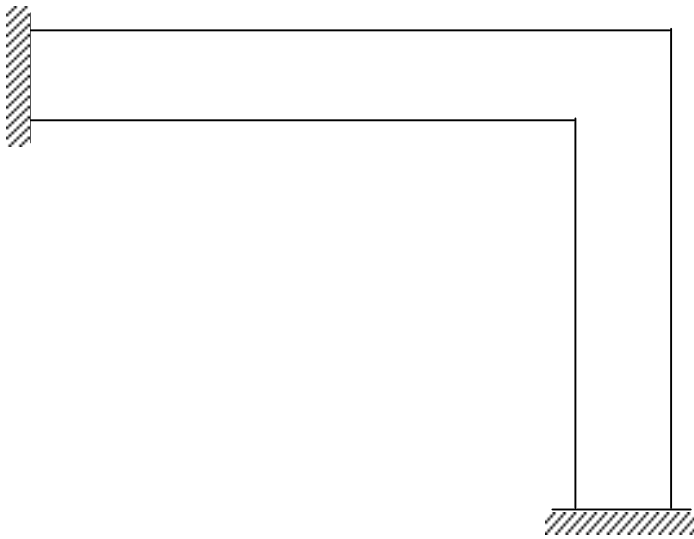

Fig. 12.10. Two Mutually Perpendicular Shallow Strip Beams Lying In Horizontal Plane.

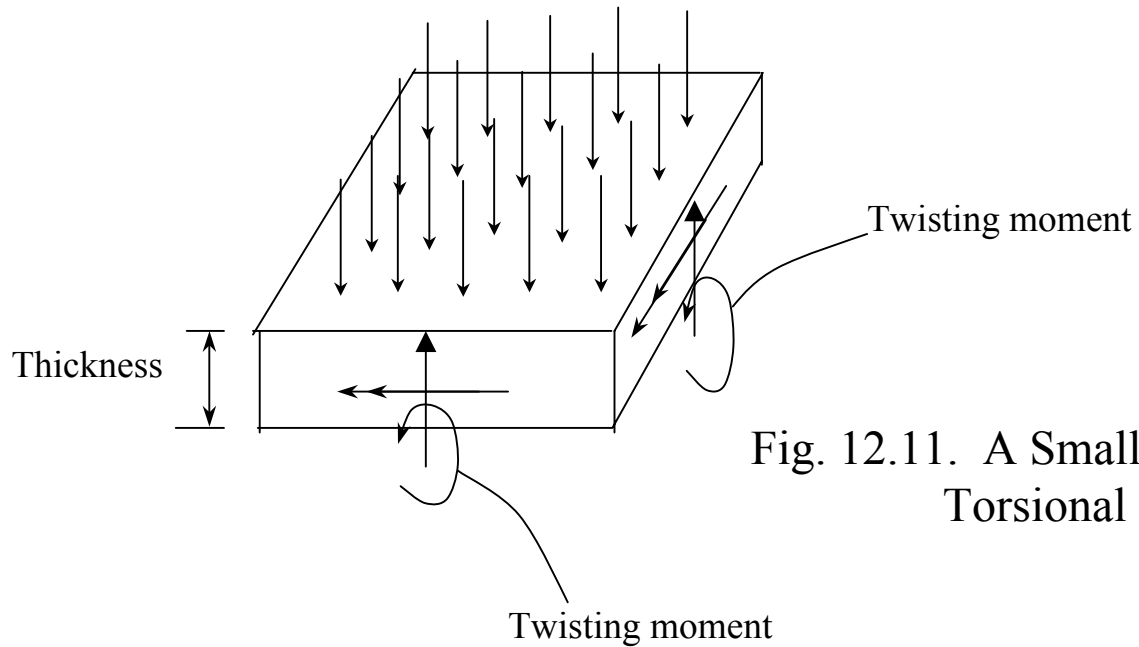

Fig. 12.11. A Small Element of Slab Having Torsional and Flexural Moments.

- Exactly in the same way, perpendicular design strips are connected to each other and loads are distributed in the two directions partially by the torsional strength.
- Due to this two-way action the bending stiffness at a particular section is increased by the presence of the perpendicular strips.
- For the perpendicular strips, bending moment and twisting moment are interchanged in the two perpendicular directions and hence the load is distributed in the two directions.
- It is clear that torsional stiffness of slab and beams is very important in determining the overall behavior of the slab system.

DIRECT DESIGN METHOD

Check For Limitations Of DDM

- First five restrictions of the direct design method are checked in this step and the 6th restriction will be considered later.
- These restrictions are as under:

- There is a minimum of three continuous spans in each direction.
- Panels are rectangular, with a ratio of center-to-center longer to shorter span ratio of each panel not greater than 2. This condition eliminates the possibility of one-way action of slabs.
- Adjacent center-to-center span lengths in each direction should not differ by more than one-third of the longer span.
- If the columns are not exactly present in a single line, a maximum offset of columns equal to 10% of the span in the direction of offset is allowed from between centerlines of successive columns.

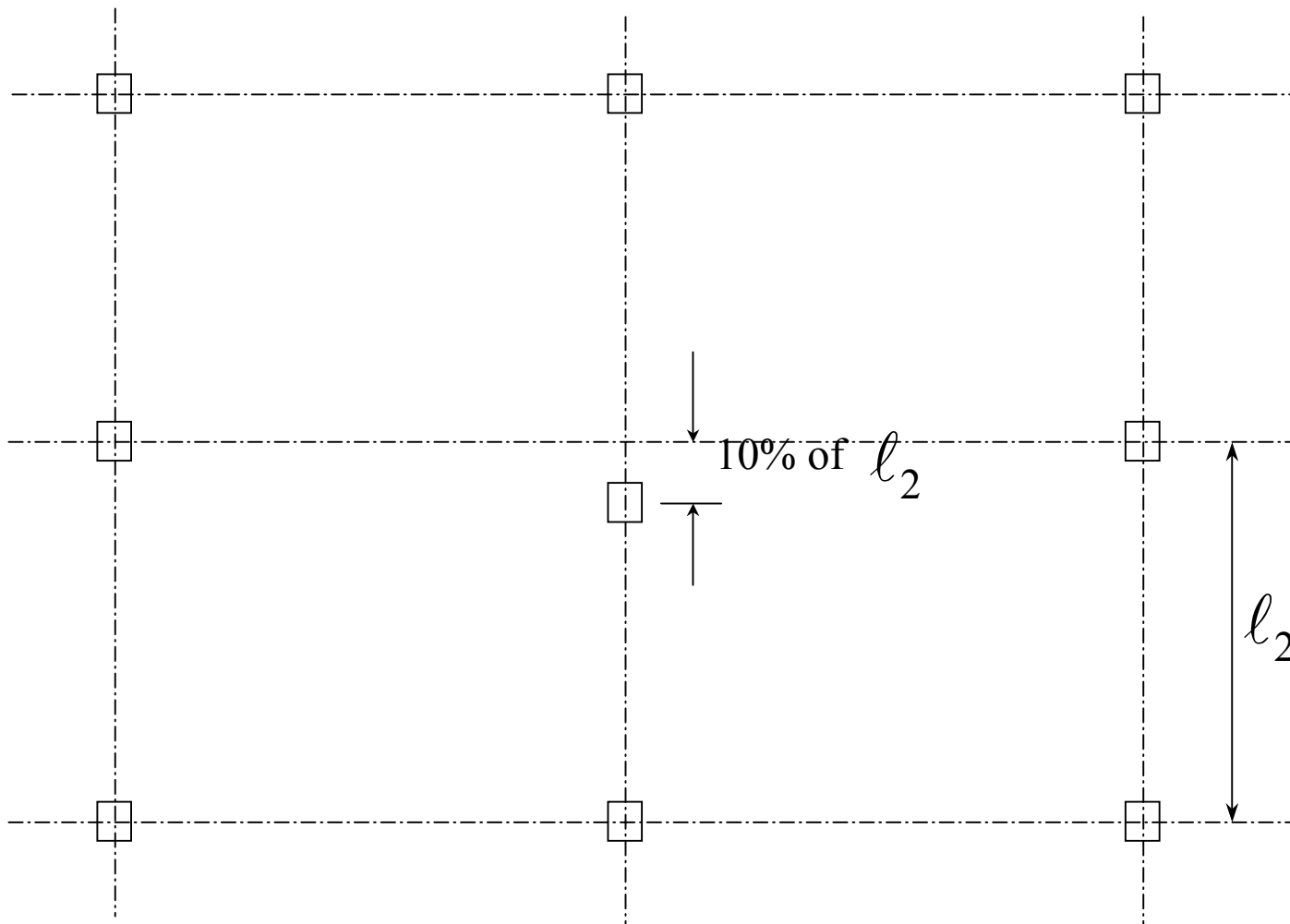

Fig. 12.12. Maximum Allowed Column Offset.

The direct design method is only applicable to uniformly distributed gravity loads. Separate analysis is to be made for concentrated loads or lateral loads. Further, live load should not exceed two times the dead load. The coefficients given in this method are for pattern loads up to the specified limit.

For a panel with beams between supports on all sides, the relative stiffness (α_f / ℓ) of beams in two perpendicular directions should not be less than 0.2 nor greater than 5.0.

$$\frac{\alpha_{f_1} \ell_2^2}{\alpha_{f_2} \ell_1^2} = \text{between } 0.2 \text{ to } 5.0$$

where α_f = ratio of flexural stiffness of beam section to flexural stiffness of a width of slab bounded laterally by centerlines of adjacent panels (if any) on each side of the beam.

$$= \frac{E_{cb} I_b}{E_{cs} I_s} = \frac{(EI)_{beam}}{(EI)_{slab}}$$

* Moment redistribution allowed by ACI 8.4 is not applicable to slab systems designed by the Direct Design Method.

Selection Of Slab Depth (ACI 9.5.3)

Two-Way Slab Depth Without Interior Beams

The minimum thickness is greater of the following values and that given by Table 12.1:

- Slabs without drop panels 120 mm
- Slabs with drop panels 100 mm

ℓ_n = length of clear span in long direction of two-way construction, measured face-to-face of supports in slabs without beams and face-to-face of beams or other supports in other cases.

Table 12.1. Minimum Slab Depth Without Interior Beams.

f_y (MPa)	Exterior panel + no drop panel + no edge beam	Exterior panel + either drop panel or edge beam (OR) Interior panel + no drop panel	Interior panel + drop panel (OR) Exterior panel + drop panel + edge beam
300	$l_n/33$	$l_n/36$	$l_n/40$
420	$l_n/30$	$l_n/33$	$l_n/36$
520	$l_n/28$	$l_n/31$	$l_n/34$

Note:-

Edge beam is considered to be present if $\alpha_m \geq 0.8$.

Two-Way Slab Depth With Beams On All Sides

$$\text{Let, } \alpha_f = \left(\frac{(EI)_b}{(EI)_s} \right)$$

and α_{fm} = average value of ' α_f ' for all beams on edges of a panel.

For slabs with beams spanning between the supports on all sides and denoting clear span in the long direction by ℓ_n , the minimum thickness required is determined as follows:

a) If $0.2 < \alpha_{fm} \leq 2.0$,

$$h_{\min} = \frac{\ell_n \left(0.8 + \frac{f_y}{1500} \right)}{36 + 5\beta(\alpha_{fm} - 0.2)} \quad \text{but not less than 120 mm}$$

b) If $\alpha_{fm} > 2.0$,

$$h_{\min} = \frac{\ell_n \left(0.8 + \frac{f_y}{1500} \right)}{36 + 9\beta} \quad \text{but not less than 90 mm}$$

where β = ratio of clear spans in long to short direction.

c) If $\alpha_{fm} < 0.20$, the provisions for slabs without interior beams must be applied.

- d) For panel with one or more discontinuous edges having edge beam with $\alpha_f < 0.8$, h_{\min} is to be increased by at least 10% in that panel. This increase is not required for slabs without interior beams and is not to be applied to the upper limit of 120 and 90 mm.

Trial Slab Depth

The maximum thickness for slabs without interior beams may be used as under:

$$h = \frac{\ell_n}{33} \geq 120 \text{ mm} \quad \text{for } f_y = 300 \text{ MPa}$$

$$h = \frac{\ell_n}{30} \geq 120 \text{ mm} \quad \text{for } f_y = 420 \text{ MPa}$$

For slabs with interior beams, α_m may be assumed to be greater than 2.0 and depth may be calculated using the corresponding formula. For very shallow beams, necessary increase in depth may be required.

Beam Stiffness

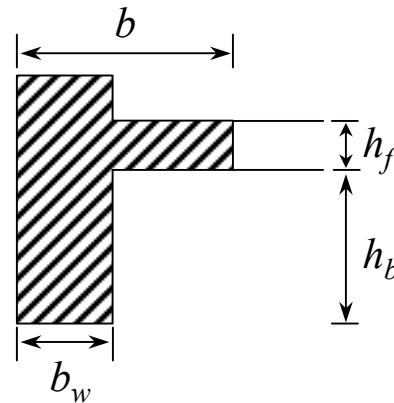

Fig. 12.13. Effective Slab Width For L-Beams

For L-beams, the effective width ' b ' is lesser of:

- i) $b_w + h_b$
- ii) $b_w + 4h_f$

For interior T-beams the effective width ' b ' is lesser of:

- i) $b_w + 2h_b$
- ii) $b_w + 8h_f$

* The neutral axis is then located for the resulting beam and its moment of inertia (I_b) is calculated exactly.

* For normal proportions, I_b is approximately equal to twice the moment of inertia of rectangular portion for interior beams and 1.5 times the moment of inertia of rectangular portion for edge beam.

* The values may optionally be tabulated as in Table 12.2.

Table 12.2. Calculation of Stiffness of Beams.

Frame	Exterior Long	Interior Long	Exterior Short	Interior Short
Web width, b_w (mm)				
Depth, h (mm)				
I_b ($\times 10^4$ mm ⁴)				

α_f -Value And 6th Limitation Of DDM

α_f = ratio of flexural stiffness of beam section to flexural stiffness of a width of slab bounded laterally by centerlines of adjacent panels (if any) on each side of the beam. In other words, the width of slab should be equal to width of each design strip.

$$\alpha_f = \frac{\text{Beam stiffness}}{\text{Slab stiffness}} = \frac{E_{cb} I_b}{E_{cs} I_s}$$

$\alpha_{f1} = \alpha_f$ - value in direction of ℓ_1 :

$\alpha_{f2} = \alpha_f$ - value in direction of ℓ_2

$\ell_s =$ value of slab inertia effective for ℓ_1 direction.

$$= \frac{\ell_{2w} \times h^3}{12}$$

The 6th condition for the use of direct design method is that “The ratio of $\alpha_{f1} \ell_2 / \ell_1$ and $\alpha_{f2} \ell_1 / \ell_2$ must be between 0.2 to 5.0 for all combinations of beams in the perpendicular directions. This condition needs only to be satisfied if beams are present on all the four sides of the panel”.

Table 12.3. Calculation of Relative Stiffness of Beams.

Frame	Exterior Long	Interior Long	Exterior Short	Interior Short
$I_b (\times 10^4 \text{ mm}^4)$				
$\ell_{2w} (\text{mm})$				
$I_s (\times 10^4 \text{ mm}^4)$				
α_f				

Torsional Stiffness Of Edge Beam

The torsional members are considered to have a constant cross section throughout their length consisting of *the largest of*:

1. A portion of slab having a width equal to that of the column, bracket, or capital in the direction of the span for which moments are being determined

2. For monolithic or fully composite construction, the transverse beam above and below the slab is added to the portion of slab as above in (a) to get the effective slab width

3. The transverse beam as defined in Step 3 (ACI 13.2.4)

Divide the torsional members obtained into rectangles with smaller dimensions 'x' and larger dimension 'y', as shown in Fig. 12.14. The torsional constant is then evaluated as the following summation:

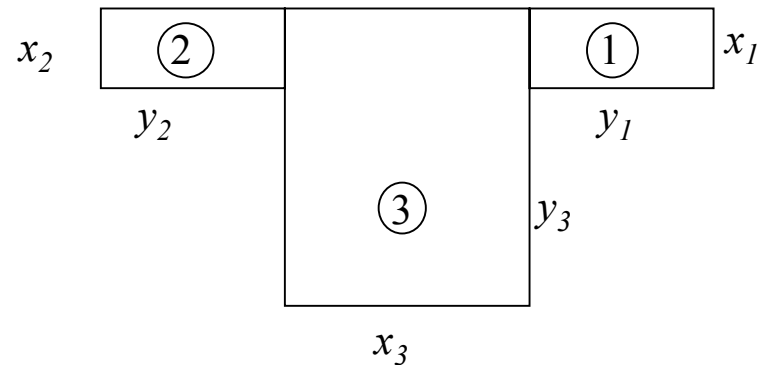

Fig. 12.14. Torsion Member.

$$C = \sum \left(1 - 0.63 \frac{x}{y} \right) \frac{x^3 \cdot y}{3}$$

Compute the torsional constant, C , for all the edge beams. These torsional constants are to be used for the perpendicular strips.

Calculation Of Factor β_t

The factor β_t is defined as the ratio of torsional stiffness of edge beam section to flexural stiffness of a width of slab equal to span length of the edge beams, center-to-center of supports.

$$\beta_t = \frac{GC \text{ of edge beam}}{EI \text{ of slab having width equal to span of edge beam}}$$

$$\cong \frac{E_{cb} C}{2E_{cs} I_s}$$

where $G = \frac{E}{2(1+\nu)} \cong \frac{E_{cb}}{2}$

if the Poisson's effect is neglected.

The calculation is same for exterior and interior frames as the width of slab is to be considered equal to the span of the torsion member. The systematic form of these calculations may be done by filling tables like Table 12.4.

Table 12.4. Torsion Properties of Beams.

Frame	Long	Short
Span of edge beam	Shorter	Longer
$C (\times 10^4 \text{ mm})$		
Span of torsion member, ℓ_2 (mm)		
$I_s (\times 10^4 \text{ mm})$ for ℓ_2 width		
β_t		

STEP 6: Calculation Of Factored Static Moment For Each Design Strip

The slab is divided into design strips and the total factored static moment is calculated for each design strip.

Absolute sum of positive and average negative factored moments, called total static moment, in each direction is equal to the following:

$$M_o = \frac{q_u \ell_{2w} \ell_n^2}{8}$$

where, ℓ_{2w} = total width of the design strip,

l_n = clear span, extending from face to face of columns, capitals, brackets, or walls.
 $\geq 0.65 l_1$

Circular or regular polygon shaped supports may be treated as square supports with the same area, as in Fig. 12.15.

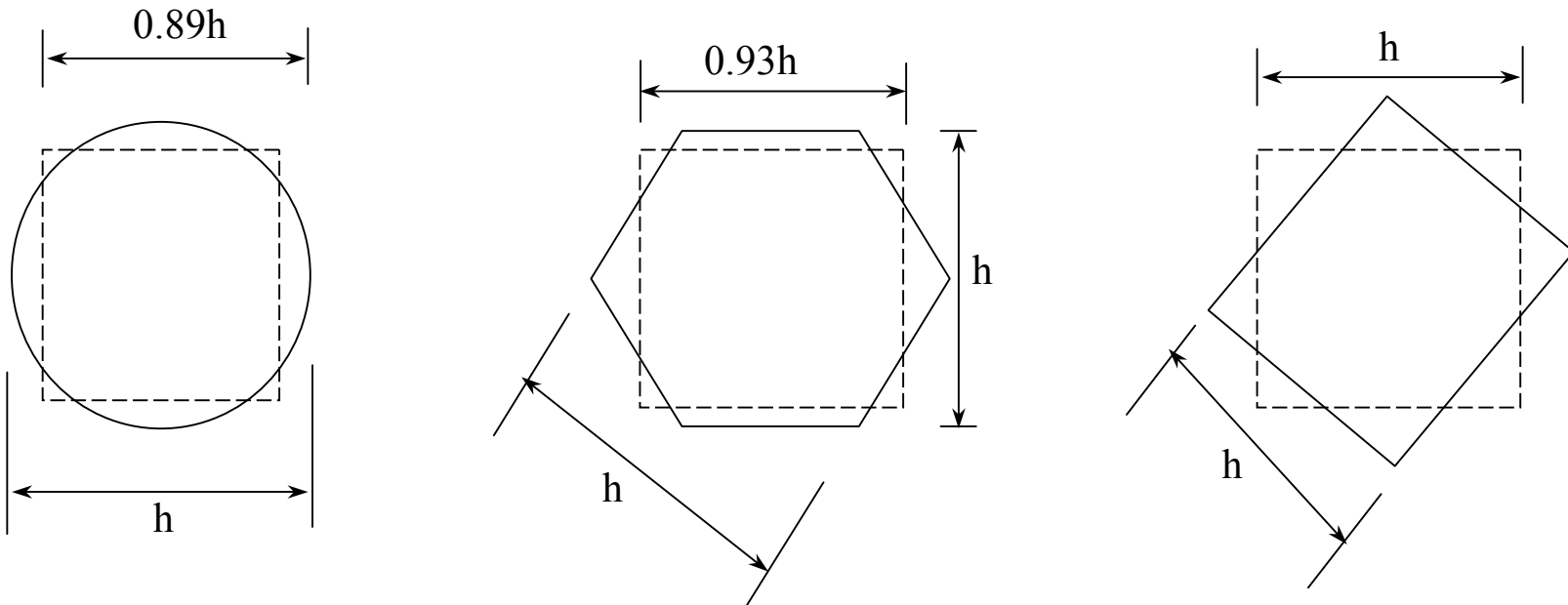

Fig. 12.15. Equivalent Column Area for Calculation of Clear Span.

ACI requires that where the transverse span of panels on either side of the centerline of supports varies, ℓ_{2w} in above equation is to be taken as the average of adjacent transverse spans.

Similarly, for the edge design frame, when the span adjacent and parallel to an edge is being considered, the distance from edge to panel centerline is substituted for ℓ_{2w} (ACI 13.6.2.4).

The values are entered in Table 12.5.

Table 12.5. Total Static Moments All Design Frames.

Frame	Exterior Long	Interior Long	Exterior Short	Interior Short
l_{2w} (m)				
l_n (m)				
M_o (kN-m)				

Step 7: Longitudinal Distribution Of Moments

Longitudinal distribution of moments means the way in which the total static moment at mid-span is divided into positive and negative moments.

According to ACI 13.6.3.2, in an interior span, total static moment M_o is to be distributed as follows:

$$\begin{aligned} \text{Factored } M^- \text{ at supports} &= 0.65 M_o \\ \text{Factored } M^+ \text{ at mid-span} &= 0.35 M_o \end{aligned}$$

ACI 13.6.3.3 says that, in an end span, M_o is to be distributed according to Table 12.6.

Table 12.6. Longitudinal Distribution of Moments For Exterior Slab Panels.

	Exterior edge unrestrained (Torsion member not considered)	Slab with beams between all supports	Slab without beams between interior supports		Exterior edge fully restrained
			Part of slab considered as torsion member	With edge beam	
	(1)	(2)	(3)	(4)	(5)
Int. M^-	0.75	0.70	0.70	0.70	0.65
M^+	0.63	0.57	0.52	0.50	0.35
Ext. M^-	0	0.16	0.26	0.30	0.65

Table 12.7. Moments After Longitudinal Distribution.

Frame	Exterior Long	Interior Long	Exterior Short	Interior Short
M_o				
M^- at ext. support				
M^+ in ext. span				
M^- at first int. support				
M^- at typical int. support				
M^+ in interior span				

Step 8: Transverse Distribution Of Moments

The moments determined at critical sections of the design frames as above are further distributed into column strips including the beams (if any) and middle strips.

This step is called the transverse distribution of moments.

Column Strip Moment Percentages

Let

$$\ell_2/\ell_1 = A \quad 0.5 \leq A \leq 2.0$$

$$\beta_t = B \quad \text{If } \beta_t > 2.5, B = 2.5$$

$$\alpha_{f1} \frac{\ell_2}{\ell_1} = D \quad \text{If } \alpha_{f1} \frac{\ell_2}{\ell_1} > 1.0, D = 1.0$$

As per ACI 13.6.4, column-strip moment is expressed as the following percentage of total moment at critical section:

Interior negative moment (%age):	$75 + 30(1-A)D$
Exterior negative moment (%age):	$100 - 10B$ $+ 2BD(1 - A)$
Positive moment (%age):	$60 + 15(3 - 2A)D$

Beam Moment

$$\alpha_{f1} \frac{\ell_2}{\ell_1} \times 85 \quad \text{with a maximum of 85 \%}$$

Column Strip Slab Moment

$$\text{CS slab moment} = \text{CS moment} - \text{beam moment}$$

Table 12.8. Column Strip And Beam Moments.

Frame	Ext. Long	Int. Long	Ext. Short	Int. Short
$A = l_2/l_1$				
$B = \beta_t$				
$D = \alpha_{fl} l_2/l_1$				
%age of M^+ to column strip				
%age share of beam from above moment				
%age of $M^+_{int.}$ to column strip				
%age share of beam from above moment				
%age of $M^+_{ext.}$ to column strip				
%age share of beam from above moment				

Middle Strip Moments

The portion of the total moment at critical sections of design frames not resisted by the column strip is proportionally assigned to the adjacent half middle strips (ACI 13.6.6).

The middle strip adjacent to *an edge supported by a wall* should be proportioned to resist twice the moment assigned to its interior half.

The resulting values may be entered in Table 12.9, for all of the critical sections.

Table 12.9. Design Bending Moments For Various Frames.

Frame	Location	Ext. Long	Int. Long	Ext. Short	Int. Short
Beam moment	M^-_{ext}				
	$M^+_{\text{ext span}}$				
	$M^-_{\text{first int}}$				
	$M^-_{\text{first int}}$				
	$M^+_{\text{int span}}$				
Column strip slab moment	M^-_{ext}				
	$M^+_{\text{ext span}}$				
	$M^-_{\text{first int}}$				
	M^-_{int}				
	$M^+_{\text{int span}}$				
Middle strip moment	M^-_{ext}				
	$M^+_{\text{ext span}}$				
	$M^-_{\text{first int}}$				
	M^-_{int}				
	$M^+_{\text{int span}}$				

STEP 9: Calculation Of Slab Reinforcement

The slab steel may be calculated from the slab moments by using the usual under-reinforced concrete design formulas.

Table 12.11. Slab Steel Areas For Various Frames.

Frame	Location	Ext. Long	Int. Long	Ext. Short	Int. Short
CS Width Minus Beam Width					
A_s for column strip	M^-_{ext}				
Dia. and no. of bars for CS					
A_s for column strip	$M^+_{\text{ext span}}$				
Dia. and no. of bars for CS					
A_s for column strip	$M^-_{\text{first int}}$				
Dia. and no. of bars for CS					
A_s for column strip	M^-_{int}				
Dia. and no. of bars for CS					
A_s for column strip	$M^+_{\text{int span}}$				
Dia. and no. of bars for CS					

MS Width					
A_s for column strip	M^-_{ext}				
Dia. and no. of bars for MS					
A_s for column strip	$M^+_{\text{ext span}}$				
Dia. and no. of bars for MS					
A_s for column strip	$M^-_{\text{first int}}$				
Dia. and no. of bars for MS					
A_s for column strip	M^-_{int}				
Dia. and no. of bars for MS					
A_s for column strip	$M^+_{\text{int span}}$				
Dia. and no. of bars for MS					

STEP 10: Development Of Flexural Reinforcement

For slabs with beams, usual procedure is used to curtail the slab reinforcement.

However, for slabs without beams, ACI Fig. 13.3.8 is used for detailing that gives the following provisions for bar curtailment in slabs without beams:

A. Column Strip Top Steel

Half top steel should extend $0.30\ell_n$ beyond the face of support and 90° hooks are to be provided at ends in exterior supports. This should be increased to $0.33\ell_n$, if drop panels are present.

The remainder half steel should extend $0.20 \ell_n$ past the face of support and must end with 90° hooks in exterior supports.

B. Column Strip Bottom Steel

All bars must be provided throughout the span, with half having 90° hooks in exterior supports over the columns.

C. Middle Strip Top Steel

All bars must extend $0.22 \ell_n$ past the face of support, with 90° hooks in exterior supports.

D. Middle Strip Bottom Steel

Half bottom steel should extend throughout the span.

The remainder half alternate bars should extend fully to the outer edges but can be curtailed at a maximum distance of $0.15 \ell_n$ from center of the interior supports.

STEP 11: Shear In Beams

According to ACI 13.6.8, for beams with $\alpha_{f1}(\ell_2/\ell_1) \geq 1.0$, shear is calculated by 45° tributary lines area shown in Fig. 12.16. For $\alpha_{f1}(\ell_2/\ell_1) < 1.0$, linear interpolation should be made assuming that shear is zero when $\alpha_{f1} = 0$.

Area Supported By Beam CD

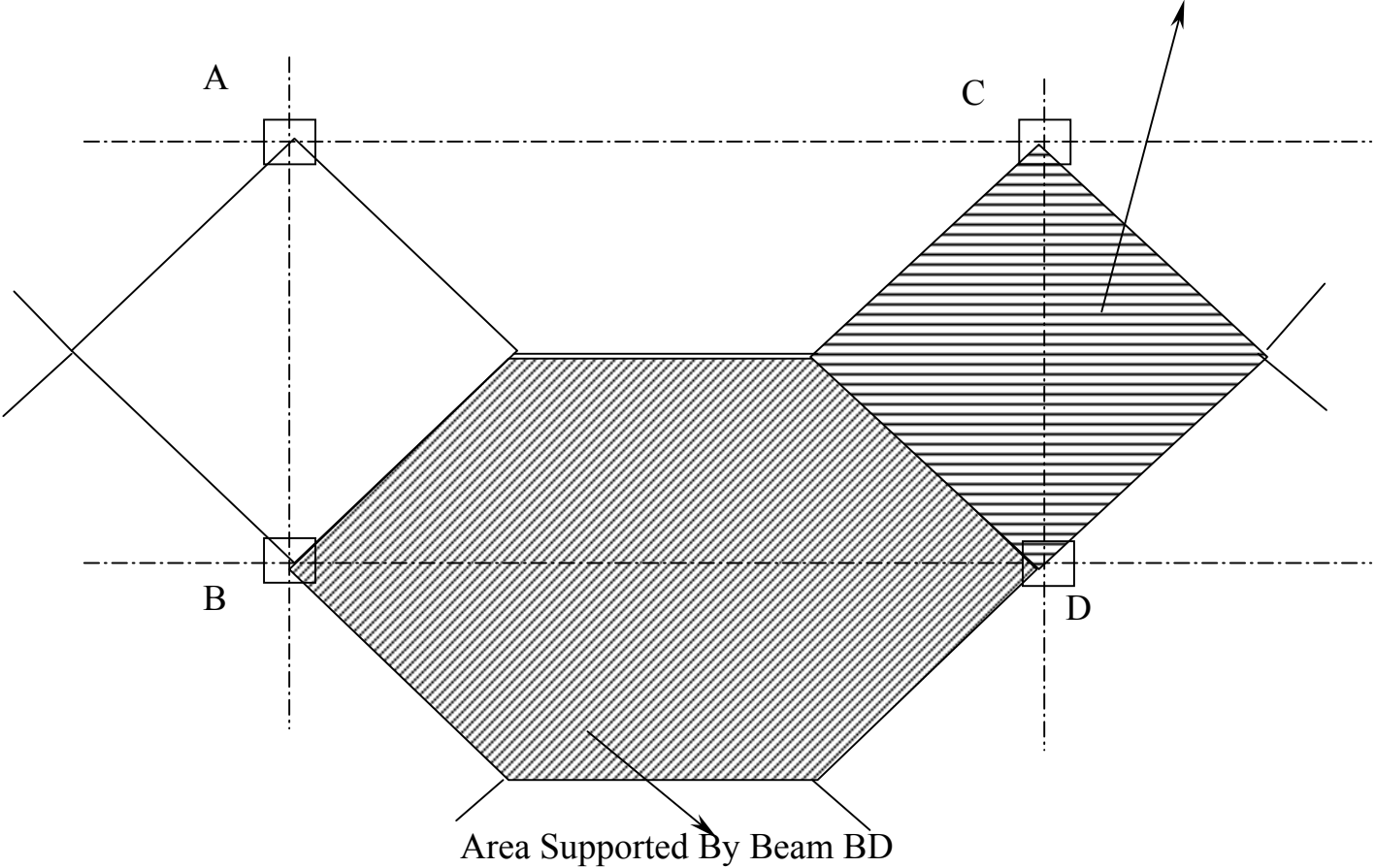

Fig. 12.16. Slab Tributary Areas For Beam Shears.

STEP 12: Beam Design

Design the beams, if present, both for flexure and shear.

STEP 13: Column Design Moments

Interior Column: As per ACI clause 13.6.9.2, at an interior support, supporting elements (columns) above and below the slab must resist the bending moment given below in direct proportion to their stiffness.

$$M = 0.07 [(q_{DU} + 0.5 q_{LU}) \ell_2 \ell_n^2 - q'_{DU} \ell'_2 (\ell'_n)^2]$$

Where q'_{DU} , ℓ'_2 and ℓ'_n are dead load, panel width and clear span related to shorter span.

Edge Column: As already stated, according to ACI 13.6.3.6, the gravity load moment to be transferred between slab and edge column is to be $0.3 M_o$.

STEP 14: Moment Transferred From Slab To Column By Flexure (ACI 13.5.3)

Two-Way Shear Or Punching Shear: The shear acting all along the perimeter of a column for a flat slab without beams can punch the column into the slab and is called two-way or punching shear.

Direct Shear: The two-way shear produced by the vertical loads on the slab and having constant stress intensity all along the critical perimeter is called direct shear.

Concept Of Eccentric Shear Or Combined Shear And Moment:

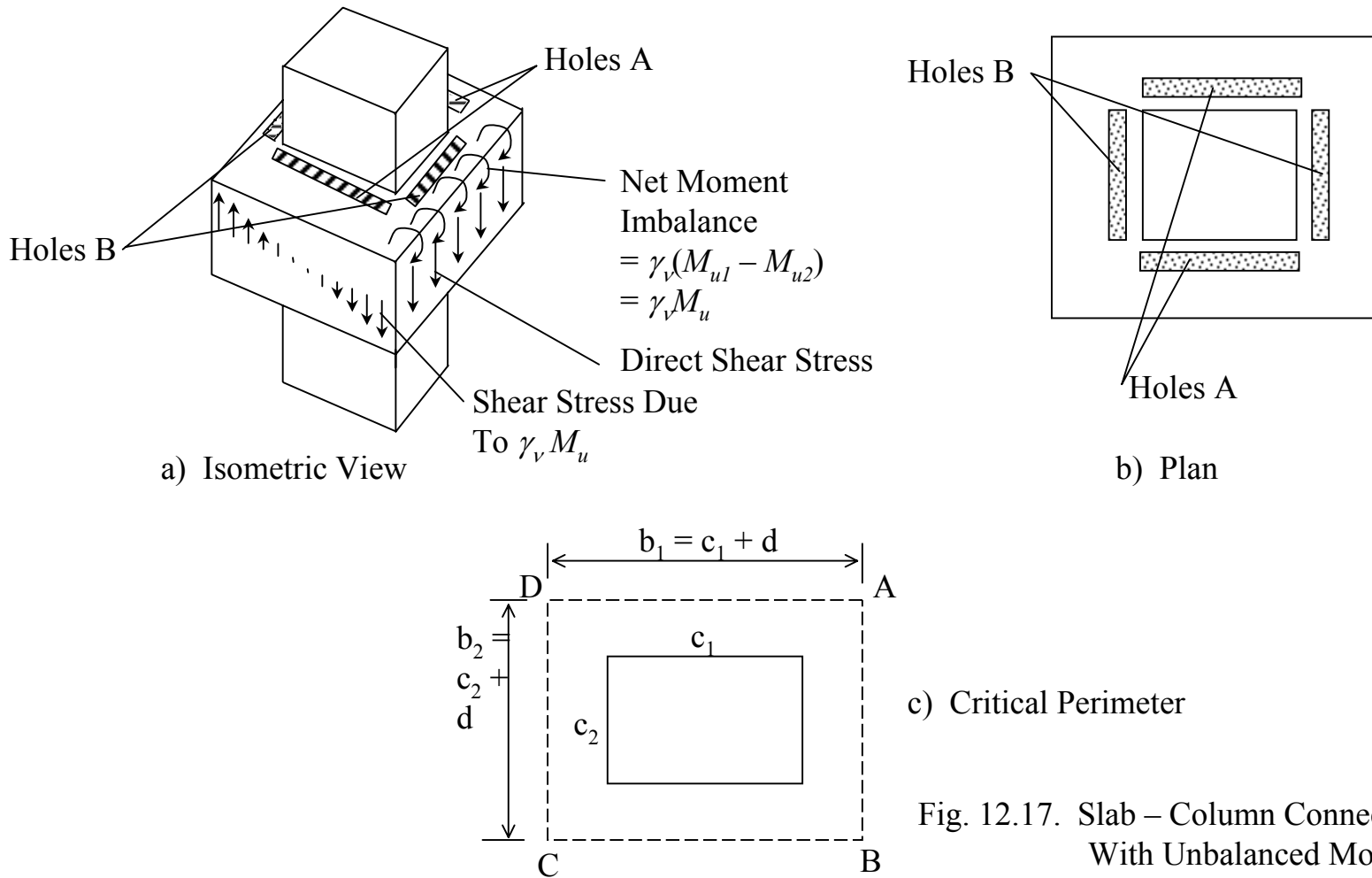

Fig. 12.17. Slab – Column Connection With Unbalanced Moment.

When any load cause transfer of unbalanced moment M_u between a slab and a column, a min. fraction of the unbalanced moment between slab and column, $\gamma_f M_u$, must be transferred by flexure within ***an effective slab width between lines that are $1.5h$ (h is the slab or drop panel thickness) outside opposite faces of the column or capital.***

Concentration of reinforcement over the column by closer spacing or additional reinforcement is to be used to resist moment on the effective slab width defined above. However, the reinforcement ratio ρ within the effective slab width should not exceed $0.375 \rho_b$.

STEP 15: Moment Transferred From Slab To Columns By Eccentric Shear

Moment Transferred By Eccentric Shear:

As stated above, after the transfer of moment $\gamma_f M_u$ by flexure, the remainder of the unbalanced moment $\gamma_v M_u$ is transferred by eccentricity of shear about the centroid of the critical section.

$$\gamma_v = 1 - \gamma_f$$

Critical section: The edges of critical section perimeter for punching shear as defined in ACI 11.12.1.2 are considered at distance $d/2$ from the following:

Edges or corners of columns, concentrated loads,
or reaction areas, or

Changes in slab thickness such as edges of capital
or drop panels.

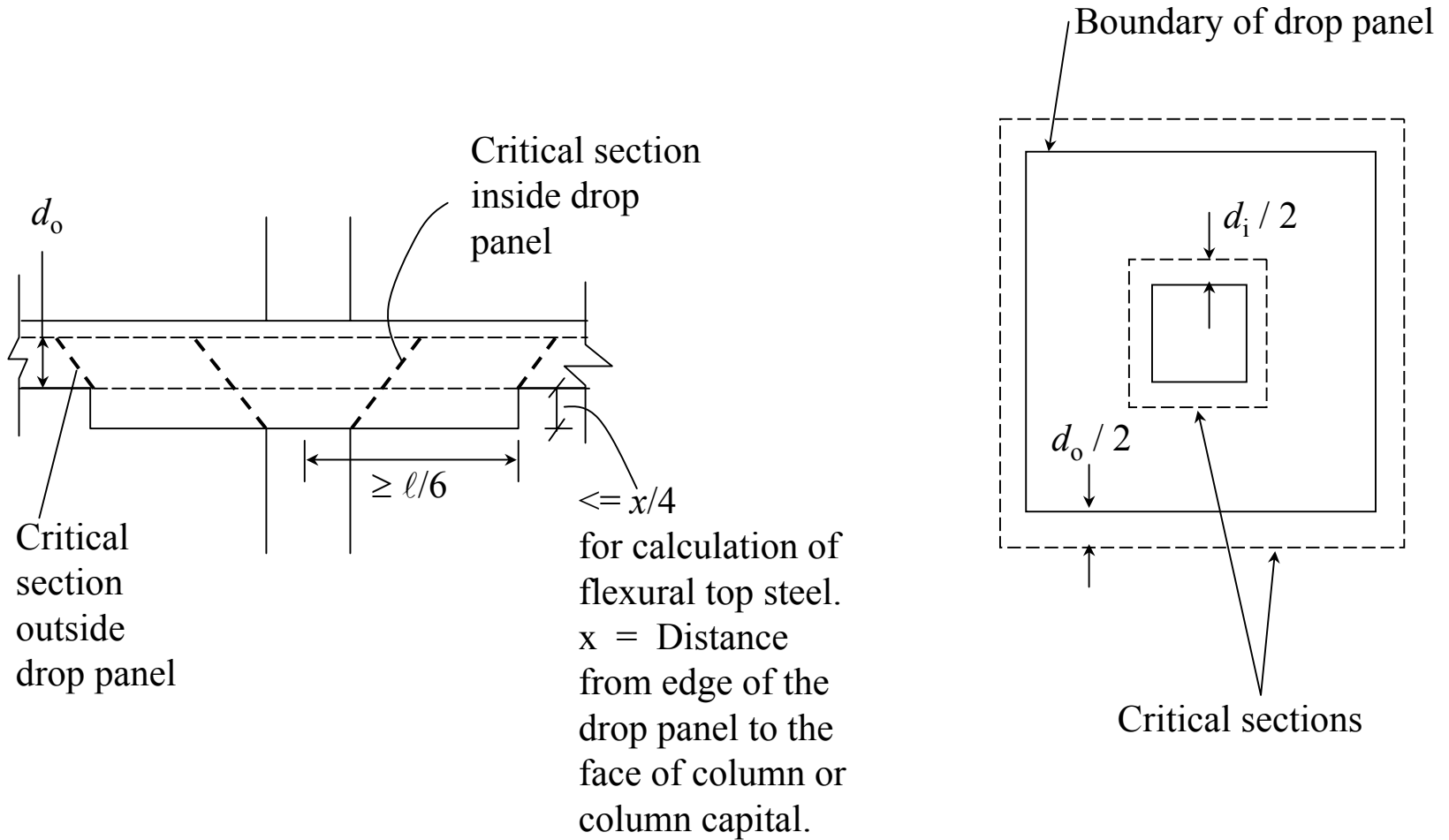

$d_o =$ effective depth outside the drop panel
 $d_i =$ effective depth inside the drop panel

Figure 12.18. Critical Shear Section.

$$\gamma_f = \frac{1}{1 + \frac{2}{3} \sqrt{\frac{b_1}{b_2}}}$$

b_1 = width of the critical section for punching shear defined in the direction of the span for which moments are determined, mm.

b_2 = same in a direction perpendicular to b_1 .

$$\gamma_v = 1 - \frac{1}{1 + \frac{2}{3} \sqrt{\frac{b_1}{b_2}}}$$

For unbalanced moments about an axis parallel to the edge at exterior supports, the value of γ_f may be increased up to 1.0 provided that the following conditions are satisfied:

V_u at an edge support	$0.75 \phi V_c$
or V_u at an corner support	$0.5 \phi V_c$

For unbalanced moments, about an axis transverse to the edge at exterior supports, the value of γ_f is allowed to be increased by up to 25% provided that the following requirement is satisfied:

V_u at the support	$0.4 \phi V_c$
----------------------	----------------