

## Special Moment frames (Section 21.5, ACI-2008) (Flexural members- General Requirements)

1. If factored axial compressive force  $P_u < A_g f_c' / 10$ , then the member is considered to be subjected to bending.  $A_g$  represent the gross area of the concrete member. Flexural member should satisfy following the conditions
  - a. Clear span  $L_n \geq 4 \times$  effective depth “d”
  - b. The flexural member width to depth ratio,  $b_w / d \geq 0.3$ .
  - c. Flexural member width  $b_w \geq 10$  inch

## Special Moment frames (Section 21.5, ACI-2008) (Flexural members- General requirements)

d. Flexural member width  $b_w$ , shall not exceed width of supporting member,  $c_2$ , plus a distance on each side of the supporting member equal to the small of (i) and (ii).

- (i) Width of the supporting member,  $c_2$ , and
- (ii) 0.75 times the overall dimension of supporting member,  $c_1$ .

# Special Moment frames (Section 21.5, ACI-2008) (Flexural members-General requirements)

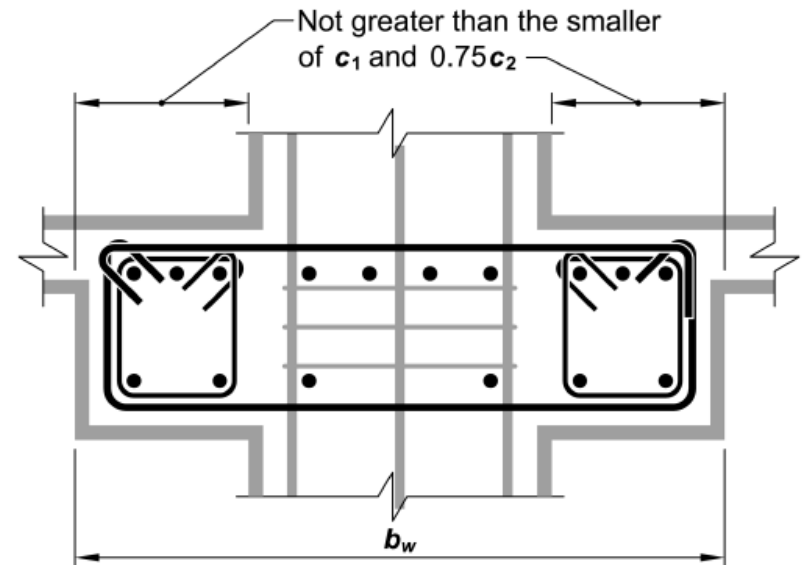
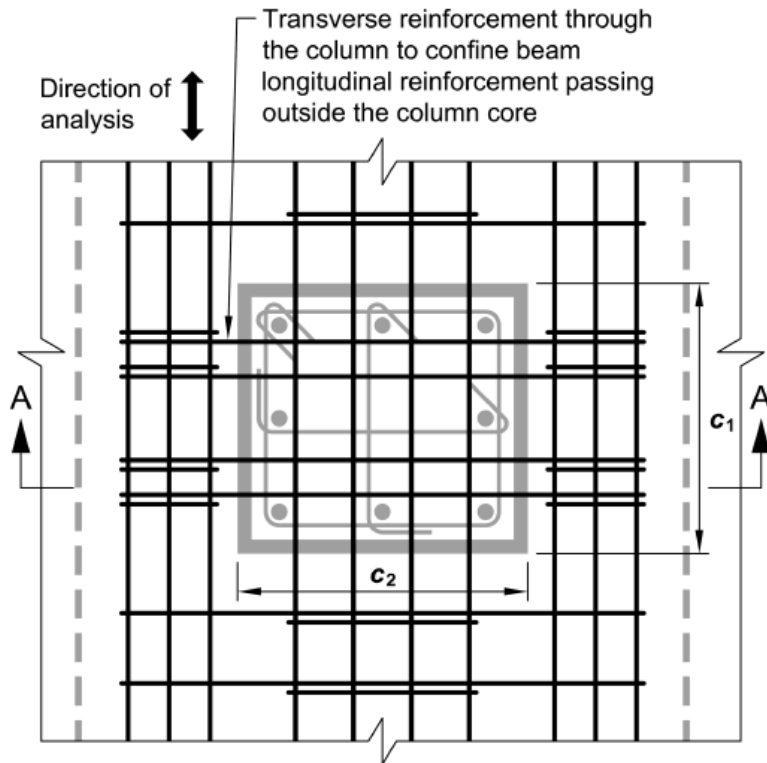

Note:  
Transverse reinforcement in column above and below the joint not shown for clarity

SECTION A-A

## Special Moment frames (Section 21.5, ACI-2008) (Flexural members- Longitudinal reinf. requirements)

According to ACI-08 Section,21.5.2, the longitudinal reinf. Shall satisfy the following.

1. Longitudinal reinforcement for both top and bottom steel ( $A_s$ ) should be in the range defined as follows:

$$\left. \begin{array}{l} \frac{3\sqrt{f'_c}bd}{f_y} \\ \frac{200bd}{f_y} \end{array} \right\} \leq (A_s) \leq 0.025bd$$

At least two bars should be provided continuously at both top and bottom. For the statically determined T-sections with flanges in tension the value of  $b$  in the expression  $3\sqrt{f'_c}bd/f_y$  should be replaced by either  $2b$  (width of web) or the width of the flange, whichever is smaller (ACI 2008, Section 10.5.2).

# Special Moment frames (Section 21.5, ACI-2008) (Flexural members- Longitudinal reinf. requirements)

2. The positive moment strength at joint face should be greater or equal  $\frac{1}{2}$  negative moment strength at that face of the joint (ACI Section 21.5.2.2):

$$\phi M_{n_l}^+ \geq \frac{1}{2} \phi M_{n_l}^- \quad (\text{left joint})$$

$$\phi M_{n_r}^+ \geq \frac{1}{2} \phi M_{n_r}^- \quad (\text{right joint})$$

where

$M_{n_l}$  = moment strength at left joint of flexural member

$M_{n_r}$  = moment strength at right joint of flexural member

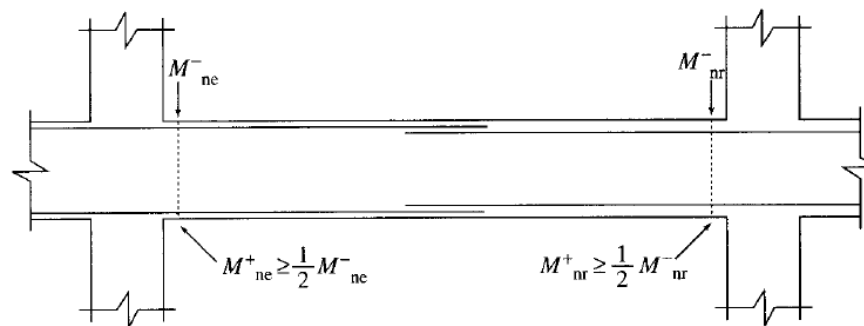

Longitudinal reinforcement requirements.

## Special Moment frames (Section 21.5, ACI-2008) (Flexural members- Longitudinal reinf. requirements)

3. Neither the negative nor positive moment strength at any section along the member should be less than  $\frac{1}{4}$  the maximum moment strength provided at the face of either joint.

$$(\phi M_n^+ \text{ or } \phi M_n^-) \geq \frac{1}{4} (\max \phi M_n \text{ at either joint})$$

4. Anchorage of flexural reinforcement in support can be calculated using the following equation:

$$l_{dh} \geq \begin{cases} \frac{f_y d_b}{65 \sqrt{f'_c}} \\ 8d_b \\ 6 \text{ in.} \end{cases}$$

where  $d_b$  is the diameter of longitudinal reinforcement.

## Special Moment frames (Section 21.5, ACI-2008) (Flexural members- Longitudinal reinf. requirements)

5. Lap splices of flexural reinforcement are permitted only if hoop or spiral reinforcement is provided over the lap length. Hoop or spiral reinforcement spacing should not exceed  $d/4$  or 4 in., whichever is smaller. Lap splices should not be used within a joint, within a distance of twice the member depth from the face of the joint, or at locations of plastic hinges.

## Special Moment frames (Section 21.5, ACI-2008) (Flexural members- Transvers reinf. requirements)

For the special moment resisting frames, plastic hinges will form at the ends of flexural members. Those locations should be specially detailed to ensure sufficient ductility of the frame members. Transverse reinforcement gives lateral support for the longitudinal reinforcement and assists concrete to resist shear . It should satisfy the following.



## Special Moment frames (Section 21.5, ACI-2008) (Flexural members- Transvers reinf. requirements)

1. Hoops are required over a length equal to twice the member depth from the face of the support at both ends of flexural member. Also, hoops are required over lengths equal to twice the member depth on both sides of section where flexural yielding may occur, as shown in Fig. 20.12.

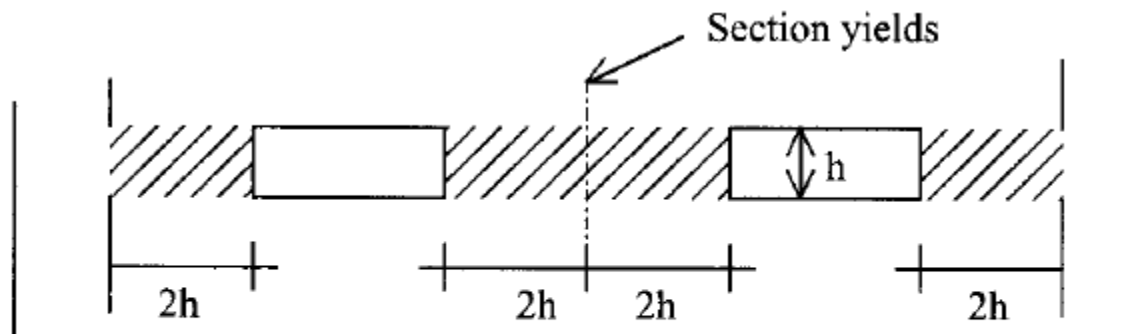
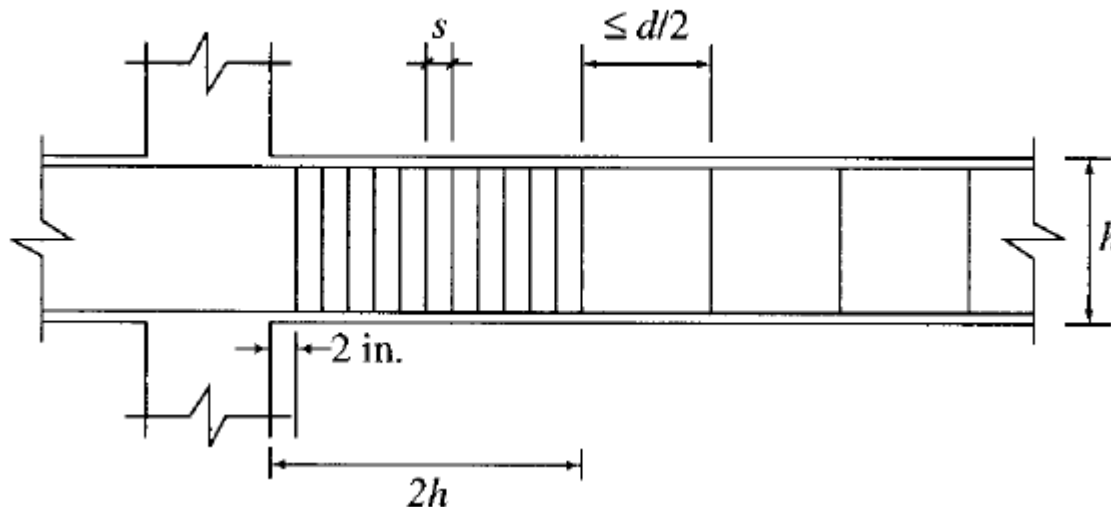

**Figure 20.12** Areas of the flexural member where hoops are required. (Note: These areas do not necessarily occur at midspan.)

## Special Moment frames (Section 21.5, ACI-2008) (Flexural members- Transvers reinf. requirements)

2. The spacing of the hoops,  $s$ , should not exceed the smallest of the following values:
- $d/4$
  - Eight times the diameter of the smallest longitudinal bar
  - 24 times the diameter of the hoop bars
  - 12 in.

The first hoop should be located not more than 2 in. from the face of the support.



# Special Moment frames (Section 21.5, ACI-2008) (Flexural members- Transvers reinf. requirements)

3. Where hoops are not required, stirrups with seismic hooks at both ends should be used. Spacing between stirrups should be less than or equal to  $d/2$ .

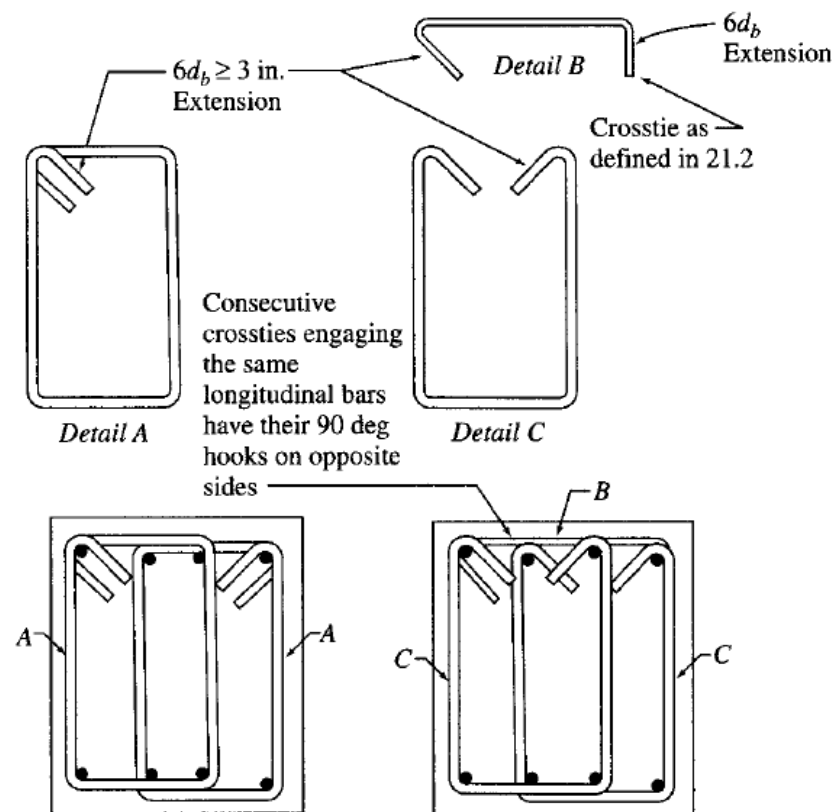

# Special Moment frames (Section 21.5, ACI-2008) (Flexural members- Transvers reinf. requirements)

4. Transverse reinforcement should be designed to resist the design shear force (Figs. 20.13 and 20.14). Design shear force for flexural members of special moment frames can be determined using the following equation (Fig. 20.15):

$$V_l = \frac{M_{pr}^- + M_{pr}^+}{l_n} + \frac{w_u l_n}{2} \quad (20.38a)$$

$$V_r = \frac{M_{pr}^+ + M_{pr}^-}{l_n} - \frac{w_u l_n}{2} \quad (20.38b)$$

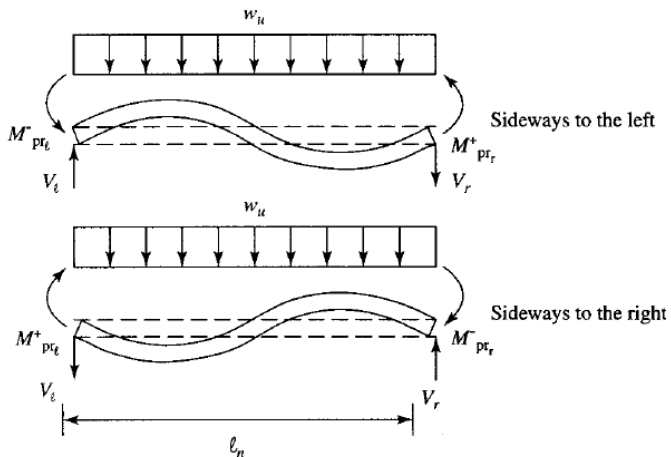

Figure 20.15 Design shear force.

## Special Moment frames (Section 21.5, ACI-2008) (Flexural members- Transvers reinf. requirements)

where

$V_l$  = design shear force at left joint of flexural member

$V_r$  = design shear force at right joint of flexural member

$M_{pr}$  = probable moment strength at the end of the beam determined as strength of the beam with the stress in the reinforcing steel equal to  $1.25 f_y$  and a strength reduction factor of  $\phi = 1.0$ .

$l_n$  = clear span of flexural member

$w_u$  = factored distributed load determined by Eq. 20.47

$$w_u = 1.2D + 1.0L + 0.2S \quad (20.39)$$

where

$D$  = dead load

$L$  = live load

$S$  = snow load

## Special Moment frames (Section 21.5, ACI-2008) (Flexural members- Transvers reinf. requirements)

Probable moment strength at the end of the beam,  $M_{pr}$ , can be calculated from the following equation:

$$M_{pr} = A_s(1.25 f_y) \left( d - \frac{a}{2} \right) \quad (20.40)$$

where

$$a = \frac{A_s(1.25 f_y)}{0.85 f'_c b} \quad (20.41)$$

The shear strength of concrete can be taken to be 0 when the earthquake-induced shear force is greater than or equal to 50% of the total shear force and the factored axial compressive force is less than  $A_g f'_c / 20$ , where  $A_g$  is the gross area of the beam.

## Special Moment frames (Example)

Design a beam AB on the second floor of a building. The building is constructed in the region of high seismic risk on soil class B.

The material properties are

Concrete  $f_c' = 4000\text{psi}$   $F_y = 60\text{ ksi}$   $LL = 40\text{psf}$

$DL-Sl = 35\text{psf}$

Beam size = 20x24inch

Column size = 24x 24 inch

Slab thickness = 7 inch