

# Module 5

## HYDROPOWER ENGINEERING

# LESSON

# 2

# HYDROPOWER WATER CONVEYANCE SYSTEM

As indicated in Lesson 5.1 a dam or diversion structure like a barrage obstructs the flow of a river and creates a potential head which is utilized by allowing the water to flow through the water conducting system upto the turbines driving the generators and then allowing it to discharge into the river downstream. Right from the intake of the water conducting system, where water enters from the main river, up to the outlet where water discharges off back into the river again, different structural arrangements are provided to fulfil certain objectives, the important ones being as follows:

1. The water inflowing into the conveyance system should be free from undesirable material, as far as possible, that may likely damage the turbines or the water conducting system itself.
2. The energy of the inflowing water may be preserved, as far as possible, throughout the water course so that the turbine-generator system may extract the maximum possible energy out of the flowing water.

As an example of the first case, it may be cited that in hilly rivers, there are good chances of sand, gravel, and even boulders getting into the water conducting system along with the flowing water. The bigger particles may choke the system whereas the smaller ones may erode the turbine blades by abrasive action. Apart from these, floating materials like trees or dead animals and in some projects in the higher altitudes ice blocks may get sucked into the system which may clog the turbine runners.

The main components of a water conveyance system consists of the following:

1. Intake structure
2. Water conducting system comprising of different structures
3. Outflow structure, which is usually a part of the turbine tail end

The water conducting system, again, may be of two types

1. Open channel flow system
2. Pressure flow system

In the pressure flow system, there could be further classification into the two types, as:

1. Low-pressure conduits and tunnels
2. High-pressure conduits, commonly called the penstocks

In either of the above cases, some provision is usually made to prevent the undesirable effects of a power rejection in the generator that may cause the turbine to spin exceedingly fast, resulting in a closure of the valves controlling the flow of water at the turbine end. If the closure is relatively fast, high pressures may develop in pressured systems conducting water to the turbine. For open channel systems, this may lead to generation of surges in the water surface which may even cause spillage of the channel banks if adequate freeboard is not provided.

This chapter discusses the important issues related to the different components of a hydropower Water Conveyance System.

## 5.2.1 Intakes

An intake is provided at the mouth of a water conveyance system for a hydropower project. It is designed such that the following points are complied, as far as possible:

1. There should be minimum head loss as water enters from the reservoir behind a dam or the pool behind a barrage into the water conducting system.
2. There should not be any formation of vortices that could draw air into the water conducting system.
3. There should be minimum entry of sediment into the water conducting system.
4. Floating material should not enter the water conducting system.

The position and location of an intake in a hydropower project would generally depend upon the type of hydropower development, that is, whether the project is of run-of-river type or storage type. For each one of these hydropower projects, there are a few different types, the important ones of which are explained in the following paragraphs.

### Run-of-river type intake

- Intakes adjacent to a diversion structure like a barrage. Here, an intake for a tunnel is placed upstream of the diversion structure to draw water from the pool (Figure 1). For a canal intake (Figure 2), the head regulator resembles that of an irrigation canal intake. It may be observed from Figure 3 that the canal conveying water, also called the power canal, leads to a Forebay before leading to the turbine unit. The exit passage from the turbines is called the Tail Race Channel. There is also a Bye-Pass Channel to release water when the turbines shut down suddenly.

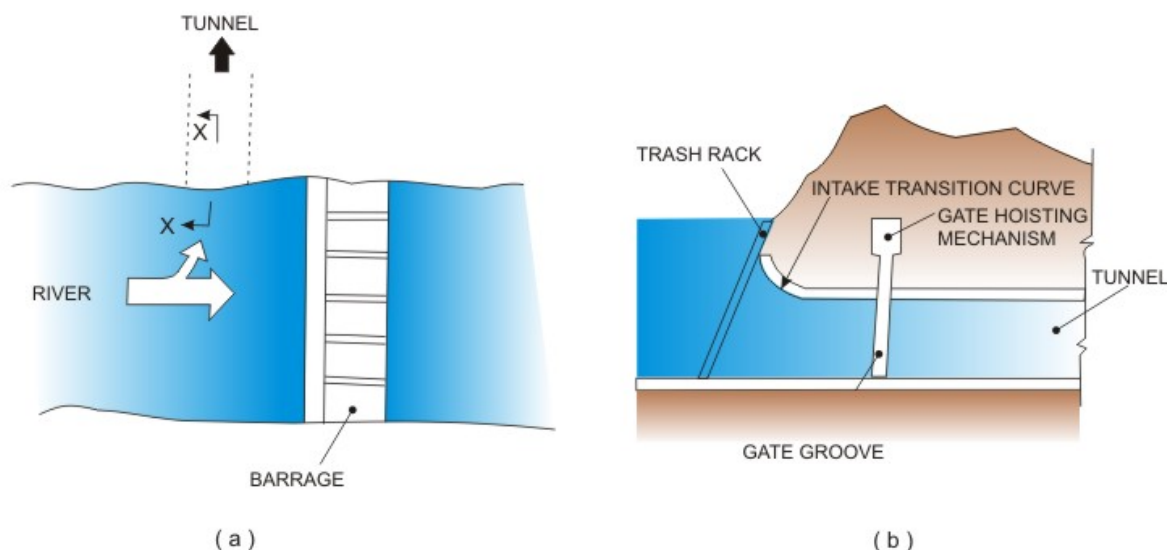

FIGURE 1. Intake adjacent to a barrage leading to a tunnel  
(a) Plan , (b) Section X-X

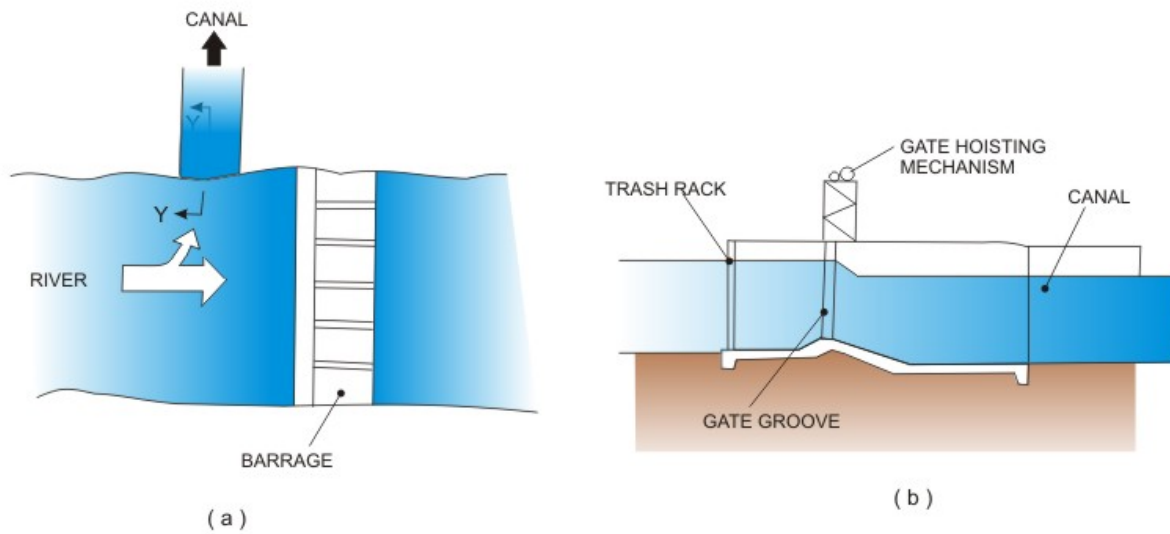

FIGURE 2. Intake adjacent to a barrage leading to a canal (a) Plan (b) Section through head regulator

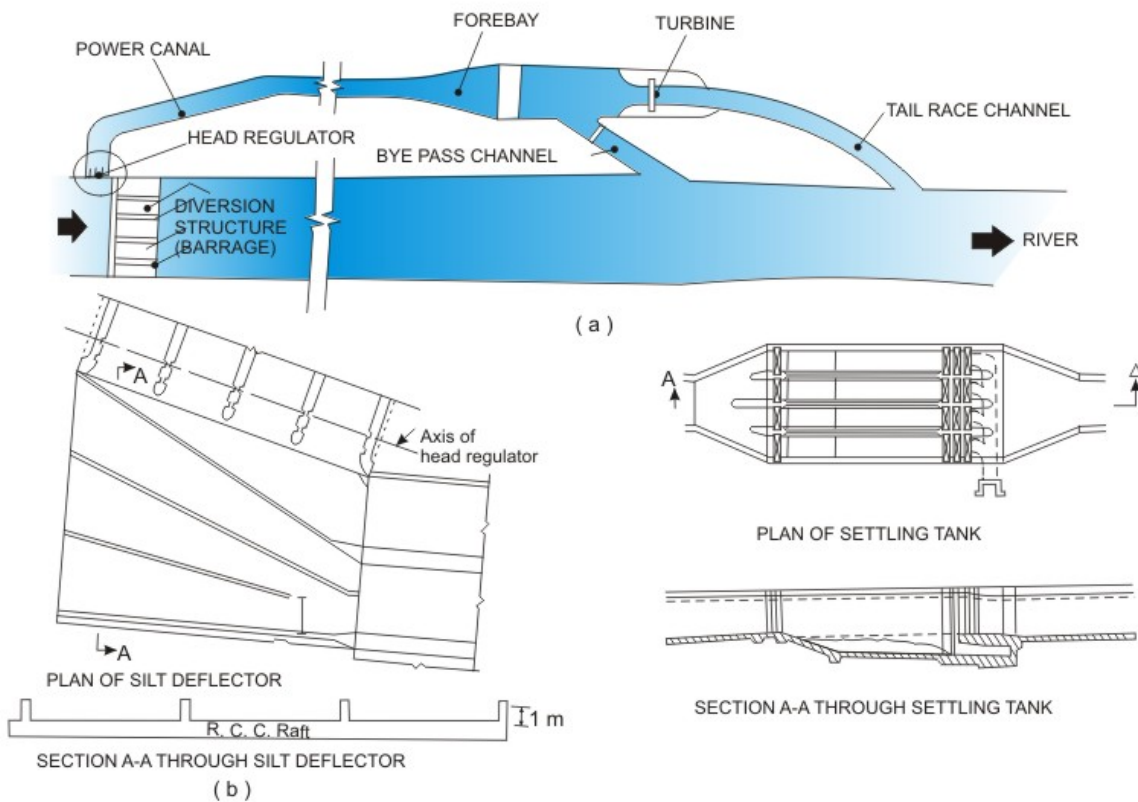

FIGURE 3. (a) Power canal leading to fore-bay at head of turbine unit, (b) Detail 'A' of head regulator for canals in hilly region equipped with silt deflector for preventing boulder entry & settling tank to remove sediment that too entered the canal.

- Intakes for in-stream power house. These are used for powerhouses located across rivers or canals to utilize the head difference across a canal drop. Here, the intake length is kept quite short and leads to either a vertical axis Kaplan turbine or a horizontal axis bulb turbine (Figure 4).

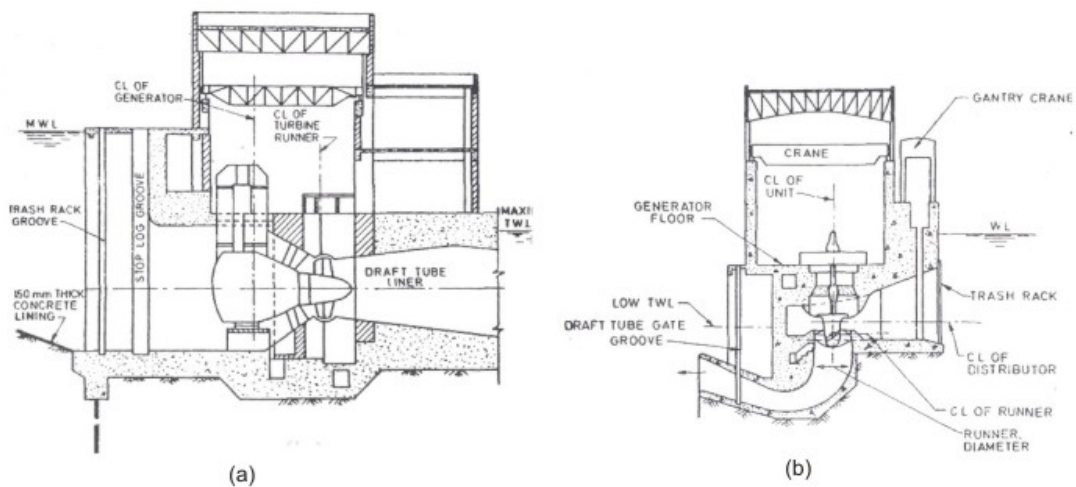

FIGURE 4. Intakes for river or canal fall power house integrated with turbine unit. (a) Kaplan turbines, (b) Bulb turbines.

### Reservoir type intakes

- Intakes for concrete dams are located on the upstream face of the dam as shown in Figure 5. The face of the intake is rectangular and is reduced to a smaller rectangular section through a transitory shape known as the bell-mouth. From the smaller rectangular section, another transition is provided to change the shape to circular.

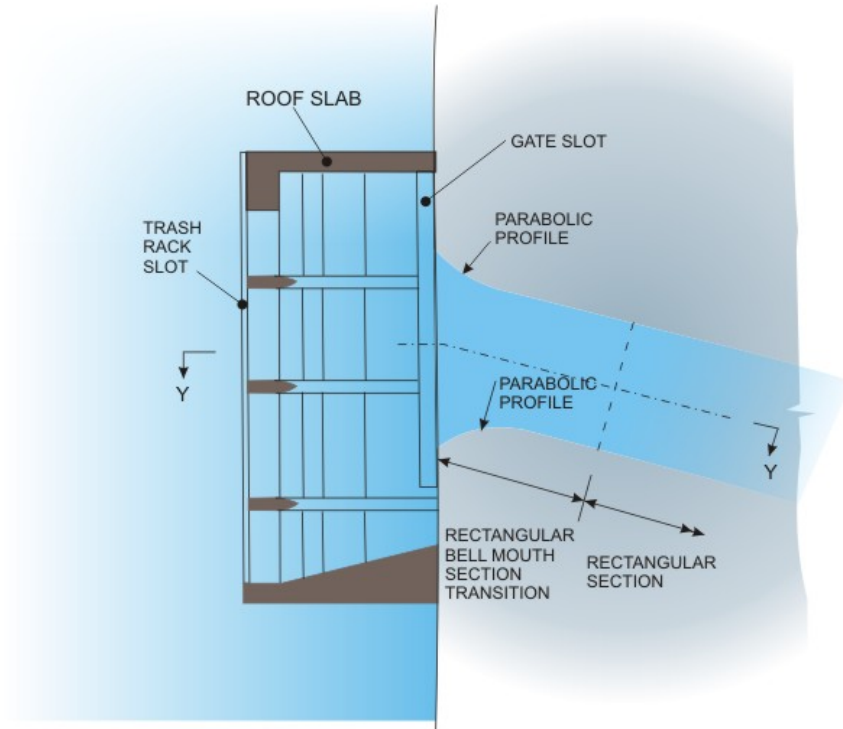

FIGURE 5. Intake from a reservoir upstream of a storage dam  
(a) Sectional elevation X - X.

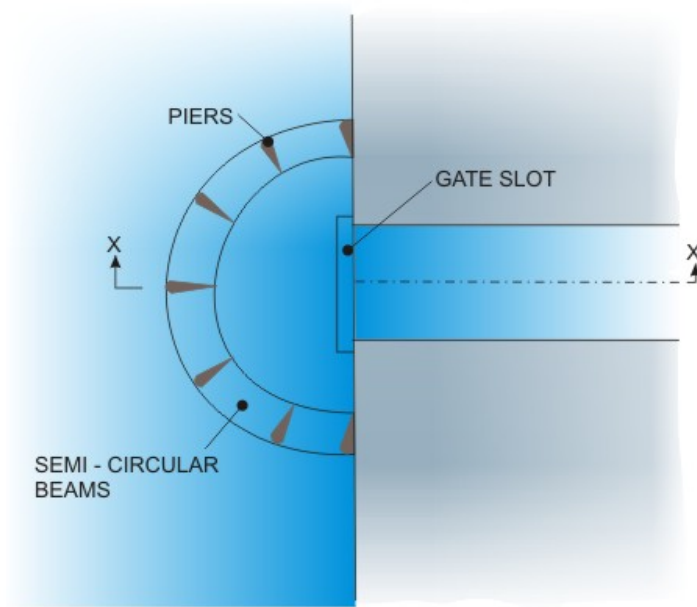
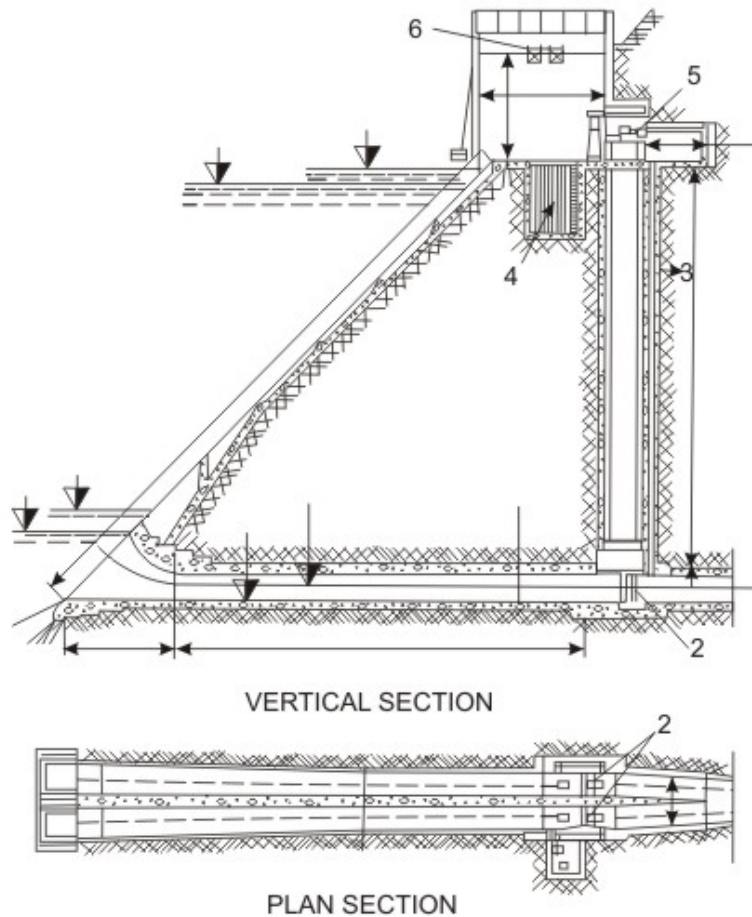

FIGURE 5. Intake from a reservoir upstream of a storage dam  
(b) Sectional plan Y - Y.

- Intakes for embankment dams are usually in the form of a conduit, which is laid below the dam and whose intake face is inclined (Figure 6) or are provided in the form of a tower (Figures 7 and 8). A tower type intake is constructed where there is a wide variation of the water level in the reservoir.



1 - Trashrack ; 2 - Membrane valve ; 3 - Aeration pipe ; 4 - Gate room ; 5 - Winch ; 6 - Crane

FIGURE 6. Sloping intake for an embankment dam



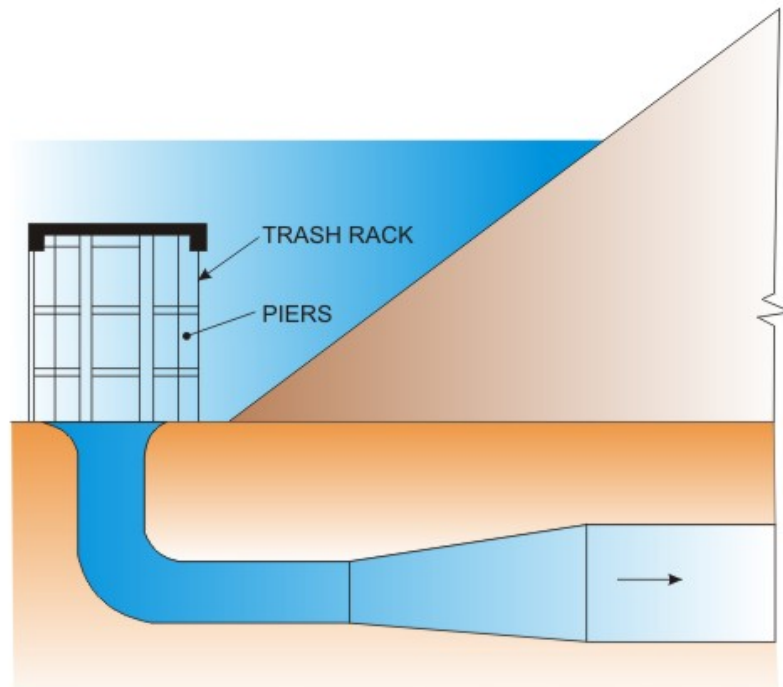

FIGURE 7. Tower type intake for an embankment dam with flow control by a vertical lift or radial gate in conduit

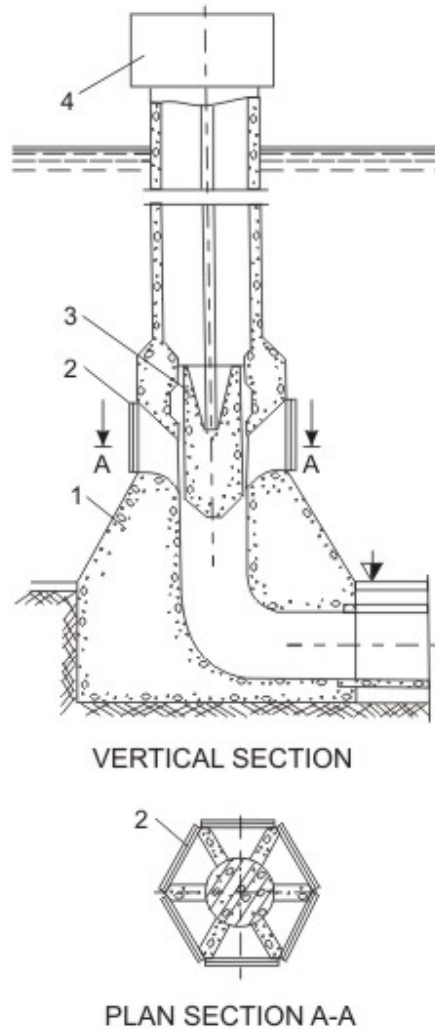

FIGURE 8. Tower type intake with cylindrical gate for flow control

- Intakes which have pressure tunnels off-taking from a storage reservoir and where the intake is located at a distance from the dam, say through the abutments, then the intake structure of such layout may be of inclined type or tower type as was provided in conjunction with the dam itself.

The choice and location of the intake structure depends upon the following factors.

- a) Type of development, that is, run-of-the-river or storage dam project;
- b) Location of power house vis-à-vis the dam ;
- c) Type of water conductor system, that is, tunnel, canal or penstock;
- d) Topographical features of area;
- e) In cases where there is a considerable movement of boulders, stones and sand in the downstream direction, the intake should be arranged so that the effect of such movement will not lead to a partial restriction or blockage of the intake. In respect of storage reservoir intakes the sill level of the intake should be aimed to be kept above the sedimentation level at or near the dam face arrived at; and

- f) The intake can often be located so as to enable it to be constructed before the level of the reservoir is raised.

Detail about the design of hydropower intakes may be obtained from the Bureau of Indian Standards code IS: 9761-1995 “Hydropower intakes-criteria for hydraulic design”.

In all the above intakes it may be noticed that a Trash Rack Structure is provided at the entry. A trash rack is actually a grill or a screen for preventing entry of suspended or floating material into the water conducting system. It is made usually of metallic strips welded in vertical and horizontal directions at regular spacings.

### 5.2.2 Water Conducting System

After flowing through the intake structure, the water must pass through the water conveyance system may be either of closed conduit type, as shown in Figure1 (tunnel off-taking from upstream of the river diversion) or could be open-channels as shown in Figure 2. High pressure intakes, for example as in the entry to penstocks (Figure 9) would be either reinforced concrete lined or steel lined. In this section we discuss the various types of water conducting passages.

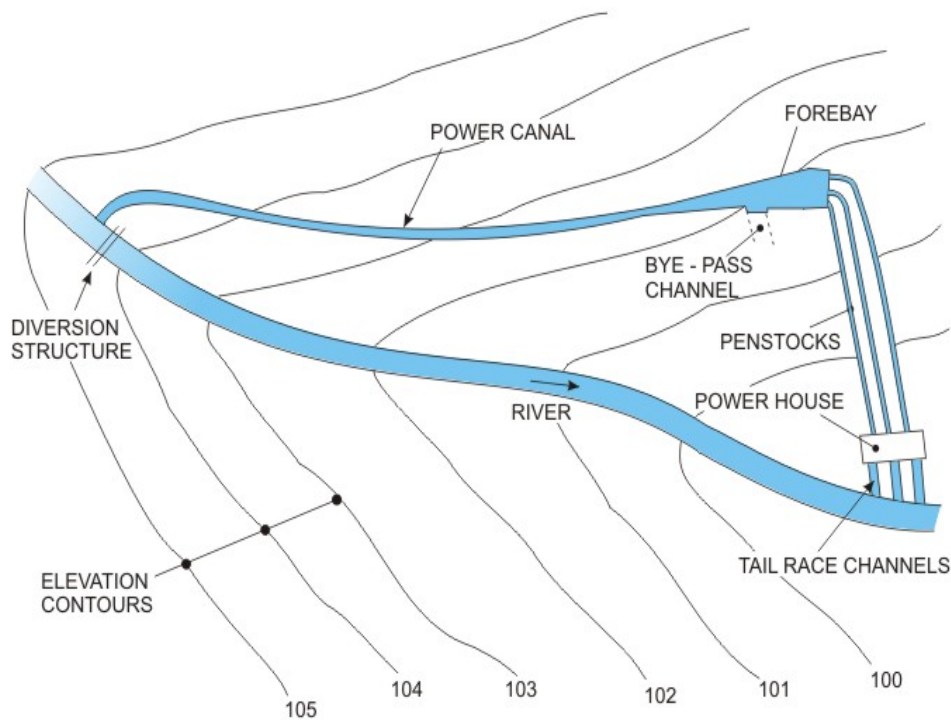

FIGURE 9. Alignment of a power canal along a hill slope

## Open channels

These are usually lined canals to reduce water loss through seepage as well as to minimize friction loss. The design of canals for hydropower water conveyance follows the same rules as for rigid bed irrigation channels, and are usually termed as power canals.

A power canal that offtakes from a diversion structure (Figure 2c) has to flow along the hill slope as may be observed from the alignment shown in Figure 9. A cross section of the canal would show that there would usually be high ground on one bank and falling ground on the other (Figure 10). It is important to stabilize the uphill cut-slope with some kind of protection in order to prevent fallout of loose blocks of stone into the canal. Some stretch of the canal could also be such that the bank with low ground needs to be supplemented with an artificially created embankment (Figure 11). As observed from Figure 9, a power canal ends at a forebay, which is broadened to act as a small reservoir. From the forebay, intakes direct the water into the penstocks. There usually is a bye-pass channel which acts as a spillway to pass on excess water in case of a valve closure in the turbine of the hydropower generating unit. If such an escape channel is not provided, there are chances that under sudden closure of the valves of the turbines, surge waves move up the power canal. Hence, sufficient free board has to be provided for the canals.

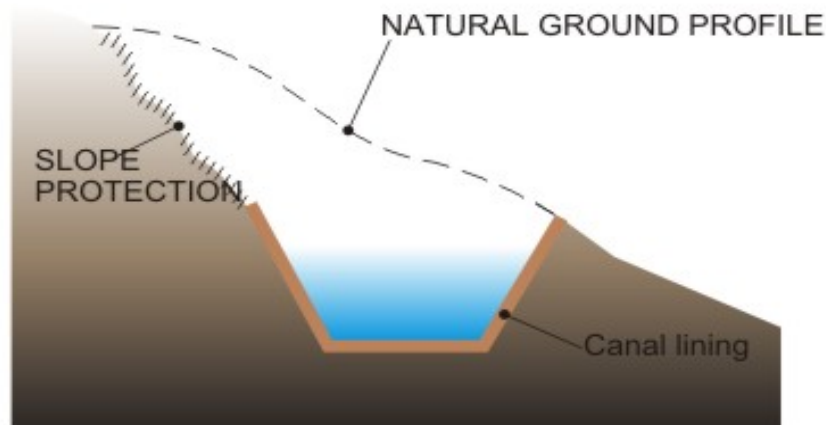

FIGURE 10. Cross section of a power canal in cutting.

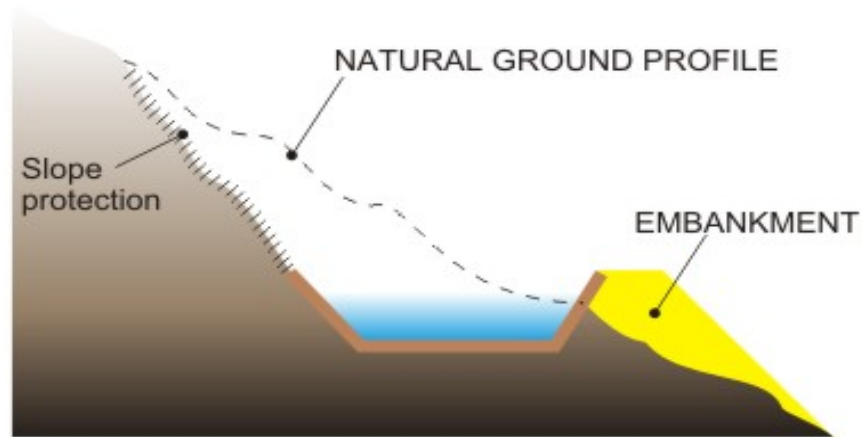

FIGURE 11. Cross section of a power canal in partly cutting & partly filling.

## Tunnels

As shown in Figure 1, a river diversion structure may also direct water into a tunnel. A typical section through a tunnel is shown in Figure 12. The initial portion of the tunnel from the intake up to the Surge-Tank is termed as the Head Race Tunnel (HRT) and beyond that it houses the penstock or steel-conduits, which sustains a larger pressure than the HRT. The HRT may either be unlined (in case of quite good quality rocks) or may be lined with concrete. The surge tank is provided to absorb any surge of water that could be generated during a sudden closure of valve at the turbine end. Normally, the water level in the surge tank would be marginally lower than that at the intake (see Figure 12) and the difference of levels depends upon the friction loss in the HRT. Thus, when the HRT runs full, it is subjected to a much low pressure compared to the penstock. If a HRT is concrete lined, the reinforcement in the concrete may be nominal as the lining is only to assist in preventing fallout of rock blocks into the tunnel. However, if the rock mass above the tunnel is very weak, then the tunnel lining may have to support a larger rock weight, in which case the reinforcement has to be designed accordingly. A tunnel should also be designed for the empty condition, assuming the outside rock to be saturated with water.

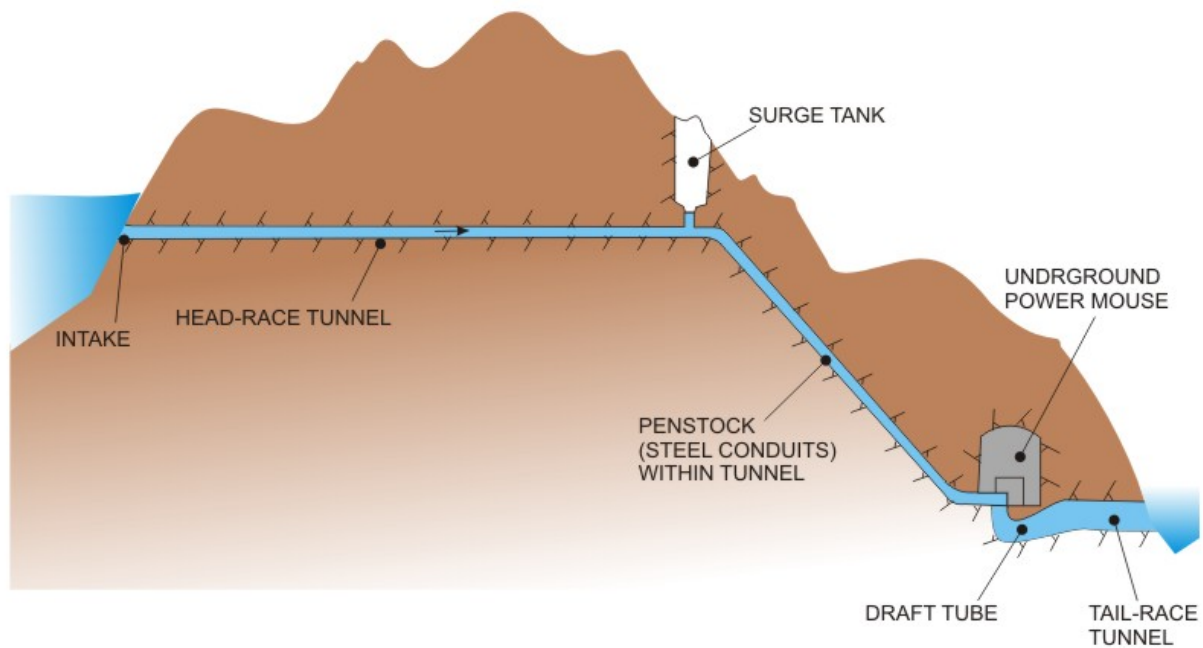

FIGURE 12. Section through a typical tunnel development for water conveyance of a hydropower system.

These aspects pertain to the structural design of a tunnel. Apart from this, there has to be a geometric design, finalising the shape of a tunnel. Section 5.2.3 discuss these issues of tunnel design.

### Surge tanks

As explained, a surge tank (or surge chamber) is a device introduced within a hydropower water conveyance system having a rather long pressure conduit to absorb the excess pressure rise in case of a sudden valve closure. It also acts as a small storage from which water may be supplied in case of a sudden valve opening of the turbine. In case of a sudden opening of turbine valve, there are chances of penstock collapse due to a negative pressure generation. If there is no surge tank.

There are different types of surge tanks that are possible to be installed. The Bureau of Indian Standards code IS: 7396(Part1)-1985 "Criteria for hydraulic design of surge tanks" describes the most common types of surge tanks which are as follows:

1. Simple Surge Tank: A simple surge tank is a shaft connected to pressure tunnel directly or by a short connection of cross-sectional area not less than the area of the head race tunnel (Figure 13).

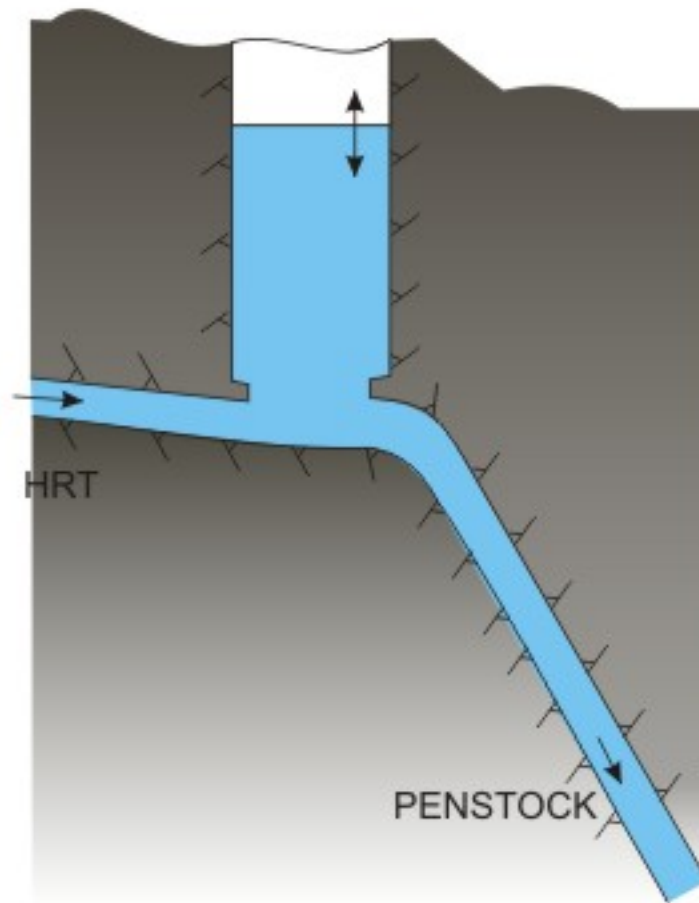

FIGURE 13. Simple surge tank

2. Restricted Orifice Surge Tank: A simple surge tank in which the inlet is throttled to improve damping of oscillations by offering greater resistance and connected to the head race tunnel with or without a connecting/communicating shaft (Figure 14).

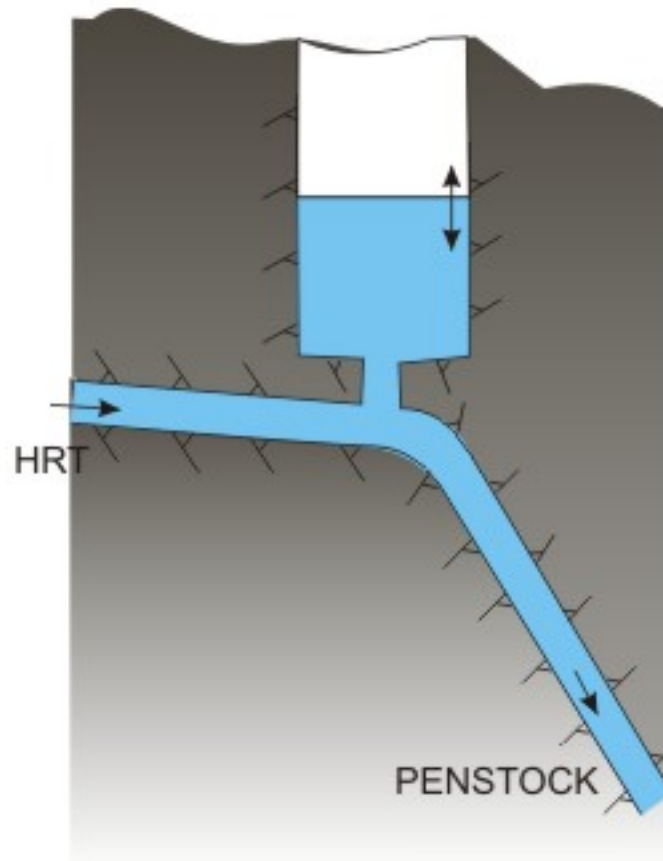

FIGURE 14. Restricted orifice surge tank

3. Differential Surge Tank: Differential Surge tank is a throttled surge tank with an addition of a riser pipe may be inside the main shaft, connected to main shaft by orifice or ports. The riser may also be arranged on one side of throttled shaft as shown in Figure 15. Port holes are generally at the bottom of the riser at the sides.



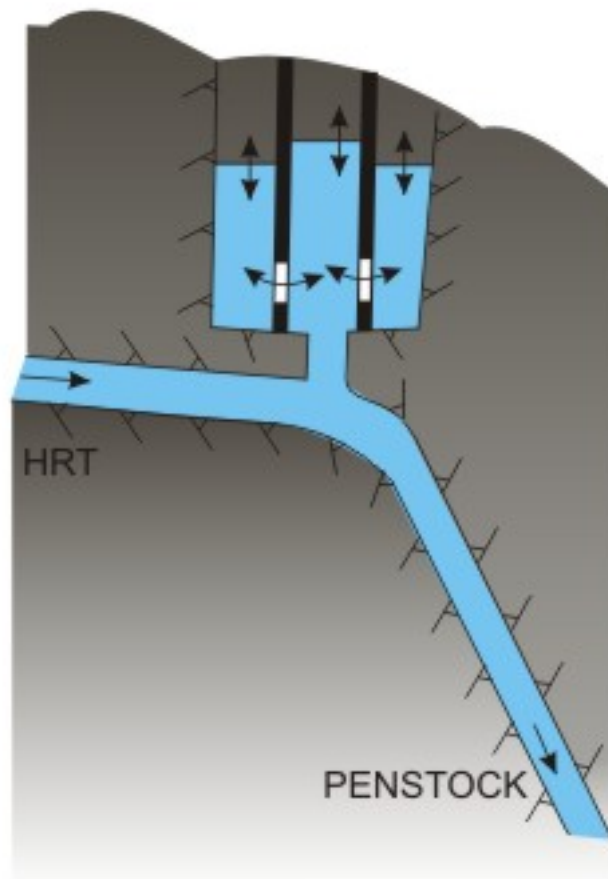

FIGURE 15. Differential surge tank

In an underground development of hydropower system, tail race surge tanks are usually provided to protect tail race tunnel from water hammer effect due to fluctuation in load. These are located downstream of turbines which discharge into long tail race tunnels under pressure. The necessity of tail race surge tank may be eliminated by ensuring free-flow conditions in the tunnel but in case of long tunnels this may become uneconomical than a surge tank.

The Bureau of Indian Standards code IS: 7396(Part2)-1985 deals with the different types of surge tank that may be provided in the Tail Race Tunnel (TRT). A typical view of a surge tank in a TRT is shown in Figure 16.

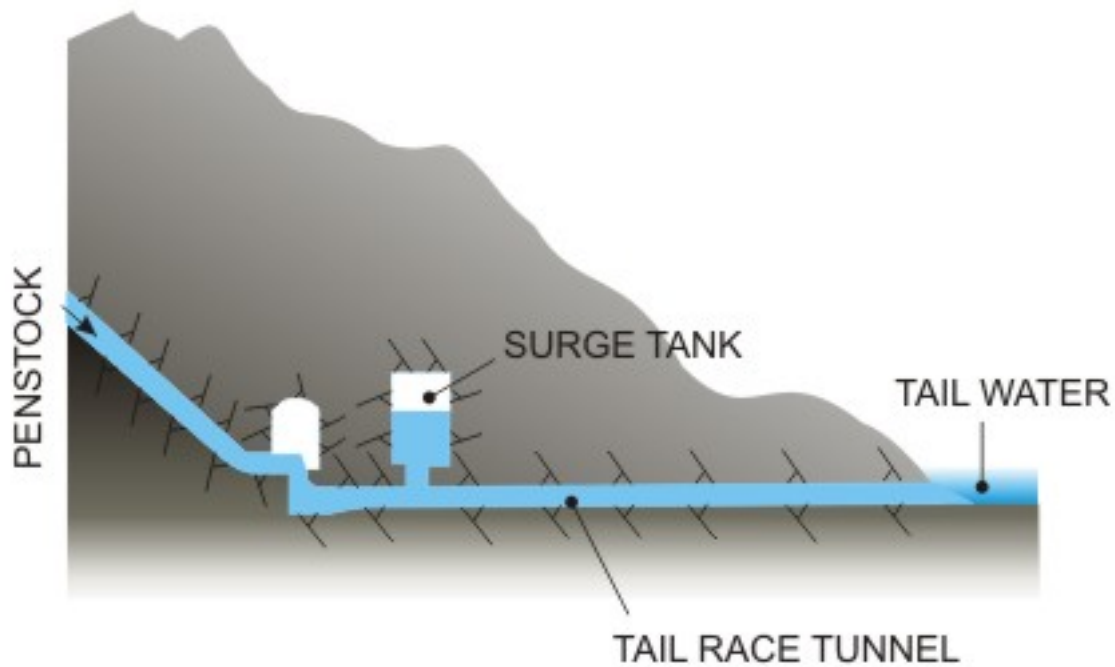
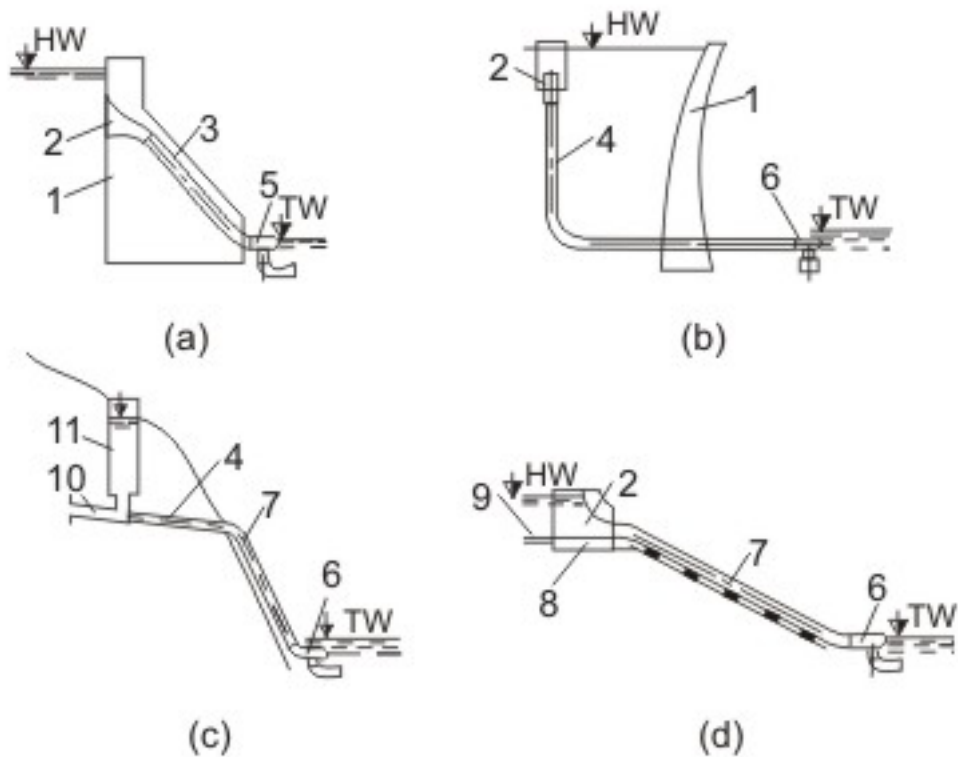

FIGURE 16. Surge tank in tail-race tunnel

Apart from the above types, there could be special types of surge tanks in multiple units which are discussed in IS: 7396 (Part3) and IS: 7396(Part 4) respectively.

### Penstock

A penstock is a steel or reinforced concrete conduit to resist high pressure in the water conveyance system and may take off directly from behind a dam, from a forebay, or from the surge tank end of a head race tunnel as shown in Figure 17. Similar to a tunnel, a penstock needs to be designed for different types of loads. Further, they have to be equipped with different accessories, which may be different for overground or ground embedded types. These aspects of penstocks are thus discussed separately in Section 5.2.4.



1=Dam;2=Intake;3=Embedded or concrete-jacket penstock;  
 4=Tunnel penstock;5=Power house at dam toe;6=Isolated  
 power house;7=Exposed penstock;8=Head pond;9=Diversion  
 conduit;10=Diversion tunnel;11=Surge tank

FIGURE 17. Layout of penstocks.

- a) penstocks of power house built at dam toe;
- b) penstocks of isolated power house;
- c) penstocks of pressure diversion project;
- d) penstocks of open-flow diversion project

### 5.2.3 Tunnels

Tunnels need to be designed and constructed in an efficient manner for the best performance. The Bureau of Indian Standards code IS: 4880-1976 “Code of practice for design of tunnels conveying water” (Parts 1 to 4) provide guidelines for design of a

tunnel under various situations. The following paragraphs provide the salient points from these codes.

## Tunnel layout

The first aspect that needs to be decided for a tunnel is the alignment, that is, the route layout of the tunnel in plan. Figure 18 shows the possible alignment for the tunnel water conveyance system for a hydropower system using tunnel.

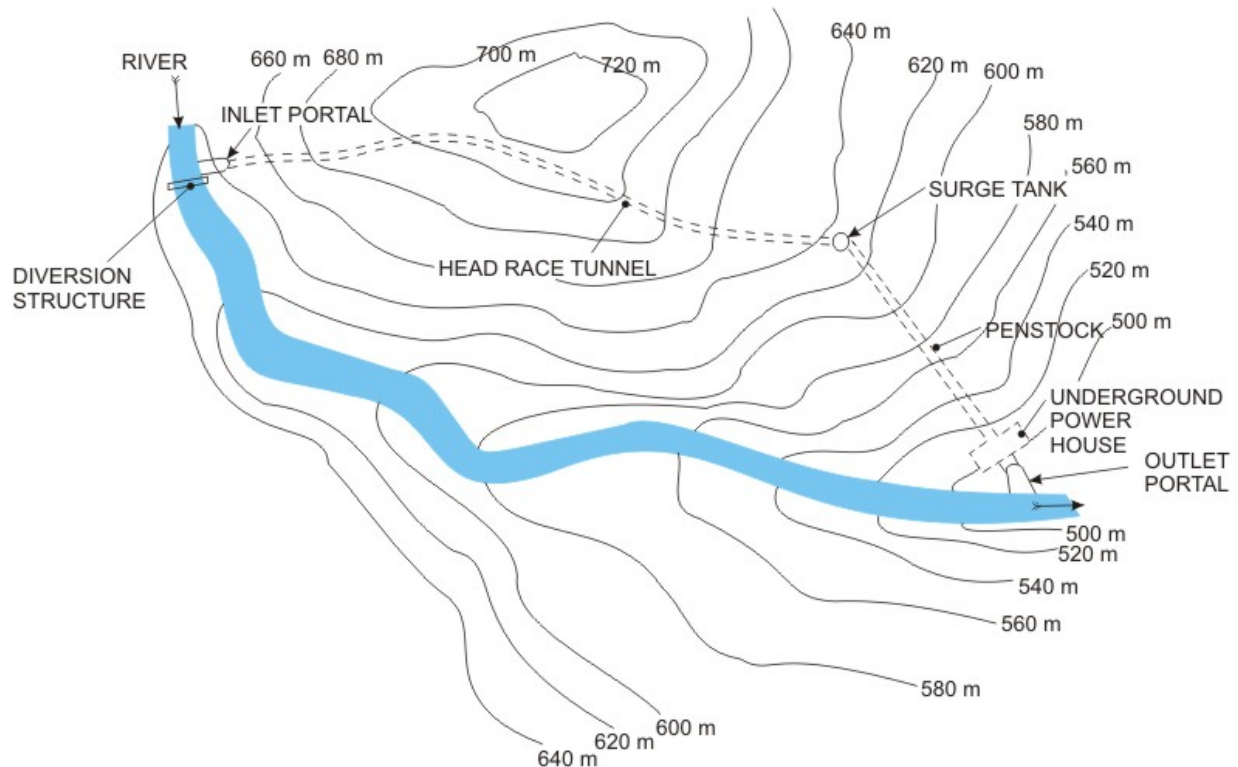

FIGURE 18. Typical layout of a tunnel alignment & other structures

The layout is usually governed by the geological features of the surrounding hills. Complicated geological conditions and extraordinary geological occurrences such as intra-thrust zones, very wide shear zones, geothermal zones of high temperature, cold/hot water springs, water charged rock masses, intrusions, fault planes, etc. should preferably be avoided. Sound, homogeneous isotropic and solid rock formations are the most suitable for tunneling work. However, in the Himalayan region, such conditions are rather rare compared to the hills of peninsular India. This is because the Himalayan geological formations are mostly sedimentary in nature whereas the peninsular upland of the country is of igneous nature. Hence, geological investigations have to be carried out in detail before a tunnel alignment is finalized.

## Tunnel section

The second aspect requires the determination of the size and shape of the tunnel. The size or cross sectional area can be determined from the amount of water that is to be conveyed under the given head difference. Regarding shape, the following types are generally provided for hydropower tunnels:

1. **Circular Section** (Figure 19): The circular section is most suitable from structural considerations. However, it is difficult for excavation, particularly where cross-sectional area is small. For tunnels which are likely to resist heavy inward or outward radial pressures, it is desirable to adopt a circular section. In case where the tunnel is subjected to high internal pressure, but does not have good quality of rock and/or adequate rock cover around it, circular section is considered to be the most suitable.

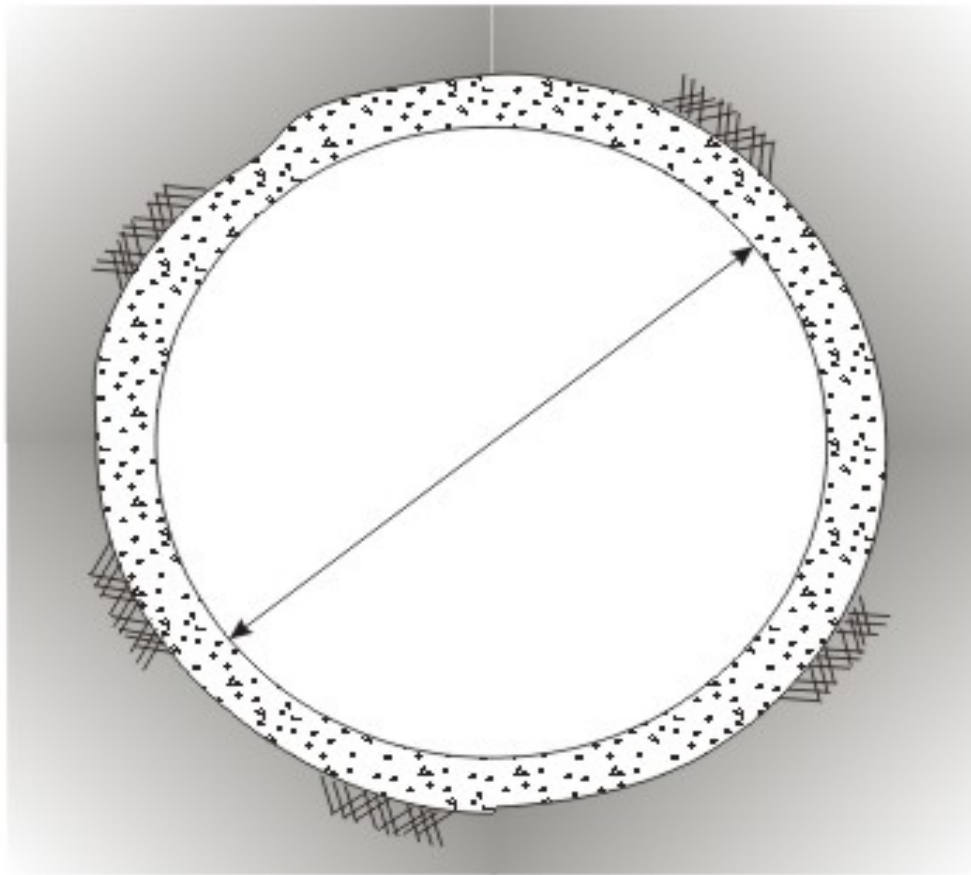

FIGURE 19. Circular shaped section of tunnel

2. **D section** (Figure 20): This type of section would be found suitable in tunnels located in massive igneous, hard, compacted, metamorphic and good quality sedimentary rocks where the external pressures due to water or unsound strata upon the lining is slight and also where the lining is not required to be designed against internal pressure. The principal advantages of this section over horse-shoe section (discussed in next paragraph) are the added width of the invert which gives more working floor space in the heading during driving and the flatter invert which helps to eliminate the tendency of wet concrete to slump and draw away from the tunnel sides after it has been cast.

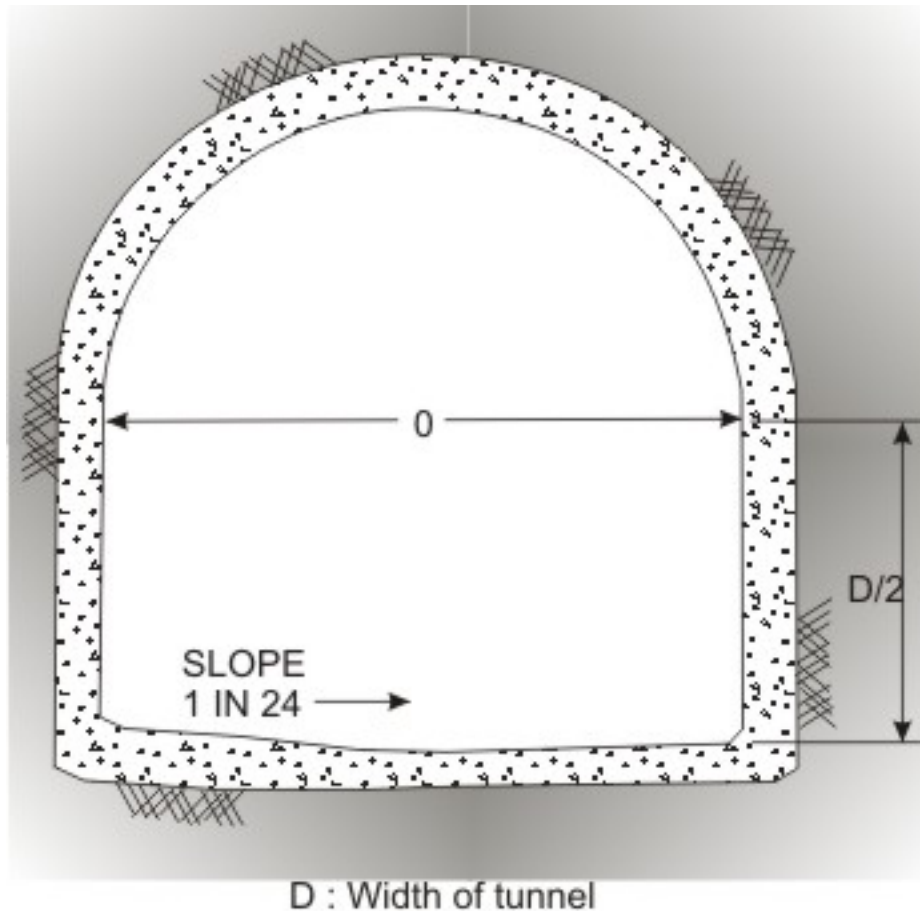

FIGURE 20. D-shaped section of tunnel

3. **Horse-Shoe and Modified Horse-Shoe Sections** (Figure 21 a and b): These sections are a compromise between circular and D sections. These sections are strong in their resistance to external pressures. Quality of rock and adequate rock cover in terms of the internal pressure to which the tunnel is subjected govern the use of these sections. Modified horse-shoe section offers the advantage of flat base for constructional ease and change over to circular section with minimum

additional expenditure in reaches of inadequate rock cover and poor rock formations.

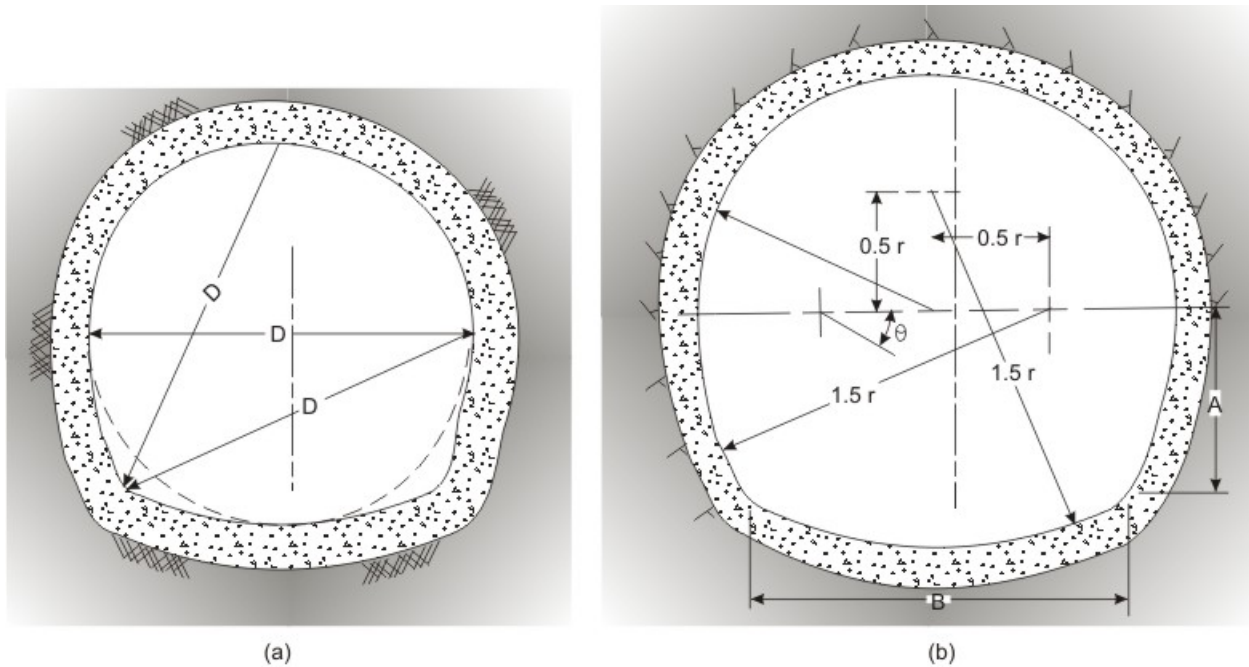

FIGURE 21. (a) Horse shoe section ; (b) Modified horse shoe section of tunnels

4. **Egg Shaped and Egglipse Sections** (Figure 22 a and b): Where the rock is stratified, soft and very closely laminated (as laminated sand stones, slates, micaceous schists, etc) and where the external pressures and tensile forces in the crown are likely to be high so as to cause serious rock falls, egg shaped and egglipse sections should be considered. In the case of these sections there is not much velocity reduction with reduction in discharge. Therefore, these sections afford advantage in cases of sewage tunnels and tunnels carrying sediments. Egglipse has advantage over egg shaped section as it has a smoother curvature and is hydraulically more efficient.

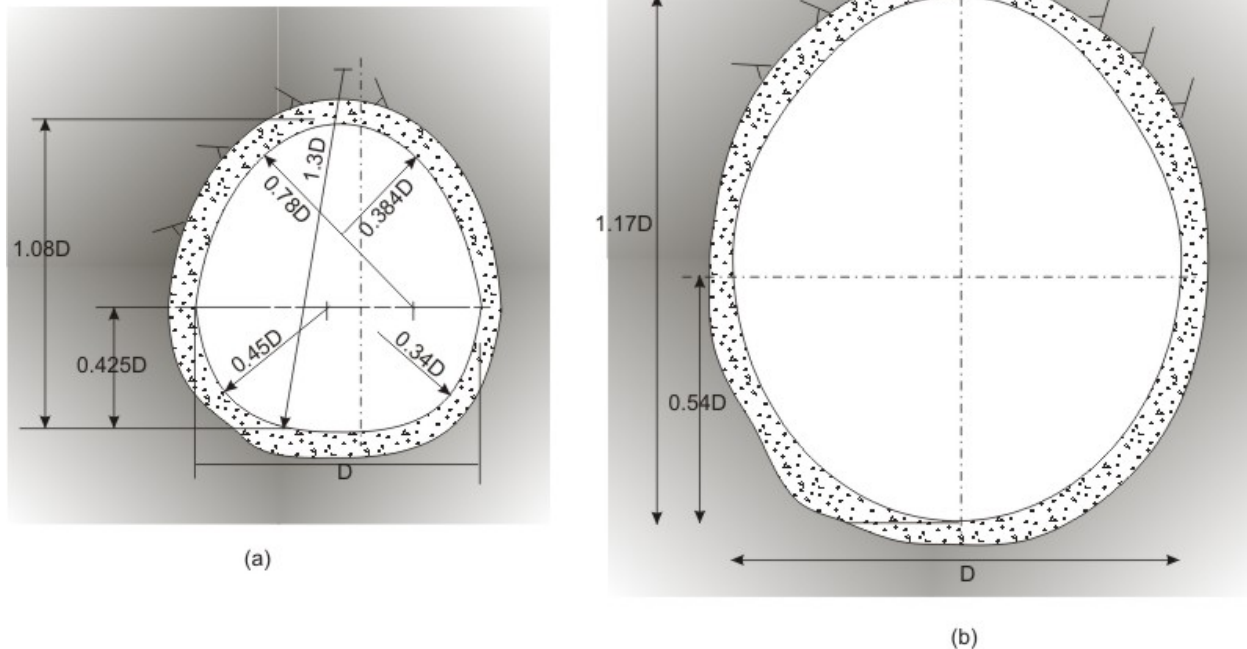

FIGURE 22. (a) Egg shaped section ; (b) Egg lipse section of tunnels

In addition to the sections mentioned above there may be other composite geometrical sections which may be adopted particularly for tunnels which are free flowing and often only partly lined. If the characteristics of a rock formation are fairly well known it may be possible to evolve a section which is likely to fit the shape in which the rock will break naturally. Thus, while a horse-shoe or D section is fairly easy to obtain in some formations there are others where the tunnel crown tends to break into a form more nearly square, and if there is no risk of heavy external pressure upon the lining or if the tunnel is to be unlined there is no reason why the designed cross section should not be made to suit the characteristics of the rock.

### Tunnel entrance and exits

It is also essential to design the entry and exit points of the tunnel very carefully. Where the tunnel emerges out of the hill slope, a structure in the form of an arch is usually provided, which is called the portal (see Figure 18). Since at these points the water enters or leaves the tunnel, they are prone to hydraulic head loss and proper transition shape has to be provided to keep the loss minimum and to avoid cavitation. The length and slope of the transition depends upon the velocity and flow conditions prevailing in the tunnel, economics, construction limitations, etc. It is generally preferred that a hydraulic model study is conducted to arrive at an efficient but economic transition.

Where a tunnel meets a surge tank, some head loss may be expected because of the expansion. Similarly, head losses have also to be taken into account for any contraction as well in the shape of the tunnel. As seen from Figure 15, there could be a possible



change of alignment in plan of a tunnel and this may also lead to a loss in a pressure tunnel.

### **Tunnel flow problems**

The presence of air in a pressure tunnel can be a source of grave nuisance as discussed below:

- a) The localization of an air pocket at the high point in a tunnel or at a change in slope which occasions a marked loss of head and diminution of discharge.
- b) The slipping of a pocket of air in a tunnel and its rapid elimination by an air vent can provoke a water hammer by reason of the impact between two water columns.
- c) The supply of emulsified water to a turbine affects its operation by a drop in output and efficiency thus adversely affecting the operation of generator. The presence of air in a Pelton nozzle can be the cause of water hammer shocks. Admission of air to a pump may occasion loss of priming.
- d) If the velocity exceeds a certain limit air would be entrained causing bulking.

### **Source of Air**

Air may enter and accumulate in a tunnel by the following means:

- a) During filling, air may be trapped along the crown at high points or at changes in cross-sectional size or shape;
- b) Air may be entrained at intake either by vortex action or by means of hydraulic jump associated with a partial gate opening; and
- c) Air dissolved in the flowing water may come out of solution as a result of decreases in pressure along the tunnel.

### **Remedial Measures**

The following steps are recommended to prevent the entry of air in a tunnel:

- a) Shallow intakes are likely to induce air being sucked in. Throughout the tunnel the velocity should either remain constant or increase towards the outlet end. It should be checked that at no point on the tunnel section negative pressures are developed.
- b) Vortices that threaten to supply air to a tunnel should be avoided, however, if inevitable they should be suppressed by floating baffles, hoods or similar devices.
- c) Partial gate openings that result in hydraulic jumps should be avoided.
- d) Traps or pockets along the crown should be avoided.

### **Tunnel structural design**

The geometric and hydraulic design of a tunnel is followed by the structural design, which investigates the loads that are expected on the tunnel opening from the surrounding rockmass and whether a support is required to hold it in place or a lining is necessary to resist the pressure of the rock and water pressure from the saturated joints and cracks of the surrounding rocks.

Only some limited geological formations are so perfectly intact that they require no external support for their stability. In general, most of the tunnels are driven through rocks with certain defects requiring provision of some form of support until a lining can be completed. Thus, the basic philosophy of design of an underground excavation (tunnelling, surge tanks, power houses etc.) is such as to utilise the rock mass itself as the principal structural material, creating as little disturbance as possible during the excavation process and adding as little as possible in the way of steel supports or shotcrete (which is a wire mesh fixed to the tunnel wall by nails and sprayed with cement slurry with or without steel fibre is used to form a layer, as explained further on). The type of rock support that has to be provided for a tunnel depends upon the type of rock quality, which is classified according to its behaviour when an opening is made in the rock. The Bureau of Indian Standards code IS: 15026-2002 "Tunnelling methods in rock masses-guidelines" indicates the features of the various types of rocks that are generally encountered. It also recommends the type of excavation method that is to be adopted and the type of support that would be appropriate.

The methods for providing temporary or permanent supports to the tunnels are as described the following paragraphs:

### **Steel supports**

These are built of steel sections, usually I-sections, either shaped or welded in pieces in the form of a curve or a straight section as shown in Figure 23.

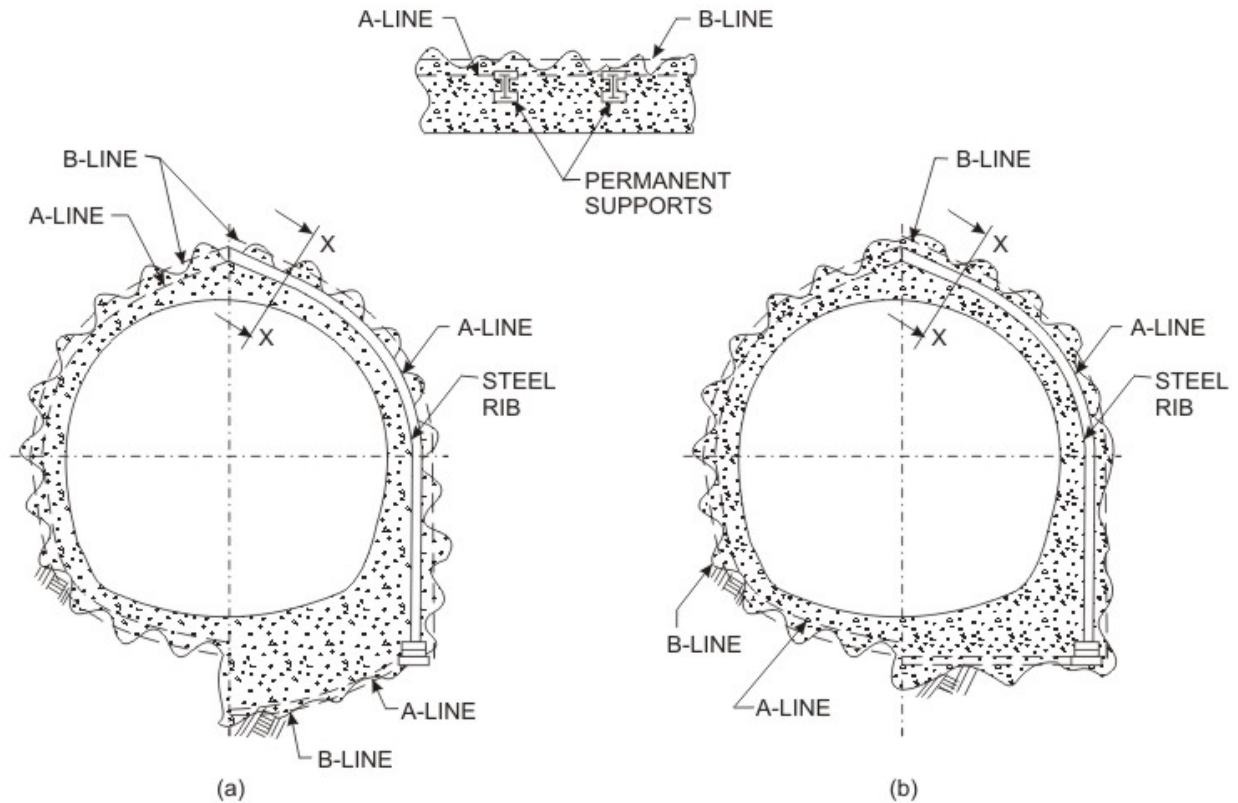

FIGURE 23. Steel support for tunnel and finished in the form of (a) Horse shoe section & (b) Circular section

IS: 15026-2002 recommends various types of steel sections, also called steel ribs, as follows:

- a) Continuous rib (Figure 24a)
- b) Rib and post (Figure 24b)
- c) Rib and wall plate (Figure 24c)
- d) Rib, wall plate and post (Figure 24d)
- e) Full circle rib (Figure 24e)
- f) Invert strut with continuous rib (Figure 24f)

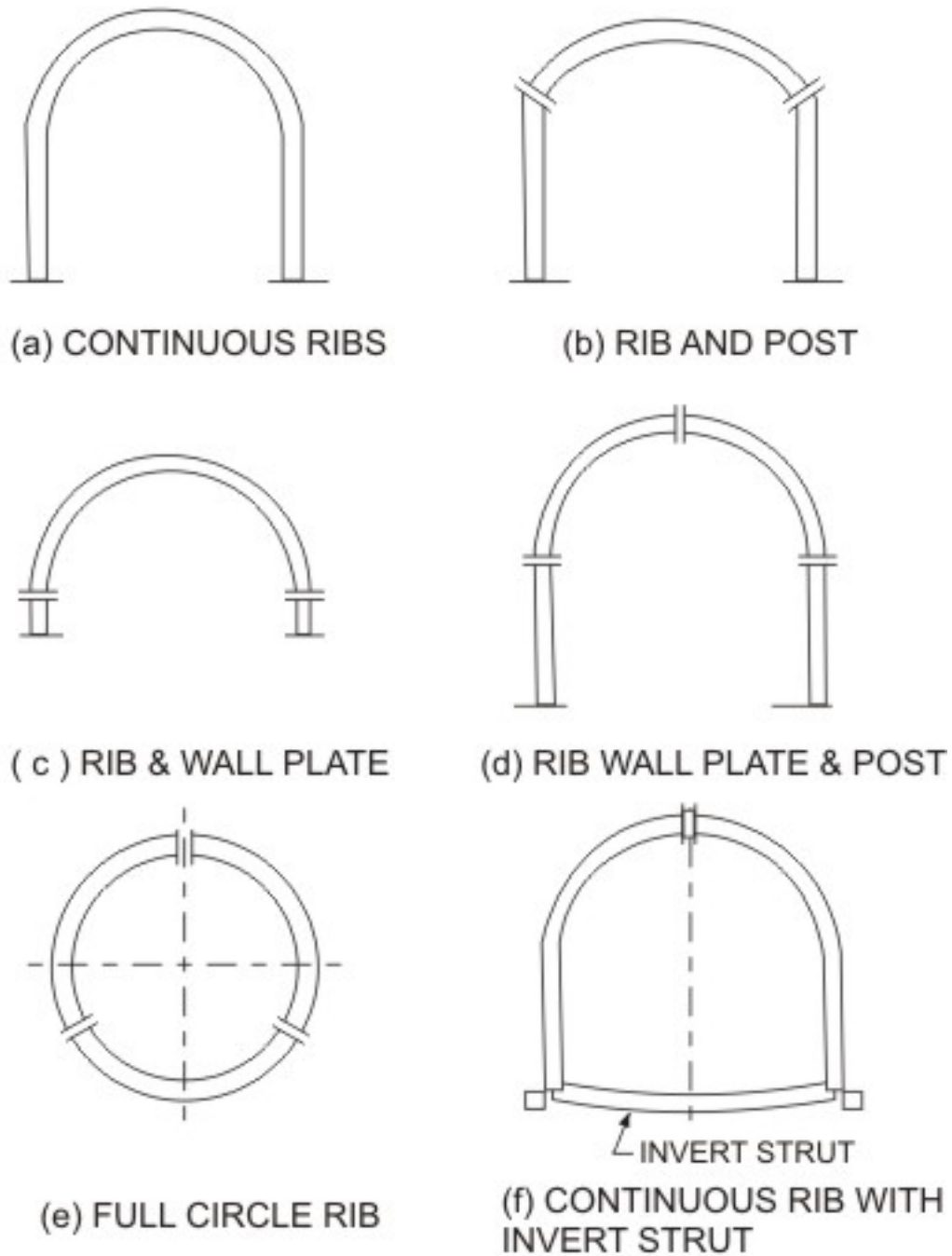

FIGURE 24. Types of steel support system

### Grouting

This is a cement mortar with proportion of cement, sand and water in the ratio 1:1:1 by weight usually, though it may be modified suitably according to site conditions.

Grouting is carried out to fill discontinuities in the rock by a suitable material so as to improve the stability of the tunnel roof or to reduce its permeability or to improve the properties of the rock. Grouting is also necessary to ensure proper contact of rock face of the roof with the lining. In such cases grouting may be done directly between the two surfaces. All the different types of grouting may not be required in each case. The grouting procedures should aim at satisfying the design requirements economically and in conformity with the construction schedules. The basic design requirement generally involve the following:

- a) Filling the voids, cavities, between the concrete lining and rock and /or between the concrete and steel liner;
- b) Strengthening the rocks around the bore by filling up the joints in the rock system;
- c) Strengthening the rock shattered around the bore;
- d) Strengthening the rock, prior to excavation by filling the joints with cementing material and thus improving its stability; and
- e) Closing water bearing passages to prevent the flow of water into the tunnel and/or to concentrate the area of seepage into a channel from where it can be easily drained out.

### Rock/roof bolts

Roof bolts are the active type of support that improve the inherent strength of the rock mass which acts as the reinforced rock arch whereas, the conventional steel rib supports are the passive supports and supports the loosened rock mass externally. All rock bolts should be grouted very carefully in its full length.

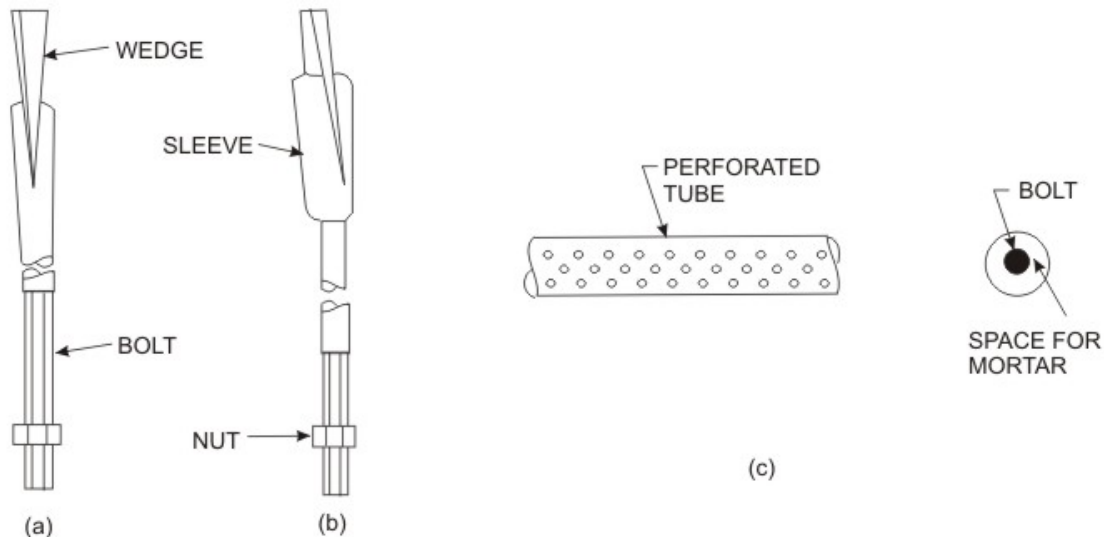

FIGURE 25 Different types of rock/roof bolts  
 (a) Wedge & slot bolt  
 (b) Wedge & sleeve bolt  
 (c) Perfo bolts

There are many types of rock bolts and anchors which may also be used on the basis of past experience and economy. The common types of rock bolts used in practice are the following:

### **Wedge and Slot bolt**

These consist of mild-steel rod, threaded at one end, the other end being split into two halves for about 125 mm length. A wedge made from 20 mm square steel and about 150mm long shall be inserted into the slot and then the bolt with wedge driven with a hammer into the hole which will force the split end to expand and grip the rock inside the hole forming the anchorage. Thereafter, a 10 mm plate of size 200×200 mm shall be placed over which a tapered washer is placed and the nut tightened (see Figure 25a). The efficiency of the splitting of the bolt by the wedge depends on the strata at the end of the hole being strong enough to prevent penetration by the wedge end and on the accuracy of the hole drilled for the bolt. The diameter of such bolt may be 25mm or 30mm. Wedge and slot bolts are not effective in soft rocks.

### **Wedge and Sleeve bolts**

This consists of a 20 mm diameter rod, one end of which is cold-rolled threaded portion while other end is shaped to form a solid wedge forged integrally with the bolt and over this wedge a loose split sleeve of 33 mm external diameter is fitted (see Figure 25b). The anchorage is provided in this case by placing the bolt in the hole and pulling it downwards while holding the sleeve by a thrust tube. Split by the wedge head of the bolt, the sleeve expands until it grips the sides of the tube. Special hydraulic equipment is needed to pull the bolts.

### **Perfo bolts**

This method of bolting consists of inserting into a bore hole a perforated cylindrical metal tube which is previously filled with cement mortar and then pushing a plain or ribbed bolt. This forces part of the mortar to ooze out through the perforations in the tube and come into intimate contact with the sides of the bore hole thus cementing the bolt, the tube and the rock into one homogeneous whole (see Figure 25c).

### **Steel fibre reinforced shotcrete (SFRS)**

Steel fibre reinforced shotcrete either alone or in combination with rock bolts (specially in large openings) provides a good and fast solution for both initial and permanent rock support. Being ductile, it can absorb considerable deformation before failure.

Controlled blasting should be used preferably. The advantage of fibre reinforced shotcrete is that smaller thickness of shotcrete is needed, in comparison to that of conventional shotcrete. Fibre reinforced shotcrete along with resin anchors is also recommended for controlling rock burst conditions because of high fracture toughness of shotcrete due to specially long steel fibres. This can also be used effectively in highly squeezing ground conditions. It ensures better bond with rock surface. With mesh, voids and pockets might form behind the mesh thus causing poor bond and formation of water seepage channels as indicated in Figure 26.

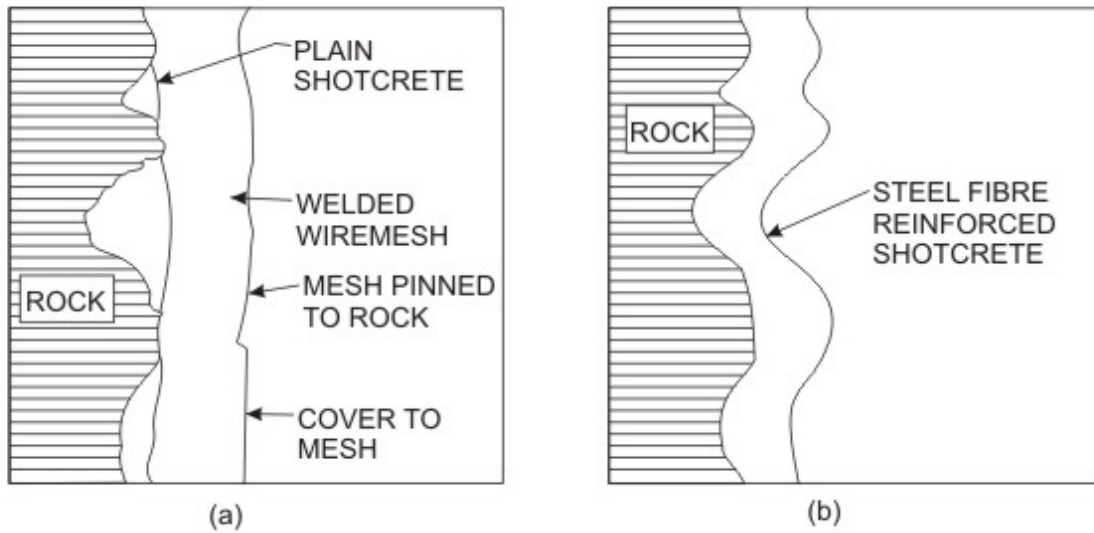

FIGURE 26. Differences in shotcrete consumption when wire mesh (a) or steel fibres (b) are used

The major draw-back of normal shotcrete is that it is rather weak in tensile, flexural and impact resistance strength. These mechanical properties are improved by the addition of steel fibres. Steel fibres are commonly made into various shapes to increase their bonding intimacy with the shotcrete (see Figure 27). It is found that hooked ends types of steel fibres behave more favourably than other types of steel fibres in flexural strength and toughness. Accelerators play a key role to meet the requirement of early strength.

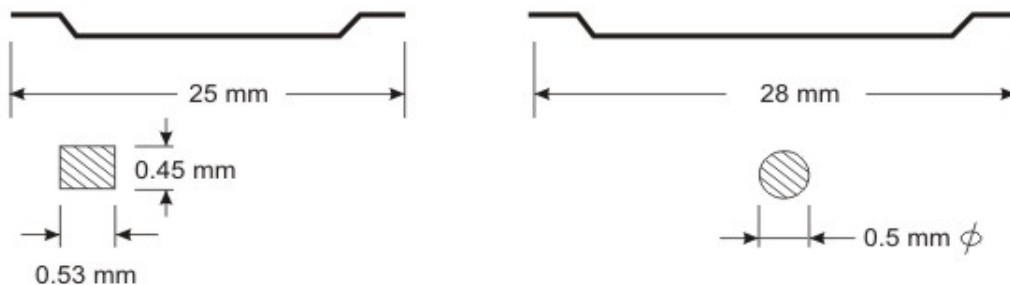

FIGURE 27. Typical fibre used in shotcrete work.

Steel fibres make up between 0.5 to 2 percent of the total volume of the mix (1.5 to 6 percent by weight). Shotcrete mixes with fibre contents greater than 2 percent are difficult to prepare and shot.

### Concrete lining

This is a protective layer within the tunnel made of plain or reinforced concrete. Tunnels may be completely lined, partially lined, or even unlined. Tunnels in good sound rock may be kept unlined. However, lining is recommended when:

- a) The internal water pressure exerted by water conveyed by the tunnel is high, say above 100m of water head. For very good competent rock, tunnels may be kept unlined for pressures even up to 200m water head.
- b) The rock strata through which the tunnel passes has low strength and where the rock is anisotropic.

Lining a tunnel increases the cost of a project and should be adopted considering the advantages expected as given below:

- a) Lining transmits part of the internal water pressure to the surrounding rock which, to some extent, is balanced by the external rock pressure. In tunnel empty condition, it helps to resist the external rock load together with the support system.
- b) Lining may be carried together with the tunnel excavation work and hence minimizes the danger of accidental rock falls within the tunnel.
- c) Lining helps to reduce water loss through joints in rocks by seepage.
- d) Lining is invariably provided at the inlet and outlet portals of a tunnel, even if located within competent rock.

Tunnels conveying water under free flow conditions may be un-reinforced. The external rock load is expected to be carried by the steel supports. Usually, a tunnel lining has to be reinforced when the depth of rock cover (from the tunnel soffit up to the free surface of the hill) is less than the internal water pressure.

The design of concrete linings for tunnels may be done according to the recommendations of the following Bureau of Indian Standards code IS: 4880(Part IV)-1971 "Code of practice for design of tunnels conveying water (structural design of concrete lining in soft strata and soils".

The construction of tunnels could be by manual methods like drilling holes, placement of explosive, blasting, and then removal of the muck from the head-face or by competent rocks well. As soon as the tunnel face is excavated to a certain depth, the temporary supports are provided to prevent any rock fall or squeezing. At the same time, or later, permanent supports are also put in place.

### 5.2.4 Penstocks

As mentioned before, a penstock is usually steel or reinforced concrete lined conduit that supplied water from the reservoir, forebay or surge tank at the end of a head race



tunnel to the turbines. A penstock is subjected to very high pressure and its design is similar to that for pressure vessels and tanks. However, sudden pressure rise due to valve closure of turbines during sudden load rejection in the electric grid necessitates that penstocks be designed for such water hammer pressures as well. Penstocks, at their lowermost end meets a controlling valve, from where the water is led to the spiral casing of the turbine, details of which would be discussed in the next lesson.

Since penstocks convey water to the turbines and form a part of the hydropower water conveyance system, it is necessary that they provide the least possible loss of energy head to the flowing water. According to the Bureau of Indian Standards code IS: 11625-1986 “Criteria for hydraulic design of penstocks”, the following losses may be expected for a penstock:

- a. Head loss at trash rack
- b. Head loss at intake entrance
- c. Friction losses, and
- d. Other losses as at bends, bifurcations, transitions, valves, etc.

Based on the above losses, the diameter of the penstock pipes have to be fixed, such that it results in an overall economy. This is because if the diameter of a penstock is increased, for example, the friction losses reduce resulting in a higher head at turbine and consequent generations of more power. But this, at the same time, increases the cost of the penstock. This leads to the concept of Economic Diameter of Penstock which is one such that the annual cost, including cost of power lost due to friction and charges of amortization of construction cost, maintenance, operation, etc. is the minimum.

A penstock made of steel may be constructed as a seamless pipe, rolled or drawn from mild steel if the diameter is within 0.5m. Larger diameter pipes are usually manufactured from steel plates welded together. The joints have to be carefully tested by ultrasonic or radiographic methods which ensures that high pressure may be tolerated by the pipes.

Penstocks may also be classified according to their location with respect to the ground surface. If they are buried within ground or laid inside a tunnel drilled (see Figure 18) within the mass of a hill, then they have to be designed to take the load of the surrounding soil or rock. Such buried or embedded penstocks may be differentiated from those that are laid above the ground surface, termed as the surface penstocks, which are subjected to variation in temperature of the surroundings especially due to the sun’s direct radiation. Such and other advantages and disadvantages of embedded and surface penstocks may be listed as under:

Sl. No	<b><i>Embedded Penstocks</i></b>	<b><i>Surface Penstocks</i></b>
1.	Protection against temperature effect	Subjected to temperature variations
2.	Landscape does not get affected	Landscape becomes scared with the Penstocks presence

3.	Less accessible for inspection	Easily accessible for inspection
4.	Greater expenses for large diameter penstocks in rocky soil	Economical under such circumstances
5.	Does not require separate support. Does not require expansion joints	Requires anchorages for support necessitating in expansion joints

The following Bureau of Indian Standards codes may be referred for the design of embedded and surface penstocks respectively.

IS: 11639-1986 “Criteria for structural design of penstocks”

Part1: Surface penstocks

Part2: Buried / embedded penstocks

A penstock is not only a single straight piece of pipeline. It has to certain additional pieces, called specials, to allow it to be located over undulating terrain or within curved or contracted tunnels, provide access for inspection, etc. Design of these special attachments to a penstock is provided by the Bureau of Indian Standards code IS: 11639(Part3)-1996 “Structural design of penstocks-criteria (Specials for penstocks)”. The following paragraphs briefly described these specials and the purpose they serve.

### **Bends**

Depending on topography, the alignment of the penstock is often required to be changed, in direction, to obtain the most economical profile so as to avoid excess excavation of foundation strata and also to give it an aesthetic look with the surroundings. These changes in direction are accomplished by curved sections, commonly called penstock bends. For ease of fabrication, the bends are made up of short segments of pipes with mitered ends.

Bends may be only in one plane, in which case it is known as a simple bend. If the curvature or change in alignment is in two planes- horizontal as well as vertical- then it is called a compound bend.

### **Reducer piece**

In the case of very long penstocks, it is often necessary to reduce the diameter of the pipe as the head on the pipe increases. This reduction from one diameter to another should be effected gradually by introducing a special pipe piece called reducer piece. The reducer piece is a frustum of a cone. Normally the angle of convergence should be kept between 5 degrees to 10 degrees so as to minimize the hydraulic loss at the juncture where the diameter is reduced.

### **Branch pipe**

Depending upon the number of units a single penstock feeds, the penstock branching is defined as bifurcation when feeding two units, trifurcation when feeding three units and manifold when feeding a greater number of units by successive bifurcations. Branch pipes of bifurcating type are generally known as “wye” pieces which may be symmetrical or asymmetrical.

Generally the bifurcating pipe has two symmetric pipes, after the bifurcating joints, and the deflection angle of the branching pipes ranges between 30degrees to 75 degrees. In order to reduce the head loss, a smaller deflection angle is advantageous. However, the lesser the bifurcating angle, greater the reinforcement required at the bifurcating part. The wye branches should be given special care in design to ensure safety of the assembly under internal pressure of water. The introduction of a bifurcation considerably alters the structural behavior of the penstock in the vicinity of the branching.

### **Expansion joints**

Expansion joints are installed in exposed penstocks between fixed point or anchors to permit longitudinal expansion, or contraction when changes in temperature occur and to permit slight rotation when conduits pass through two structures where differential settlement or deflection is anticipated. The expansion joints are located in between two anchor blocks generally downstream of uphill anchor block. This facilitates easy erection of pipes on steep slopes.

Expansion joints should have sufficient strength and water tightness and should be constructed so as to satisfactorily perform their function against longitudinal expansion and contraction. The range of variations to be used for calculation of expanded or contracted length of penstocks should be determined keeping in consideration the maximum and minimum temperature of the erection sites.

### **Manholes**

Manholes are provided in the course of the penstock length to provide access to the pipe interior for inspection, maintenance and repair.

The normal diameter of manholes is 500 mm. Manholes are generally located at intervals of 120-150 metres. For convenient entrance, exit manholes on the penstock may be located on the top surface or lower left or right surface along the circumference of the penstock.

The manhole, in general, consists of a circular nozzle head, or wall, at the opening of the pipe, with a cover plate fitted to it by bolts. Sealing gaskets are provided between nozzle head and cover plate to prevent leakage. The nozzle head, cover plates and bolts should be designed to withstand the internal water pressure head in the penstock at the position of the manhole.

### **Bulk heads**

Bulkheads are required for the purpose of hydrostatic pressure testing of individual bends, after fabrication, and sections or whole of steel penstock and expansion joints, before commissioning. Bulkheads are also provided whenever the penstocks are to be closed for temporary periods, as in phased construction.

### **Air vents and valves**

These are provided on the immediate downstream side of the control gate or valve to facilitate connection with the atmosphere.

Air inlets serve the purpose of admitting air into the pipes when the control gate or valve is closed and the penstock is drained, thus avoiding collapse of the pipe due to vacuum excessive negative pressure. Similarly, when the penstock is being filled up, these vents allow proper escape of air from the pipes.

The factors governing the size of the vents are length, diameter, thickness, head of water, and discharge in the penstock and strength of the penstock under external pressure.

### **Manifold**

The portion beyond the main penstock which feeds the branches for the individual units, when two or more units are fed from one penstock. Apart from the above, the following are required for aligning and holding a penstock in place.

### **Anchorage/ Anchor Block/Anchor pier**

This is a structure built to hold down penstocks in position at the points where the direction or inclination of the axis changes and also at some regular intervals. In the closed type of anchor, the penstock is embedded in concrete. In the open-type, the penstock is anchored to concrete by rings. Intermediate supports are also provided for penstocks between two anchor blocks, over which the pipe can slide while expanding or contracting. Sometimes thrust blocks are provided on either side of branch connections to resist unbalanced forces at the penstock connection and thus maintain alignment of outlet headers.

### **Concrete saddle supports**

These are a type of intermediate supports with concrete base shaped to suit the bottom of the pipe. A well lubricated steel plate, rolled to suit the shape of the pipe shell in contact, is provided in between the concrete surface and the pipe to facilitate smooth movement of the pipe over saddles.