

# Module

# 4

# Hydraulic Structures for Flow Diversion and Storage

# Lesson

# 6

## Design and Construction of Concrete Gravity Dams

## Instructional objectives

On completion of this lesson, the student shall learn:

1. The different components of concrete gravity dams and their layouts
2. Design steps for of concrete gravity dam sections
3. The expected loadings for gravity dams
4. Stability analysis of gravity dam sections
5. Construction processes for gravity dams
6. Foundation preparation for gravity dams
7. Temperature control for mass concrete dams
8. Instrumentations in concrete dams

### 4.6.0 Introduction

Dams constructed out of masonry or concrete and which rely solely on its self weight for stability fall under the nomenclature of gravity dams. Masonry dams have been in use in the past quite often but after independence, the last major masonry dam structure that was built was the **Nagarjunsagar Dam** on river **Krishna** which was built during 1958-69. Normally, coursed rubble masonry was used which was bonded together by lime concrete or cement concrete. However masonry dam is no longer being designed in our country probably due to existence of alternate easily available dam construction material and need construction technology. In fact, gravity dams are now being built of mass concrete, whose design and construction aspects would be discussed in this chapter. There are other dams built out of concrete like the Arch/Multiple Arch or Buttress type. These have however not been designed or constructed in India, except the sole one being the arch dam at **Idukki** on river **Periyar**. In India the trend for concrete dam is only of the gravity type and therefore the design other types of concrete dams have not been discussed in this course. Interested readers may know more about such dams from standard books on the subject like Engineering of Large Dams by Henry H. Thomas, Volumes I and II published by John Wiley and Sons (1976). A slightly outdated publication, Engineering of Dams, Volumes I, II and III by W P Creager, J D Justin, and J Hinds published by John Wiley and Sons (1917) has also been long considered a classic in dam engineering, though many new technologies have do not find mention here.

It is important to note that, it is not just sufficient to design a strong dam structure, but it is equally important to check the foundation as well for structural integrity. For concrete dams, the stress developed at the junction of the base becomes quite high, which the foundation has to resist. Usually concrete gravity dams are constructed across a river by excavating away the loose overburden till firm rock is encountered which is considered as the actual foundation. Nevertheless not all rocks are of the same quality; they vary with different geological materials and the process by which they have been formed over the years. For example, the hills of the Himalayan range of the mountains are considered geologically young, as well as weaker than the massif of the Deccan

plateau. The quality of foundation not only affects the design, it also guides the type of dam that would be suited at a design site. Hence, discussions on the ground foundation aspects have been introduced in this lesson as well.

It may also be realized that designing a dam based on field data (like the geometry of the river valley, the foundation allowable bearing capacity .etc) is not the only part that a water resource engineer has to do. He has to get it constructed at the design site which may easily take anywhere between 5 to 10 years or even more depending on the complexity of the work and the volume and type of the structure. It may easily be appreciated that constructing a massive structure across a flowing river is no easy task. In fact tackling of the monsoon flows during the years of construction is a difficult engineering task.

### 4.6.1 Concrete gravity dam and apparent structures- basic layout

The basic shape of a concrete gravity dam is triangular in section (Figure 1a), with the top crest often widened to provide a roadway (Figure 1b).

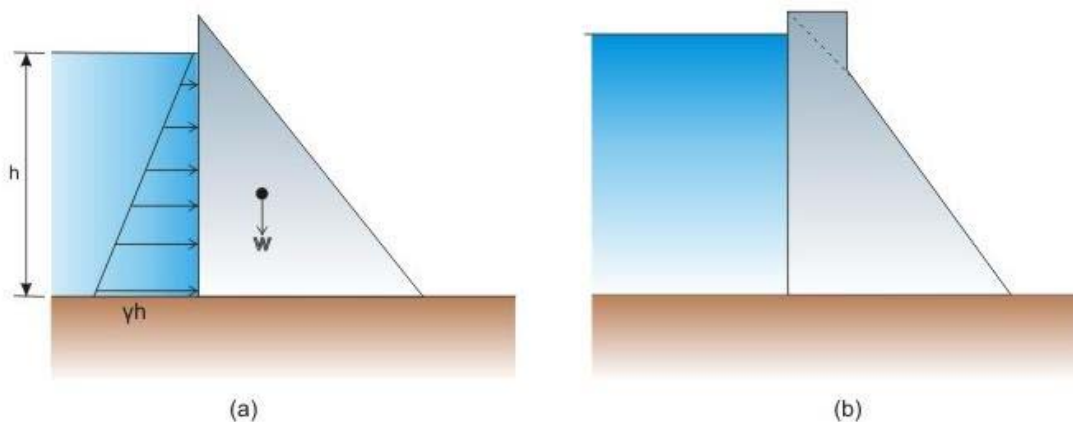

FIGURE 1 : Concrete gravity dam section (a) Basic triangular shape (b) Modified shape

The increasing width of the section towards the base is logical since the water pressure also increases linearly with depth as shown in Figure 1a. In the figure,  $h$  is assumed as the depth of water and  $\gamma h$  is the pressure at base, where  $\gamma$  is the unit weight of water ( $9810 \text{ N/m}^3$ ),  $W$  is the weight of the dam body. The top portion of the dam (Figure 1b) is widened to provide space for vehicle movement.

A gravity dam should also have an appropriate spillway for releasing excess flood water of the river during monsoon months. This section looks slightly different from the other non-overflowing sections. A typical section of a spillway is shown in Figure 2.

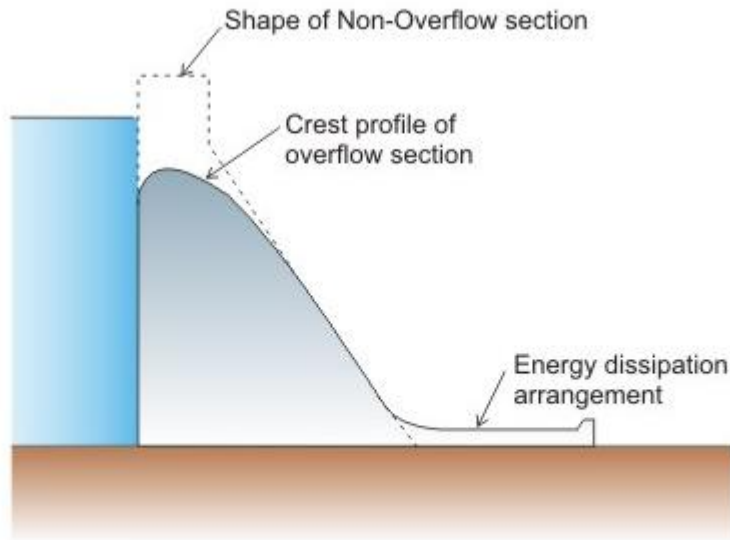

FIGURE 2: Typical overflow section of a gravity dam

The flood water glides over the crest and downstream face of the spillway and meets an energy dissipating structure that helps to kill the energy of the flowing water, which otherwise would have caused erosion of the river bed on the downstream. The type of energy dissipating structure shown in Figure 2 is called the stilling basin which dissipates energy of the fast flowing water by formation of hydraulic jump at basin location. This and other types of spillway and energy dissipators are discussed in a subsequent section. Figure 3 shows the functioning of this type of spillway

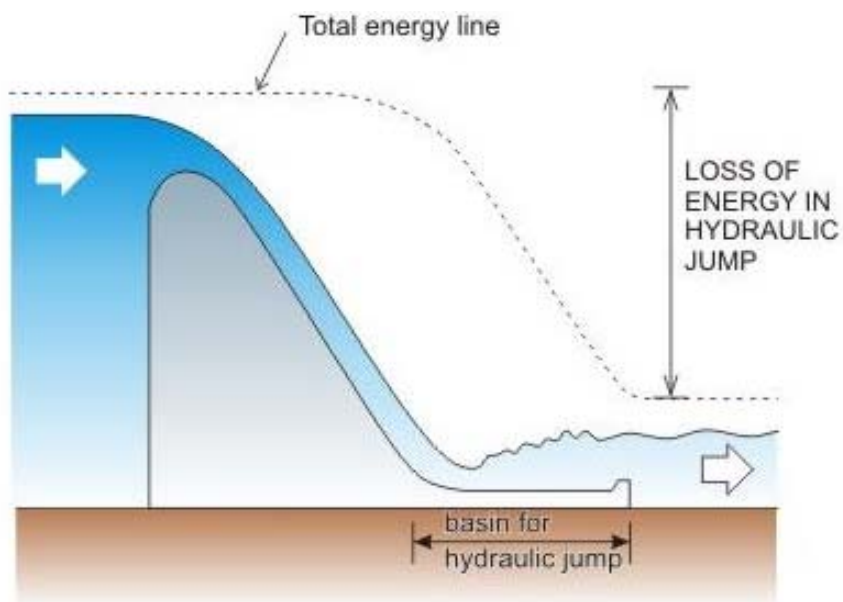

FIGURE 3: Water flowing over a spillway

Usually, a spillway is provided with a gate, and a typical spillway section may have a radial gate as shown in Figure 4. The axis or **trunnion** of the gate is held to **anchorages** that are fixed to **piers**.

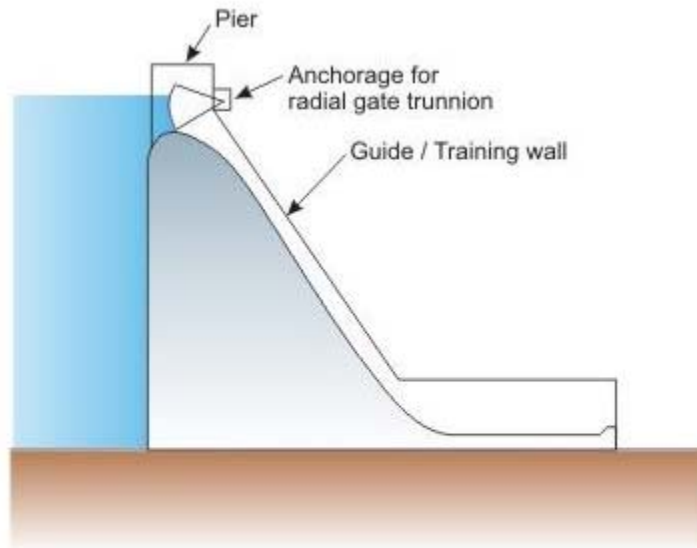

FIGURE 4. A gated spillway section

Also shown in the figure is a **guide wall** or **training wall** that is necessary to prevent the flow crossing over from one bay (controlled by a gate) to the adjacent one. Since the width of a gate is physically limited to about 20m (limited by the availability of hoisting motors), there has to be a number of bays with corresponding equal number of gates separated by guide walls in a practical dam spillway.

The upstream face of the overflowing and non-overflowing sections of a gravity dam are generally kept in one plane, which is termed as the dam axis or sometimes referred to as the dam base line (Figure 5).

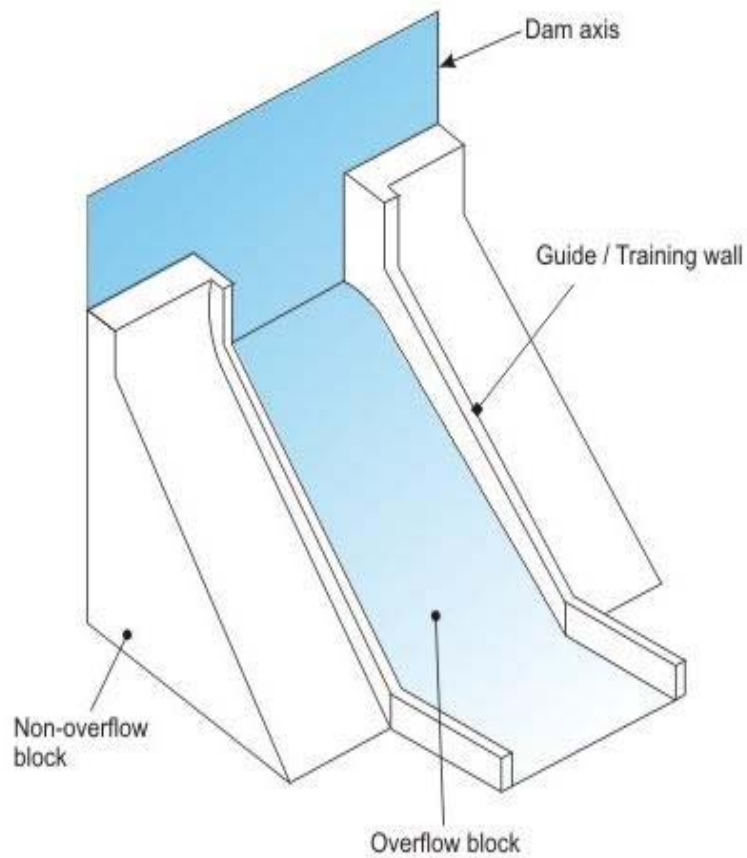

FIGURE 5. Co-planar upstream faces of overflow and non-overflow blocks.

Since the downstream face of the dam is inclined, the plane view of a concrete gravity dam with a vertical upstream face would look like as shown in Figure 6.

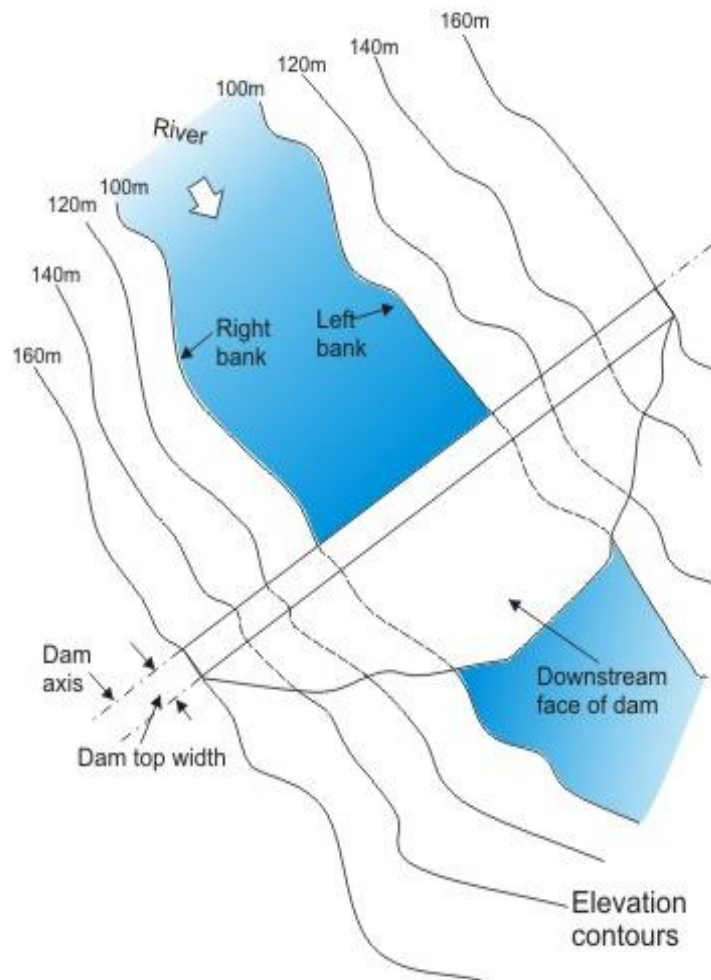

FIGURE 6. A typical layout of a concrete gravity dam in plan.

If a concrete gravity dam is appreciably more than 20 m in length measured along the top of the dam from one bank of the river valley to the other, then it is necessary to divide the structure into blocks by providing **transverse contraction joints**. These joints are in vertical planes that are at the right angle to the dam axis and separated about 18-20 m. The spacing of the joints is determined by the capacity of the concreting facilities to be used and considerations of volumetric changes and attendant cracking caused by shrinkage and temperature variations. The possibilities of detrimental cracking can be greatly reduced by the selection of the proper type of the cement and by careful control of mixing and placing procedures. The contraction joints allow relieving of the thermal stresses. In plan, therefore the concrete gravity dam layout would be as shown in Figure 7, where the dam is seen to be divided into blocks separated by the contraction joints.



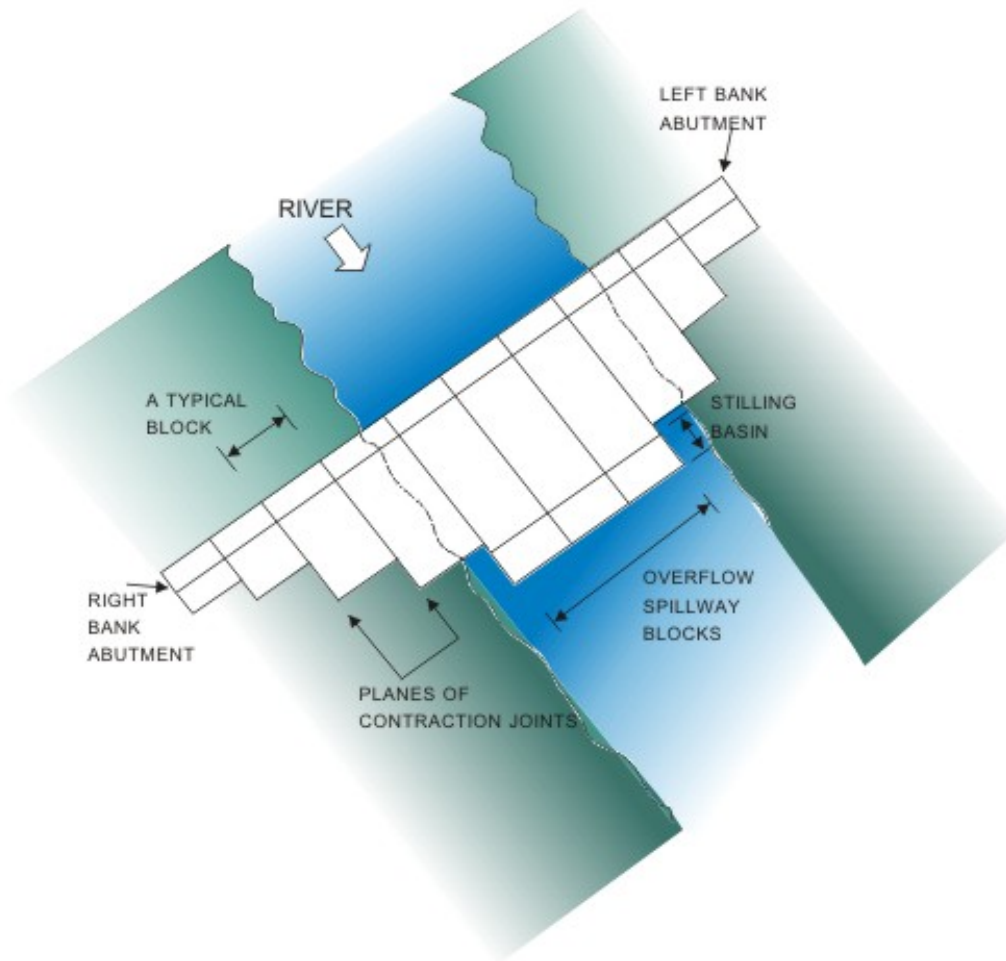

FIGURE 7. Layout of blocks for concrete gravity dams.

The base of each block of the dam is horizontal and the blocks in the centre of the dam are seen to accommodate the spillway and **energy dissipators**. The blocks with maximum height are usually the spillway blocks since they are located at the deepest portion of the river gorge, as shown in Figure 7. The upstream face of the dam is sometimes made inclined (Figure 8a) or kept vertical up to a certain elevation and inclined below (Figure 8b).

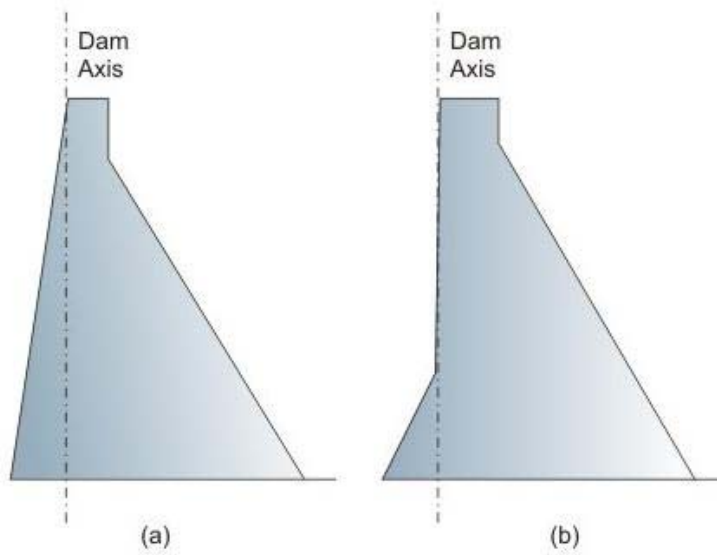

FIGURE 8. Upstream inclined face for concrete gravity dams. (a) Full face inclined; (b) Partly inclined

In plan, the dam axis may be curved as for the **Indira Sagar Dam** (Figure 9), but it does not provide any arch action since each block is independent being separated by a construction joint.

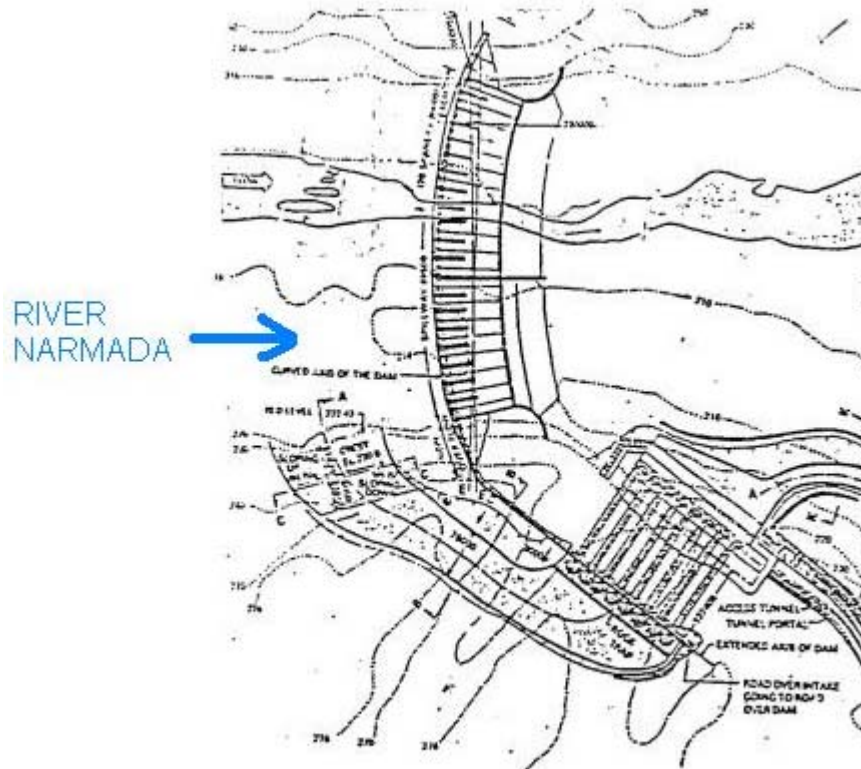

FIGURE 9. Indira Sagar dam curved layout

The construction joints in a concrete gravity dams provide passage through the dam which unless sealed, would permit the leakage of water from the reservoir to the downstream face of the dam. To check this leakage, water stops are installed in the joints adjacent to the upstream face (Figure 10).

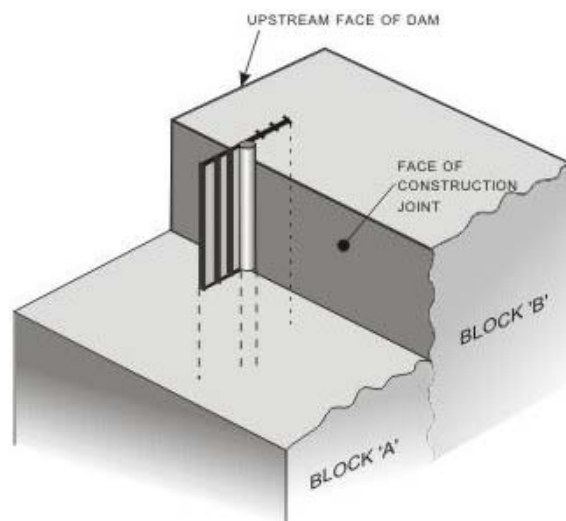

FIGURE 10. Typical installation of a water stop near upstream face of dam

Not very long ago, different types of water – stops were being used like copper strips, asphalt grouting, etc. apart from rubber seals. However, unsatisfactory performance of the copper strips and asphalt seals and advancement in the specifications and indigenous manufacture of good quality Polyvinyl Chloride (PVC) water stops have led to the acceptance of only the PVC water stops for all future dam construction. This has been recommended by the following Bureau of Indian Standard codes:

- IS 12200-2001 “Provision of water stops at transverse construction joints in masonry and concrete dams- code of practice”
- IS 15058-2002 “ PVC water stops at transverse construction joints in masonry and concrete dams- code of practice”

The recommended cross section of a PVC water stop is shown in Figure 11.

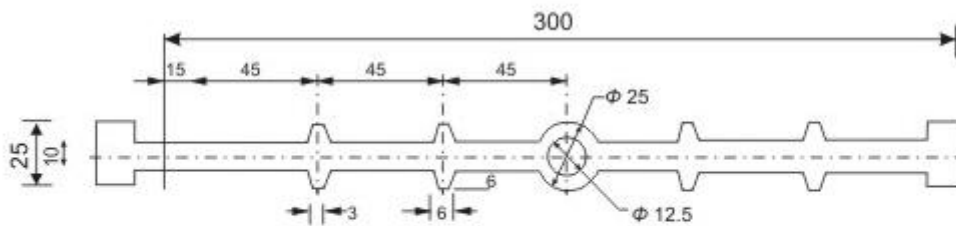

FIGURE 11. Cross section of a PVC water stop  
(All dimensions are in mm)

According to the recommendations of IS 1220-2001, there needs to be more than one layer of PVC water stop at each joint between two blocks, as shown in Figure 12

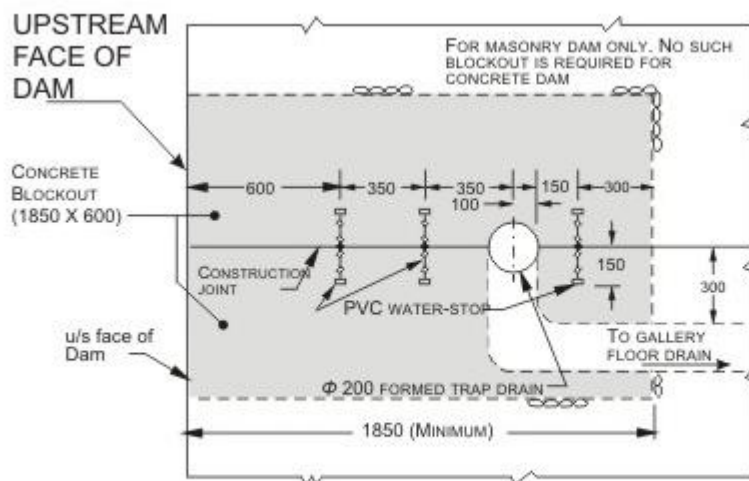

FIGURE 12. Sectional plan through two adjacent blocks showing relative placement of PVC water stops. Note the formed trap drain for removing any leakage water

In the vertical plane, the water stop needs to continue right up to the elevation of the maximum water level plus at least 1000 mm as shown in Figures 13 and 14.

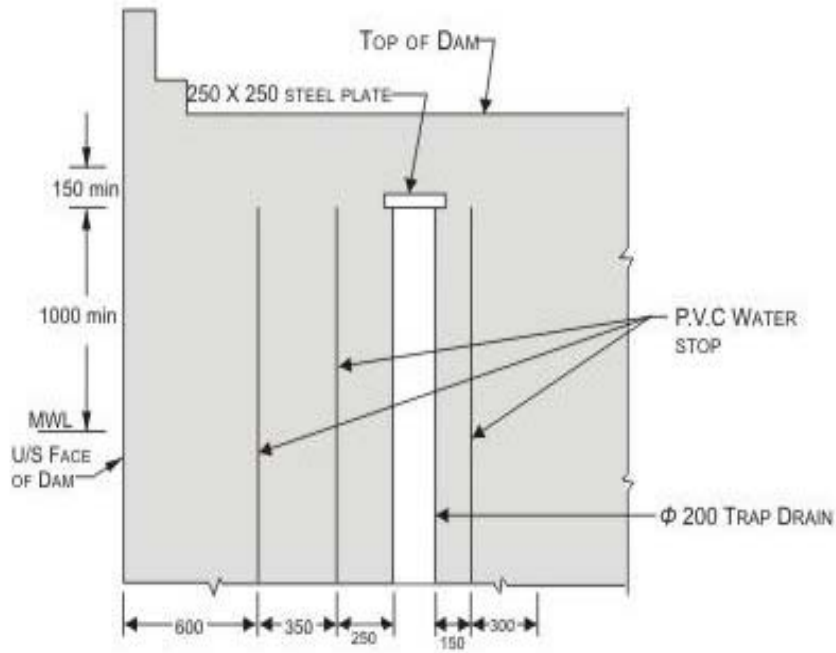

FIGURE 13. Water stop details near top of non-overflow section of concrete gravity dam. The formed trap drain also extends upto the same elevation as water stops.

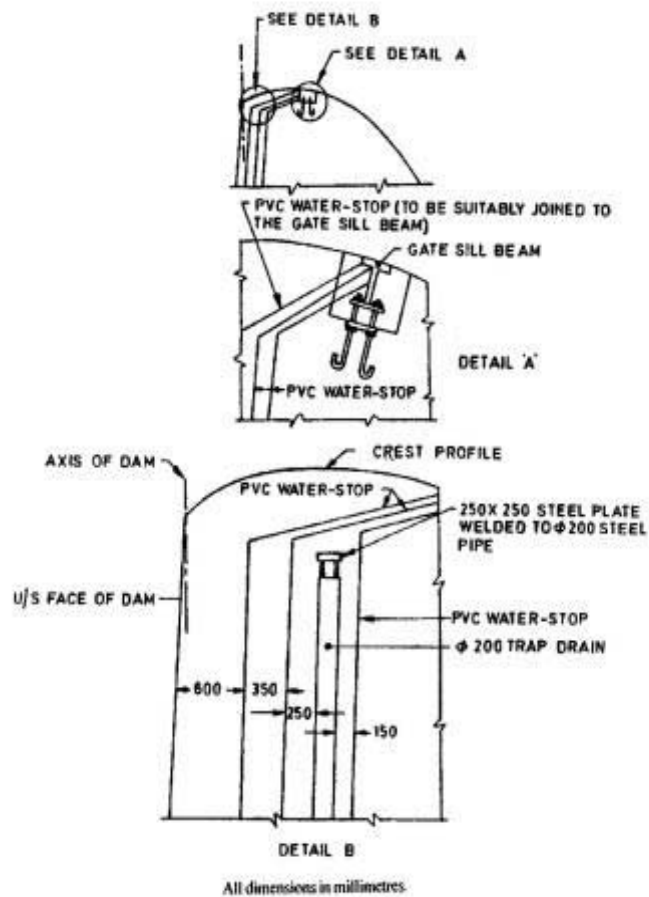

FIGURE 14. Water stop details near top of the crest of spillway (overflow) section of a concrete gravity dam.

In spite of the provision of water stops there may be leakage through the body of the dam due to the pressure of water from the upstream. In order to remove this water, vertical formed drains to trap the seeping water through the contraction joint is recommended as may be observed from Figures 12 to 13. These vertical drains convey the drainage water to a drainage gallery at some lower level within the dam body as shown in Figure 15.

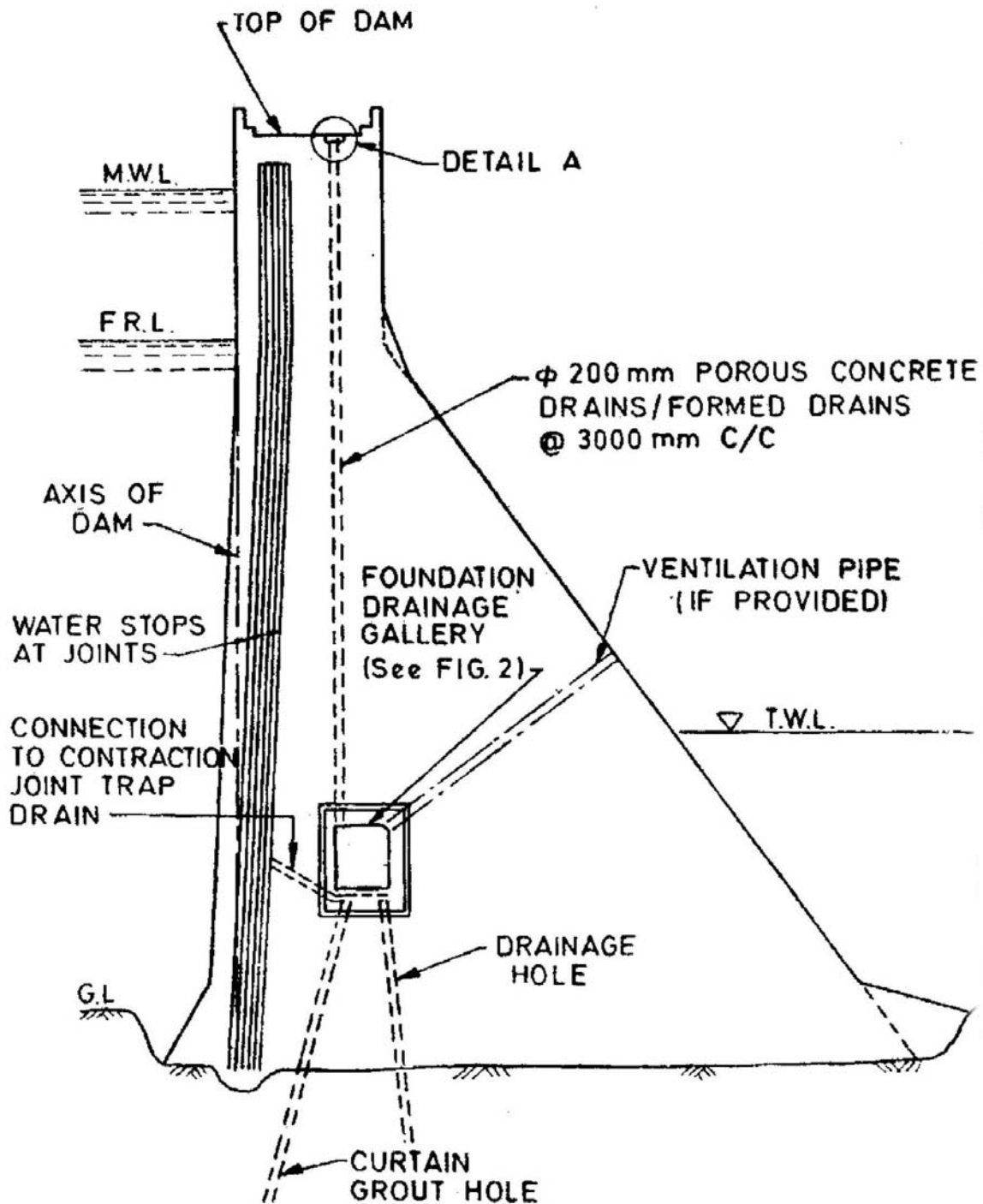

FIGURE 15. Vertical formed drain connected to drainage gallery.

It may be noticed that the formed drain is provided not only at the transverse contraction joint between two adjacent blocks of a concrete gravity dam, they are placed at an

equal interval of about 3metres centre to centre in all the dam blocks, as recommended by the Bureau of Indian Standard code IS 10135-1985” Code of practice for drainage system for gravity dams, their foundations and abutments”.

These drains are required to intercept any seeping water from the reservoir through the upstream face of the concrete dam. The vertical drains may be formed drains or may be filled with porous concrete, which is formed by mixing 1 part cement with 5 parts of 5 to 20 mm size aggregates. It is also recommended in IS 10135 that the permeability of a 200 mm thick slab of this concrete under a head of 100 mm should be such that the discharge should not be less than 30litres/min/m<sup>2</sup>. It is important to note that the general mass concrete of a dam, though not as porous as the lean concrete mentioned above also seeps water but to a very lesser quantity.

The foundation drainage gallery (shown in Figure 15) is connected to all the vertical drains passing through the body of the dam (Figure 16).

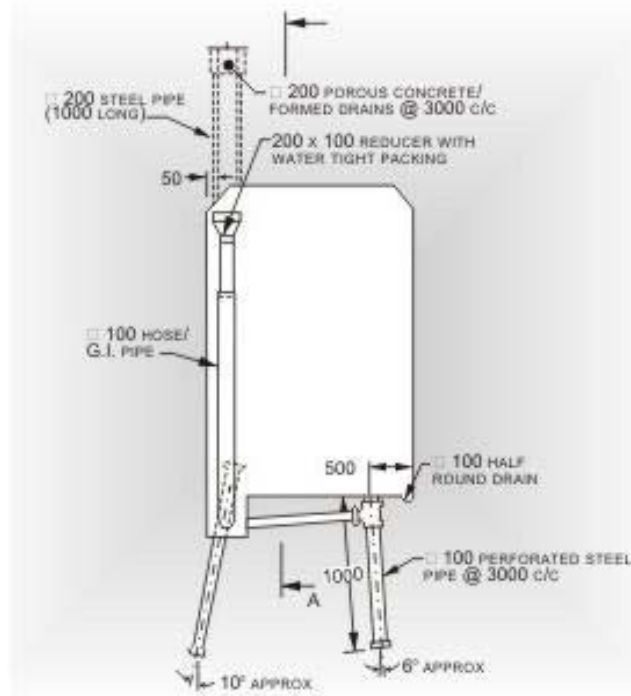

FIGURE 16. Details of a foundation drainage gallery

This gallery, of a size large enough for a person to walk comfortably, extends throughout the length of the dam at about the same height above.



In plan the gallery is near and parallel to the axis of the dam. The dam foundation is as shown in Figure 17.

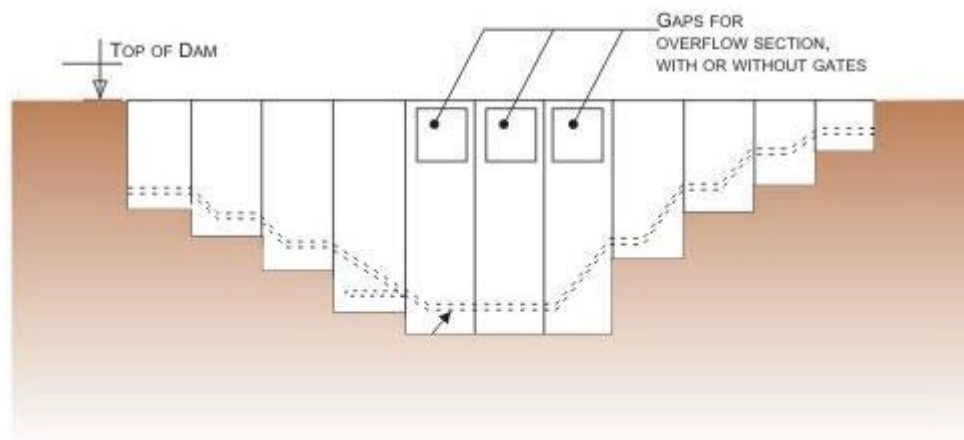

FIGURE 17. Alignment of drainage gallery shown in an elevation view of a concrete gravity dam

The foundation drainage gallery should have a small slope, about 1 in 1000 to drain away the collected water in the side drain up to a sump at the lowest level from where the water may be pumped out to the downstream side of the dam. As such, it is compulsorily recommended to provide a drainage gallery whose normal foundation level is more than 10metres measured from the crest level of the overflow portion of the dam. For dams with maximum height less than 10metres between the deepest foundation level and the overflow section crest level, the provision of a drainage gallery is optional.

Another important location of water seeping through is the bottom of a concrete gravity dam. This water seeps through the foundation material, like through the joints of a fractured rock upon which the dam is founded. This seepage water also causes uplift at the base of the dam and produces an upward force that must be countered by the weight of the dam apart from countering other forces discussed in the next section. Thus drainage of foundation material is an important consideration in concrete dam design.

It may be observed from the details of a foundation drainage gallery that 100mm diameter perforated steel pipes are usually provided through the floor of the gallery that penetrates into the foundation. These drainage holes are drilled once the foundation gallery base has been constructed and the foundation grouting (explained later) is completed. The size, spacing and the depth of these holes are assumed on the basis of physical characteristics of the foundation rock, foundation condition and the depth of the

storage reservoir. The diameter of the hole may be kept at 75mm and the spacing of holes may be kept at 3m centre to centre. The depth of holes may be kept between 20 and 40 percent of the maximum reservoir depth and between 30 and 75 percent depth of the curtain grouting (explained later). The drainage holes of 75mm diameter are drilled through 100 mm diameter pipe embedded in concrete portion of the dam. For foundation drainage holes in soft foundation, the arrangement shown in Figure 18 may be adopted.

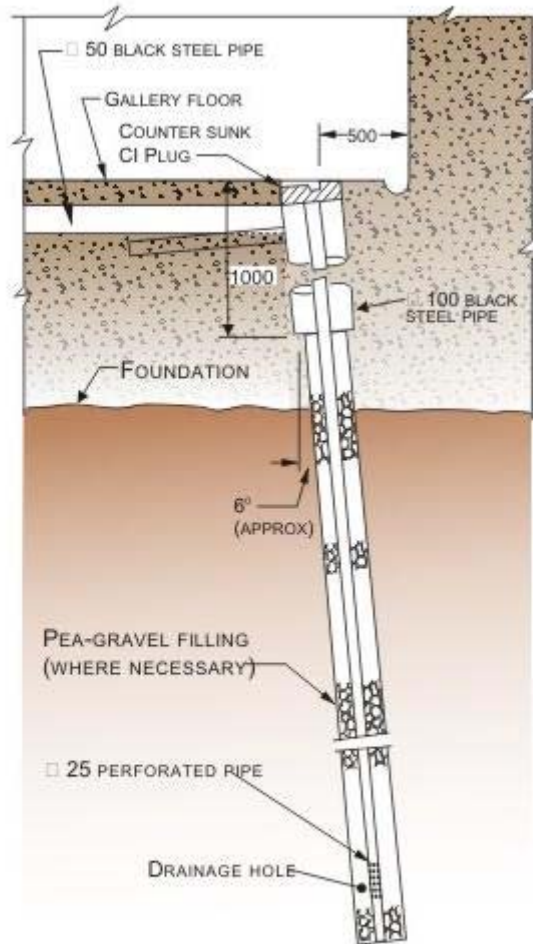

FIGURE 18. Details of foundation drainage gallery in soft foundation

Another function of the foundation gallery is to provide a space for drilling holes for providing what is called grout curtain, which is nothing but a series of holes drilled in a line deep inside the foundation and filled with pressurized cement mortar. The location of a grout hole within a foundation gallery may be seen from Figure 16. The purpose of providing these holes and injecting them with cement mortar is to create a barrier in the foundation rock at the heel of the dam (Figure 19) which will prevent leakage of water from the reservoir and thus reduce uplift pressure at the bottom of the dam.

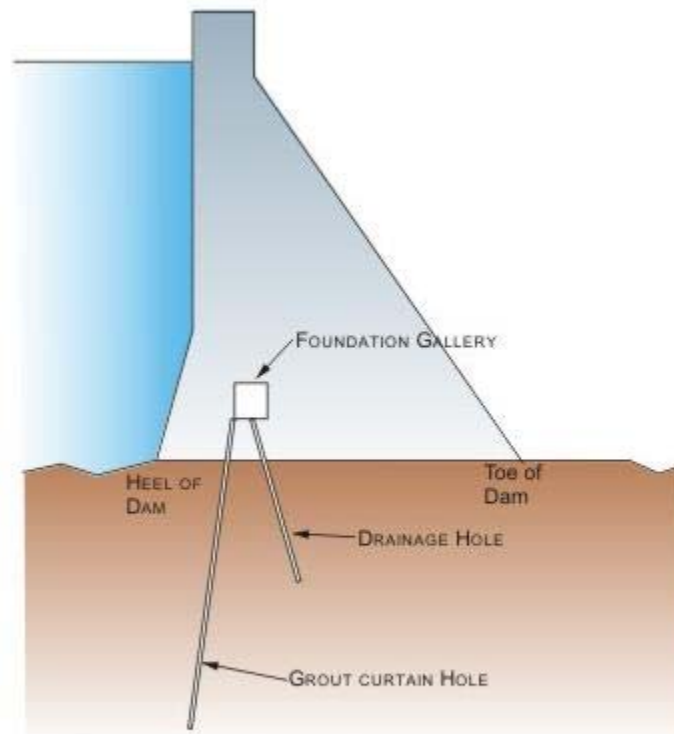

FIGURE 19. Drainage and grout curtain holes

The depth of the grout curtain holes depends upon the nature of the rock in foundation and in general, it may range from 30 to 40 percent of the head of the water on good foundation and to 70 percent of head on poor foundations.

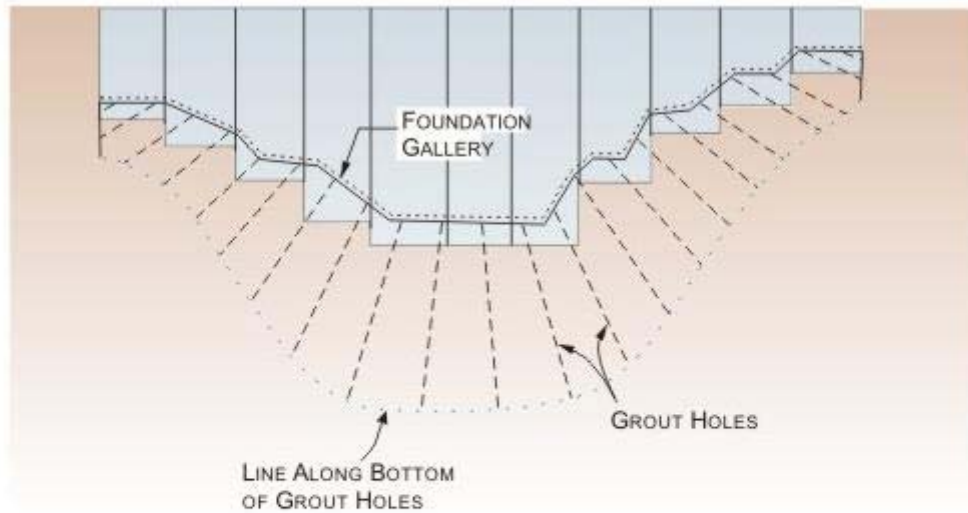

FIGURE 20. Series of grout holes forming a grout curtain shown in elevation of a concrete gravity dam

Figure 20 shows a typical layout of grout holes for a concrete gravity dam shown in an elevation view.

According to IS: 11293 (Part2)-1993 “Guidelines for the design of grout curtains”, the following empirical criteria may be used as a guide:

$$D = \left(\frac{2}{3}\right) H + 8 \quad (1)$$

Where **D** is the depth of the grout curtain in meters and **H** is the height of the reservoir water in meters.

The grout holes may be either vertical or inclined.

The orientation, plan and inclination of grout holes depend upon the type of joints and the other discontinuities in the foundation rock. The most common practice is to drill holes inclined towards the upstream at 5 to 10 degrees to the vertical.

Apart from the gallery at the foundation level, there could be other galleries located at intermediate levels as shown Figures 21 and 22.

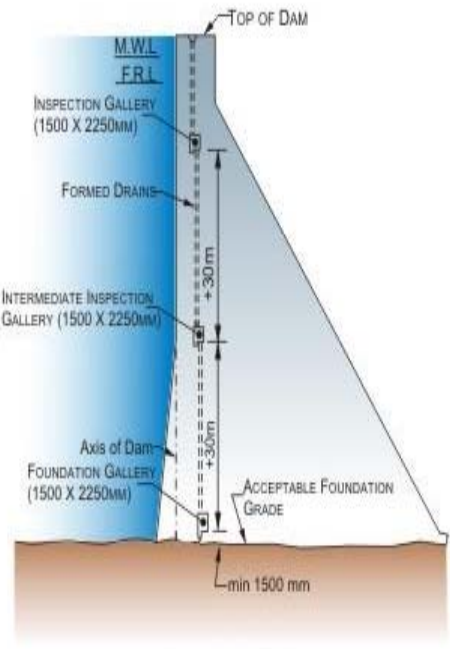

FIGURE 21. Galleries in a non-overflow section of a typical concrete gravity dam.

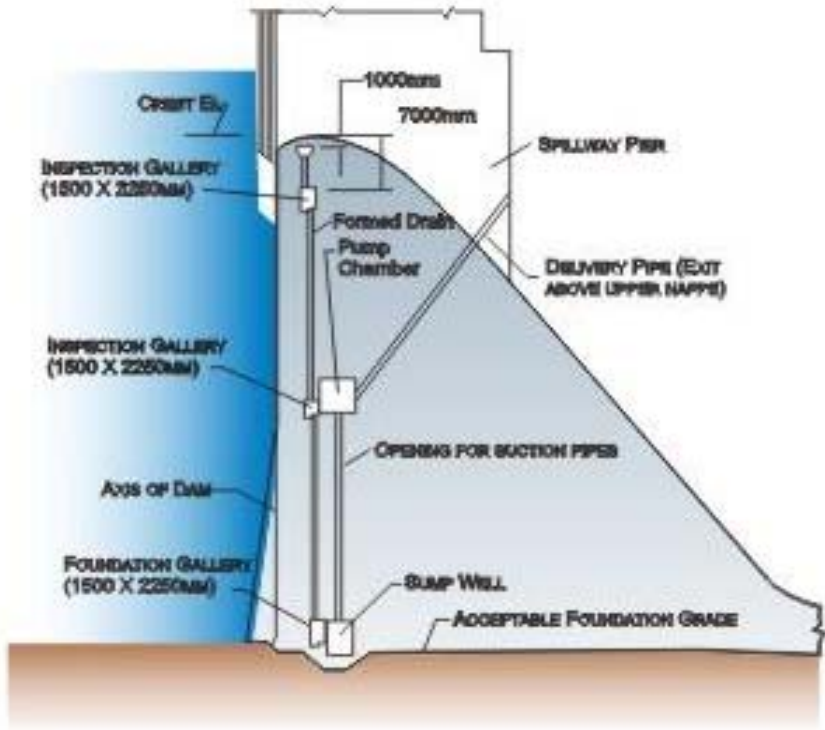

FIGURE 22: Galleries in a overflow-section of a typical concrete gravity dam

At times, gate galleries have to be provided in a dam to give access to and room for the mechanical and electrical equipment required for the operation of gates in outlet conduits, penstocks, etc. Inspection galleries are also sometimes provided to give access to the interior mass of the dam after completion. Foundation, drainage and gate galleries also serve as inspection galleries. In order to connect these galleries that are parallel to the dam axis, transverse galleries called adits are also provided in a dam. Adits providing access to the galleries from outside the dam are also called access gallery or entrance gallery.

It may be interesting to note that all spillways of dams (including gravity dams) may not be necessarily be gated. Ungated spillways have been provided in dams located in remote areas where spillway operation by manual control is difficult. For the gated spillways, radial gates are more common nowadays, though vertical lift gates have been used in some dams earlier. More details about gates and hoists have been presented in a subsequent lesson.

Apart from the openings in dams discussed earlier sluices are also provided in the body of the dam to release regulated supplies of water for a variety of purposes. Details about the types of sluices and their uses are provided separately.

Sometimes the non overflow blocks of a concrete gravity dams are used to accommodate the penstocks (large diameter pipes) which carry water from the reservoir to the powerhouse. Design of the intakes and conveyance systems for power generation have been discussed in another lesson.

## 4.6.2 Design of concrete gravity Dam sections

Fundamentally a gravity dam should satisfy the following criteria:

1. It shall be safe against overturning at any horizontal position within the dam at the contact with the foundation or within the foundation.
2. It should be safe against sliding at any horizontal plane within the dam, at the contact with the foundation or along any geological feature within the foundation.
3. The section should be so proportional that the allowable stresses in both the concrete and the foundation should not exceed.

Safety of the dam structure is to be checked against possible loadings, which may be classified as primary, secondary or exceptional. The classification is made in terms of the applicability and/or for the relative importance of the load.

1. Primary loads are identified as universally applicable and of prime importance of the load.
2. Secondary loads are generally discretionary and of lesser magnitude like sediment load or thermal stresses due to mass concreting.
3. Exceptional loads are designed on the basis of limited general applicability or having low probability of occurrence like inertial loads associated with seismic activity.

Technically a concrete gravity dam derives its stability from the force of gravity of the materials in the section and hence the name. The gravity dam has sufficient weight so as to withstand the forces and the overturning moment caused by the water impounded in the reservoir behind it. It transfers the loads to the foundations by cantilever action and hence good foundations are pre requisite for the gravity dam.

The forces that give stability to the dam include:

1. Weight of the dam
2. Thrust of the tail water

The forces that try to destabilize the dam include:

1. Reservoir water pressure
2. Uplift
3. Forces due to waves in the reservoir
4. Ice pressure
5. Temperature stresses
6. Silt pressure
7. Seismic forces
8. Wind pressure

The forces to be resisted by a gravity dam fall into two categories as given below:

1. Forces, such as weight of the dam and water pressure which are directly calculated from the unit weight of materials and properties of fluid pressure and
2. Forces such as uplift, earthquake loads, silt pressure and ice pressure which are assumed only on the basis of assumptions of varying degree of reliability. In fact to evaluate this category of forces, special care has to be taken and reliance placed on available data, experience and judgement.

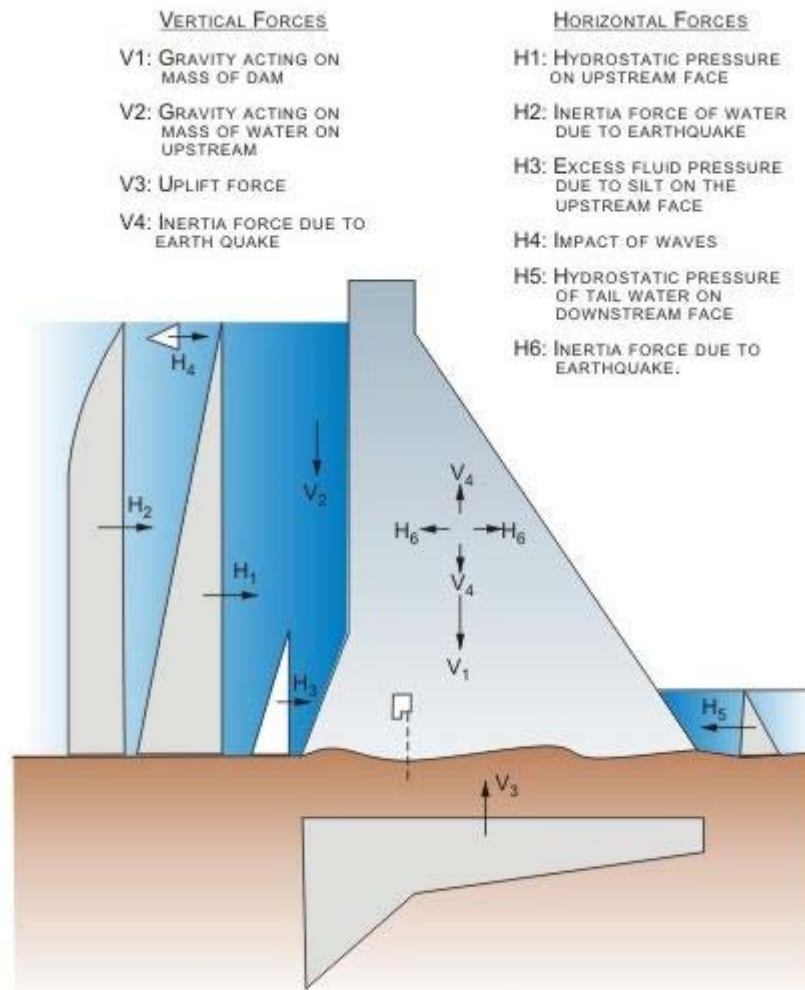

FIGURE 23: Different forces acting on a concrete gravity dam

Figure 23 shows the position and direction of the various forces expected in a concrete gravity dam. Forces like temperature stresses and wind pressure have not been shown. Ice pressures being uncommon in Indian context have been omitted.

For consideration of stability of a concrete dam, the following assumptions are made:

1. That the dam is composed of individual transverse vertical elements each of which carries its load to the foundation without transfer of load from or to adjacent elements. However for convenience, the stability analysis is commonly carried out for the whole block.
2. That the vertical stress varies linearly from upstream face to the downstream face on any horizontal section.

The Bureau of Indian Standards code IS 6512-1984 “Criteria for design of solid gravity dams” recommends that a gravity dam should be designed for the most adverse load condition of the seven given type using the safety factors prescribed.



Depending upon the scope and details of the various project components, site conditions and construction programme one or more of the following loading conditions may be applicable and may need suitable modifications. The seven types of load combinations are as follows:

1. Load combination A (construction condition): Dam completed but no water in reservoir or tailwater
2. Load combination B (normal operating conditions): Full reservoir elevation, normal dry weather tail water, normal uplift, ice and silt (if applicable)
3. Load combination C: (Flood discharge condition) - Reservoir at maximum flood pool elevation, all gates open, tailwater at flood elevation, normal uplift, and silt (if applicable)
4. Load combination D: Combination of A and earthquake
5. Load combination E: Combination B, with earthquake but no ice
6. Load combination F: Combination C, but with extreme uplift, assuming the drainage holes to be Inoperative
7. Load combination G: Combination E but with extreme uplift (drains inoperative)

It would be useful to explain in a bit more detail the different loadings and the methods required to calculate them. These are explained in the following sections.

### 4.6.3 Loadings for concrete Gravity Dams

The significant loadings on a concrete gravity dam include the self-weight or dead load of the dam, the water pressure from the reservoir, and the uplift pressure from the foundation. There are other loadings, which either occur intermittently, like earthquake forces, or are smaller in magnitude, like the pressure exerted by the waves generated in the reservoir that is the upstream of the dam face. These loadings are explained in the following section.

#### 4.6.3.1 Dead load

The dead load comprises of the weight of the concrete structure of the dam body in addition to pier gates and bridges, if any over the piers. The density of concrete may be considered as  $2400 \text{ kg/m}^3$ . Since the cross section of a dam usually would not be simple, the analysis may be carried out by dividing the section into several triangles and rectangles and the dead load (self weight) of each of these sections (considering unit width or the block width) computed separately and then added up. For finding out the moment of the dead load (required for calculating stresses), the moments due to the separate sub-parts may be calculated individually and then summed up.

#### 4.6.3.2 Water pressure on dam

The pressure due to water in the reservoir and that of the tailwater acting on vertical planes on the upstream and downstream side of the dam respectively may be calculated by the law of hydrostatics. Thus, the pressure at any depth  $h$  is given by  $\gamma h$   $\text{kN/m}^2$  acting normal to the surface. When the dam has a sloping upstream face, the

water pressure can be resolved into its horizontal and vertical components, the vertical component being given by the weight of the water prism on the upstream face and acts vertically downward through the centre of gravity of the water area supported on the dam face.

In spillway section, when the gates are closed, the water pressure can be worked out in the same manner as for non-overflow sections except for vertical load of water on the dam itself. During overflow, the top portion of the pressure triangle gets truncated and a trapezium of pressure acts (Figure 24).

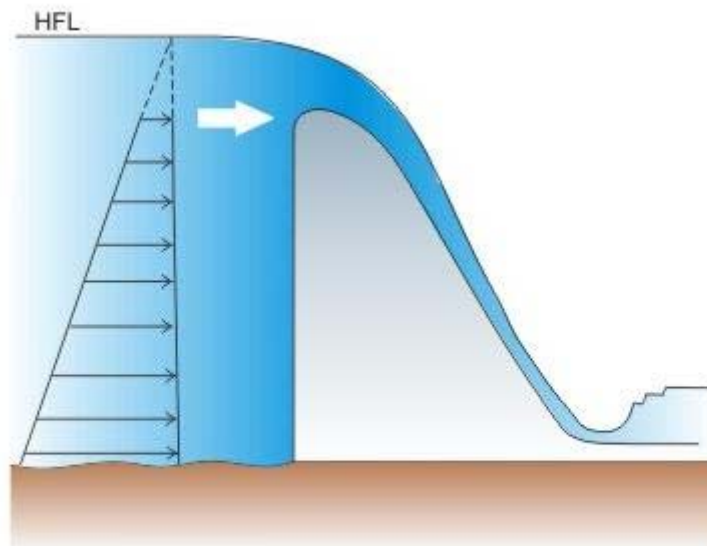

FIGURE 24. Horizontal water force on spillway block during flood water overflow

The pressure due to tailwater is obtained in a similar manner as for the upstream reservoir water.

In case of low overflow dams, the dynamic effect of the velocity of approach may be significant and deserve consideration.

#### **4.6.3.3 Uplift pressures**

Uplift forces occur as internal pressure in pores, cracks and seams within the body of the dam, at the contact between the dam and its foundation and within the foundation. The recent trends for evaluating uplift forces is based on the phenomenon of seepage through permeable material. Water under pressure enters the pores and fissures of the foundation material and joints in the dam. The uplift is supposed to act on the whole width plane, that is being considered, either at the base or at any position within the dam. The uplift pressure on the upstream end of the considered horizontal plane is taken as  $\gamma h_u$  where  $h_u$  is the depth of water above the plane. On the downstream the value is  $\gamma h_d$  where  $h_d$  is again the depth of water above the plane.

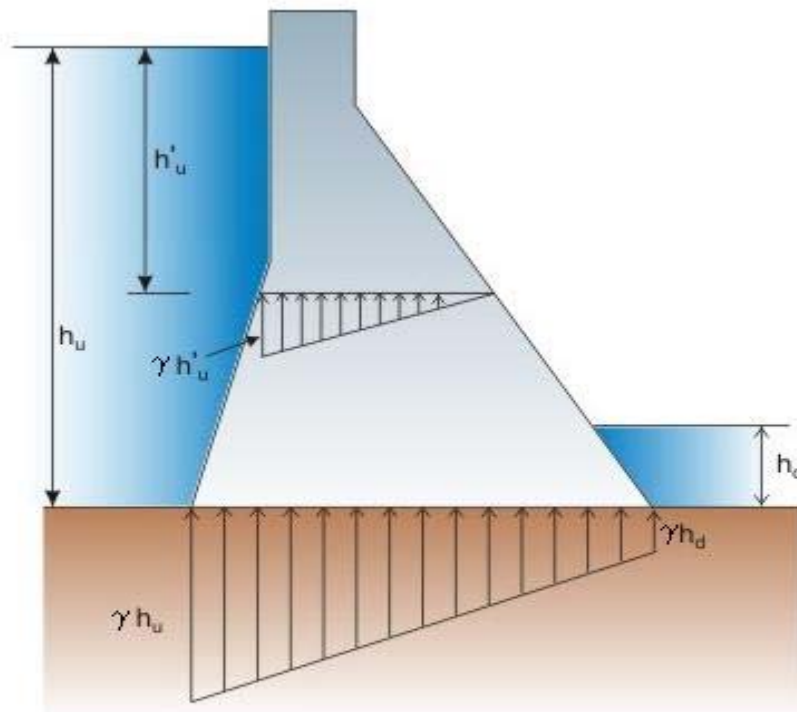

FIGURE 25. Uplift pressure at base and at any general plane in the dam body. Drainage holes are not considered.

Figure 25 illustrates the uplift pressure on a concrete gravity dam's non overflow section through two planes – one at the base and the other at the horizontal plane which is above the tail water level. In Figure 25, the drainage holes either in the body of the dam, or within the foundation has not been considered. If the effects of the drainage holes are considered, then the uplift pressure diagram gets modified as shown in Figure 26. If there is crack at any plane of the dam, or at the base then the uplift pressure diagram gets further modified as shown in Figure27.

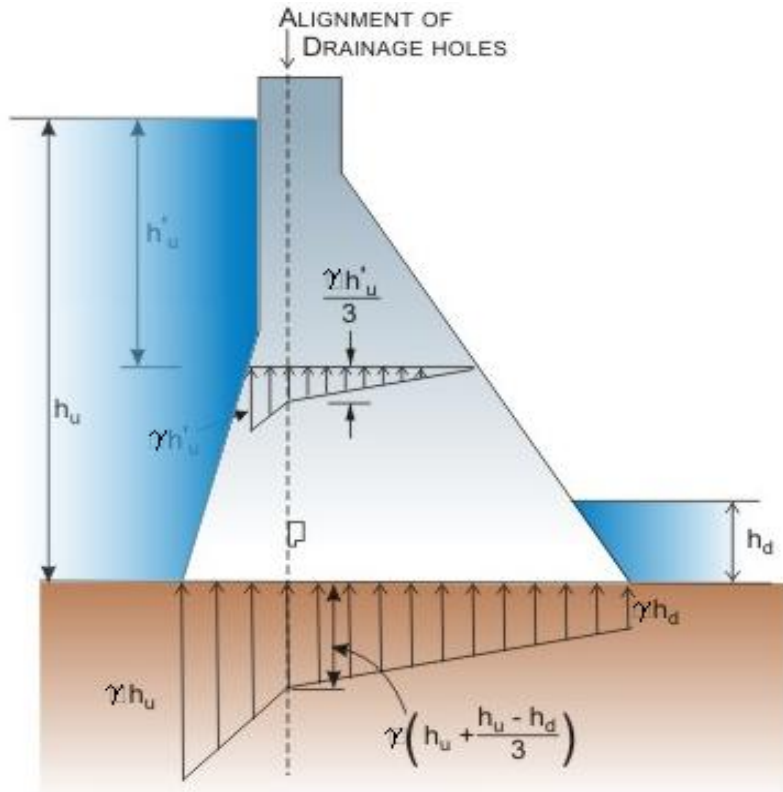

FIGURE 26: Assumed uplift pressure considering presence of drainage holes

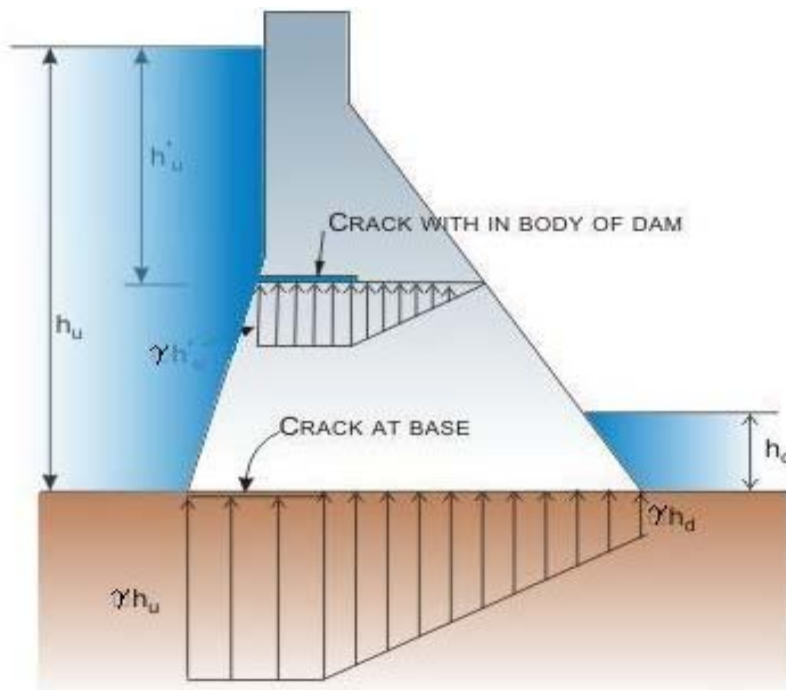

FIGURE 27: Uplift pressure diagrams considering horizontal cracks at any general plane/at the base.

As such, the uplift pressure is assumed to act throughout the base area. Further it is also assumed that they remain unaffected by earthquakes.

#### **4.6.3.4 Silt pressure**

The weight and the pressure of the submerged silt are to be considered in addition to weight and pressure of water. The weight of the silt acts vertically on the slope and pressure horizontally, in a similar fashion to the corresponding forces due to water. It is recommended that the submerged density of silt for calculating horizontal pressure may be taken as  $1360 \text{ kg/m}^3$ . Equivalently, for calculating vertical force, the same may be taken as  $1925 \text{ kg/m}^3$ .

#### **4.6.3.5 Earthquake (seismic) forces**

Earthquake or seismic activity is associated with complex oscillating patterns of acceleration and ground motions, which generate transient dynamic loads due to inertia of the dam and the retained body of water. Horizontal and vertical accelerations are not equal, the former being of greater intensity.

The earthquake acceleration is usually designated as a fraction of the acceleration due to gravity and is expressed as  $\alpha \cdot g$ , where  $\alpha$  is the **Seismic Coefficient**. The seismic coefficient depends on various factors, like the intensity of the earthquake, the part or zone of the country in which the structure is located, the elasticity of the material of the dam and its foundation, etc. For the purpose of determining the value of the seismic coefficient which has to be adopted in the design of a dam, India has been divided into five seismic zones, depending upon the severity of the earthquakes which may occur in different places. A map showing these zones is given in the Bureau of Indian Standards code IS: 1893-2002 (Part-1) "Criteria for earthquake resistant design of Structures (fourth revision)", and has been reproduced in Figure 28.

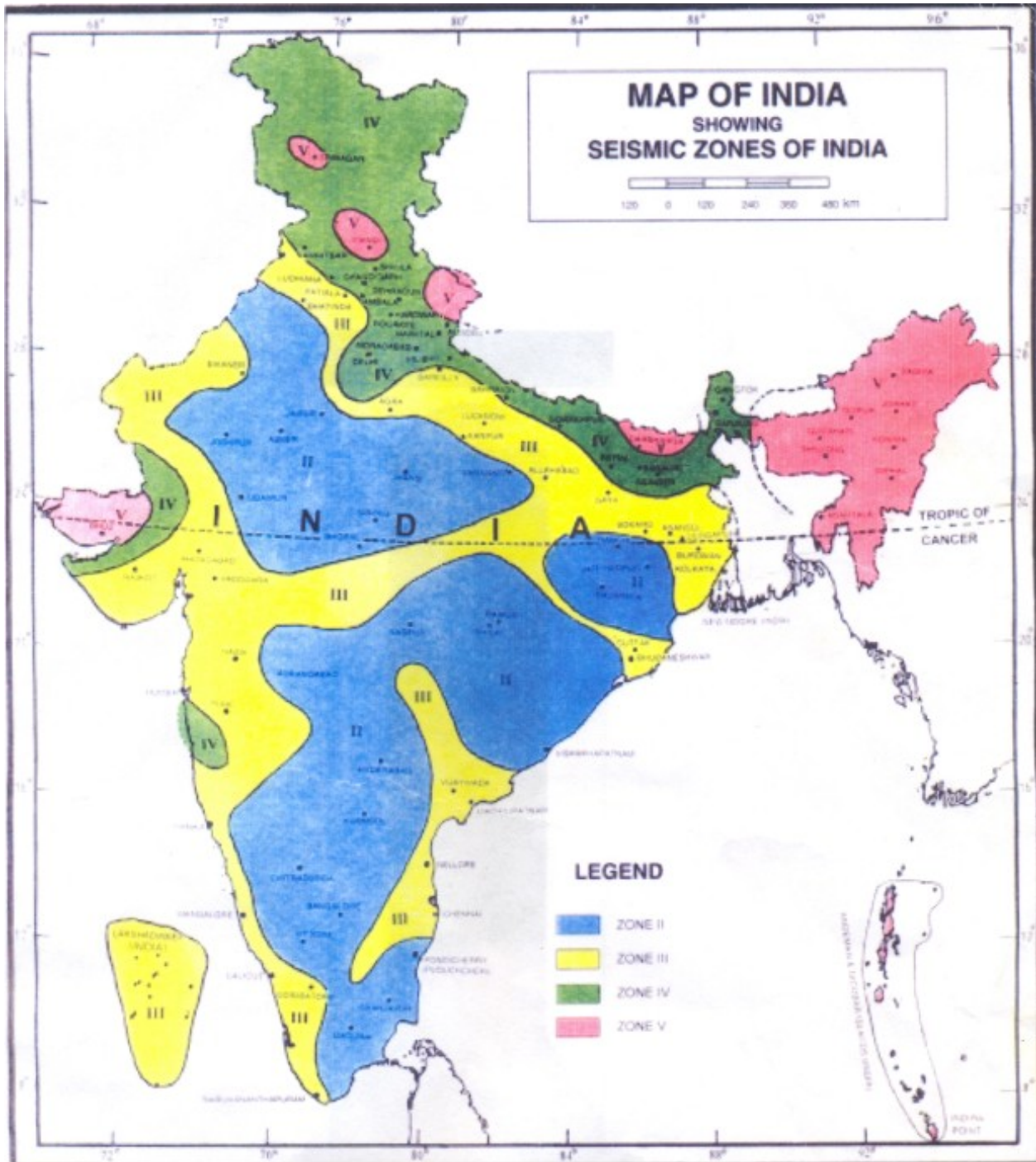

FIGURE 28. Seismic zones of India as per IS : 1893 - 2002 (Part 1)

The BIS code also indicates two methods that may be used for determining the coefficient  $\alpha$ .

These are:

1. The Seismic Coefficient Method (for dam height up to 100m)

$$\alpha = \beta I \alpha_0 \quad (2)$$

2. The Response Spectrum Method (for dams taller than 100m)

$$\alpha = \beta I \Phi_0 (\Sigma \alpha / \gamma) \quad (3)$$

In the above expressions,

$\beta$  = Soil-foundation system factor, which may be taken as 1.0 for dams

$I$  = Importance factor, which may be taken as 2.0 for dams

$\alpha_0$  = The basic seismic Coefficient, the value of which for each of the five zones is given the following table:

| Zone | $\alpha_0$ |
|------|------------|
| I    | 0.01       |
| II   | 0.02       |
| III  | 0.04       |
| IV   | 0.05       |
| V    | 0.08       |

$F_0$  = The seismic Zone Factor for average acceleration spectra, the value of which for each of the five zones is given in the following table:

| Zone | F    |
|------|------|
| I    | 0.05 |
| II   | 0.10 |
| III  | 0.20 |
| IV   | 0.25 |
| V    | 0.40 |

$S_a/g$  = the average acceleration coefficient that has to be read from Figure 29, corresponding to the appropriate natural period of vibration and damping of the structure.

The natural (or fundamental) period of vibration of a gravity dam may be determined by the following expression:

$$T = 5.59 \frac{H^2}{B} \sqrt{\frac{\gamma_m}{gE_s}} \quad (4)$$

Where

$T$  = The natural period of vibration of the dam, in seconds

$H$  = The height of the dam, in m

$B$  = The base width of the dam, in m

$\gamma_m$  = Specific weight of the material with which the dam is constructed. For concrete dams, it may be taken as about  $26.5 \text{ kN/m}^3$

$g$  = Acceleration due to gravity ( $=9.8 \text{ m/s}^2$ )

$E_s$  = Modulus of elasticity of the dam material. For concrete dams, it may be taken as about  $32.5 \text{ GPa}$ .

Using the value obtained for the natural period of vibration ( $T$ ) of the dam, and assuming the recommended value of 5 percent damping, as per IS: 1893-1984, the value of  $(S_a/g)$  may be obtained from Figure 29, and the value of the seismic coefficient computed using the appropriate equation.

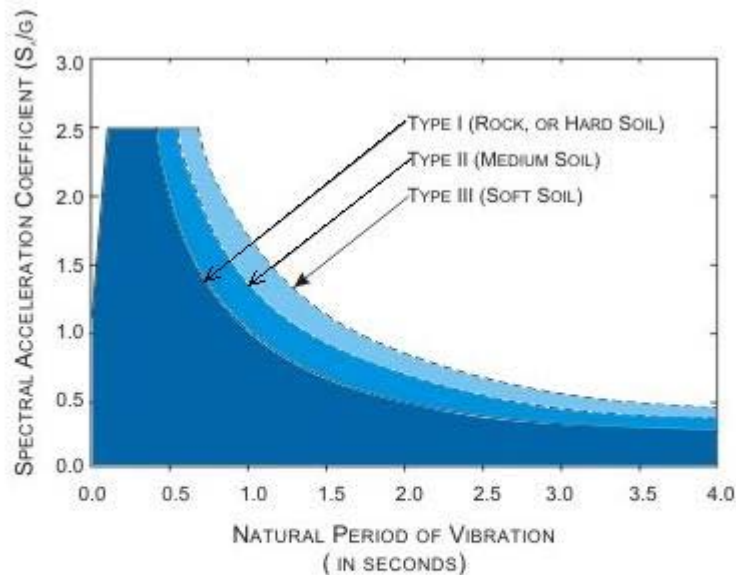

FIGURE 29. Average acceleration coefficient in terms of the natural period of vibration of the structure considering 5 percent damping. ( as per IS: 1893-2002, Part 1)

As mentioned earlier, the earthquake forces cause both the dam structure as well as the water stored in the reservoir to vibrate. The forces generated in the dam is called the Inertia Force and that in the water body, Hydrodynamic Force. Since the earthquake forces are generated due to the vibration of the earth itself, which may be shaking horizontally in the two directions as well as vibrating vertically. For design purpose, one has to consider the worst possible scenario, and hence the combination that is seen to be the least favourable to the stability of the dam has to be considered.



When the dam has been newly constructed, and the reservoir has not yet been filled, then the worst combination of vertical and horizontal inertia forces would have to be taken that cause the dam to topple backward as shown in Figure 30. The notations used in the figure are as follows:

- $H_u$ : Horizontal earthquake force acting in the upstream direction
- $H_D$ : Horizontal earthquake force acting in the downstream direction
- $V_u$ : Vertical earthquake force acting upwards
- $V_D$ : Vertical earthquake force acting downwards

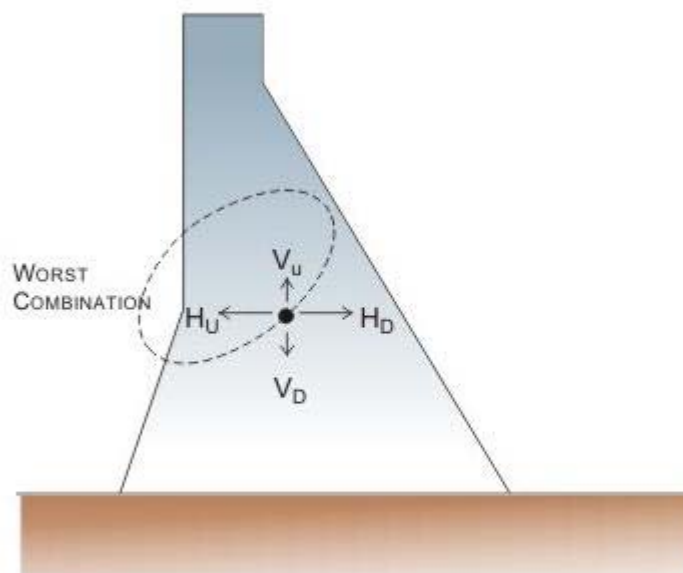

FIGURE 30. Worst combination of earthquake forces under reservoir empty condition

Under the reservoir full condition, the worst combination of the inertia forces is the one which tries to topple the dam forward, as shown in Figure 31.

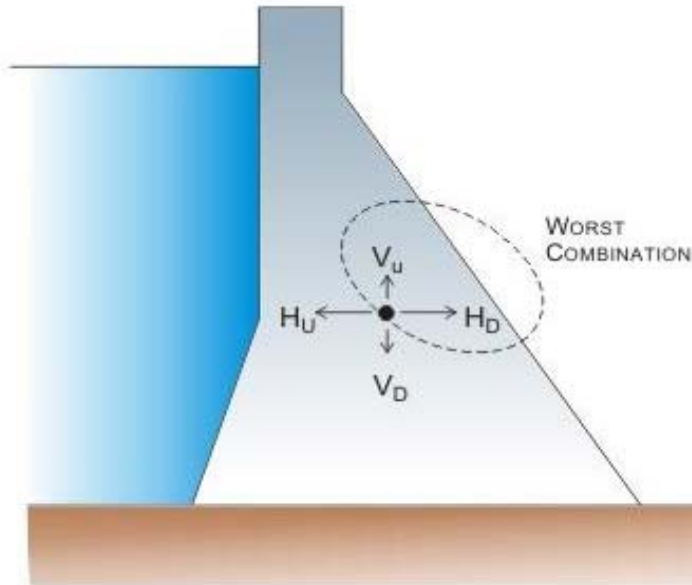

FIGURE 31. Worst combination of earthquake forces under reservoir full condition

In the Seismic Coefficient method, the horizontal and vertical acceleration coefficients,  $\alpha_h$  and  $\alpha_v$ , respectively, are assumed to vary linearly from base of the dam to its top as shown in Figure 32.

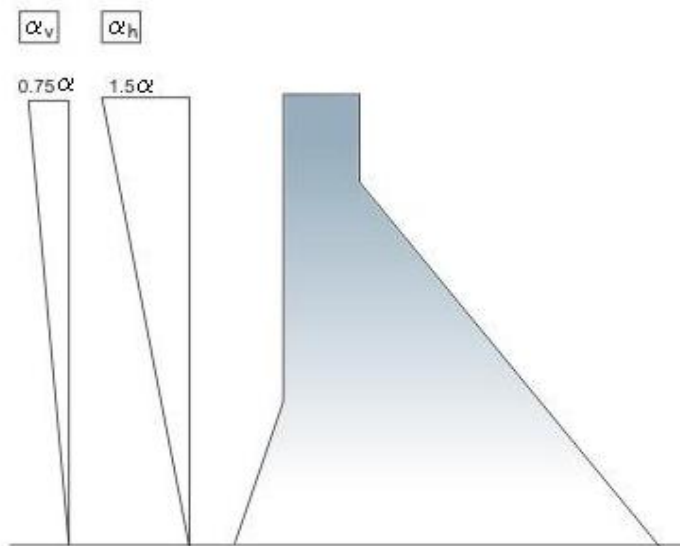

FIGURE 32. Variation of horizontal acceleration ( $\alpha_h$ ) and vertical acceleration ( $\alpha_v$ ) in terms of the Basic Seismic Coefficient  $\alpha$

In order to find the force generated due to the acceleration, it would be necessary to divide the dam into horizontal strips, finding out the force on each strip, and then integrating for the total dam height (Figure 33). This has to be done for both horizontal force **H** and vertical force **V**. Taking moment of these forces for each strip about any point in the dam body (say the heel or the toe) and integrating over the dam height would give the moment due to horizontal and vertical earthquake forces.

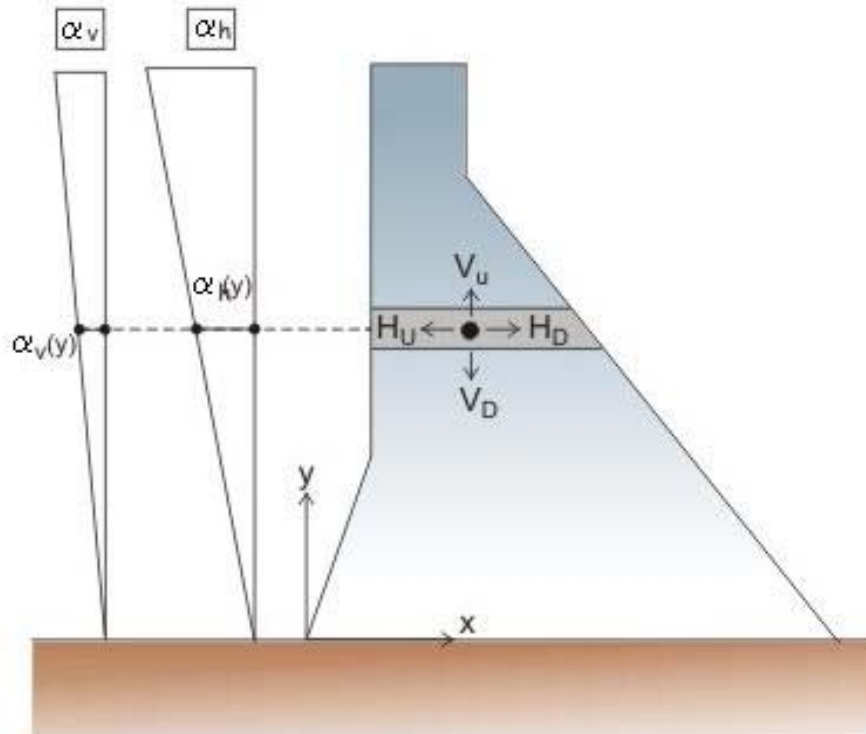

Figure 33. Earthquake acceleration forces in an infinitesimal horizontal strip in the body of the dam.

In the Response Spectrum method, the horizontal seismic coefficient  $\alpha_h$  is assumed to be equal to the value of the seismic coefficient  $\alpha$  obtained by the appropriate equation. The horizontal force  $H_B$  per unit length of the dam and its moment  $M_B$  about any point in the base of the dam is obtained by the following expressions:

$$H_B = 0.6W\alpha_h \quad (5)$$

$$M_B = 0.9W\bar{h}\alpha_h \quad (6)$$

Where

$W$  = Weight of the dam per unit length in KN/m

$\alpha_h$  = Seismic coefficient as obtained by the appropriate equation, and

$\bar{h}$  = Height of the centre of gravity of the dam above the base, in m.

For any horizontal section within the dam body, lying at a depth  $y$  from the top of the dam, the horizontal force  $H_y$  per unit length of the dam and the bending moment  $M_y$  may be obtained as follows:

$$H_y = C_H \cdot H_B \quad (7)$$

$$M_y = C_M \cdot M_B \quad (8)$$

Where  $C_H$  and  $C_M$  are coefficients that may be read out from Figure 34.

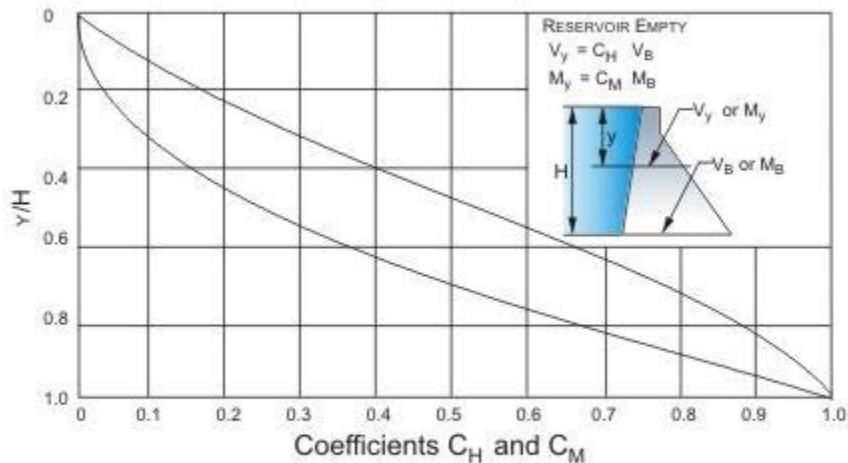

FIGURE.34: Variation of coefficients  $C_H$  and  $C_M$

As for the vertical earthquake force calculation by the Response Spectrum method, the vertical seismic coefficient  $\alpha_u$  has to be assumed to vary from zero at base up to  $0.75\alpha$  at the top, where  $\alpha$  is the seismic coefficient calculated appropriately. The method for calculating the vertical force and its corresponding moment has to proceed as for the seismic coefficient method.

The hydrodynamic pressure generated due to the horizontal movement of the water body in the reservoir and its consequent impinging against the dam may to be calculated by the following formula.

$$P = C_s \cdot \alpha \cdot \gamma \cdot h \quad (5)$$

Where

$P$  = Hydrodynamic pressure, in  $\text{KN/m}^2$  at any depth  $y$  below the reservoir surface

$C_s$  = Coefficient which varies with the shape of the dam and the depth of the reservoir, which may be found by the method indicated below

$\gamma$  = Unit weight of water, in  $\text{KN/m}^3$

$h$  = Total water depth in reservoir, in m

The variation of the coefficient  $C_s$  may approximately be found for a dam with vertical or constant upstream slope as:

$$C_s = \frac{C_m}{2} \left\{ \frac{y}{n} \left( 2 - \frac{y}{n} \right) + \sqrt{\frac{y}{n} \left( 2 - \frac{y}{n} \right)} \right\} \quad (6)$$

Where

$C_m$  = Maximum value of  $C_s$ , obtained from Figure 35

$y$  = Depth of horizontal section under consideration below the water surface, in m

$h$  = Total depth of water in reservoir

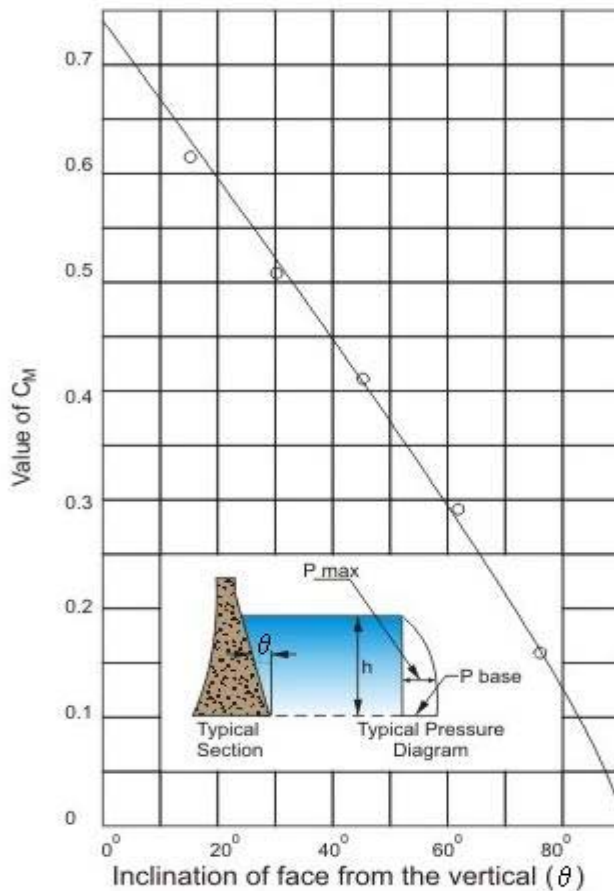

FIGURE.35: Maximum values of pressure coefficient ( $C_M$ ) for dams with constant sloping faces

For dams with combination of vertical and sloping faces, an equivalent slope may be used for obtaining the approximate value of  $C_s$ . If the height of the vertical portion of the upstream face of the dam is equal to or greater than one-half the total height of the dam, analyze it as if vertical throughout. If the height of the vertical portion of the upstream face of the dam is less than one-half the total height of the dam, use the pressure on the sloping line connecting the point of intersection of the upstream face of the dam and the reservoir surface with the point of intersection of the upstream face of the dam with the foundation.

The approximate values of horizontal pressure  $PH_y$  and moment due to the horizontal force  $MH_y$  due to hydrodynamic forces at any depth  $y$  (in m) below the reservoir surface is given by the following formulae.

$$PH_y = 0.726 \cdot p \cdot y \quad (\text{in KN per m length}) \quad (7)$$

$$MH_y = 0.299 \cdot p \cdot y \quad (\text{in KN.m per m length}) \quad (8)$$

Where  $p$  is the hydrodynamic pressure at any depth  $y$ .

If there is tail water on the downstream, then there would be appropriate hydrodynamic pressure on the downstream face of the dam.

### **Wave pressure**

The reservoir behind a dam is prone to generation of waves produced by the shearing action of wind blowing over the surface. Of course, the pressure of the waves against massive dams of appreciable height is not of much consequence. The height of wave is generally more important in determination of the free board requirements of dams to prevent overtopping of the dam crest by wave splash. The force and dimensions of waves depend mainly on the extent and dimensions of waves depend mainly on the extent and configuration of the surface area of the reservoir, the depth of the reservoir, and the velocity of the wind. The procedure to workout the height of waves generated, and consequently derive the safe free board, may be done according to the method described in IS: 6512-1984 "Criteria for design of solid gravity dams". However, since it is a bit involved, a simpler method is prescribed as that given by the Stevenson formula (Davis and Sorenson 1969).

$$H_w = 0.34\sqrt{F} + 0.76 - 0.26\sqrt[4]{F} \quad (9)$$

Where

$H_w$  = Height of wave, crest to trough, in m

$F$  = Fetch of the reservoir, that is, the longest straight distance of the reservoir from the dam up to the farthest point of the reservoir.

When the fetch exceeds 20Km, the above formula can be approximated as

$$H_w = 0.34\sqrt{F} \quad (10)$$

Since the height of the generated waves must be related to the wind velocity, the original formula has been modified to

$$H_w = 0.032\sqrt{(VF)} + 0.76 - 0.26^4\sqrt{F} \quad (11)$$

Where  $V$  = wind speed along the fetch, in km/h

Stevenson's approximate formula is applicable for wind speeds of about 100km/hour, which is a reasonable figure for many locations. It is conservative for low wind speeds but under estimates waves for high wind speeds.

The pressure intensity due to waves ( $P_w$ , in  $\text{KN/m}^2$ ) is given by the following expression

$$P_w = 23.544H_w \quad (12)$$

Where  $H_w$  is the height of wave in m. and occurs at  $1/8H_w$  above the still water level (Figure36).

The total wave pressure  $P_w$  per unit length (in  $\text{KN/m}$ ) of the dam is given by the area of the triangle 1-2-3 as given in Figure 36, and is given as

$$P_w = 20H_w^2 \quad (13)$$

The centre of application is at a height of  $0.375H_w$  above the still water level.

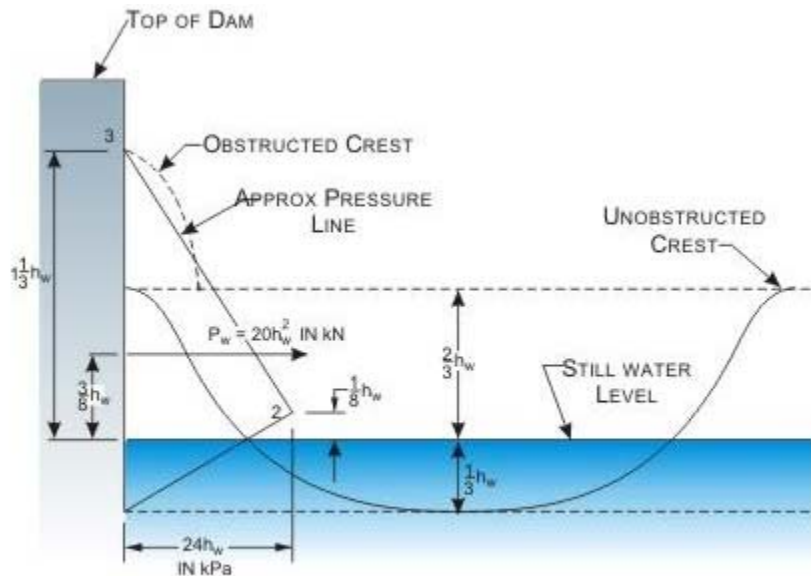

FIGURE. 36: Wave height, pressure and center of action

#### 4.6.4 Free board

Free board is the vertical distance between the top of the dam and the sill water level. IS:6512-1984 recommends that the free board shall be wind set-up plus 4/3 times wave height above normal pool elevation or above maximum reservoir level corresponding to design flood, whichever gives higher crest elevation. Wind set-up is the shear displacement of water towards one end of a reservoir by wind blowing continuously – or in repeated regular gusts – from one direction. The Zuider Zee formula (Thomas, 1976) and recommended by IS: 6512-1984 may be used as a guide for the estimation of set-up(S):

$$S = \frac{V^2 F \cos A}{kD} \quad (14)$$

Where

S = Wind set-up, in m

V = Velocity of wind over water in m/s

F = Fetch, in km

D = Average depth of reservoir, in m, along maximum fetch

A = Angle of wind to fetch, may be taken as zero degrees for maximum set-up

K = A constant, specified as about 62000

Set-up of the reservoir will depend upon the period of time over which the wind blows, that is, at least 1hour, for a fetch of 3km or 3hours for a fetch of 20km. On a 80km fetch, a wind speed of 80 km/hour must last for at least 4hours, whereas for a wind speed of 40km/hour it must last around 8hours for maximum set-up.

The free-board shall not be less than 1.0m above Maximum Water Level (MWL) corresponding to the design flood. If design flood is not same as Probable Maximum Flood (PMF), then the top of the dam shall not be lower than MWL corresponding to PMF.

#### 4.6.5 Stability analysis of gravity dams

The stability analysis of gravity dams may be carried out by various methods, of which the gravity method is described here. In this method, the dam is considered to be made up of a number of vertical cantilevers which act independently for each other. The resultant of all horizontal and vertical forces including uplift should be balanced by an equal and opposite reaction at the foundation consisting of the total vertical reaction and the total horizontal shear and friction at the base and the resisting shear and friction of the passive wedge, if any. For the dam to be in static equilibrium, the location of this force is such that the summation of moments is equal to zero. The distribution of the vertical reaction is assumed as trapezoidal for convenience only. Otherwise, the problem of determining the actual stress distribution at the base of a dam is complicated by the horizontal reaction, internal stress relations, and other theoretical considerations. Moreover, variation of foundation materials with depth, cracks and fissures which affect



the resistance of the foundation also make the problem more complex. The internal stresses and foundation pressures should be computed both with and without uplift to determine the worst condition.

The stability analysis of a dam section is carried out to check the safety with regard to

1. Rotation and overturning
2. Translation and sliding
3. Overstress and material failure

### ***Stability against overturning***

Before a gravity dam can overturn physically, there may be other types of failures, such as cracking of the upstream material due to tension, increase in uplift, crushing of the toe material and sliding. However, the check against overturning is made to be sure that the total stabilizing moments weigh out the de-stabilizing moments. The factor of safety against overturning may be taken as 1.5. As such, a gravity dam is considered safe also from the point of view of overturning if there is no tension on the upstream face.

### ***Stability against sliding***

Many of the loads on the dam act horizontally, like water pressure, horizontal earthquake forces, etc. These forces have to be resisted by frictional or shearing forces along horizontal or nearly-horizontal seams in foundation. The stability of a dam against sliding is evaluated by comparing the minimum total available resistance along the critical path of sliding (that is, along that plane or combination of plans which mobilizes the least resistance to sliding) to the total magnitude of the forces tending to induce sliding.

### NOTATION

$\Sigma H$  : NET HORIZONTAL FORCE

$\Sigma V$  : NET VERTICAL FORCE

$\alpha$  : INCLINATION OF INTERFACE OF DAM FOUNDATION

$C$  : COHESION OF MATERIAL AT THE PLANE

$A$  : AREA OF CONTACT AT FOUNDATION

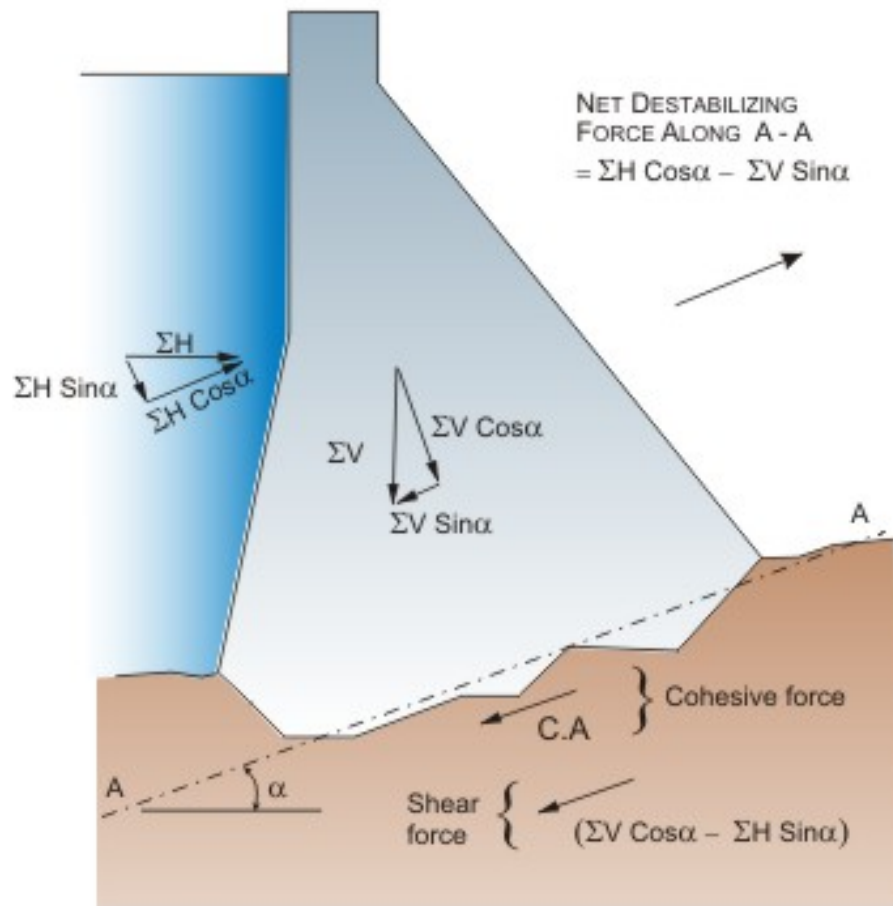

FIGURE. 37: Stability against sliding along concrete dam - rock base interface. Good rock is assumed to exist below

Sliding resistance is also a function of the cohesion inherent in the materials at their contact and the angle of internal friction of the material at the surface of sliding. The junction plane between the dam and rock is rarely smooth. In fact, special efforts are made during construction to keep the interface as rough as possible. There may, however, be some lower plane in the foundation where sliding is resisted by friction alone especially if the rock is markedly stratified and horizontally bedded. Figure 37 shows a typical dam profile with the bed-rock and foundation interface inclined at an

angle  $\alpha$ . Factor of Safety against sliding (F) along a plane may be computed from the following formula:

$$F = \frac{\frac{\text{Net shear force along the plane}}{F_\phi} + \frac{\text{Net cohesive force along the plane}}{F_c}}{\text{Net horizontal destabilizing force along the plane}} \quad (15)$$

Where  $F_\phi$  and  $F_c$  are the Partial Factor of Safety in respect of friction and Partial Factor of Safety of cohesion. IS: 6512-1984 recommends these values to be as given in the following table:

| Loading Condition | $F_\phi$ | $F_c$  |                         |        |
|-------------------|----------|--|-------------------------|--------|
|                   |          | For dams and the contact plane with foundation | For foundation          |        |
|                   |          |  | Thoroughly investigated | Others |
| A,B,C             | 1.5      | 3.6  | 4.0                     | 4.5    |
| D,E               | 1.2      | 2.4  | 2.7                     | 3.0    |
| F,G               | 1.0      | 1.2  | 1.35                    | 1.5    |

The value of cohesion and internal friction may be estimated for the purpose of preliminary designs on the basis of available data on similar or comparable materials. For final designs, however, the value of cohesion and internal friction has to be determined by actual laboratory and field tests, as specified in the Bureau of Indian Standards code IS: 7746-1975 "Code of practice for in-situ shear test on rocks".

In the presence of a horizon with low shear resistance, for example, a thin clay seam or clay infill in a discontinuity (Figure 38), then it would be advisable to include downstream passive wedge resistance P, as a further component of the total resistance to sliding which can be mobilized. In this case, the Factor of Safety along sliding has to be found along plane B-B computing the net shear force and net cohesive force along this plane. The net shear force would now be equal to:

$$(W \cos \alpha + \sum H \sin \alpha) \tan \phi \quad (16)$$

Where W is the weight of the wedge;  $\alpha$  is the assumed angle of sliding failure,  $\sum H$  is the net destabilizing horizontal moment; and  $\phi$  is the internal friction within the rock at plane

B-B. The net cohesive force along plane B-B is determined as equal to  $C.A_{B-B}$ . Here,  $C$  is the cohesion of material and  $A_{B-B}$ , the area, along plane B-B.

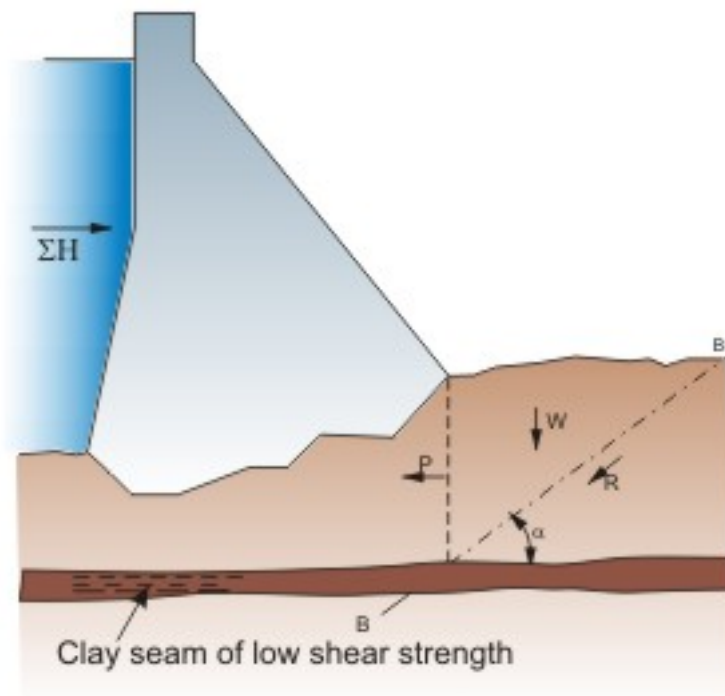

FIGURE.38: Sliding against presence of weak seams resisted by passive wedge resistance

### **Failure against overstressing**

A dam may fail if any of its part is overstressed and hence the stresses in any part of the dam must not exceed the allowable working stress of concrete. In order to ensure the safety of a concrete gravity dam against this sort of failure, the strength of concrete shall be such that it is more than the stresses anticipated in the structure by a safe margin. The maximum compressive stresses occur at heel (mostly during reservoir empty condition) or at toe (at reservoir full condition) and on planes normal to the face of the dam. The strength of concrete and masonry varies with age, the kind of cement and other ingredients and their proportions in the work can be determined only by experiment.

The calculation of the stresses in the body of a gravity dam follows from the basics of elastic theory, which is applied in a two-dimensional vertical plane, and assuming the block of the dam to be a cantilever in the vertical plane attached to the foundation. Although in such an analysis, it is assumed that the vertical stresses on horizontal planes vary uniformly and horizontal shear stresses vary parabolically, they are not

strictly correct. Stress concentrations develop near heel and toe, and modest tensile stresses may develop at heel. The basic stresses that are required to be determined in a gravity dam analysis are discussed below:

### **Normal stresses on horizontal planes**

On any horizontal plane, the vertical normal stress ( $\sigma_z$ ) may be determined as:

$$\sigma_z = \frac{\sum V}{T} \pm \frac{12 \sum V e}{T^3} y \quad (17)$$

Where

$\sum V$  = Resultant vertical load above the plane considered

$T$  = Thickness of the dam block, that is, the length measured from heel to toe

$e$  = Eccentricity of the resultant load

$y$  = Distance from the neutral axis of the plane to the point where ( $\sigma_z$ ) is being determined

At the heel,  $y = -T/2$  and at toe,  $y = +T/2$ . Thus, at these points, the normal stresses are found out as under:

$$\sigma_{z_{heel}} = \frac{\sum V}{T} \left( 1 - \frac{6e}{T} \right) \quad (18)$$

$$\sigma_{z_{toe}} = \frac{\sum V}{T} \left( 1 + \frac{6e}{T} \right) \quad (19)$$

The eccentricity  $e$  may be found out as:

$$e = \frac{\text{Net moment}}{\text{Net vertical force}} \quad (20)$$

Naturally, there would be tension on the upstream face if the overturning moments under the reservoir full condition increase such that  $e$  becomes greater than  $T/6$ . The total vertical stresses at the upstream and downstream faces are obtained by addition of external hydrostatic pressures.

### **Shear stresses on horizontal planes**

Nearly equal and complimentary horizontal stress ( $\tau_{zy}$ ) and shear stresses ( $\tau_{yz}$ ) are developed at any point as a result of the variation in vertical normal stress over a horizontal plane (Figure 39). The following relation can be derived relating the stresses with the distance  $y$  measured from the centroid:

$$\tau_{zy} = \tau_{yz} = \tau_{yzD} - \frac{2}{T} \left[ \frac{3H}{T} + \tau_{yzU} + 2\tau_{yzD} \right] y + \frac{3}{T^2} \left[ \frac{2H}{T} \tau_{yzD} + \tau_{yzU} \right] y^2 \quad (21)$$

Where

$\tau_{yzD} = (\sigma_{zD} - p_D) \tan \phi_D$ , the shear stress at downstream face

$\tau_{yzU} = -(\sigma_{zU} - p_U) \tan \phi_U$ , the shear stress at upstream face

H = the height of the dam

The shear stress is seen to vary parabolically from  $\tau_{yzU}$  at the upstream face up to  $\tau_{yzD}$  at the downstream face.

### Normal stresses on vertical planes

These stresses,  $\sigma_y$  can be determined by consideration of the equilibrium of the horizontal shear forces operating above and below a hypothetical element within the dam (Figure 39). The difference in shear forces is balanced by the normal stresses on vertical planes. Boundary values of  $\sigma_y$  at upstream and downstream faces are given by the following relations:

$$\sigma_{yU} = p_u + (\sigma_{zU} - p_y) \tan^2 \phi_U \quad (22)$$

$$\sigma_{yD} = p_y + (\sigma_{zD} - p_y) \tan^2 \phi_D \quad (23)$$

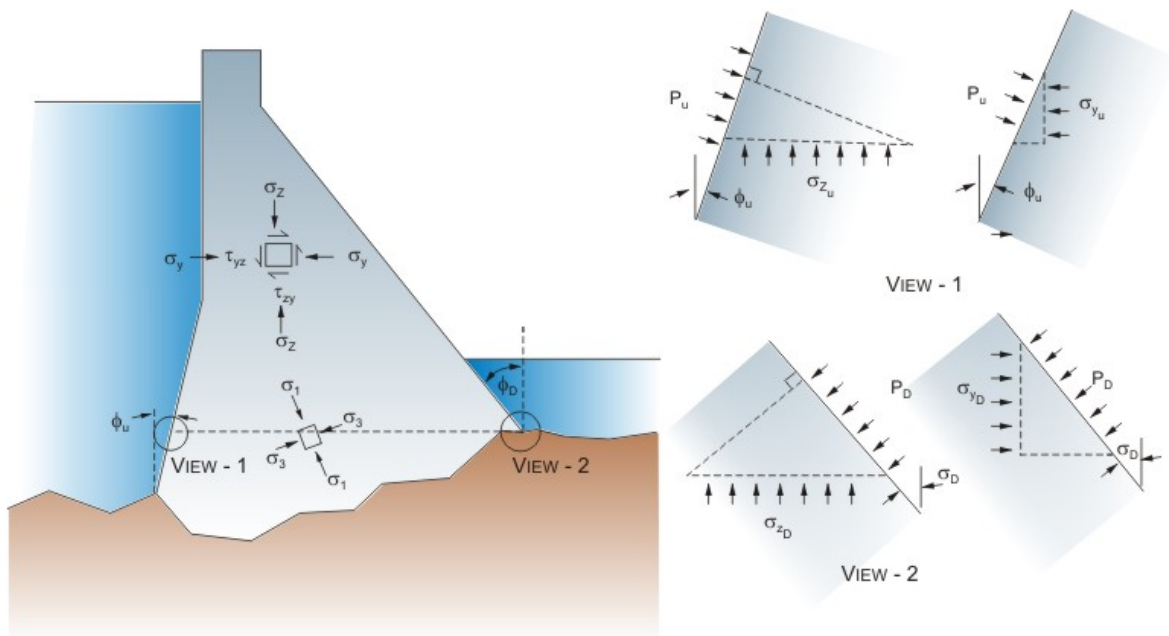

FIGURE.39: State of stress in a concrete gravity dam

### **Principal stresses**

These are the maximum and minimum stresses that may be developed at any point within the dam. Usually, these are denoted as  $\sigma_1$  and  $\sigma_3$  respectively, and are oriented at a certain angle to the reference horizontal or vertical lines. The magnitude of  $\sigma_1$  and  $\sigma_3$  may be determined from the state of stress  $\sigma_z$ ,  $\sigma_y$  and  $\tau_{yz}$  at any point by the following formula:

$$\sigma_{1,3} = \frac{\sigma_z + \sigma_y}{2} \pm \sqrt{\left(\frac{\sigma_z - \sigma_y}{2}\right)^2 + \tau_{zy}^2} \quad (24)$$

The maximum and minimum shear stress is obtained from the following formula:

$$\tau_{\max} = \sqrt{\left(\frac{\sigma_z - \sigma_y}{2}\right)^2 + \tau_{yz}^2} \quad (25)$$

The upstream and downstream faces are each planes of zero shear, and therefore, are planes of principal stresses. The principal stresses at these faces are given by the following expressions:

$$\sigma_{1_u} = \sigma_{z_u} \sec^2 \phi_u - p_u \tan^2 \phi_u \quad (26)$$

$$\sigma_{3_u} = p_u \quad (27)$$

$$\sigma_{1_D} = \sigma_{z_D} \sec^2 \phi_D - p_D \tan^2 \phi_D \quad (28)$$

$$\sigma_{3_D} = p_D \quad (29)$$

### **Permissible stresses in concrete**

According to IS: 6512-1984, the following have to be followed for allowable compressive and tensile stresses in concrete:

Compressive strength of concrete is determined by testing 150mm cubes. The strength of concrete should satisfy early load and construction requirements and at the age of one year, it should be four times the maximum computed stress in the dam or  $14\text{N/mm}^2$ , whichever is more. The allowable working stress in any part of the structure shall also not exceed  $7\text{N/mm}^2$ .

No tensile stress is permitted on the upstream face of the dam for load combination B. Nominal tensile stresses are permitted for other load combinations and their permissible values should not exceed the values given in the following table:

| Load combination | Permissible tensile stress |
|------------------|----------------------------|
| C                | $0.01f_c$                  |
| E                | $0.02f_c$                  |
| F                | $0.02f_c$                  |
| G                | $0.04f_c$                  |

Where  $f_c$  is the cube compressive strength of concrete.

Small values of tension on the downstream face is permitted since it is improbable that a fully constructed dam is kept empty and downstream cracks which are not extensive and for limited depths from the surface may not be detrimental to the safety of the structure.

## 4.6.6 Construction of concrete gravity dam

### *River diversion*

Regardless of the type of dam, whether concrete or embankment types, it is necessary to de-water the site for final geological inspection, for foundation improvement and for the construction of the first stage of the dam. In order to carry out the above works the river has to be diverted temporarily. The magnitude, method and cost of river diversion will depend upon the cross- section of the valley, the bed material in the river, the type of dam, the expected hydrological conditions during the time required to complete the dam construction works, and finally upon the consequences of failure of any part of the temporary works.

For concrete dams, it may be necessary to divert the river during the first phase of the construction of the dam. Once this is complete, the river may be allowed to overtop the dam and flow without causing serious damages to the structure or its foundation. For concrete dams, sluice openings are left open in the first stage of concreting and the higher stages constructed. If the second stage outlets are too small for the flood to pass, they would be submerged after the whole works. At some sites, virtually no risk can be afforded. For the Ukai dam on river, Tapi, which is 4927 m long and maximum height of 68.6 m, no risk of overtopping and possible destruction of the control section could be accepted in view of the very large resident population downstream of the dam. Hence, a diversion channel was excavated to carry 49500 m<sup>3</sup>/s passed through the blocks of the concrete gravity dam section that was intentionally left low.

The Bureau of Indian standards code IS 10084 (part 2) -1994 “Design of diversion works – criteria” describes the design criteria for diversion channel and open cut or conduit in the body of the dam.



At sites where diversion of flow through tunnels or close conduits is not possible (due to topographical considerations) or proves to be uneconomical, diversion through excavated channels called diversion channels is effected. Diversion channels are often classified according to the type of diversion namely, single stage or multiple stage diversion scheme. In the former which is more suitable for narrow valleys, the same set of diversion channel and coffer dams is utilised throughout the period of construction. In the latter, which is generally suitable for wide valleys, the channels and coffer dams are shifted from place to place in accordance with phasing of the work. A more useful classification, however, is based on the type of the dam to be constructed namely diversion channel for masonry or concrete dams and that for the earth or rockfill dams. The following paragraphs taken from Bureau of Indian Standards code IS: 10084 (Part 2) – 1994 “Design of diversion works – criteria” provides criteria for diversion channels for dam construction.

### ***Diversion Channels***

A concrete or masonry dams could be allowed to get overtopped during floods when construction activity is not in progress. The resulting damage is either negligible or could be tolerated without much concern. Therefore, it is customary to adopt diversion flood which is just adequate to be handled during non monsoon season, when construction activity of the dam is continued. Generally the largest observed non-monsoon flood or non-monsoon flood of 100 year return period is adopted as a diversion flood. This is generally a small fraction of the design flood of the spillway and, therefore, diversion channel required to handle this flood is obviously small. Advantage is also taken of passing the floods over partly completed dam or spillway blocks, thereby keeping the diversion channel of relatively smaller size. In such a case a small excavated channel either in the available width of the river or one of the banks of the river proves to be adequate. Construction sluices are located in such excavated channels which allow passage of non-monsoon flows without hindrance to the construction activity. Such sluices are subsequently plugged when the dam has been raised to adequate height. If the pondage is not allowed even when the dam has been raised to sufficient height, the river outlets are often provided in the body of the non overflow or overflow dam to pass the non monsoon flows which later on are kept for permanent use after completion of construction. If the diversion channel is excavated on one of the river banks, it is possible to use the same for locating an irrigation outlet, a power house or a spillway depending upon the magnitude and purpose of the project. Figures 40 and 41 show typical layouts of diversion channel for masonry/concrete dams in wide and narrow rivers respectively.

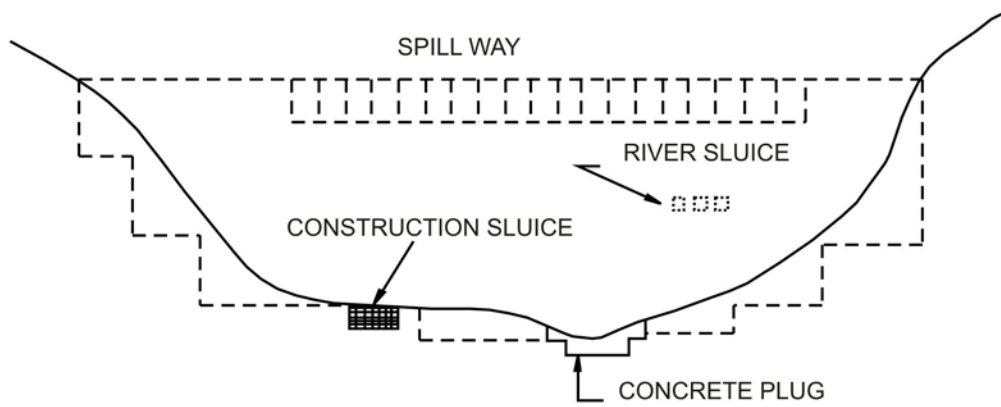
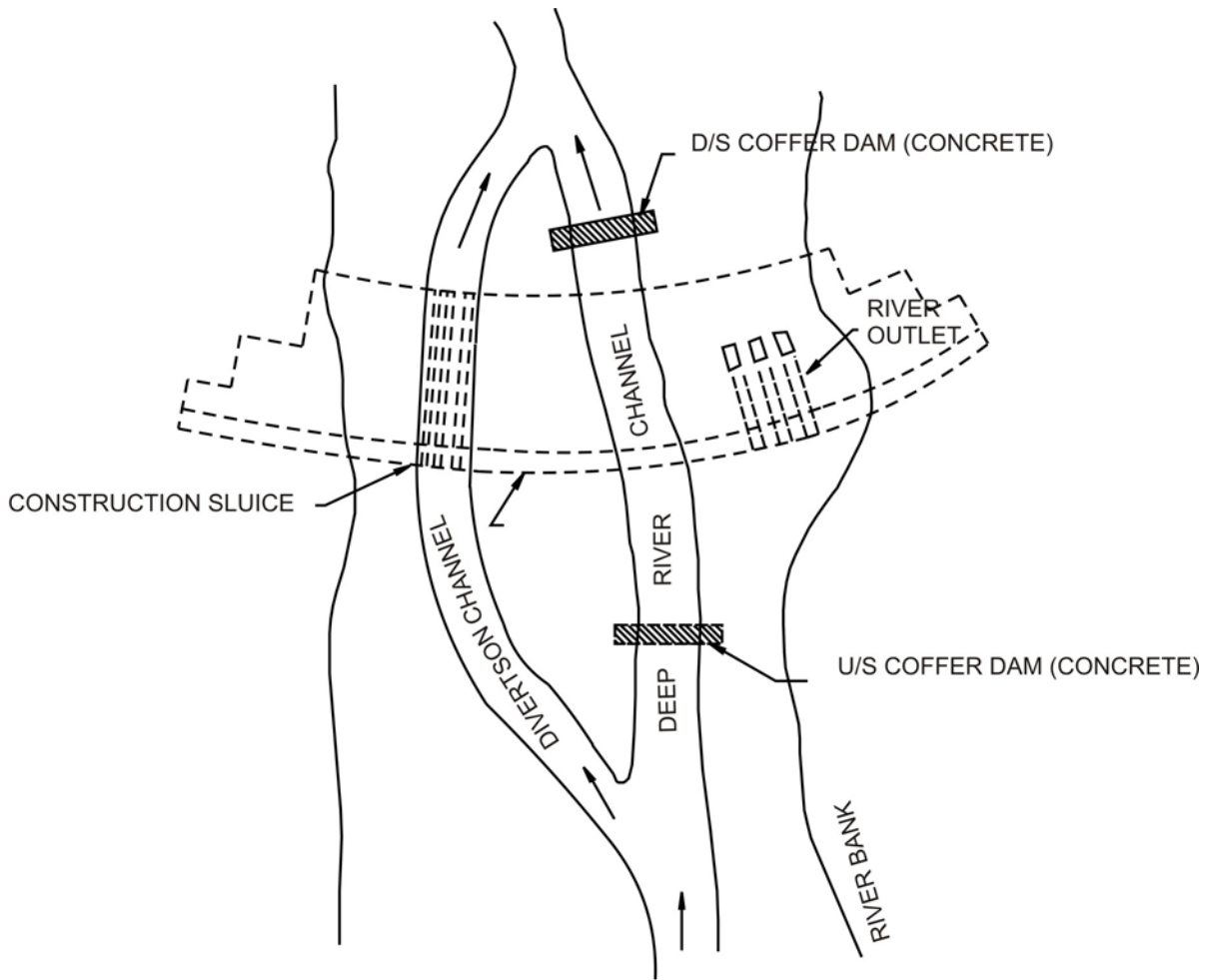

FIGURE 40. DIVERSION CHANNEL FOR CONCRETE DAM IN A WIDE RIVER

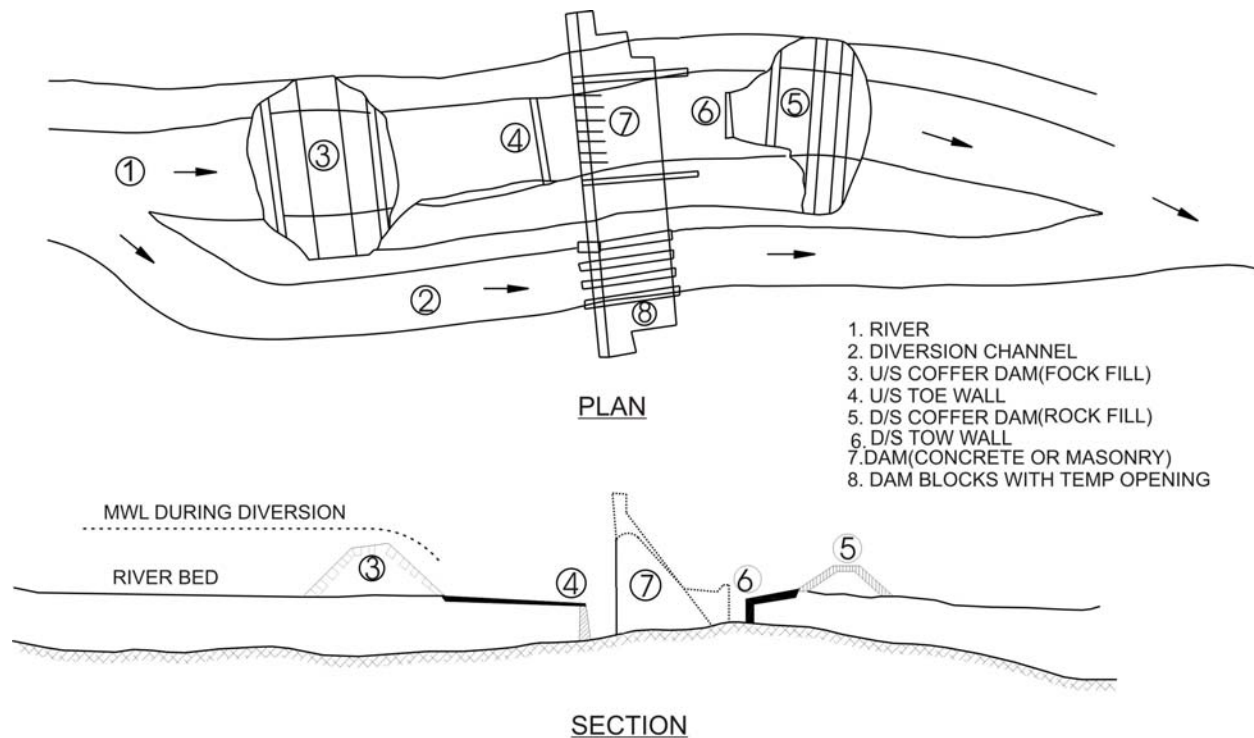

FIGURE 41. DIVERSION CHANNEL FOR CONCRETE DAM IN A NARROW RIVER

#### 4.6.7 Preparation of foundation for dam construction

A concrete gravity dam intended to be constructed across a river valley would usually be laid on the hard rock foundation below the normal river overburden which consists of sand, loose rocks and boulders. However at any foundation level the hard rock foundation, again, may not always be completely satisfactory all along the proposed foundation and abutment area, since locally there may be cracks and joints, some of these (called seams) being filled with poor quality crushed rock. Hence before the concreting takes place the entire foundation area is checked and in most cases strengthened artificially such that it is able to sustain the loads that would be imposed by the dam and the reservoir water, and the effect of water seeping into the foundations under pressure from the reservoir.

Generally the quality of foundations for a gravity dam will improve with depth of excavation. Frequently the course of the river has been determined by geological faults or weaknesses. In a foundation of igneous rock, any fault or seam should be cleaned out and backfilled with concrete. A plug of concrete of depth twice the width of the seam would usually be adequate for structural support of the dam, so that depth of excavation will, on most occasions depend upon the nature of infilling material, the shape of the excavated zone and the depth of cutoff necessary to ensure an acceptable hydraulic gradient after the reservoir is filled. An example of this type of treatment for Bhakra dam is shown in Figure 42.

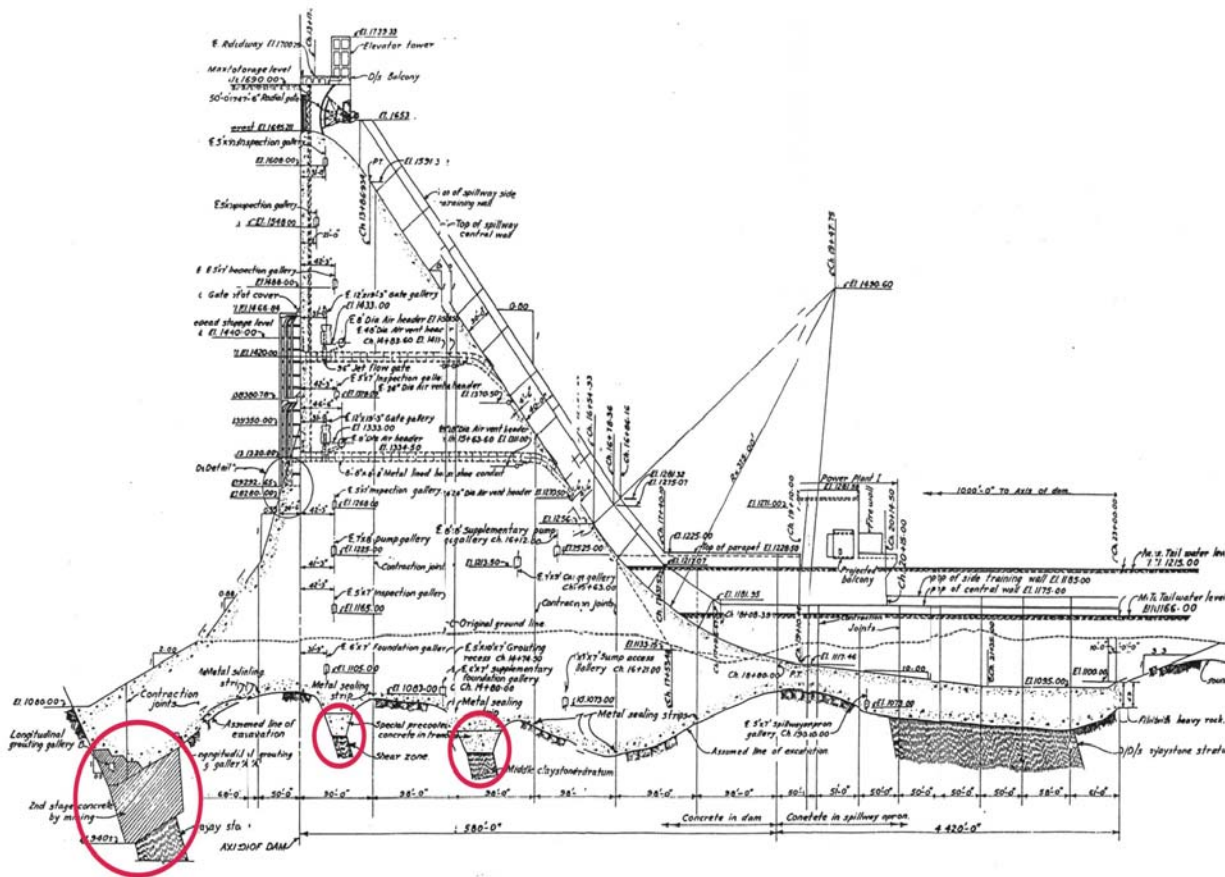

FIGURE 42. FOUNDATION FEATURE FOR BHAKRA DAM

Improvement of the foundation for a dam may be effected by the following major ways:

1. Excavation of seams of decayed or weak rock by tunneling and backfilling with concrete.
2. Excavation of weak rock zones by mining methods from shafts sunk to the zone and backfilling the entire excavated region with concrete.
3. Excavation for and making a subterranean concrete cutoff walls across leakage channels in the dam foundation where the where the water channels are too large or too wet for mining or grouting
4. Grouting the foundation to increase its strength and to render it impervious.

Grouting of the foundation of the dam to consolidate the entire foundation rock and consequently increasing its bearing strength is done by a method that is referred to as consolidation grouting. This is a low pressure grouting for which shallow holes are drilled through the foundation rock in a grid pattern. These holes are drilled to a depth ranging from 3 to 6 m. Prior to the commencement of the grouting operation, the holes are thoroughly washed with alternate use of water and compressed air to remove all

loose material and drill cuttings. The grout hole are then tested with water under pressure to obtain an idea of the tightness of the hole which is necessary to decide the consistency of the grout to be used and to locate the seams or other openings in the rock which are to be plugged . The grout is then injected with these holes at relatively low pressure which is usually less than about 390 KN/m<sup>2</sup>. Since this is a low pressure grouting it is accomplished before any concrete for the dam is laid. This grouting results in the consolidation of the foundation into more or less monolithic rock by bonding together the jointed or shattered rocks. Some of the recommendations for grouting under pressure in rock foundations have been taken from Bureau of Indian Standards code IS: 6066 – 1994 “Pressure grouting of rock foundations in river valley projects – recommendations” have been presented in the following paragraphs.

### ***Methods of rock grouting***

Rock grouting consists essentially of drilling a series of grout holes in rock and injecting grout under pressure, which eventually sets in the openings and voids in the rock. The drilling and grouting operations can be carried out either to the full depth in one operation or in successive depths either by stage grouting or packet grouting. Grouting in the valley should proceed from river bed to the abutments. There are two broad methods for grouting: Full depth grouting and stage grouting.

In the full depth method each hole is drilled to the full desired depth, washed, pressure tested and grouted in one operation. This method is usually limited to short holes 5m or less in depth or holes up to 10 m that have only small cracks and joints with no risk of surface leakage. In deep bore holes high grouting pressures have to be used for proper penetration of grout at an economical spacing of holes. As full depth grouting involves the risk of disturbance in the upper elevation it is not generally considered for grouting deep holes. For grouting in heterogeneous strata, where the nature of rock discontinuities is subject to large variations in relation to the depth, full depth grouting is not recommended and stage grouting is preferred to packer grouting in such cases.

Stage grouting is done by drilling the holes to a predetermined depth and grouting this initial depth at an appropriate pressure to its final set (within 2 to 4 hours) deepened for the next stage. Alternatively the grout is allowed to harden and re drilling is carried out through the hardened grout and the hole extension to the next stage. In another procedure called the one stage re drilled method, which is sometimes used grout is washed out within a small depth of the top of the stage being grouted and only one stage is re drilled for proceeding to the next stage. In each of procedures the cycle of grouting-drilling-washing-re drilling is repeated until the required depth of the hole is reached.

### ***General criteria for size and depth of grout holes***

The pattern and depth of holes is governed primarily by the design requirements and the nature of the rock. When the purpose is consolidation, the holes are arranged in a regular pattern over the entire surface area required to be strengthened and the depth is determined by the extent of broken rock as well as the structural requirements regarding the deformability and strength of the foundation. When the purpose is impermeabilisation the grout holes are arranged in a series of lines to form a curtain

approximately perpendicular to the direction of the seepage. The depth of holes is dependent on design consideration as also on the depth of pervious rock and configuration of zones of relatively impervious strata.

The size of grout holes is generally less important than the cost of drilling holes and the control of the inclination. For grouting with cement, 38 mm holes are used. The advantage gained by drilling large holes does not often justify the increase in drilling costs. In long holes the diameter at the top of the hole may have to be larger than the final diameter at the bottom of the hole to facilitate telescoping or allow for the wear of the bit.

### ***Patterns of holes for curtain grouting***

Single lines grout curtains are effective only in rocks having a fairly regular network of discontinuities with reasonably uniform size of openings. In such cases a curtain of adequate width can be achieved by grouting a single line of holes. In massive rocks, with fine fissures uplift control is primarily obtained by drainage and the grout curtain is only used as a supplementary measure to avoid concentration of seepage which may exceed the capacity of the drainage system. Single line curtain may serve this limited objective in comparatively tight rock formations.

In single line curtains (Figure 43), it is customary to drill a widely spaced system of primary holes, subsequently followed by secondary and tertiary holes at a progressively small spacing. The usual practice is to split the spacing from primary to the secondary to the tertiary phase. One of the criteria for deciding on the primary spacing is the length of expected intercommunication of grout between holes. The initial spacing usually varies from 6m to 12 m but the choice of spacing should be based on geological conditions and on experience. At every phase of the grouting operation, the results of percolation tests and ground absorption data should be compared with the previous set of holes in order to decide whether a further splitting of the spacing of holes is worthwhile. When no significant improvement is noticed either in terms of decrease of the grout absorption or water percolation, careful review should be made of rock features, the nature of the rock and its relation to the pattern of holes. Sometimes it may be more advantageous to drill another line of holes at a different angle and orientation than to split the spacing further. Spacing below 1 meter are rarely necessary and the requirement of a spacing closer than 1 meter often indicates an unsuitable orientation and inclination of holes. Possibly multiple line curtains may be necessary. If the area is too limited, the setting time of the grout becomes important since it is not desirable to drill close to a freshly grouted hole. Before pressure grouting is started, drilling of all the holes should be completed within a distance of 20 m of the hole to be grouted.

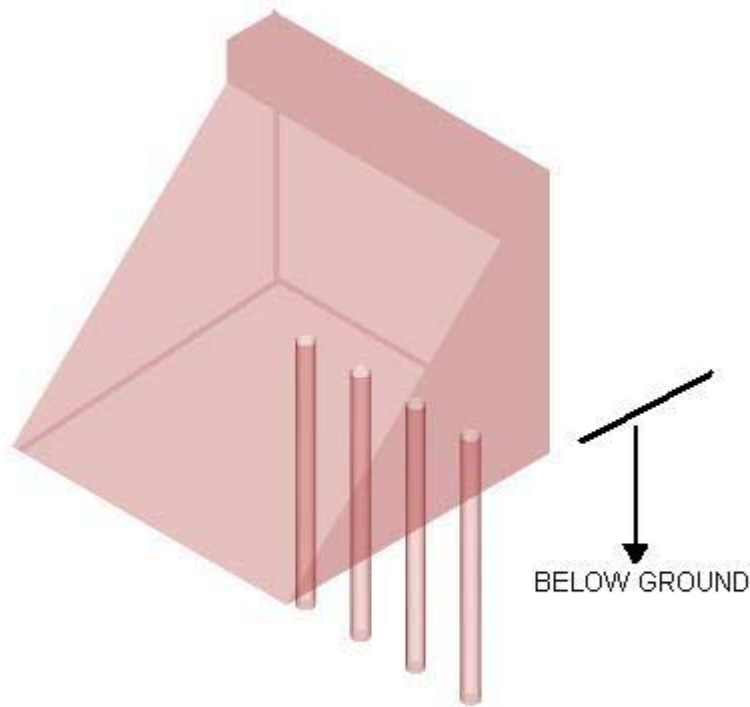

**FIGURE 43. Single line of grout holes  
below a concrete gravity dam**

Depending upon initial investigation and strata conditions, the spacing of primary hole treatment should be decided. If the primary holes were spaced more than 6 m apart secondary holes should be drilled and grouted. On completion of primary holes spaced closer than 6m or secondary holes (when the primary holes are spaced more than 6 m), should the percolation tests carried out in a few test holes indicate that further grouting of the area is necessary, secondary, or tertiary treatment as the case may be, should be carried out systematically thereafter in the whole area or in the particular section where the rock conditions are bad. Similarly tertiary holes should be taken over the whole area or the full length of the section which requires the treatment.

In addition to the systematic grouting of primary Secondary or tertiary and subsequent holes it may be necessary to drill and grout additional holes for treatment of peculiar geological feature such as faults, sheared zones and weathered rock seams.

### ***Pattern of holes for consolidation grouting***

The choice of pattern of holes, for consolidation grouting depends on whether it is necessary to wash and jet the hole systematically. When washing has to be carried out a hexagonal pattern (Figure 44) would be preferred as this admits for flow reversal. When systematic washing and jetting is carried out to remove all soft material in seams it is generally not necessary to use a primary and secondary system of holes.

When it is desirable to test the efficacy of consolidation grouting by comparing the grout absorption in primary and secondary holes a rectangular or square pattern (Figure 44) of holes would be preferred. This is generally the case when the joints are irregular and relatively free from in-filling or it is not necessary to remove the material filling the joints.

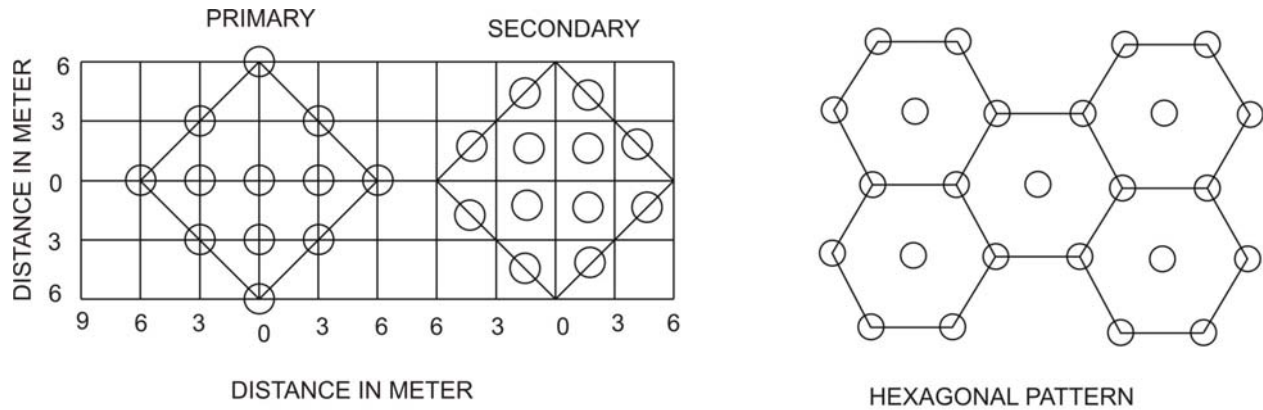

FIGURE 44. TYPICAL PATTERNS FOR CONSOLIDATION GROUTING

### **Grouting mixture**

Rock grouting is normally performed with a mixture of cement and water with or without additives. The cement should be ordinary Portland, Portland Pozzolana, Portland slag, Supersulphated or Sulphate-resisting Portland. The solid materials which may be used as additive to the grout mixture could be Paxxolanas (such as fly ash and calcined shade), fine sand or other fine non-cementitious materials like clay and silt. While using additives constant field checks and review should be undertaken to achieve the desired results in respect to permeability and strength. Admixtures when added in small quantities to the grout mixture impact certain desirable characteristics like delaying or hastening setting time and increasing the workability.

### **Drilling equipment**

The entire grouting operation is carried out by first drilling and then injecting the grout under pressure. The various types of drilling equipments can be grouped as under

- A. Precursive Drilling equipment
  - a) Standard drifter or wagon drill
  - b) Dom the hole drilling equipment, and
  - c) Overburden drilling equipment
  
- B. Rotary drilling equipment with suitable drive, that is hydraulic, electric, diesel or compressed air



Percussive drilling methods are generally more economical in all kind of rocks. For deep rocks it may be advantageous to use overburden drilling equipment. By virtue of the greater rigidity of the casing tube combined with the drill rods, better control on inclination of holes can generally be achieved in the overburden drilling equipment. Down the hole hammer is also capable of maintaining a better control on the inclination. However, the hammer may get clogged when the drill cuttings form slush in form saturated strata and cannot be removed by air flushing.

During percussive drilling in stratified rocks where the resistance of the rock is prone to variation the holes may get curved and control on inclination may be lost. In such cases guide tubes may be used for ensuring verticality of the holes or alternatively rotary drilling may be used. Irrespective of whether air or water is used for flushing the hole during drilling, thorough cleaning by water flushing is essential before starting grouting operations.

### **Grouting equipment**

The major equipment required for carrying out grouting are Grout Mixer and Grout Pump. These are explained below.

**Grout mixer:** The mixer should have two tank namely mixing tank and agitating tank. Mixers are generally cylindrical in shape, with axis either horizontal or vertical or equipped with a system of power driven paddles for mixing. Grout should be mixed in a mixer operating at 1500 r.p.m. or more. The high speed of mixing serves the purpose of violently separating each cement grain from its neighbour thus permitting thorough wetting of every grain. This proves to be advantageous by chemically activating each grain to through hydration before reaching its final resting state. Further individual grains penetrate finer cracks more readily than flocs. Vertical barrel type mixers have proved satisfactory when small mixers are required for use in confined or limiting working spaces. This type of mixer consists essentially of a vertical barrel having a shaft with blades for mixing, driven by a motor mounted on top of the mixer above the barrel. Centrifugal pump mixers mix the grout by re circulating it through a high speed centrifugal pump. They are sometimes referred to as colloidal type mixers, but they don't achieve a true colloidal grout mix. However they possess considerable merit and produce grout of excellent texture. When mixing sand-cement grouts their action tends to guard against segregation.

**Grout pump:** A pump suitable for grouting should permit close control of pressures, allow a flexible rate of injection, and be designed to minimize clotting of valves and ports. Grout pumps are of three types namely, piston, screw, and centrifugal.

### **Washing and testing of holes and surface preparation**

Any grouting operation requires major washing of the holes, testing of the holes with water under pressure and surface preparation. The purpose of washing the holes is two fold. First to clean the hole to remove the material deposited on the surface during the drilling operation and second to provoke deliberate inter-connections between adjoining grout holes to remove known seams and layers of erodable material. It should be borne

in mind that inter-connections between holes are effective only if the washing operations are carried out systematically to remove all the soft material. Isolated inter-connections don't serve much useful purpose as soft material may still remain in position in a known and irregular pattern. A distinction is therefore made between washing of holes at the end of the drilling operation and systematically washing of group of holes in order to remove the erodable material in the intervening area for which the term jetting is used.

### **Washing of holes**

On completion of a drilling of a stage and before injection, the holes should be washed by allowing drilling water to run until the return from the hole is reasonably clean. The quantity of water flowing into the hole during the period should be adequate and generally not less than 15 l/min.

When no return of drilling or washing water occurs, the holes should be washed for a reasonable period based on site experience. This is generally for 20 minutes. If an abrupt loss of drill water occurs during drilling and similarly when a strong flow of artesian water is encountered, the drilling should be stopped and the hole grouted even if it has not reached its final depth.

### **Percolation tests**

For routine grouting operations, and simple water test conducted before and after grouting, the test pressure should be limited so as to avoid hydraulic fracture. The value of limiting pressure for various strata and depths should be established by preliminary investigations where cyclic tests should be conducted to evaluate pressure at which fracturing occurs. Additional tests may be carried out in trial grouting plots or in selected primary grouting holes to verify the pressure limits established during preliminary investigations.

Water percolation tests may be used to measure the effectiveness of the grouting treatment. The tests may be simple or cyclic. Cyclic testing is recommended for evaluation stage while before and during grouting operations simple tests should be carried out.

Water tests should be carried out in primary stages before injection to amplify information available from the site investigation. Tests should be carried out in secondary stages before injection to indicate the results of primary injections. Test may be carried out in individual test holes at any time to indicate the results of all treatment carried out before that time. Test holes drilled for this purpose should be sited midway between completed injection holes.

### **Jetting**

Jetting operation are carried out in order to deliberately provoke connection between bore holes and to remove known deposits of erodable material. Jetting should be carried out in group of holes arranged in a square, triangular or hexagonal pattern known as cells.

### **Surface treatment**

For effective treatment of the surface zones, sufficient pressure should be developed to achieve the spread required with a convenient spacing of holes. Adequate cover should be maintained during grouting to ensure that adequate pressure is applied without causing upheaval or excessive surface leakage.

### **Injection of grout**

As for the method of injection, grout holes should be injected by direct connection to the pump. Each pump should be provided with a packer at the surface or with a short strand pipe threaded at its outer end to accept stand or control fittings, which should be provided with a pressure gauge, bleeder valve and a valve enabling delivery from pump to be cut-off from the hole. Either single line or circulation system may be used, usually circulating system is preferred, however when adequate controls are possible to regulate the pump discharge and pressure by using pumps of suitable design, single line grouting system can be used.

Once the grouting of stage or group of holes has been commenced it should be continued without interruption up to completion. In general a stage may be considered complete when the absorption of grout at the desired limiting pressure is less than 2 l/min averaged over a period of 10 minutes.

As far as practical a continuous flow of grout should be maintained at the desired pressure and the grouting equipment should be operated to ensure continuous and efficient performance throughout the grouting operation. After grouting is completed, the grout holes should be closed by the means of a valve to maintain to grout pressure for a sufficient period to prevent escape of the grout due to back pressure and flow reversal, due to causes like artesian conditions. For this purpose a period of one or two hours is generally sufficient, however this should be verified by trial.

### **Pressure**

The grouting pressure should be adequate to achieve the desired grout and the pressure should be limited so as to avoid disturbances and upheaval of the ground and should take into account reservoir pressure.

For structures on rock foundations, it is a basic requirement that no disturbance should be caused to the surface zones of the foundation by the grouting operation. When grouting is undertaken below an existing structure no upheaval of the foundation can be allowed as it would have very harmful consequences on the structure and/or the equipment. In general the disturbance caused by the grouting is dependent more on the manner in which the pressure is developed and the nature of the rock than on the absolute magnitude of pressure. Relative higher pressures can be sustained without damage to the foundations, when pressure is built up gradually, as resistance to flow is developed by deposition of grout. On the other hand when pressures are raised hastily damage can occur even at relatively low pressure. In general, horizontal stratified or low dipping rocks are more vulnerable to disturbance by grouting pressure than fractured igneous or metamorphic rocks or steeply dipped sedimentary rocks. Rocks previously

subjected to folding or fracturing or rocks in the process of adjustment after removal of overburden load are also more vulnerable to disturbances.

The most common difficulty experienced in consolidation grouting is surface leakage. It is therefore customary to pipe through the entire height of concrete or masonry and carry out the grouting after the rock has been completely covered. This not only eliminates surface leakage but permits use of higher pressure so that even the smaller seams can be grouted effectively.

#### 4.6.8 Temperature control of mass concrete for dams

When a concrete gravity dam is constructed of mass concrete, it undergoes volumetric changes with time due to the release of heat of hydration by the concrete. A rapid rise in the temperature of mass concrete takes place during the phase when the concrete mass is in plastic stage and undergoes hardening. After hardening, the concrete gradually cools due to effect of atmospheric temperature, which tends to subject the concrete to high tensile stresses. Cracking occurs in the concrete when these tensile stresses exceed the tensile strength of the concrete. This cracking is undesirable as it affects the water tightness, durability and appearance of hydraulic structures. Hence, methods to control the temperature rise during dam construction is absolutely essential. The methods to control temperature in dams is prescribed in the Bureau of Indian Standard code IS: 14591-1999 "Temperature control of mass concrete for dams – guidelines", some of which are given below.

Most commonly used methods are precooling, post cooling and reducing heat of hydration by proper mix design. The ideal condition would be simply to place the concrete at stable temperature of dam and heat of hydration removed, as it is generated, so that temperature of concrete is not allowed to rise above stable temperature. However this is not possible to achieve practically. Therefore, the most practical method is to pre cool concrete so as to restrain the net temperature rise to acceptable levels.

##### **Pre-cooling**

One of the most effective and positive temperature control measure is precooling which reduces the placement temperature of concrete. The method, or combination of methods, used to reduce concrete placement temperatures will vary with the degree of cooling required and the equipment available with the project authority or the contractor. In this method usually the fine and coarse aggregates and the water are separately cooled to the requisite temperatures.

Mixing water may be cooled to varying degrees, usually from 0<sup>0</sup> C to 4<sup>0</sup> C. Adding crushed ice or ice flakes to the mix is an effective method of cooling because it takes advantage of the latent heat of fusion of ice. The addition of large amount of ice flakes, however, may not be possible in cases where both coarse aggregate and sand contain appreciable amount of free water, in which case the amount of water to be added to the mix may be so small that substitution of part of the water to be added with ice may not

be feasible. From practical considerations, not more than 70 percent of water should be replaced by crushed ice. Although most rock minerals have comparatively low heat capacity, since aggregates comprise the greatest proportion of concrete mix, the temperature of the aggregate has the greatest influence on the temperature of the concrete. Cooling of coarse aggregate to about 1.7°C may be accomplished in several ways. One method is to chill the aggregates in large tanks of refrigerated water for a given period of time or by spraying cold water. Effective cooling of coarse aggregate is also attained by forcing refrigerated air through the aggregate while the aggregate is draining in stock piles, or while it is in a conveyer belt or while it is passing through the bins of the batching plant.

### **Post-cooling**

Post cooling is a means of crack control. Control of concrete temperature may be effectively accomplished by circulating cold water through thin walled pipes embedded in concrete. This will reduce the temperature of newly placed concrete by several degrees, but the primary purpose of the system is to accelerate the subsequent heat removal and accompanying volume decrease, during early ages when the elastic modulus is relatively low. Post cooling is also used where longitudinal contraction joints are provided in order to reduce the temperature of concrete to the desired value prior to grouting of transverse contraction joint. Post cooling will create a flatter temperature gradient between the warm concrete and the cooler exterior atmosphere which, in turn, helps in avoiding temperature cracks. Other methods such as evaporative cooling with a fine water spray, cold water curing and shading may prove beneficial, but the results are variable and do not significantly affect the temperature in the interior of massive placement. The embedded cooling system consist of aluminum or synthetic plastic pipe or tubing generally of 25 mm diameter and 1.50 mm wall thickness placed in grid like coils over the top of each concrete lift. When the expected active cooling period exceeds 3 months, steel tubing should be used. The number of coils in a block depends upon the size of the block and the horizontal spacing of the pipes. For practical reasons, pipe coils are placed and tied to the top of a hardened concrete surface and thus vertical spacing of the pipe corresponds to lift thickness. A horizontal spacing same as the vertical spacing will result in the most uniform cooling pattern but variations may be allowed. Supply and return headers, with manifolds to permit individual connections to each coil are normally placed on the downstream face of the dam. In some case, cooling shafts, galleries and embedded header system may be used to advantage.

### **4.6.9 Concreting procedures for gravity dams**

A concrete gravity dam is normally executed as a mass concrete work, except for some reinforced concreting works as in:

- Piers and bridges over the spillway
- Around galleries and other openings
- Divide wall between adjacent spillways
- Energy dissipators

- Intake to sluices
- Power house if built as a part of the dam

The Bureau of Indian Standards code IS 457-1957 “Code of practice for general construction of plain and reinforced concrete for dams and other massive structures” provides guidelines for practices to be followed in plain and reinforced concreting for mass concrete dams. The main points that have to be taken care are mentioned in the following paragraphs

### **Aggregate production**

Huge quantities of aggregate would be required for the construction of a massive structure like a concrete gravity dam. The acceptability of the natural aggregate is to be judged upon the physical and the chemical properties of the material and the accessibility, proximity to site and economic workability of the deposit. A suitable quarry has to be identified in the neighbourhood that can supply continuous source of aggregates.

### **Structural steel**

These may be according to the latest recommendations of the relevant bureau of Indian Standard Codes.

### **Concrete production and handling**

Standard practice is for materials to be batched by weight. The time of mixing is often specified as 2 minutes. The procedure to be adopted for moving concrete from the mixers on to the dam will be governed by site conditions. Having produced a good plaeable concrete, the problem is to transport it to the dam site with the least possible segregation or change in consistency, so that it may be compacted uniformly into the dam without reasonable effort. Nowadays a cableway laid across the dam valley is often used with buckets of capacity 1.5 to 2 m<sup>3</sup>. At many construction sites concrete is placed using chutes or even a belt conveyor. It is recommended that concrete shall have to be placed in position within 30 minutes of its removal from the mixer.

### **Concrete placing, consolidation and curing**

For laying concrete over the rock foundations, it has to be ensured that the surface is clean and free from mud, dirt, oil, organic deposits, or other foreign material which may prevent a tight bond between rock and concrete. In case of earth or shale foundations all soft or loose mud and surface debris shall have to be scrapped and removed. Then the surface has to be moistened to a depth of about 15 cm to prevent the subgrade from absorbing water from the fresh concrete. A layer of concrete that is laid is generally kept as 1.5 m, in a view to ease construction and limit excessive temperature rise. These layers of concreting are called lifts and between two successive lifts a horizontal joint would invariably arise. The concrete of subsequent lifts has to be placed after allowing sufficient time for the previously laid concrete to cool and attain its initial set and become hard. Prior to placement of concrete of the next lift, the surface of the

previously placed concrete has to be thoroughly cleaned by the use of high velocity jet of water and air as well as by wet-sand blasting. Further immediately before the concrete placing of the next lift begins, a 12.5 mm thick layer of mortar should be applied to permit proper bond between the concrete of the lower lift. Since the area of the concrete block near the foundation would be quite large, joints in the vertical plane, but parallel to the dam axis have to be introduced to ease the concrete placement and to allow safe dissipation of the heat of hydration of concrete. These joints called the longitudinal joints are normally spaced at intervals of 15m to 30 m. Thus during construction a continuous concrete pour is seen to be confined between the transverse joints (defining a block) and the longitudinal joints. Once a lift is cast it is thoroughly compacted with needle vibrators. The longitudinal joints subdivide each block formed by the transverse joints into several smaller sub blocks, but since each block must be a monolithic, these joints are invariably provided with horizontal keys (or undulations) over the entire surface, which helps to make a good bond with the adjacent lift. It has however, been recognized that the provision of longitudinal joints is basically unsound unless a high degree of perfection is maintained while placing the adjacent pore of concrete and then grouting the gap properly. Hence the present practice is to avoid the longitudinal joints altogether, even in the case of high dams and a better alternative is to attain necessary temperature control by the methods described earlier. Curing of concrete is important but a difficult task for the construction engineer. Primarily it is necessary to maintain satisfactory moisture content in the hardening concrete. This may be achieved either by the application of water (usually from sprinklers or perforated hoses, or occasionally by ponding on the top of the lift) or by prevention of loss of water (by application of some membrane to the surface). A second requirement for good curing is favourable temperature. This can be achieved by any of the water methods but not by the membrane methods.

#### **4.6.10 Instrumentation in concrete gravity dams**

Normally, instruments are installed in a concrete gravity dam to measure the various parameters that indicate the structural health of the dam and the state of the foundation. These instruments have been classified into two types: obligatory and optional, by the Bureau of Indian Standards code IS 7436(part2)-1997 “Guide for types of measurements for structure in river valley projects and criteria for choice and location of measuring instruments”. These two types of instruments are explained in the following paragraphs.

##### ***Obligatory Measurements***

The following measurements are obligatory for all dams:

- a) Uplift pressure at the base of the dam at a sufficient number of transverse sections
- b) Seepage into the dam and appearing downstream there-from;
- c) Temperature of the interior of the dam; and

d) Displacement measurements - Except for very small structures (of height 20 m and below not involving any foundation complications). Displacement measurements should include one or more of the following types of -measurements:

- 1) Those determined by suspended plumb lines;
- 2) Those determined by geodetic measurements where warranted by the importance of the structure;
- 3) Those determined by embedded resistance jointmeters at contraction joints where grouting is required to be done.

### ***Optional Measurements***

The following measurements are optional and may be undertaken where warranted by special circumstances of project. These would be beneficial for high dams, for structures of unusual design, for structures where unusual or doubtful foundations exist, for the verification of design criteria and for effecting improvement in future designs:

- a) Stress
- b) Strain
- c) Pore pressure (as distinct from uplift pressure), and
- d) Seismicity of the area and dynamic characteristic of the structure.

Due to ever increasing demand of power, emphasis has been laid to construct large size of hydro electric project with very high dam. With the present trend, dam sites are neither geologically seismically suitable as most of the best sites have already been considered for the purpose. Due to this reason those measurements that were considered optional at the time of framing this code may become obligatory now for high dams specially in the Himalayan region.

The various types of parameters that are measured, whether obligatory or optional, are described in the following paragraphs.

### ***Measurement of Uplift Pressure***

It is important to determine the magnitude of any hydraulic pressure at the base of a dam. The effect of uplift on a dam is to reduce its effective weight on account of resulting buoyancy.

### ***Measurement of Seepage***

Seepage is, undoubtedly, the best indicator of the overall performance of a dam because this reflects the performance of entire dam and not just the condition at discrete instrumented points. Any sudden change in the quantity of seepage without apparent cause, such as a corresponding change in the reservoir level or a heavy rainfall, could indicate a seepage problem. Similarly, when the seepage water becomes cloudy or discoloured, contains increased quantities of sediment, or changes radically in chemical content, a likely serious seepage problem is indicated.

It is customary to provide grout curtain near the upstream face of the dam. Besides, a drainage curtain in the foundation and porous drain in the body of the dam are provided



to intercept any seepage that passes through the grout curtain and through the body of the dam respectively. Measurement of seepage water along with uplift measurement at the plane of contact of the dam and its foundation will give direct indication of the effectiveness of the grout curtain and drainage curtain and will indicate whether any remedial measures are necessary. The chemical analysis of the seepage water through the foundation drainage system will help in assessing whether any foundation material is being washed out.

Likewise the quantum of water passing through ungrouted contraction joints or cracks would indicate about the workmanship in general as also any damage that might have been caused to the seals in the contraction joints. The chemical analysis of the water in the case of masonry dam may be indicative of any possible leaching action on the mortar used in the construction of the masonry dam. Corrective measures such as grouting of dam and foundation, besides improving existing drainage or providing additional drainage could thus be planned.

Wet spots or seepage appearing at new or unplanned locations at the abutments or downstream of a dam could also indicate a seepage problem. Measurement of seepage downstream of the grout curtain provides a direct indication of the adequacy and effectiveness of the grout curtain, drainage curtain and functioning of the drains and holes to decide when and where remedial measures may be required.

### ***Measurement of Temperature during Construction***

For concrete gravity dams it is very important to know the thermic variations in the dam during its construction which enables to determine whether the concrete setting process is normal or otherwise. To achieve this purpose, temperature measuring devices are embedded within the dam body and also mounted on the surface according to a predetermined plan for useful observations. Any abnormal setting process indicated by temperature observations may lead to a change in the concrete lift height, and also changes in the treatment of aggregates before concreting and of the mass concrete during curing.

### ***Measurement of Temperature of the Dam interior***

It is necessary to measure temperature in the body of concrete and masonry dams in order to ascertain the nature and extent of thermal stresses and the consequent structural behaviour of the dam and also to ascertain when to undertake grouting of contraction joints that may have been provided for the structure.

### ***Measurement of Temperature of Reservoir Water and Air***

Measurement of temperature of reservoir water and air is essential for distinguishing the effects of ambient and water temperatures on such measurements as deflection, stresses, strains, joint movements and settlements.

### ***Measurement of Displacement***

Measurement of displacement of points either between two monoliths, or between foundation and body of the dam or the displacement of any joint of the dam with respect

to the surrounding area will immediately reveal any distress conditions developing in the dam. Measurement of displacement is thus one of the most important factors to be studied while observing the structural behaviour of a dam.

### ***Internal Joint Movement***

Concrete and masonry dams are generally built in blocks separated by transverse joints. It is essential to know whether there is any relative movement between two blocks. The movement is likely to be due to differential foundation behaviour. Further, the relative movement of blocks is important from the point of view of growing of transverse contraction joints.

### ***Surface Joint Movement***

Measurement of joint movement at the surface of the locations accessible from galleries is made by detachable gauges with a view to assess the amount of joint opening of two blocks of the dam. These gauges may also be advantageously used for observation of opening or of closing of surface cracks at any location.

### ***Foundation displacement***

Measurement of vertical or horizontal displacement of foundation provides information for taking preventive measures for inclination, distortion etc. of structures. The data can also be used for studying the elastic and inelastic properties of dam and foundation. Measurement of foundation displacement involves vertical and horizontal displacement of part of foundation with respect to dam.

### ***Displacement of One Part of the Dam Relative to other Parts of the Dam***

Measurement of relative displacement of two points in a dam is a direct indication of structural behaviour of the dam. The deflection characteristics of a dam observed for the first few years will reveal any dangerous tilt or movement of the dam. These observations are made by regular and inverted plumbines. The plumbline data together with other supporting data may be used to study the elastic behaviour of the dam.

### ***Displacement of Dam with Reference to Surrounding Area***

This measurement gives the absolute displacement of the dam with respect to surrounding area, and is a direct indication of structural behaviour of the dam. Provisions would be made for periodic deflection measurements. Where topography permits, this can be done by theodolite from fixed bases, using either line-of-sight over the top of the dam or by turning angles to targets on the downstream face and at the crest. At concrete dams, the deflections should be consistent with changes in reservoir water surface level and in temperature and should not change appreciably from year to year.

### ***Measurement of Tilt***

Tilt is measurement of rotation in vertical plane. It is normally measured with the help of tiltmeter system consisting of tiltmeter sensor, tilt plates and indicator. Tilt plates are

bonded to the surface of mass of structure under observation. The sensor is oriented on three pegs of tilt plate and senses change in tilt of tilt plate. The portable indicator gives the degree of rotation.

### ***Measurement of Stress***

Direct measurement of stress developed inside the mass of concrete or masonry helps in watching the structural behaviour of dams and their foundations. Any adverse change in stress will indicate distress conditions and remedial measures can be taken. The observation of stress also helps in studying the assumed stresses and actual stresses in dams and this can be used in improving upon the design procedure.

### ***Measurement of Strain***

Factors like temperature, chemical action, moisture change and stress result in volume changes which cause strain in the structure. The measurement of strain, therefore, becomes necessary. As the design of structures is based on stress it is essential to measure the stresses developed in the structures during its life time. Moreover, the instruments available for measurement of stresses can measure only compressive stress and not the

tensile stress. Further, the stress measuring instruments are more expensive and delicate than strain meters and hence, it is a common practice to measure the strain and to calculate from it the developed stress.

### ***Measurement of Pore Pressure***

Since large concrete and masonry dams are provided with internal formed drains located near the upstream face, a record of pore pressure development and its variations would indicate the effectiveness and adequacy of these drains. Any sudden unusual increase in the pore pressures will be indicative of choking up of these internal drains and any unusual reduction from the normal would indicate possibility of formation of cracks or establishment of flow channels in the body of the dam. Measurement of uplift in the foundation is mandatory for all gravity dams and is generally accomplished by uplift pressure pipes which provide a direct indication of the prevailing magnitude of uplift resulting from the operating reservoir heads and consequently the effectiveness of the grout curtain close to the upstream face of the dam and effectiveness of the drainage curtain provided in the foundation apart from checking of design assumptions for its stability.

### ***Seismicity of the Area and Dynamic Characteristic of the Structure***

Surveillance of seismic environment of the project site needs special attention in case of large dams to know about the seismicity of the region before taking up construction. Creation of a reservoir generates additional load on the surrounding area and underlying geological strata. Thus, it becomes essential to know the change in the seismicity pattern, if any, due to creation of large reservoir. The behaviour of dam during an earthquake also needs to be assessed. For these purposes, a seismological laboratory may be established near the project site.

### Measurement of Water Level on Upstream and Downstream Side

This measurement is useful for calculating the water pressure on the upstream face and downstream face of the dam.

A typical set of piezometer installations for an embankment dam is shown in Figure 45.

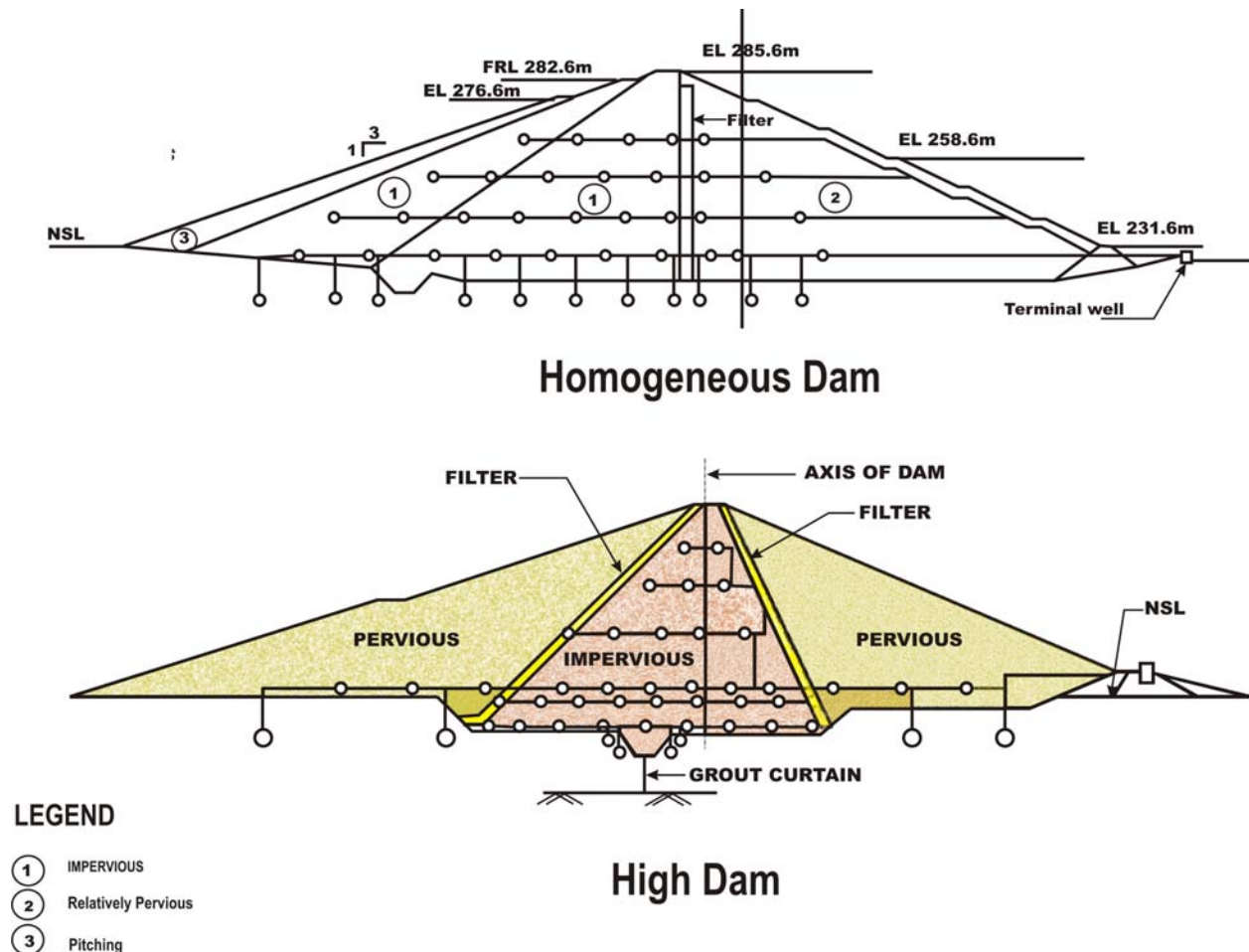

FIGURE 45. Typical installation of piezometers in embankment dams

### 4.6.11 Structural design of special components

Although maximum value of concrete in gravity dam construction goes into mass concreting, reinforcements are required at some places for resisting tensile stresses. Of these two components are quite important: Galleries and spillway piles. The Bureau of Indian Standards has brought out two codes on the structural design of these components and they are as follows;

1. IS: 12966(Part 2)-1990 “Code of practice for galleries and other openings in dams” (Part 2: Structural design)
2. IS: 13551-1992 “Structural design of spillway piers and crest–criteria”

Though the details may be found in the above code it may be mentioned that galleries are openings in the body of the dam that introduce stress concentration in its surroundings. This concentration would be minimum if the openings are circular or nearly so. But for ease of operation, the galleries are mostly rectangular thus accentuating the stress concentration at the corners. Hence reinforcement has to be provided all round the openings, and special care taken where two openings meet, say at the junction of the foundation gallery and an inspection adit. Is 12966(part 2) -1990 gives guidelines for both evaluating the stresses and design of reinforcements. It also illustrates typical layout of placing reinforcements.

As for the spillway piers, they are erected over the crest profile and are provided to divide the spillway into a number of bays so as to control the flow over the spillway by installing gates between two piers. Piers are also used to support the bridge over the spillway for the movement of the gantry crane and normal traffic. IS 13551-1992 helps to identify the forces acting on a pier and method to compute the induced moments and stresses. It also illustrates typical layout of reinforcement in a pier and its junction with the spillway crest.

It may be noted that all reinforced concrete works in concrete dams have to conform to IS 456-2000 “code of practice for plain and reinforced concrete”. The following two Bureau of Indian Standard codes may also be referred to for further details related to training walls, divide walls and spillway anchorages.

1. IS 12720-1992 “Criteria for structural design of spillway training and divide walls”
2. IS 95-1993 “Design aid for anchorages for spillway structures”