

Lecture 6

Mohr's Circle for Plane Stress

Transformation equations for plane stress.

Procedure for constructing Mohr's circle.

Stresses on an inclined element.

Principal stresses and maximum shear stresses.

Introduction to the stress tensor.

Stress Transformation Equations

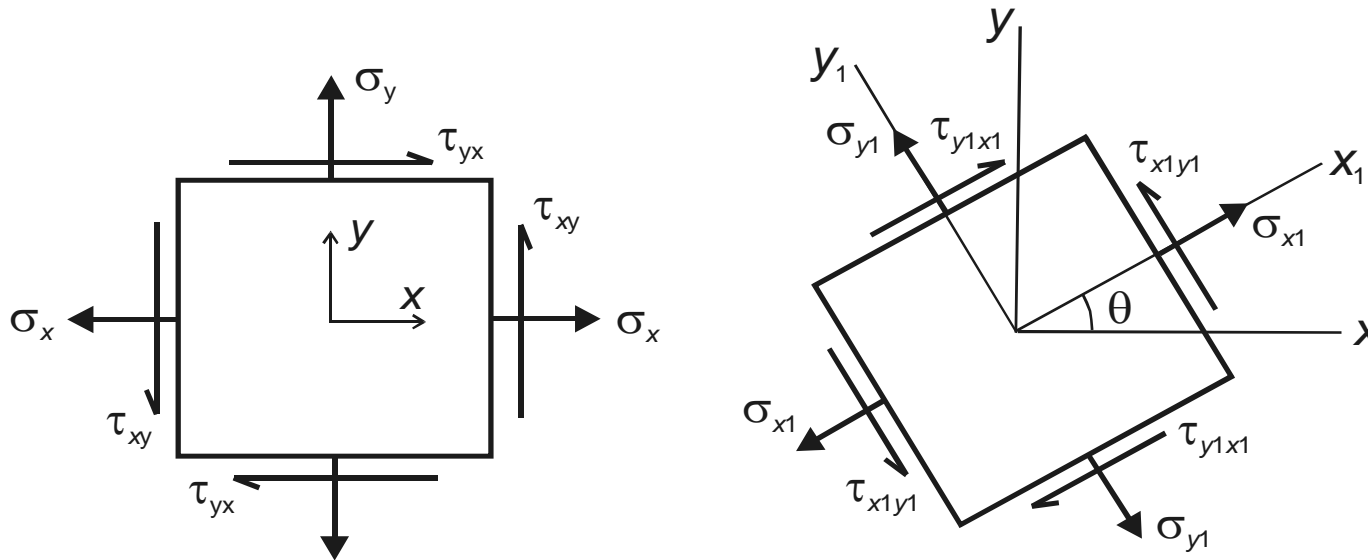

$$\sigma_{x1} = \frac{\sigma_x + \sigma_y}{2} + \frac{\sigma_x - \sigma_y}{2} \cos 2\theta + \tau_{xy} \sin 2\theta$$

$$\tau_{x1y1} = -\frac{(\sigma_x - \sigma_y)}{2} \sin 2\theta + \tau_{xy} \cos 2\theta$$

If we vary θ from 0° to 360° , we will get all possible values of σ_{x1} and τ_{x1y1} for a given stress state. It would be useful to represent σ_{x1} and τ_{x1y1} as functions of θ in graphical form.

To do this, we must re-write the transformation equations.

$$\sigma_{x1} - \frac{\sigma_x + \sigma_y}{2} = \frac{\sigma_x - \sigma_y}{2} \cos 2\theta + \tau_{xy} \sin 2\theta$$
$$\tau_{x1y1} = -\frac{(\sigma_x - \sigma_y)}{2} \sin 2\theta + \tau_{xy} \cos 2\theta$$

Eliminate θ by squaring both sides of each equation and adding the two equations together.

$$\left(\sigma_{x1} - \frac{\sigma_x + \sigma_y}{2} \right)^2 + \tau_{x1y1}^2 = \left(\frac{\sigma_x - \sigma_y}{2} \right)^2 + \tau_{xy}^2$$

Define σ_{avg} and R

$$\sigma_{avg} = \frac{\sigma_x + \sigma_y}{2} \quad R = \sqrt{\left(\frac{\sigma_x - \sigma_y}{2} \right)^2 + \tau_{xy}^2}$$

Substitute for σ_{avg} and R to get

$$\left(\sigma_{x1} - \sigma_{avg}\right)^2 + \tau_{x1y1}^2 = R^2$$

which is the equation for a **circle** with centre $(\sigma_{avg}, 0)$ and radius R .

This circle is usually referred to as **Mohr's circle**, after the German civil engineer Otto Mohr (1835-1918). He developed the graphical technique for drawing the circle in 1882.

The construction of Mohr's circle is one of the few graphical techniques still used in engineering. It provides a simple and clear picture of an otherwise complicated analysis.

Sign Convention for Mohr's Circle

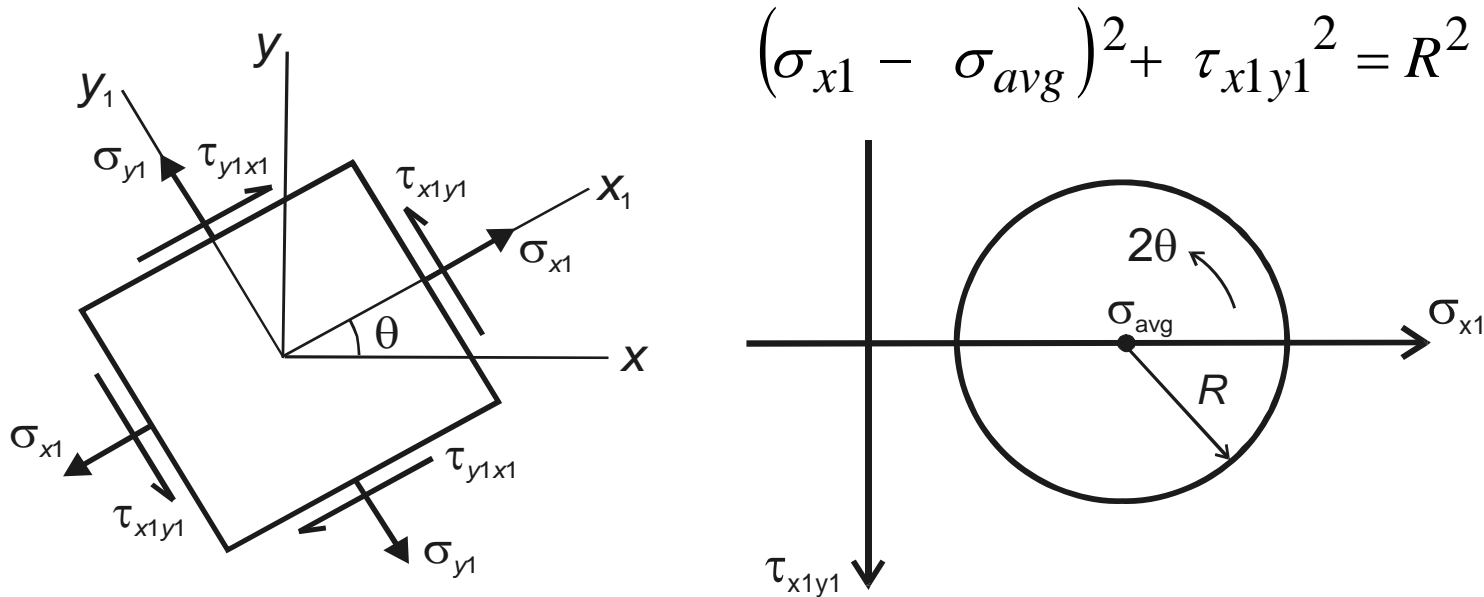

Notice that shear stress is plotted as positive downward.

The reason for doing this is that 2θ is then positive counterclockwise, which agrees with the direction of 2θ used in the derivation of the transformation equations and the direction of θ on the stress element.

Notice that although 2θ appears in Mohr's circle, θ appears on the stress element.

Procedure for Constructing Mohr's Circle

1. Draw a set of coordinate axes with σ_{x1} as abscissa (positive to the right) and τ_{x1y1} as ordinate (positive downward).
2. Locate the centre of the circle c at the point having coordinates $\sigma_{x1} = \sigma_{avg}$ and $\tau_{x1y1} = 0$.
3. Locate point A , representing the stress conditions on the x face of the element by plotting its coordinates $\sigma_{x1} = \sigma_x$ and $\tau_{x1y1} = \tau_{xy}$. Note that point A on the circle corresponds to $\theta = 0^\circ$.
4. Locate point B , representing the stress conditions on the y face of the element by plotting its coordinates $\sigma_{x1} = \sigma_y$ and $\tau_{x1y1} = -\tau_{xy}$. Note that point B on the circle corresponds to $\theta = 90^\circ$.
5. Draw a line from point A to point B , a diameter of the circle passing through point c . Points A and B (representing stresses on planes at 90° to each other) are at opposite ends of the diameter (and therefore 180° apart on the circle).
6. Using point c as the centre, draw Mohr's circle through points A and B . This circle has radius R .

(based on Gere)

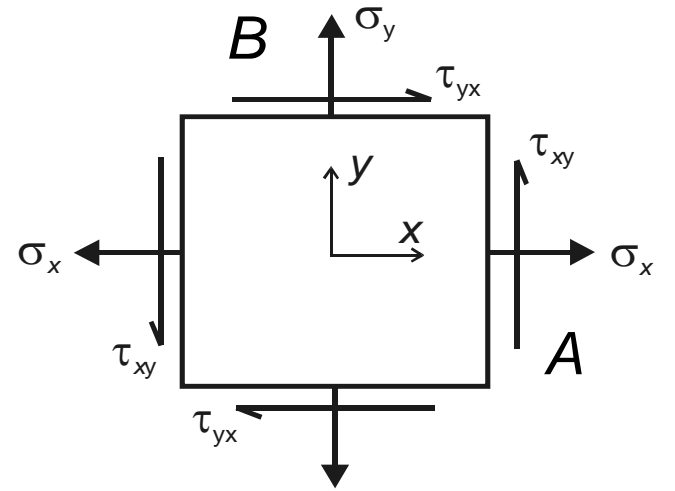
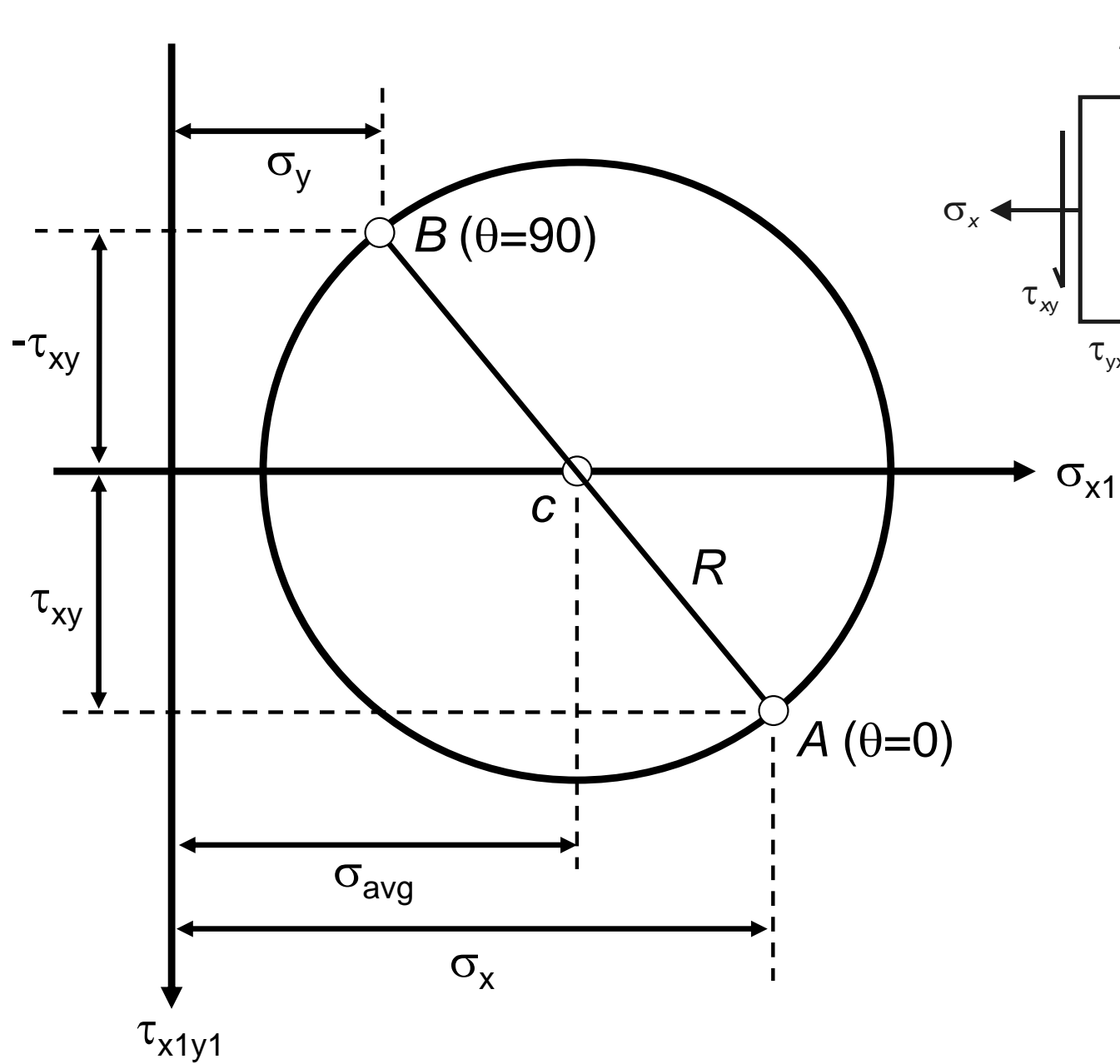

Stresses on an Inclined Element

1. On Mohr's circle, measure an angle 2θ counterclockwise from radius cA , because point A corresponds to $\theta = 0$ and hence is the reference point from which angles are measured.
2. The angle 2θ locates the point D on the circle, which has coordinates σ_{x1} and τ_{x1y1} . Point D represents the stresses on the $x1$ face of the inclined element.
3. Point E , which is diametrically opposite point D on the circle, is located at an angle $2\theta + 180^\circ$ from cA (and 180° from cD). Thus point E gives the stress on the $y1$ face of the inclined element.
4. So, as we rotate the $x1y1$ axes counterclockwise by an angle θ , the point on Mohr's circle corresponding to the $x1$ face moves counterclockwise through an angle 2θ .

(based on Gere)

Principal Stresses

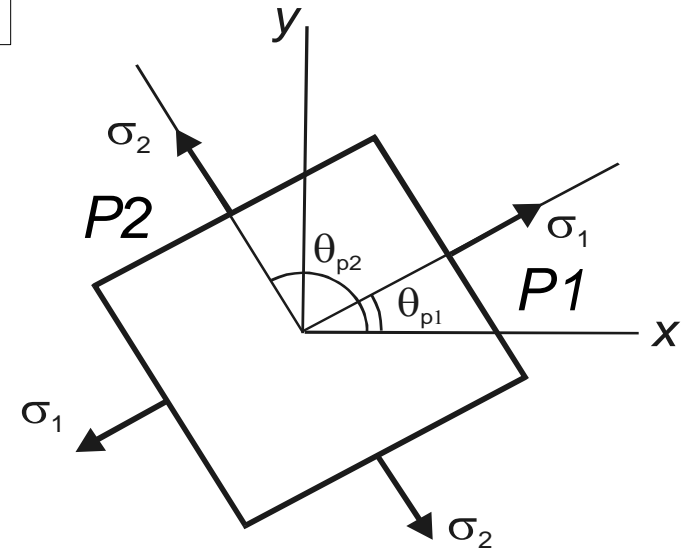
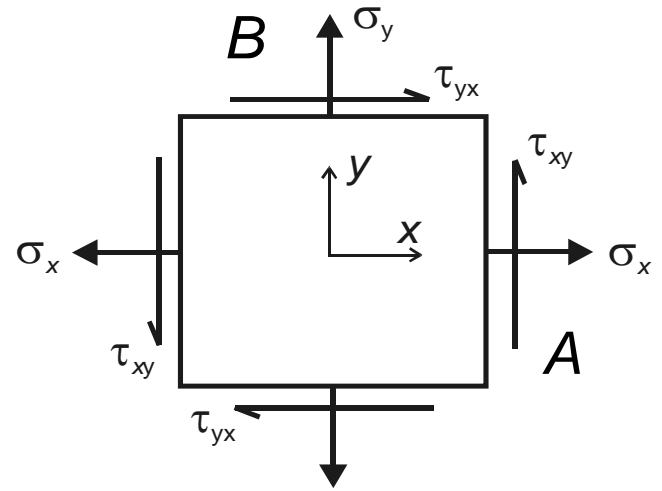
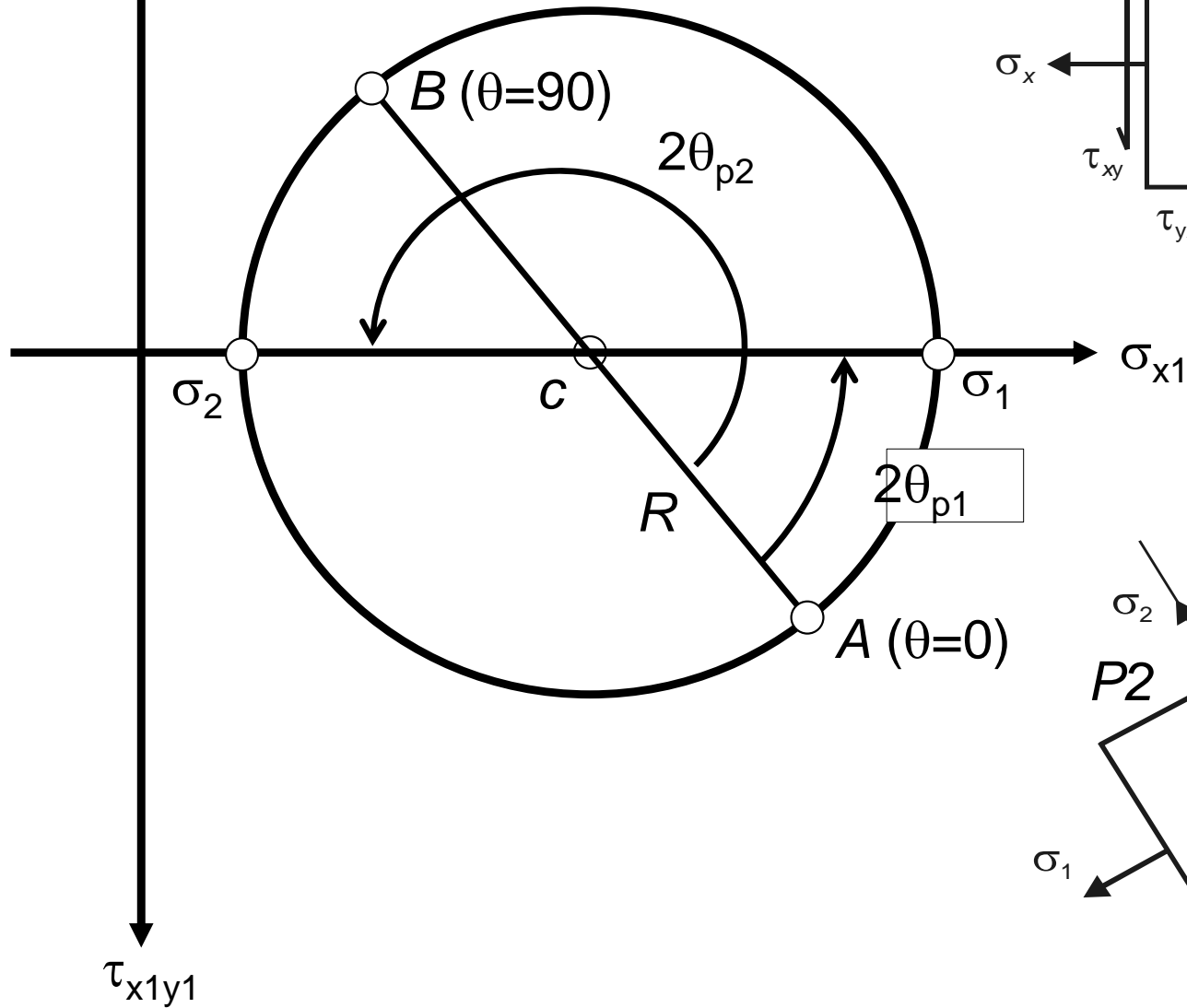

Maximum Shear Stress

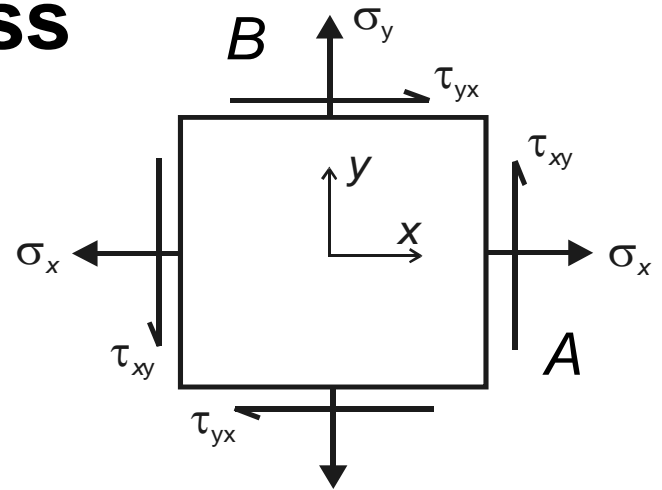
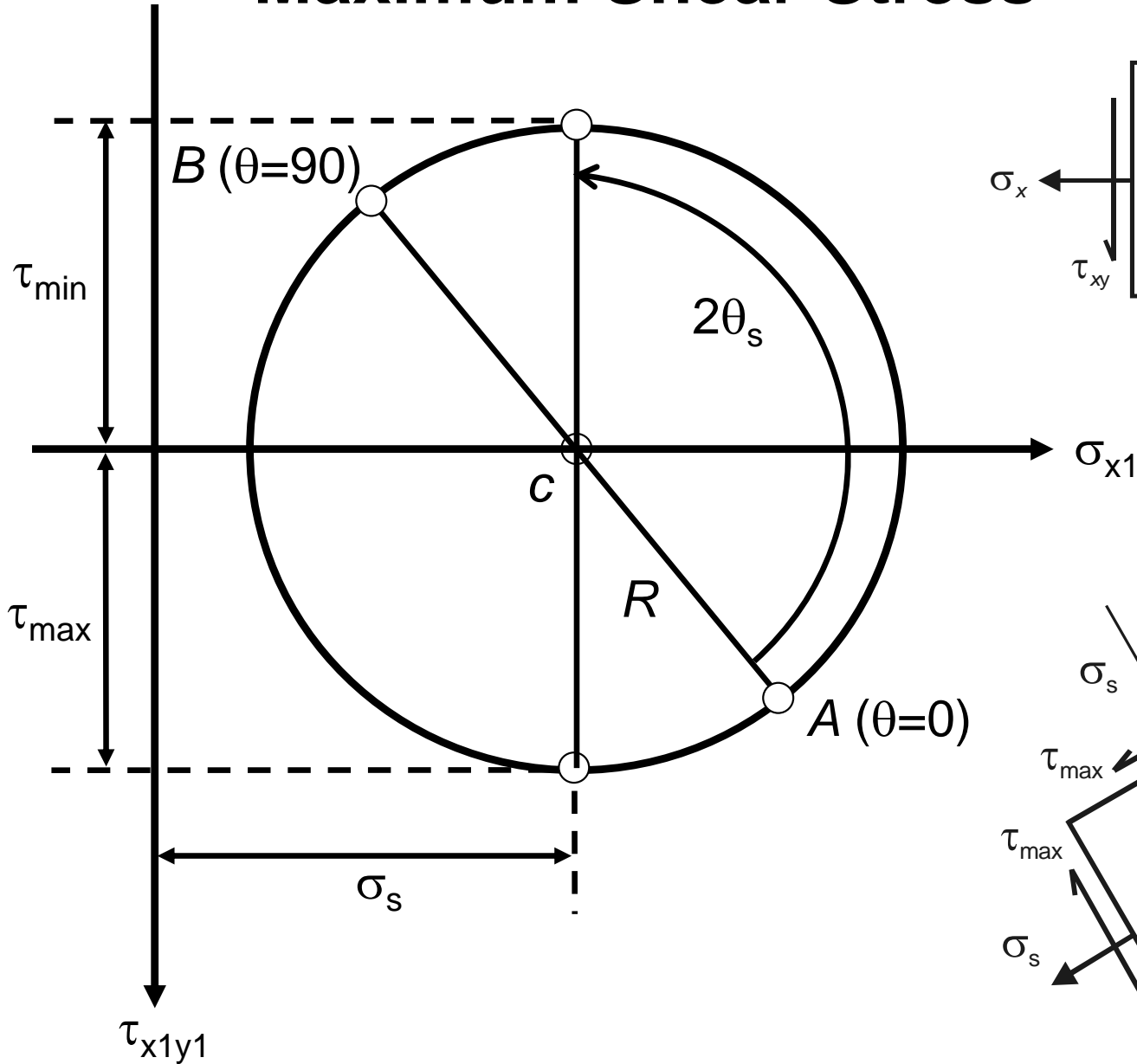

Note carefully the directions of the shear forces.

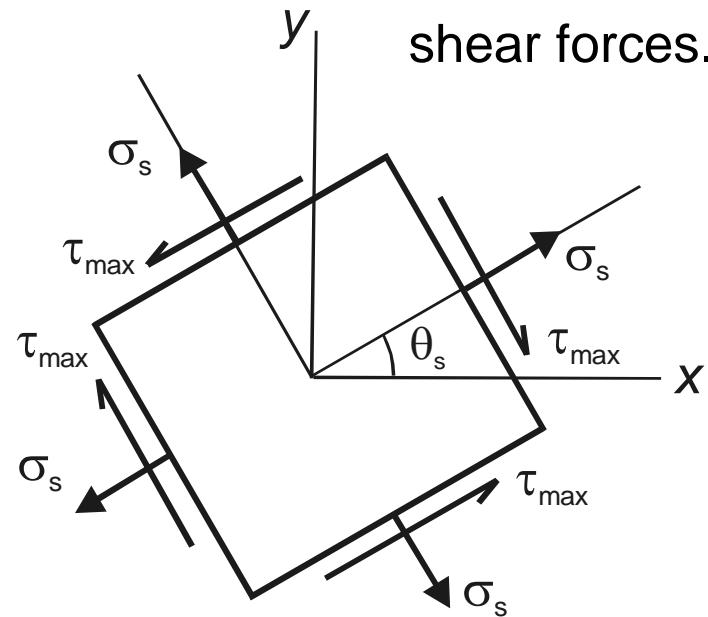

Example: The state of plane stress at a point is represented by the stress element below. Draw the Mohr's circle, determine the principal stresses and the maximum shear stresses, and draw the corresponding stress elements.

$$c = \sigma_{avg} = \frac{\sigma_x + \sigma_y}{2} = \frac{-80 + 50}{2} = -15$$

$$R = \sqrt{(50 - (-15))^2 + (25)^2}$$

$$R = \sqrt{65^2 + 25^2} = 69.6$$

$$\sigma_{1,2} = c \pm R$$

$$\sigma_{1,2} = -15 \pm 69.6$$

$$\sigma_1 = 54.6 \text{ MPa}$$

$$\sigma_2 = -84.6 \text{ MPa}$$

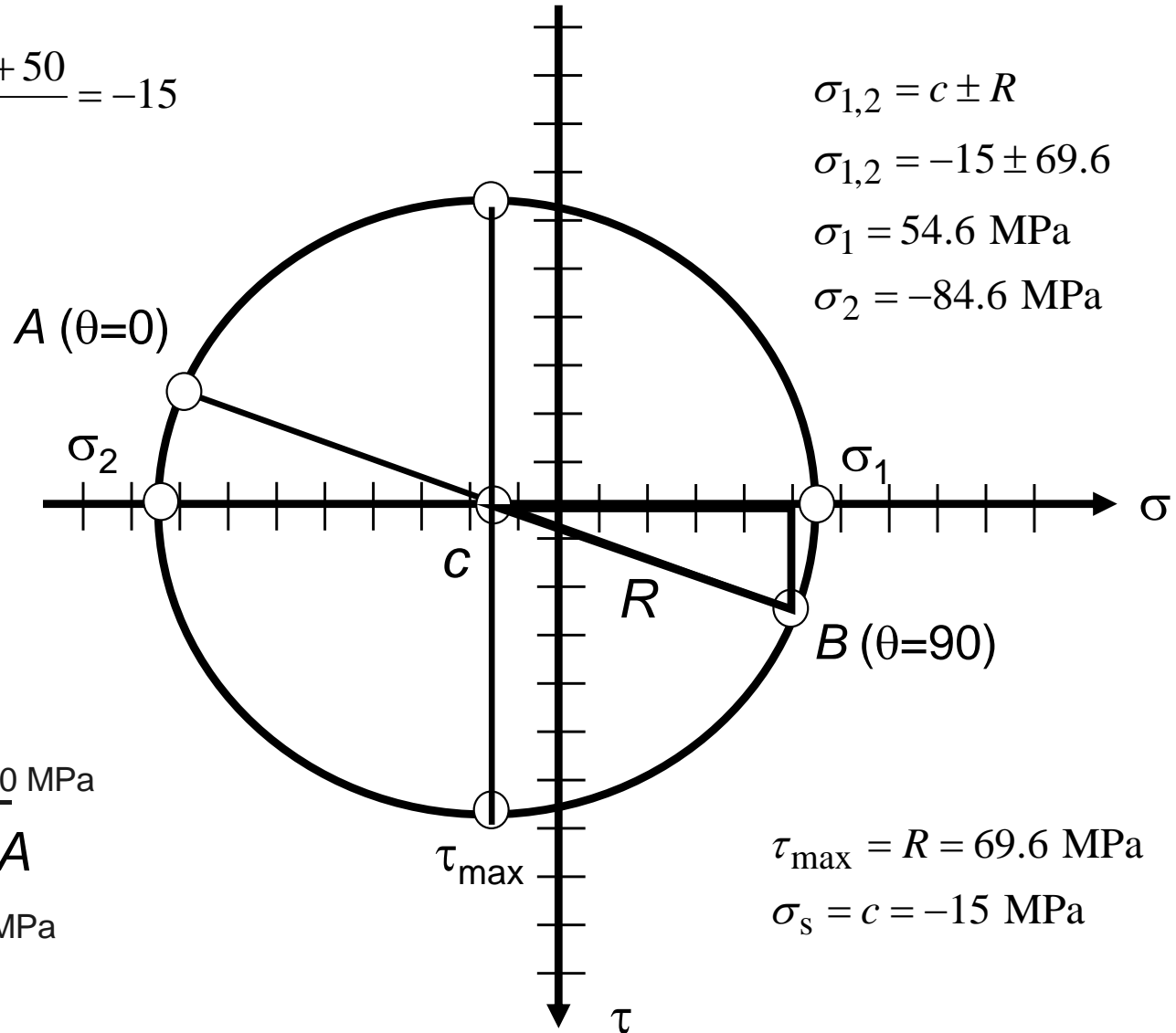
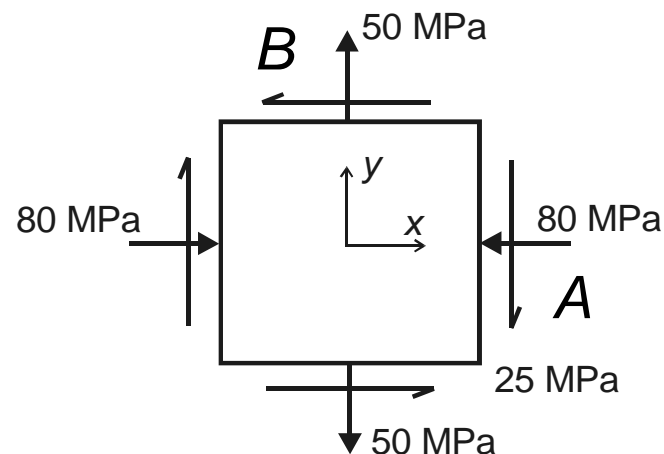

$$\tau_{max} = R = 69.6 \text{ MPa}$$

$$\sigma_s = c = -15 \text{ MPa}$$

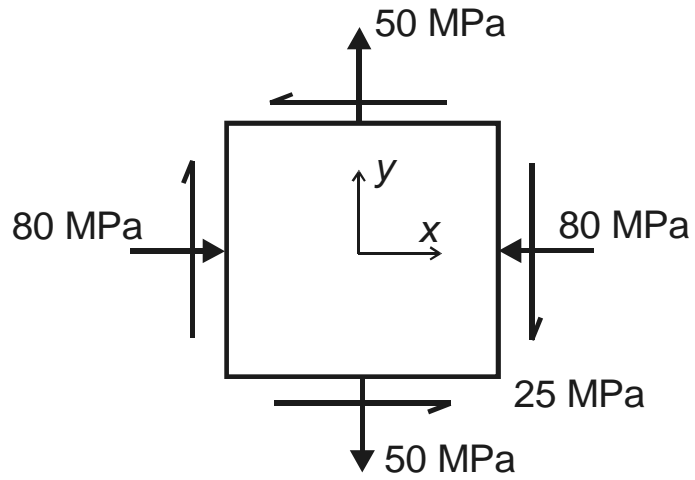

$$\tan 2\theta_2 = \frac{25}{80 - 15} = 0.3846$$

$$2\theta_2 = 21.0^\circ$$

$$2\theta_1 = 21.0 + 180^\circ = 201^\circ$$

$$\theta_1 = 100.5^\circ \quad \theta_2 = 10.5^\circ$$

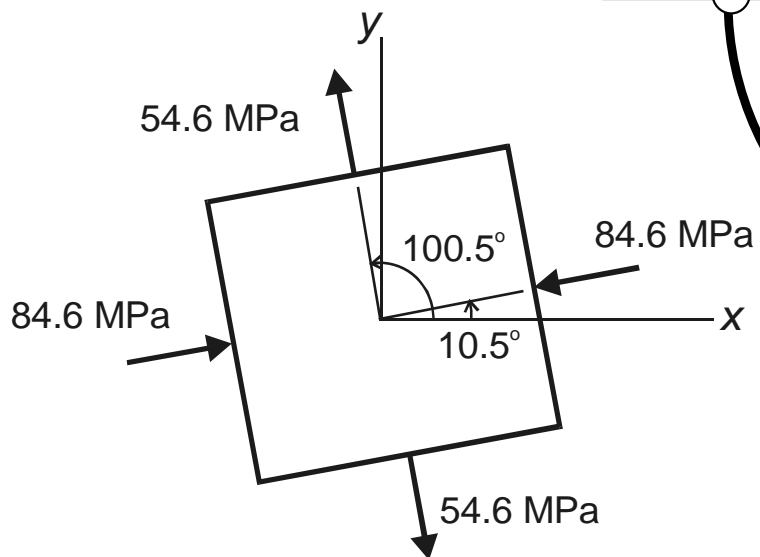
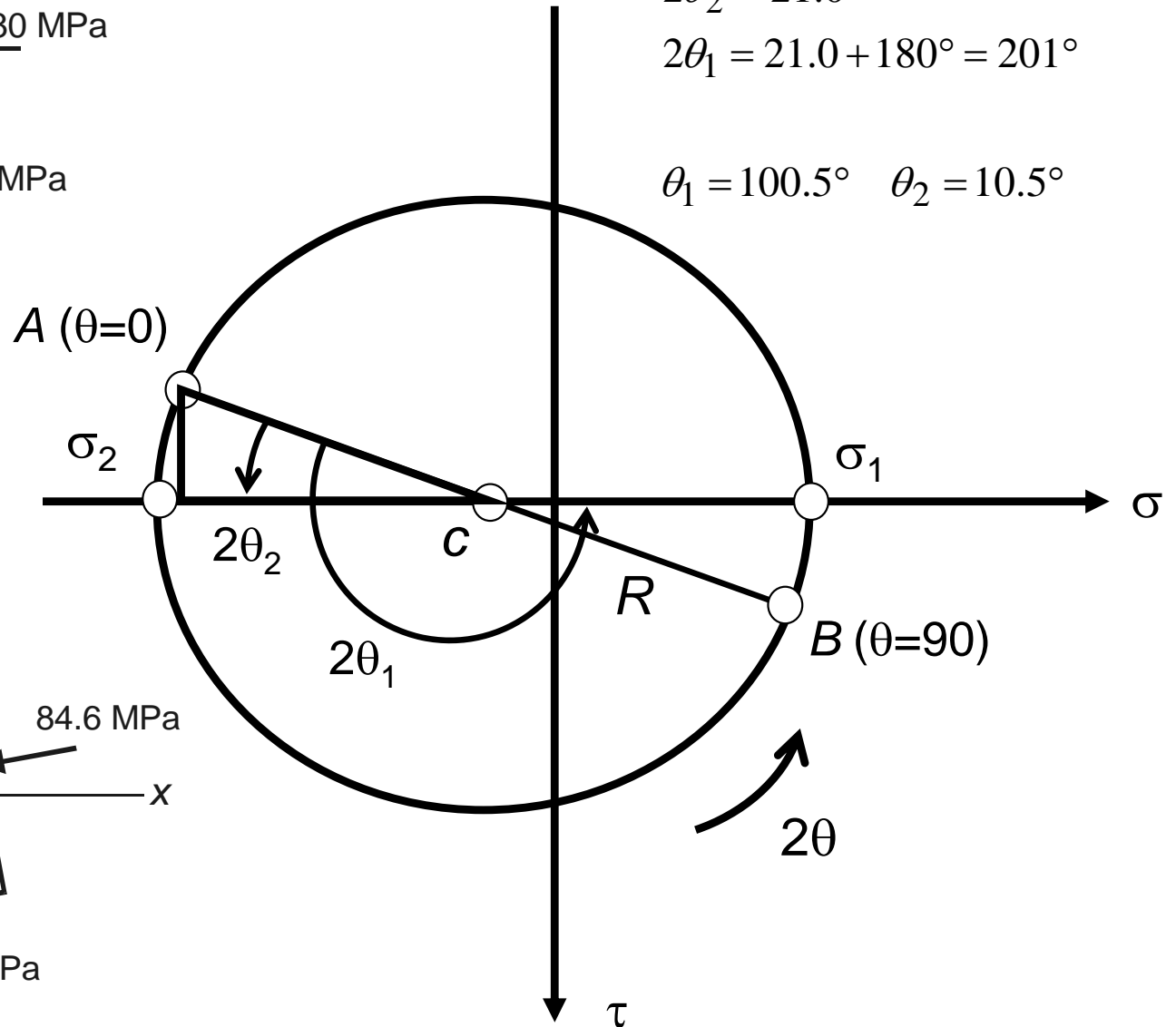

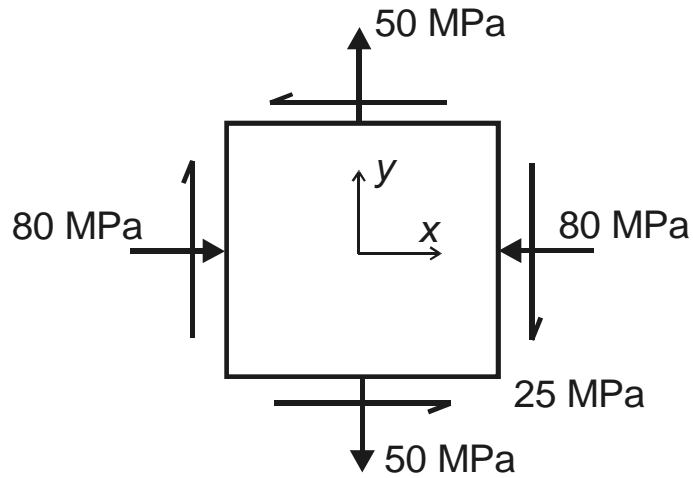

$$2\theta_2 = 21.0^\circ$$

$$2\theta_{s\min} = -(90 - 21.0) = -69.0^\circ$$

$$\theta_{s\min} = -34.5^\circ$$

taking sign convention into account

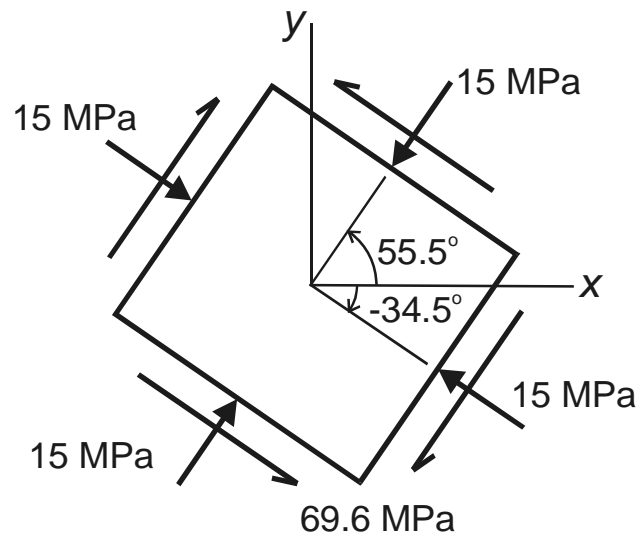
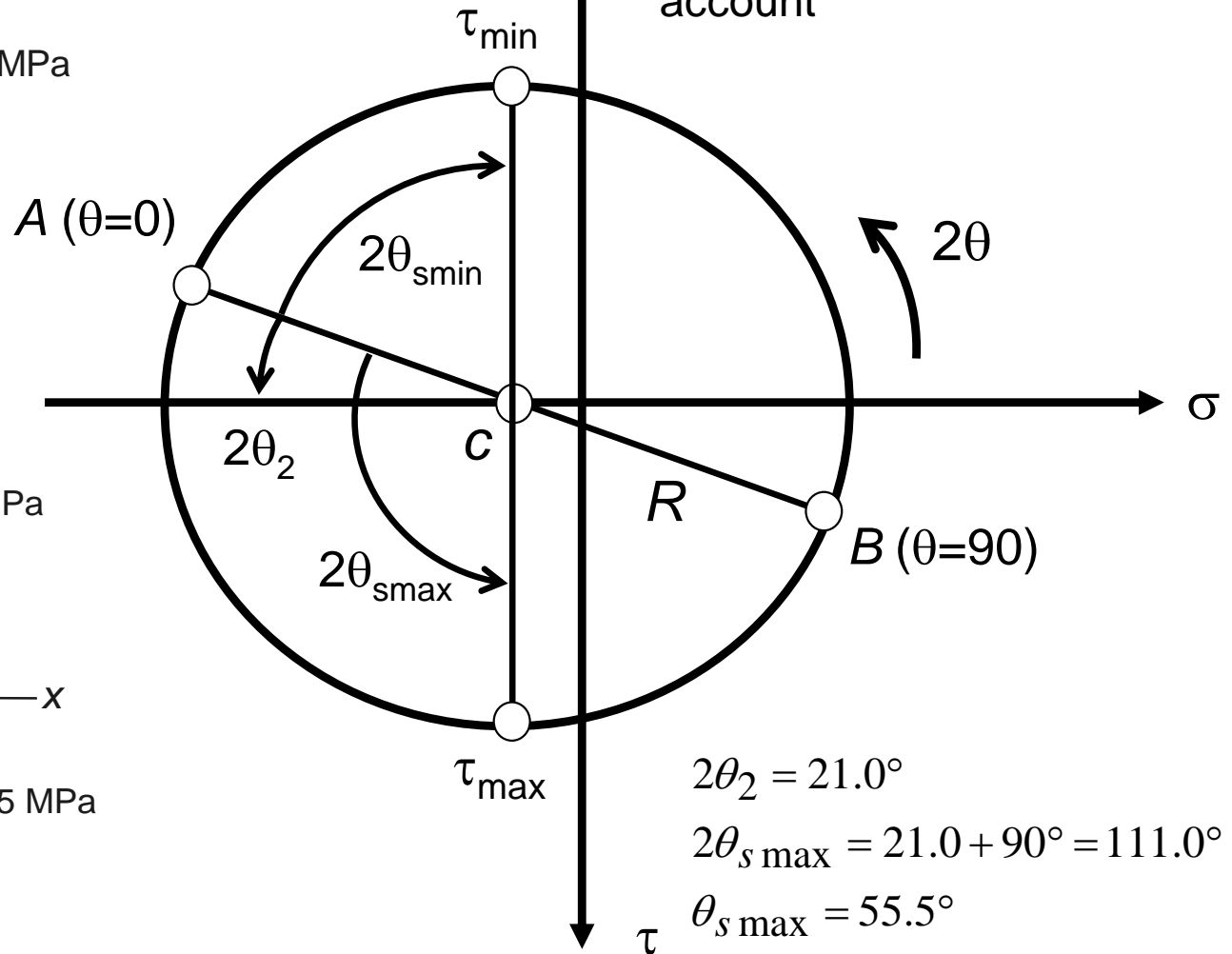

$$2\theta_2 = 21.0^\circ$$

$$2\theta_{s\max} = 21.0 + 90^\circ = 111.0^\circ$$

$$\theta_{s\max} = 55.5^\circ$$

Example: The state of plane stress at a point is represented by the stress element below. Find the stresses on an element inclined at 30° clockwise and draw the corresponding stress elements.

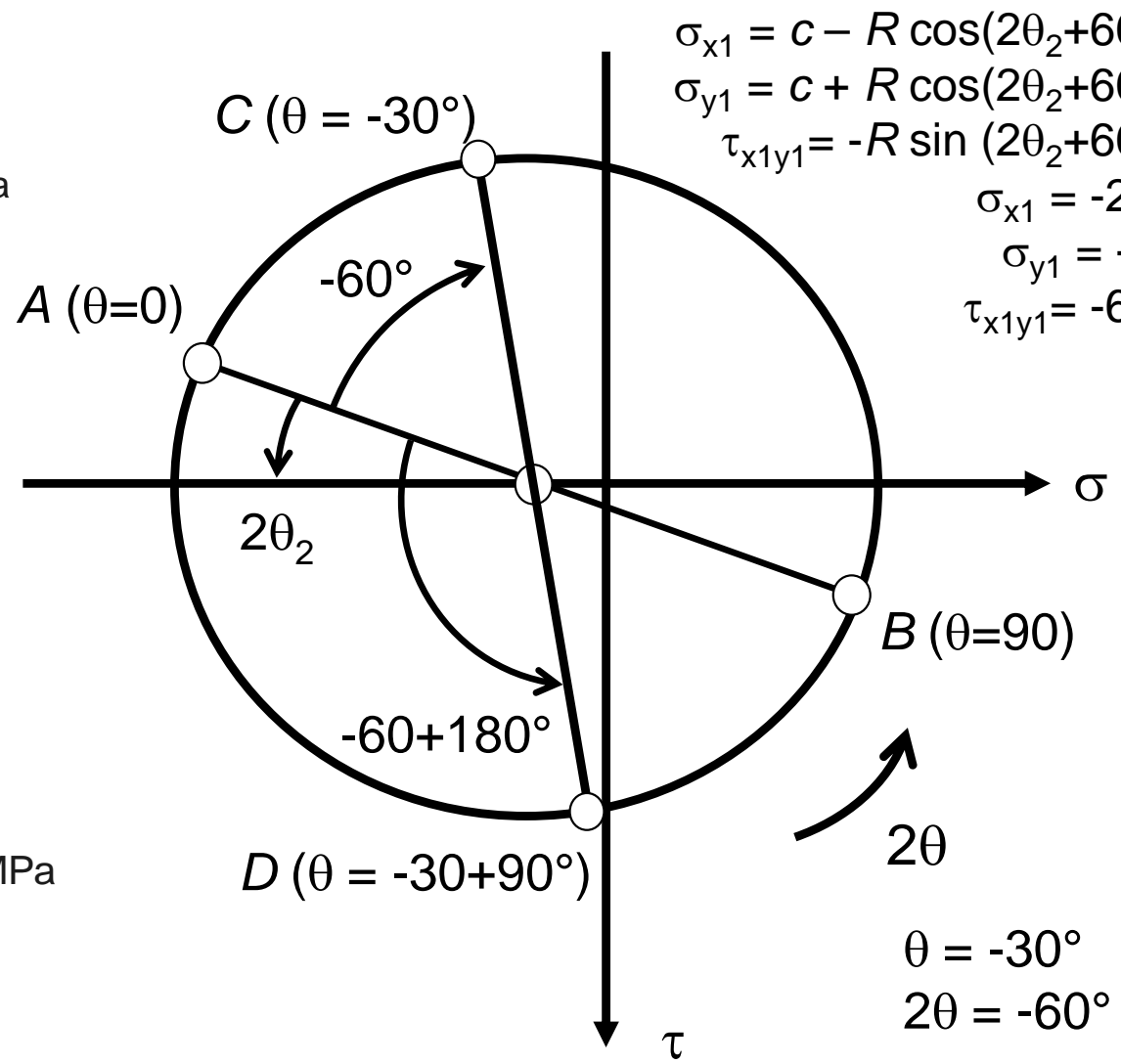
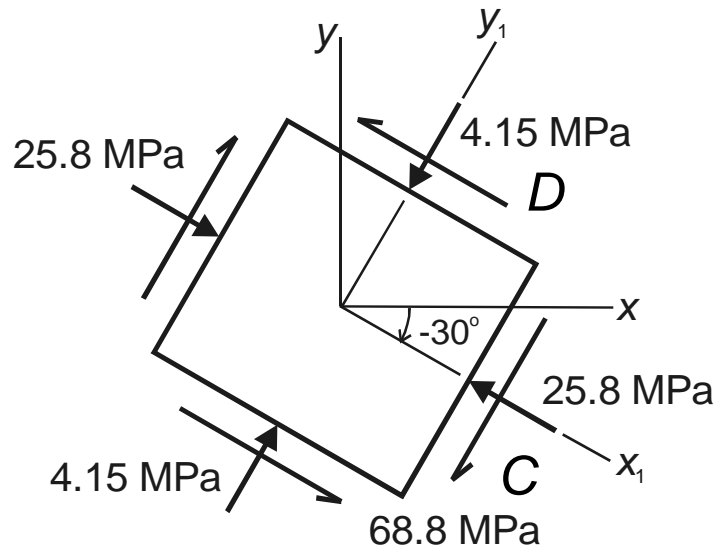
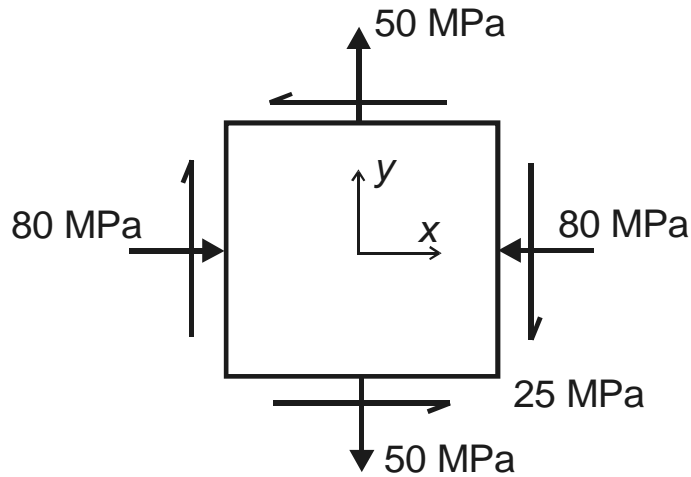

$$\begin{aligned} \sigma_{x_1} &= c - R \cos(2\theta_2 + 60) \\ \sigma_{y_1} &= c + R \cos(2\theta_2 + 60) \\ \tau_{x_1y_1} &= -R \sin(2\theta_2 + 60) \end{aligned}$$

$$\begin{aligned} \sigma_{x_1} &= -26 \\ \sigma_{y_1} &= -4 \\ \tau_{x_1y_1} &= -69 \end{aligned}$$

$$\begin{aligned} \theta &= -30^\circ \\ 2\theta &= -60^\circ \end{aligned}$$

Principal Stresses $\sigma_1 = 54.6$ MPa, $\sigma_2 = -84.6$ MPa

But we have forgotten about the third principal stress!

Since the element is in plane stress ($\sigma_z = 0$),
the third principal stress is zero.

$\sigma_1 = 54.6$ MPa
 $\sigma_2 = 0$ MPa
 $\sigma_3 = -84.6$ MPa

This means three
Mohr's circles can
be drawn, each
based on two
principal stresses:

σ_1 and σ_3

σ_1 and σ_2

σ_2 and σ_3

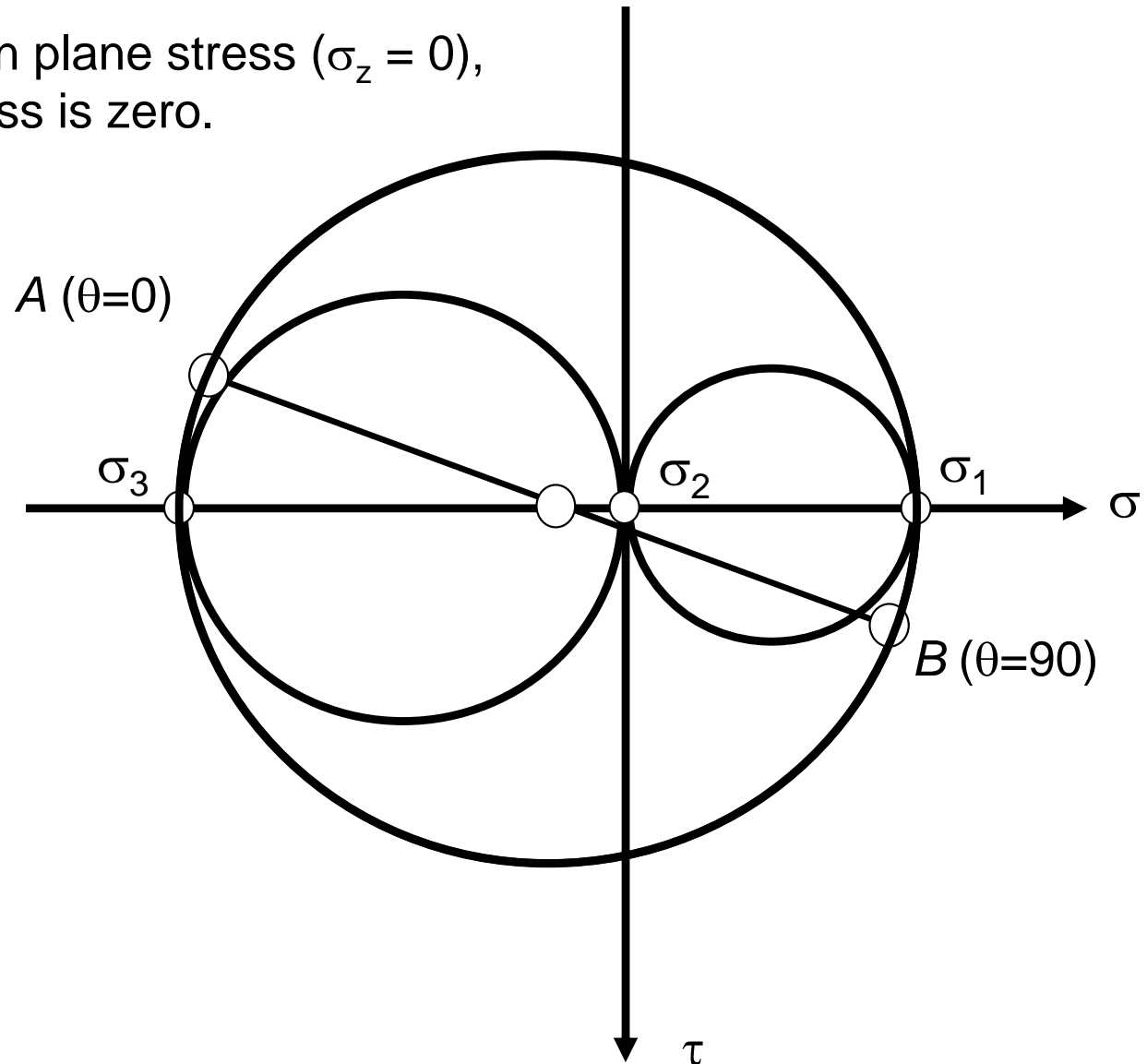

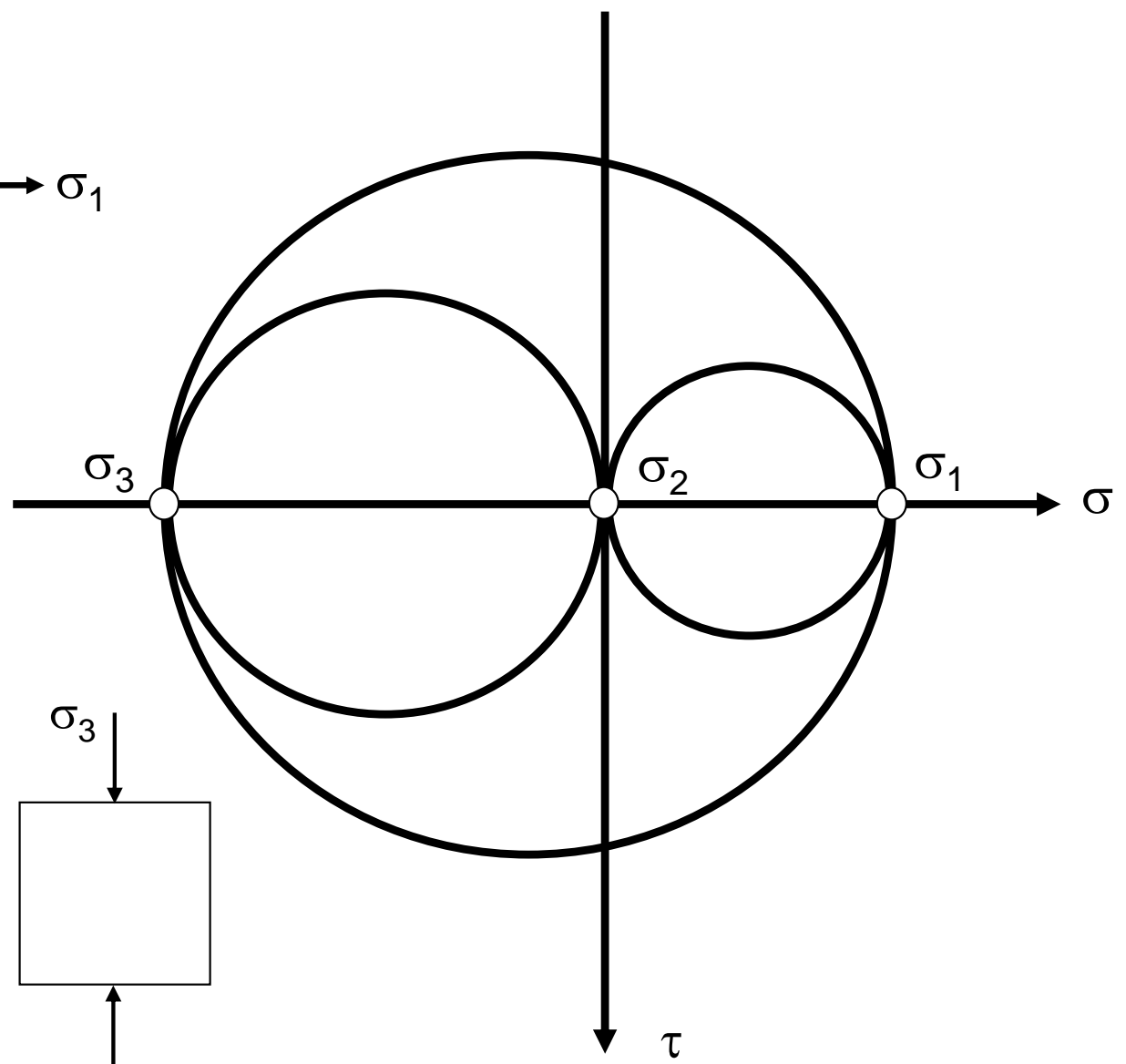
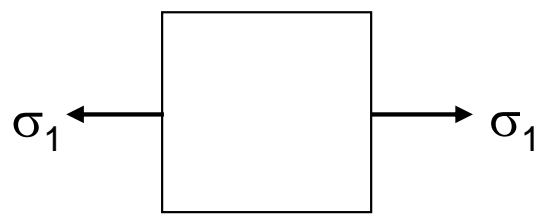
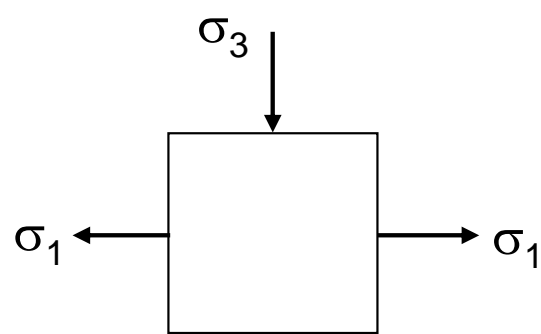
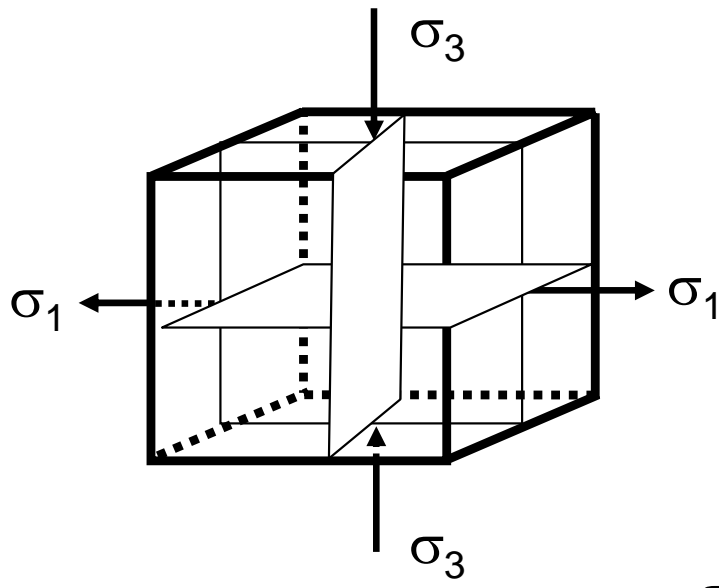

The stress element shown is in plane stress.
 What is the maximum shear stress?

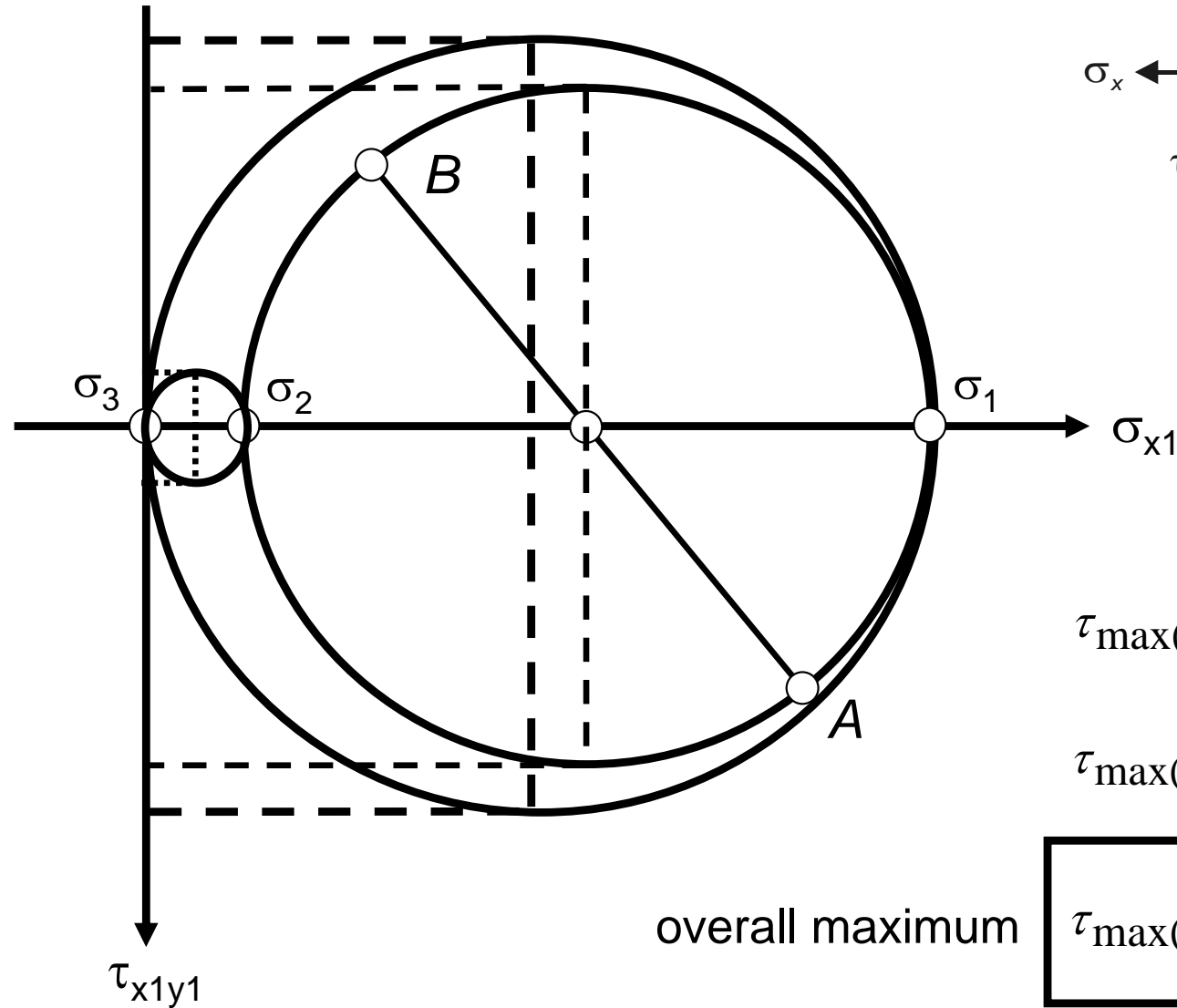
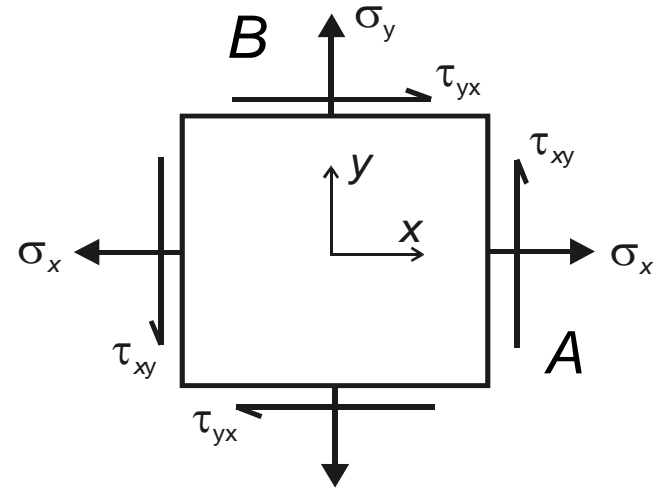

$$\tau_{\max(1,2)} = \frac{\sigma_1 - \sigma_2}{2}$$

$$\tau_{\max(2,3)} = \frac{\sigma_2 - \sigma_3}{2} = \frac{\sigma_2}{2}$$

$$\tau_{\max(1,3)} = \frac{\sigma_1 - \sigma_3}{2} = \frac{\sigma_1}{2}$$

Introduction to the Stress Tensor

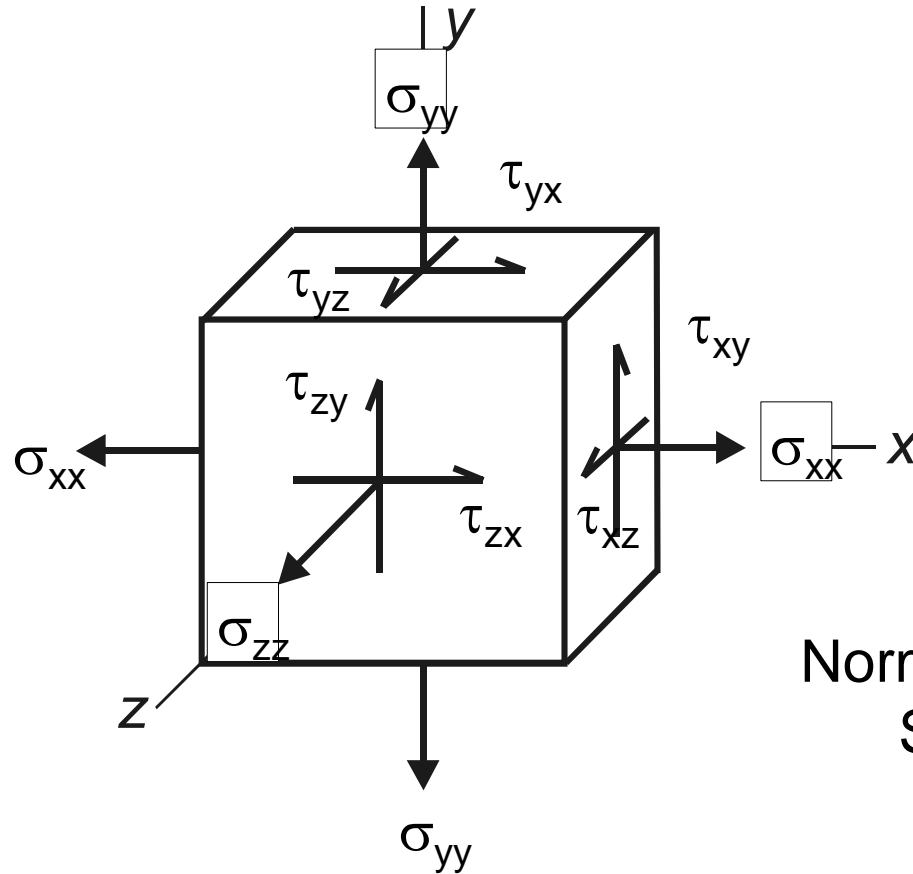

$$\begin{pmatrix} \sigma_{xx} & \tau_{xy} & \tau_{xz} \\ \tau_{yx} & \sigma_{yy} & \tau_{yz} \\ \tau_{zx} & \tau_{zy} & \sigma_{zz} \end{pmatrix}$$

Normal stresses on the diagonal
Shear stresses off diagonal

$$\tau_{xy} = \tau_{yx}, \tau_{xz} = \tau_{zx}, \tau_{yz} = \tau_{zy}$$

The normal and shear stresses on a stress element in 3D can be assembled into a 3x3 matrix known as the **stress tensor**.

From our analyses so far, we know that for a given stress system, it is possible to find a set of three principal stresses. We also know that if the principal stresses are acting, the shear stresses must be zero. In terms of the stress tensor,

$$\begin{pmatrix} \sigma_{xx} & \tau_{xy} & \tau_{xz} \\ \tau_{yx} & \sigma_{yy} & \tau_{yz} \\ \tau_{zx} & \tau_{zy} & \sigma_{zz} \end{pmatrix} \longrightarrow \begin{pmatrix} \sigma_1 & 0 & 0 \\ 0 & \sigma_2 & 0 \\ 0 & 0 & \sigma_3 \end{pmatrix}$$

In mathematical terms, this is the process of matrix diagonalization in which the eigenvalues of the original matrix are just the principal stresses.

Example: The state of plane stress at a point is represented by the stress element below. Find the principal stresses.

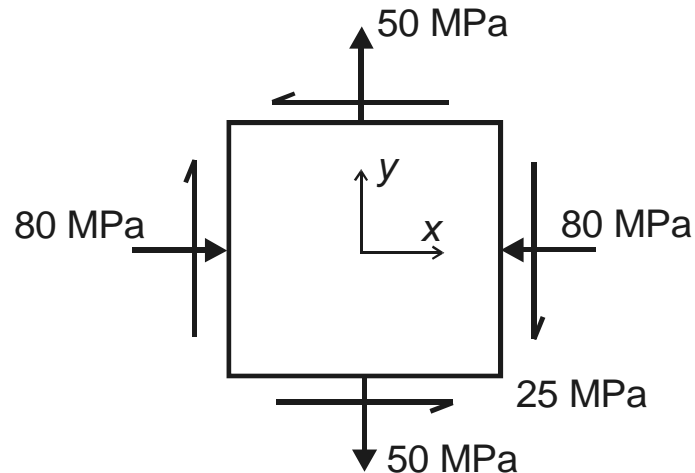

$$M = \begin{pmatrix} \sigma_x & \tau_{xy} \\ \tau_{yx} & \sigma_y \end{pmatrix} = \begin{pmatrix} -80 & -25 \\ -25 & 50 \end{pmatrix}$$

We must find the eigenvalues of this matrix.

Remember the general idea of eigenvalues. We are looking for values of λ such that:

$A\mathbf{r} = \lambda\mathbf{r}$ where \mathbf{r} is a vector, and A is a matrix.

$A\mathbf{r} - \lambda\mathbf{r} = \mathbf{0}$ or $(A - \lambda I)\mathbf{r} = \mathbf{0}$ where I is the identity matrix.

For this equation to be true, either $\mathbf{r} = \mathbf{0}$ or $\det(A - \lambda I) = 0$. Solving the latter equation (the “characteristic equation”) gives us the eigenvalues λ_1 and λ_2 .

$$\det \begin{pmatrix} -80 - \lambda & -25 \\ -25 & 50 - \lambda \end{pmatrix} = 0$$

$$(-80 - \lambda)(50 - \lambda) - (-25)(-25) = 0$$

$$\lambda^2 + 30\lambda - 4625 = 0$$

$$\lambda = -84.6, 54.6$$

So, the principal stresses are -84.6 MPa and 54.6 MPa, as before.

Knowing the eigenvalues, we can find the eigenvectors. These can be used to find the angles at which the principal stresses act. To find the eigenvectors, we substitute the eigenvalues into the equation $(A - \lambda I) \mathbf{r} = \mathbf{0}$ one at a time and solve for \mathbf{r} .

$$\begin{pmatrix} -80 - \lambda & -25 \\ -25 & 50 - \lambda \end{pmatrix} \begin{pmatrix} x \\ y \end{pmatrix} = \begin{pmatrix} 0 \\ 0 \end{pmatrix}$$

$$\begin{pmatrix} -134.6 & -25 \\ -25 & -4.64 \end{pmatrix} \begin{pmatrix} x \\ y \end{pmatrix} = \begin{pmatrix} 0 \\ 0 \end{pmatrix}$$

$$\begin{pmatrix} -80 - 54.6 & -25 \\ -25 & 50 - 54.6 \end{pmatrix} \begin{pmatrix} x \\ y \end{pmatrix} = \begin{pmatrix} 0 \\ 0 \end{pmatrix}$$

$$x = -0.186y$$

$$\begin{pmatrix} -0.186 \\ 1 \end{pmatrix} \text{ is one eigenvector.}$$

$$\begin{pmatrix} -80 - \lambda & -25 \\ -25 & 50 - \lambda \end{pmatrix} \begin{pmatrix} x \\ y \end{pmatrix} = \begin{pmatrix} 0 \\ 0 \end{pmatrix}$$

$$\begin{pmatrix} 4.6 & -25 \\ -25 & 134.6 \end{pmatrix} \begin{pmatrix} x \\ y \end{pmatrix} = \begin{pmatrix} 0 \\ 0 \end{pmatrix}$$

$$\begin{pmatrix} -80 - (-84.6) & -25 \\ -25 & 50 - (-84.6) \end{pmatrix} \begin{pmatrix} x \\ y \end{pmatrix} = \begin{pmatrix} 0 \\ 0 \end{pmatrix}$$

$$x = 5.388y$$

$$\begin{pmatrix} 5.388 \\ 1 \end{pmatrix} \text{ is the other eigenvector.}$$

Before finding the angles at which the principal stresses act, we can check to see if the eigenvectors are correct.

$$D = \begin{pmatrix} 54.6 & 0 \\ 0 & -84.6 \end{pmatrix} \quad C = \begin{pmatrix} -0.186 & 5.388 \\ 1 & 1 \end{pmatrix} \quad M = \begin{pmatrix} -80 & -25 \\ -25 & 50 \end{pmatrix}$$

$$D = C^{-1} M C$$

$$C^{-1} = \frac{1}{\det C} A^T \quad \text{where } A = \text{matrix of co-factors}$$

$$C^{-1} = \begin{pmatrix} -0.179 & 0.967 \\ 0.179 & 0.033 \end{pmatrix}$$

$$D = \begin{pmatrix} -0.179 & 0.967 \\ 0.179 & 0.033 \end{pmatrix} \begin{pmatrix} -80 & -25 \\ -25 & 50 \end{pmatrix} \begin{pmatrix} -0.186 & 5.388 \\ 1 & 1 \end{pmatrix} = \begin{pmatrix} 54.6 & 0 \\ 0 & -84.6 \end{pmatrix}$$

To find the angles, we must calculate the **unit** eigenvectors:

$$\begin{pmatrix} -0.186 \\ 1 \end{pmatrix} \rightarrow \begin{pmatrix} -0.183 \\ 0.983 \end{pmatrix} \quad \begin{pmatrix} 5.388 \\ 1 \end{pmatrix} \rightarrow \begin{pmatrix} 0.938 \\ 0.183 \end{pmatrix}$$

And then assemble them into a rotation matrix R so that $\det R = +1$.

$$R = \begin{pmatrix} 0.983 & -0.183 \\ 0.183 & 0.983 \end{pmatrix} \quad \det R = (0.983)(0.983) - (0.183)(-0.183) = 1$$

The rotation matrix has the form

$$R = \begin{pmatrix} \cos \theta & -\sin \theta \\ \sin \theta & \cos \theta \end{pmatrix} \quad D' = R^T M R$$

So $\theta = 10.5^\circ$, as we found earlier for one of the principal angles.

Using the rotation angle of 10.5° , the matrix M (representing the original stress state of the element) can be transformed to matrix D' (representing the principal stress state).

$$D' = R^T M R$$

$$D' = \begin{pmatrix} 0.983 & 0.183 \\ -0.183 & 0.983 \end{pmatrix} \begin{pmatrix} -80 & -25 \\ -25 & 50 \end{pmatrix} \begin{pmatrix} 0.983 & -0.183 \\ 0.183 & 0.983 \end{pmatrix}$$

$$D' = \begin{pmatrix} -84.6 & 0 \\ 0 & 54.6 \end{pmatrix}$$

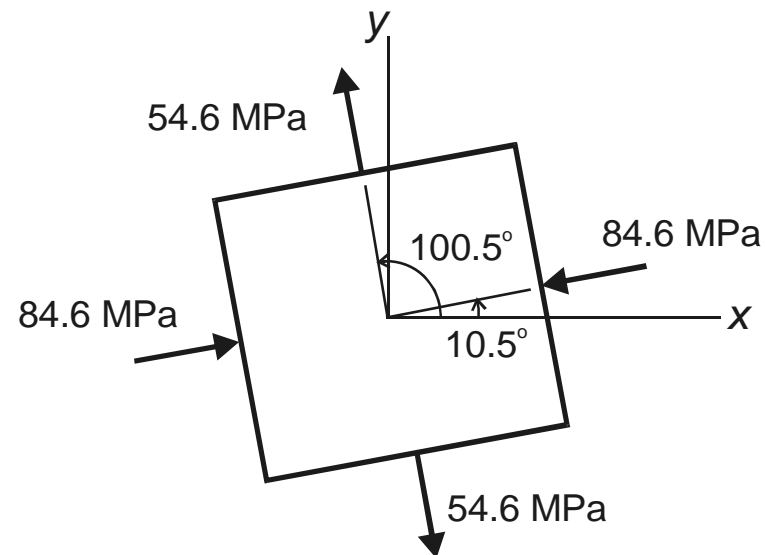

So, the transformation equations, Mohr's circle, and eigenvectors all give the same result for the principal stress element.

Finally, we can use the rotation matrix approach to find the stresses on an inclined element with $\theta = -30^\circ$.

$$R = \begin{pmatrix} \cos(-30^\circ) & -\sin(-30^\circ) \\ \sin(-30^\circ) & \cos(-30^\circ) \end{pmatrix} = \begin{pmatrix} 0.866 & 0.5 \\ 0.5 & 0.866 \end{pmatrix}$$

$$M' = R^T M R$$

$$M' = \begin{pmatrix} 0.866 & -0.5 \\ 0.5 & 0.866 \end{pmatrix} \begin{pmatrix} -80 & -25 \\ -25 & 50 \end{pmatrix} \begin{pmatrix} 0.866 & 0.5 \\ -0.5 & 0.866 \end{pmatrix}$$

$$M' = \begin{pmatrix} -25.8 & -68.8 \\ -68.8 & -4.15 \end{pmatrix} = \begin{pmatrix} \sigma_{x1} & \tau_{xy} \\ \tau_{yx} & \sigma_{y1} \end{pmatrix}$$

Again, the transformation equations, Mohr's circle, and the stress tensor approach all give the same result.

