

# 3

## PLASTIC ANALYSIS

---

E:\\_pedro\711\New ENCE - 711\chp\_3\TEXT\_3\_1.WPD  
Template: PLN TPL Sect 1\_a.wpd

### 3.1 COMPARISON OF ELASTIC AND PLASTIC ANALYSES

#### CONDITIONS FOR CORRECT PLASTIC ANALYSIS

1. **Mechanism:** The limit load is reached when the correct mechanism forms.
2. **Equilibrium:** The sum of all forces and moments is equal to zero.
3. **Plastic moment:** The moment may nowhere exceed  $M_p$ .

#### CONDITIONS FOR CORRECT ELASTIC ANALYSIS

1. **Continuity:** The deformations are proportional to the loads.
2. **Equilibrium:** The sum of all forces and moments is equal to zero.
3. **Yield moment:** The moment may nowhere exceed  $M_y$ .

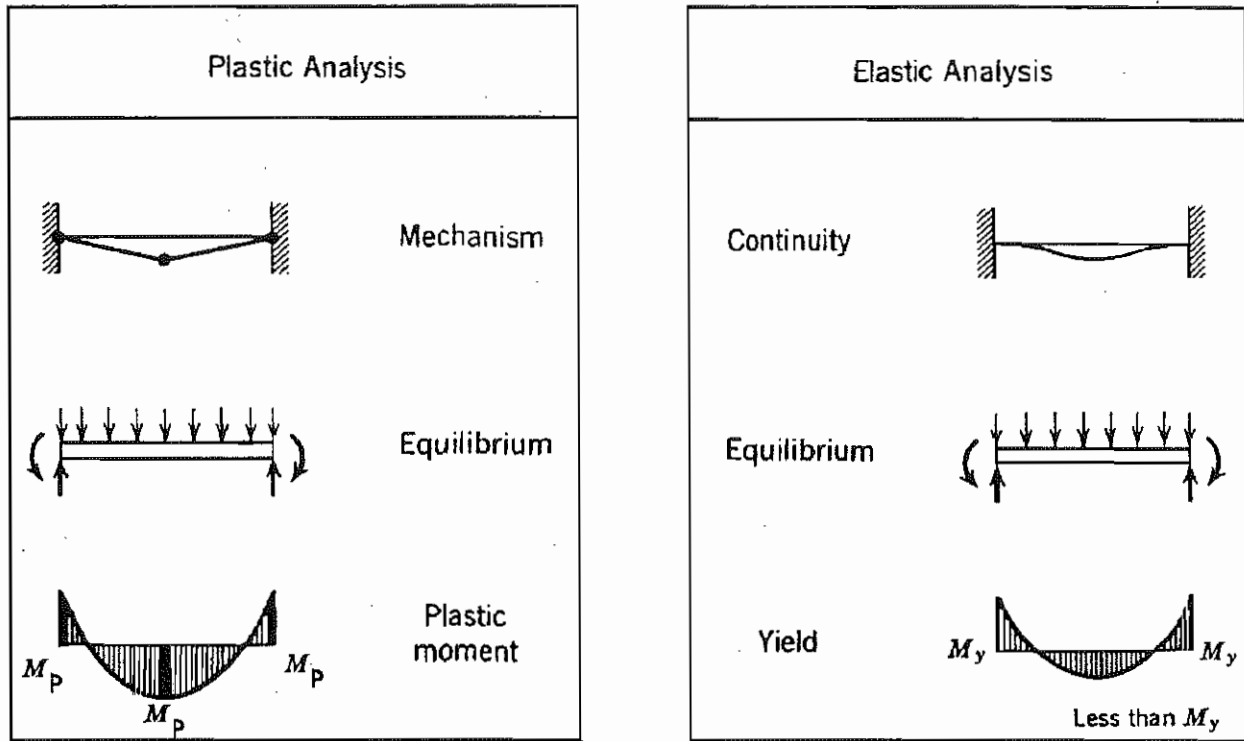

Fig. 3.1.1 Necessary Conditions for Correct Plastic and Elastic Analyses (Beedle 1958, p. 56)

E:\\_pedro\711\New ENCE - 711\chp\_3\TEXT\_3\_2.WPD  
Template: PLN TPL Sect 2\_a.wpd

## 3.2 FUNDAMENTAL PRINCIPLES

### 3.2.1 VIRTUAL WORK

If a system of forces in equilibrium is subjected to a virtual displacement, the work done by the external forces and internal moments vanishes.

$$W_E + W_I = 0$$

The internal work is negative as the plastic moments rotate in a direction opposite to the plastic hinges. For convenience of solving for the limit load, the equation is written in the form:

$$W_E = |W_I|$$

### 3.2.2 ASSUMPTIONS

- Material behavior:** The material is elastic-perfectly plastic.
- Small deformations:** The equilibrium equations can be written for the undeformed structure.
- No instability:** The structure reaches the limit load without becoming unstable.
- Continuity:** The connections can transmit the plastic moment,  $M_p$ .
- Axial and shear forces:** Their effects on  $M_p$  are neglected.
- Proportional loading:** All loads applied on a structure are in fixed proportions to each other.

### 3.2.3 LOWER BOUND

#### Theorem

"If any stress distribution throughout the structure can be found which is everywhere in equilibrium internally and balances certain external loads and at the same time does not violate the yield condition, those loads will be carried safely by the structure." (Calladine 1985, p. 96)

"An external load in equilibrium with a distribution of bending moment which nowhere exceeds the fully plastic value is less than or equal to the collapse load. Such a distribution of bending moment is referred to as statically admissible." (Chakrabarty 1987, p. 229)

#### Proof

The lower bound theorem can be proved in a manner similar to the proof of the upper bound theorem.

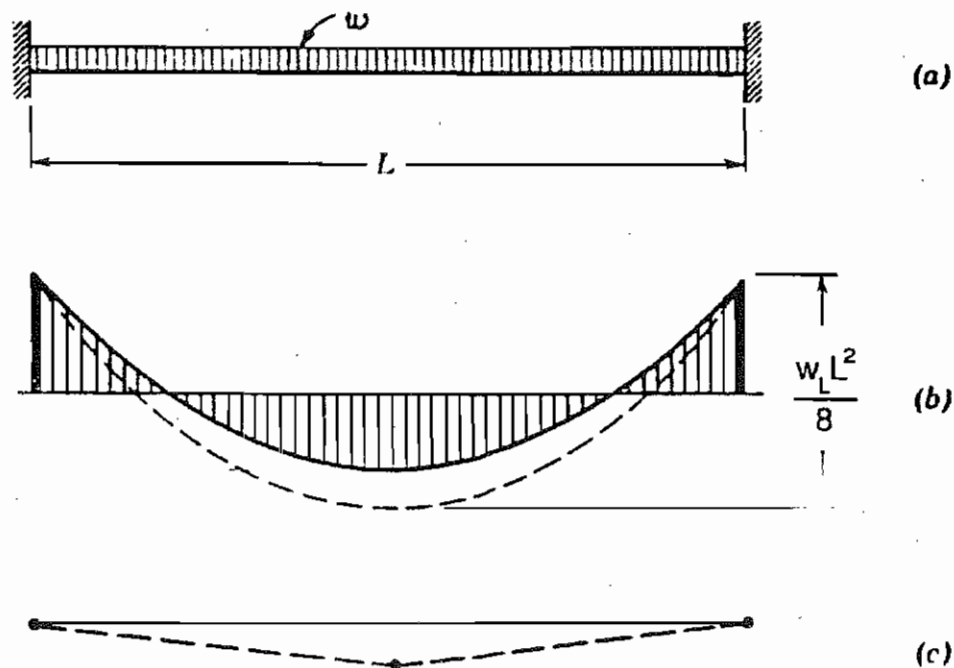

Fig. 3.2.1 Illustration of Lower Bound Theorem (Beedle 1958, p. 50)

### 3.2.4 UPPER BOUND

#### Theorem

"If an estimate of the plastic collapse load of a body is made by equating internal rate of dissipation of energy to the rate at which external forces do work in any postulated mechanism of deformation of the body, the estimate will be either higher, or correct." (Calladine 1985, p. 104)

"The load obtained by the external work done by it to the internal work absorbed at the plastic hinges in any assumed collapse mechanism is greater than or equal to the collapse load. The deformation mode represented by a collapse mechanism is said to be kinematically admissible." (Chakrabarty 1987, p. 229)

#### Proof

The limit load for the *correct* collapse mechanism of the given structure, designated by the subscript 1, is determined by equating the external work to the internal dissipation of energy:

$$\sum_i P_{1,i} u_{1,i} = \sum_j M_{1,j} \theta_{1,j}$$

where

$P_{1,i}$  = set of external forces applied at locations  $i$

$u_{1,i}$  = mechanism displacements in directions of external forces at locations  $i$

$M_{1,j}$  = set of internal moments at plastic hinge locations  $j$

$\theta_{1,j}$  = mechanism rotations in directions of internal moments at plastic hinge locations  $j$

Similarly, the limit load for *any other* geometrically possible mechanism, designated by the **subscript 2**, is determined from:

$$\sum_i P_{2,i} u_{2,i} = \sum_k M_{2,k} \theta_{2,k} \quad (\text{Eq. 3.2.4})$$

where

$P_{2,i}$  = set of external forces applied at locations  $i$

$u_{2,i}$  = mechanism displacements in directions of external forces at locations  $i$

$M_{2,k}$  = set of internal moments at plastic hinge locations  $k$

$\theta_{2,k}$  = mechanism rotations in directions of internal moments at plastic hinge locations  $k$

Now, let the set of equilibrium forces  $P_{1,i}$  and internal moments  $M_{1,j}$  from the correct mechanism 1 undergo the displacements  $u_{2,i}$  and rotations  $\theta_{2,k}$  from any other mechanism:

$$\sum_i P_{1,i} u_{2,i} = \sum M_{1,j} \theta_{2,k} \quad (\text{Eq. 3.2.5})$$

Subtracting Eq. 3.2.5 from Eq. 3.2.4 gives

$$\sum_i (P_{2,i} - P_{1,i}) u_{2,i} = \sum (M_{2,k} - M_{1,j}) \theta_{2,k} \quad (\text{Eq. 3.2.6})$$

At the plastic hinges of the second mechanism, the moments are  $M_{2,k} = M_p$ .

Since the first mechanism may not have hinges at the same locations as those of the second mechanism, the moments of the first mechanism at the locations of the plastic hinges of the second mechanism are  $M_{1,j} \geq M_p$ . Therefore, the right side of Eq. 3.2.6 is always greater than or equal to zero. Accordingly, the left side must also be greater than or equal to zero, meaning that

$$P_{2,i} \geq P_{1,i}$$

Or, in other words, the correct mechanism is the one that gives the lowest all limit load values.

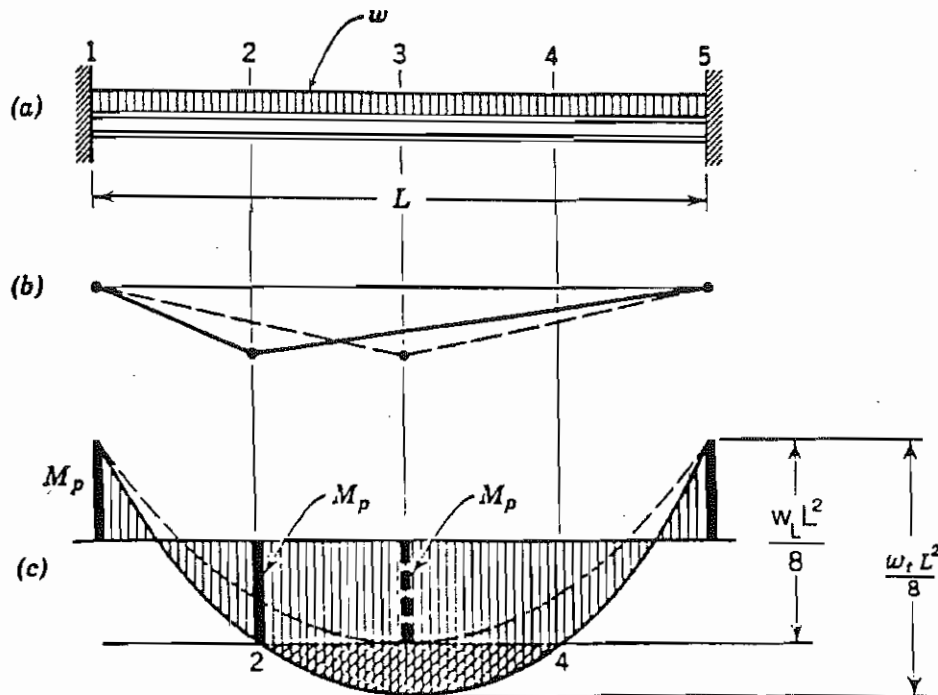

Fig. 3.2.2 Illustration of Upper Bound Theorem (Beedle 1958, p. 59)

### 3.2.5 COROLLARIES OF THE BOUND THEOREMS

"The two limit theorems can be combined to form a *uniqueness theorem* which states that if any statically admissible distribution of bending moment can be found in a structure that has sufficient number of yield hinges to produce a mechanism, the corresponding load is equal to the collapse load." (Chakrabarty 1987, p. 229)

"If in a body we are in position to investigate all possible distributions of stress which are in equilibrium and do not violate the yield condition, the highest lower-bound load discovered must be equal to the collapse load." (Calladine 1985, p. 110)

"Addition of material to a (weightless) structure without any change in the position of the applied loads cannot result in a lower collapse load. The removal of material cannot strengthen it." (Calladine 1985, p. 110)

“Increasing (decreasing) the yield strength of the material cannot weaken (strengthen) it.” (Calladine 1985, p. 111)

The bound theorems are valid only if the material is elastic-perfectly plastic. In a possible parallel idea in elasticity theory, it would be false to say that “addition of material will always decrease stress concentration.”

### 3.2.6 SUMMARY

If the correct mechanism is selected, the moment does not exceed  $M_p$  anywhere, the solution is exact, and the conditions of plastic analysis are satisfied. If an incorrect mechanism is assumed, the moment exceeds  $M_p$  somewhere, the solution is an upper bound, and the plastic moment condition is not satisfied.

#### Example

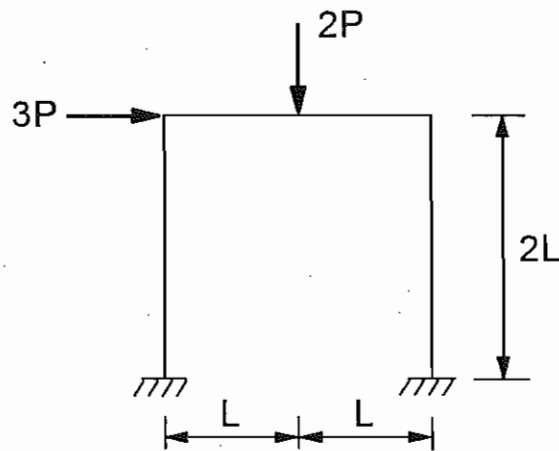

For this structure and loading, the panel mechanism gives the correct limit load:

$$P_{L,1} = \frac{2}{3} \cdot \frac{M_p}{L}$$



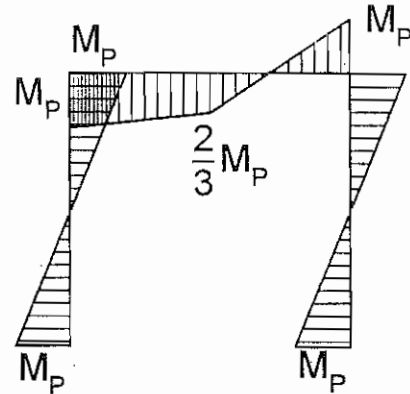
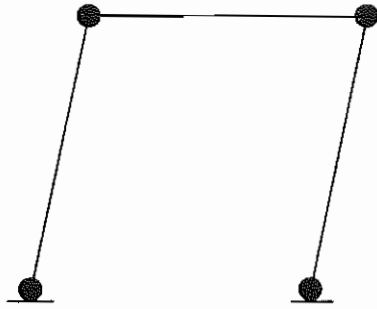

The combined mechanism gives a limit load greater than the correct limit load from the panel mechanism and, as a result, the moment at the left beam-to-column connection exceeds the plastic moment:

$$P_{L,2} = \frac{3}{2} \cdot \frac{M_p}{L}$$

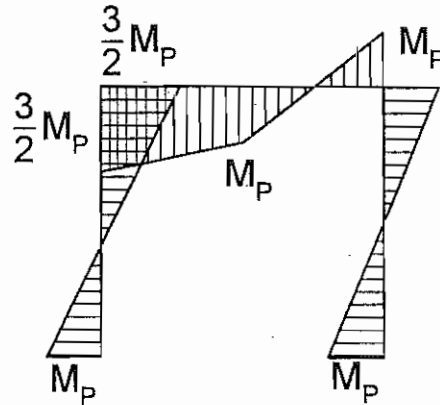
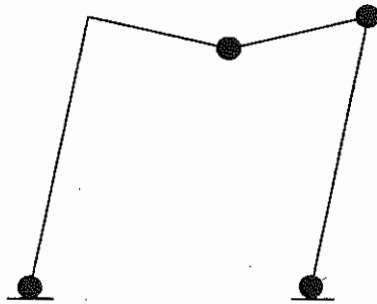

Dividing the moment diagram by 3/2 would satisfy the plastic moment condition but violate the mechanism condition.

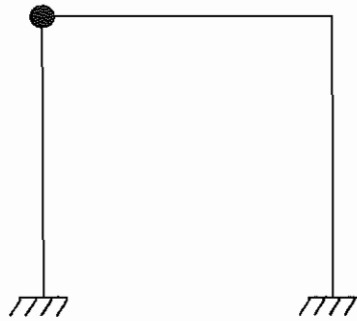

(No mechanism)

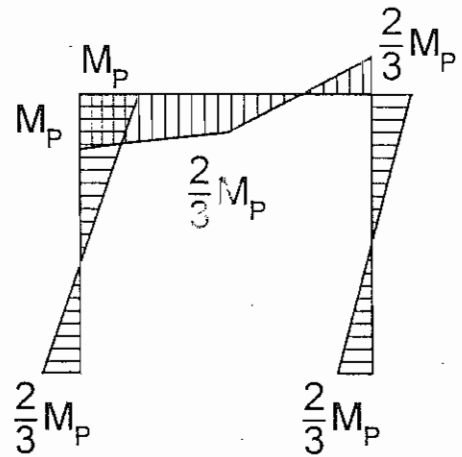

Since a mechanism has not formed, the limit load corresponding to the reduced bending moment diagram becomes a lower bound:

$$P_{L,3} = \frac{P_{L,2}}{3/2} = \frac{1}{2} \cdot \frac{M_P}{L} < P_{L,1}$$

E:\\_pedro\711\New ENCE - 711\chp\_3\TEXT\_3\_3.WPD  
Template: PLN TPL Sect 2\_a.wpd

## 3.3 STATICAL METHOD OF ANALYSIS

### 3.3.1 APPROACH

The objective is to find an equilibrium moment diagram in which  $M \leq M_p$  such that a mechanism is formed. The procedure is as follows:

- Select sufficient redundancies to make the structure is statically determinant.
- Draw the moment diagrams due to the redundant reactions and moments.
- Draw the moment diagram due to the applied loads.
- Draw the composite moment diagram in such a way that a mechanism is formed.
- Compute the limit load from an equilibrium equation.
- Verify that the plastic moment condition is satisfied,  $M \leq M_p$ .

3.3.2 EXAMPLE 1: TWO-SPAN CONTINUOUS BEAM

Structure:

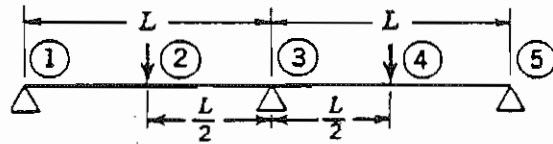

Redundants:



Moment diagram due to redundant moment:



Applied loads:

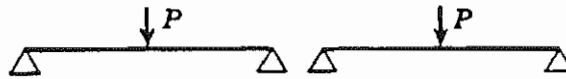

Moment diagram due to applied loads:

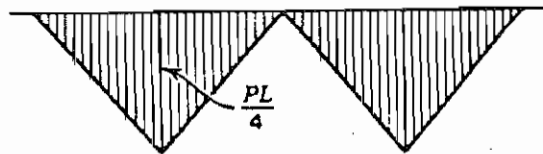

Composite moment diagram:

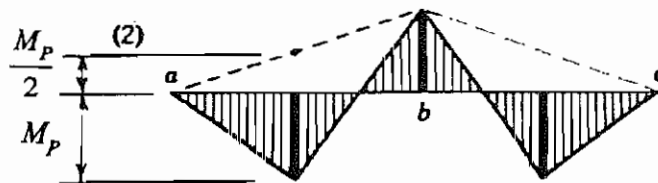

From moment equilibrium:

$$\frac{PL}{4} = M_p + \frac{M_p}{2} \quad ; \quad P_L = \frac{6M_p}{L}$$

Mechanism:

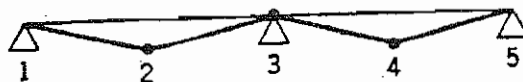
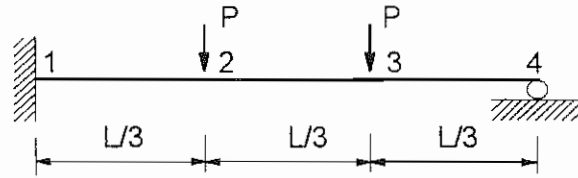

Fig. 3.3.1 Plastic Analysis of Two-Span Continuous Beam, Statical Method (Beedle 1958, p. 64)

3.3.3 EXAMPLE 2: BEAM FIXED AT ONE END, SUPPORTED AT OTHER

Structure:



Redundants:

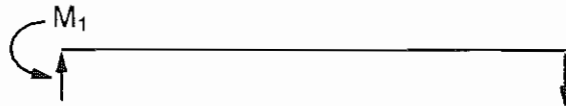

Moment diagram due to redundant moment:

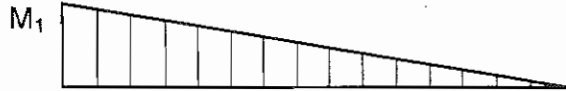

Applied loads:



Moment diagram due to applied loads:

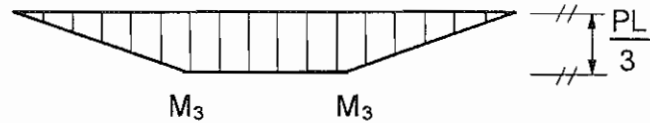

Composite moment diagram:

- Hinges form at 1 and 3:

$$\frac{P_L L}{3} = \frac{M_P}{3} + M_P = \frac{4}{3} M_P$$

$$P_L = \frac{4 M_P}{L}$$

- Hinges form at 1 and 2: violates plastic moment,  $M_3 > M_P$

- Hinges form at 2 and 3: violates equilibrium condition.

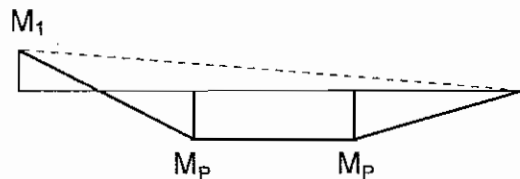
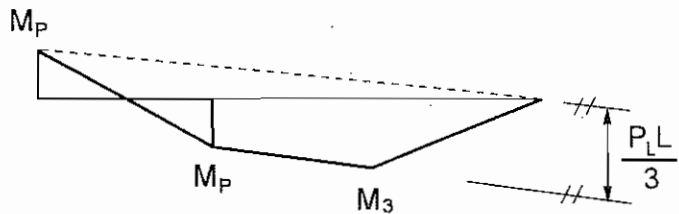
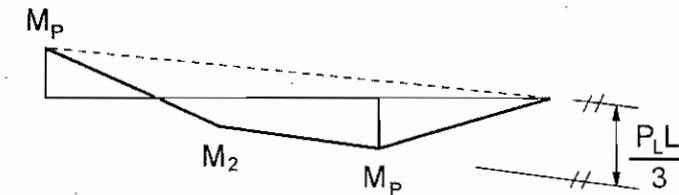

Mechanism:

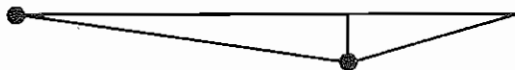

## 3.4 MECHANISM METHOD OF ANALYSIS

### 3.4.1 APPROACH

Find a mechanism (independent or composite) as follows:

1. Determine all locations where plastic hinges could form (load points, connections, points of zero shear in a prismatic beam loaded uniformly).
2. Determine all independent and composite mechanisms.
3. Calculate the limit load for each mechanism with the virtual work method.
4. Select the mechanism that gives the lowest limit load and verify that the plastic moment condition is satisfied at all sections,  $M \leq M_p$ .

Suppose there are  $N$  critical sections at which plastic hinges may form under a given loading system, and let  $x$  denote the number of redundants. Since the bending moments at the critical sections would be completely determined if the values of these redundants were known, there must be  $N - x$  independent relations connecting the  $N$  critical moments. Each of these relations is an equation of statical equilibrium that can be associated with a possible independent mechanisms through the virtual work principle. It follows, therefore, that the number of possible independent mechanisms, from which all other mechanisms of collapse can be deduced is

$$n = N - x$$

where

- $n$  = number of possible independent mechanisms
- $N$  = number of possible plastic hinges
- $x$  = number of redundants

Total number of independent and combined mechanisms:

$$N_{\text{mech}} = \sum_{k=1}^n \frac{n!}{k!(n-k)!} = \frac{n}{1} + \frac{n(n-1)}{1 \cdot 2} + \frac{n(n-1)(n-2)}{1 \cdot 2 \cdot 3} + \dots = 2^n - 1$$

where

- $n$  = number of independent mechanisms

$k$  = counter

### 3.4.2 TYPES OF MECHANISMS

For convenience in referring to different modes of failure, the various types of mechanisms are illustrated in FIG. 3.4.1, using the structure shown in sketch (a):

#### **Beam mechanism** Sketch (b)

Four examples are given here of the displacement of single spans under load.

#### **Panel mechanism** Sketch (c)

This motion is due to side-sway.

#### **Gable mechanism** Sketch (d)

This is a characteristic mechanism of gabled frames, involving spreading of the column tops with respect to the bases.

#### **Joint mechanism** Sketch (e)

This independent mechanism forms at the junction of three or more members and represents motion under the action of an applied moment.

#### **Composite mechanism** Sketches (f), (g)

Independent mechanisms may be combined in different ways. A composite mechanism may be "partial" as indicated by sketch (f) and for which the frame is still indeterminate at failure; or it may be a "complete" composite mechanism, in which case the frame is determinate at failure.

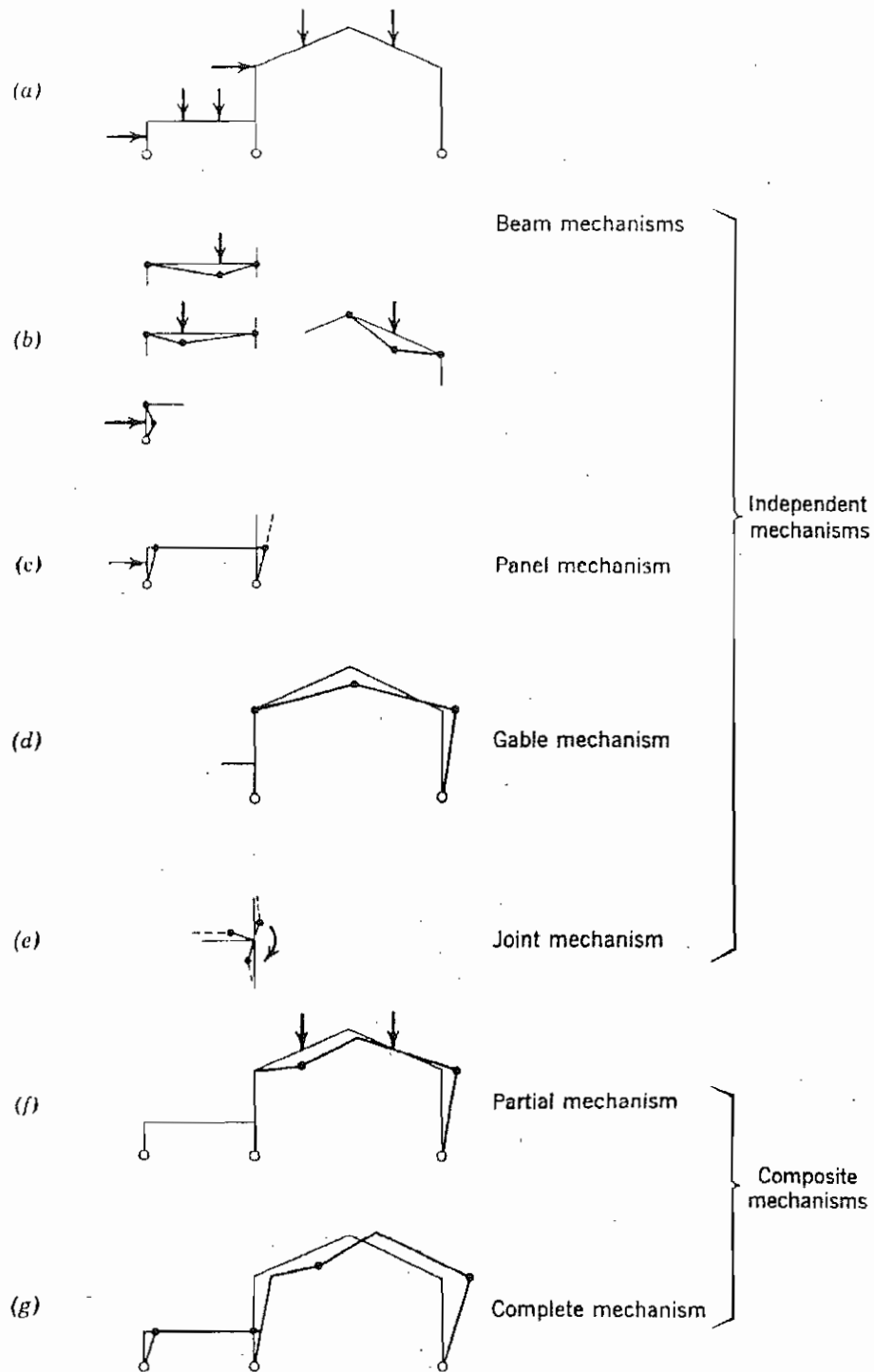

FIG. 3.4.1. Types of Mechanism (Beedle 1958, p. 73)



3.4.3 EXAMPLE 1: TWO-SPAN CONTINUOUS BEAM

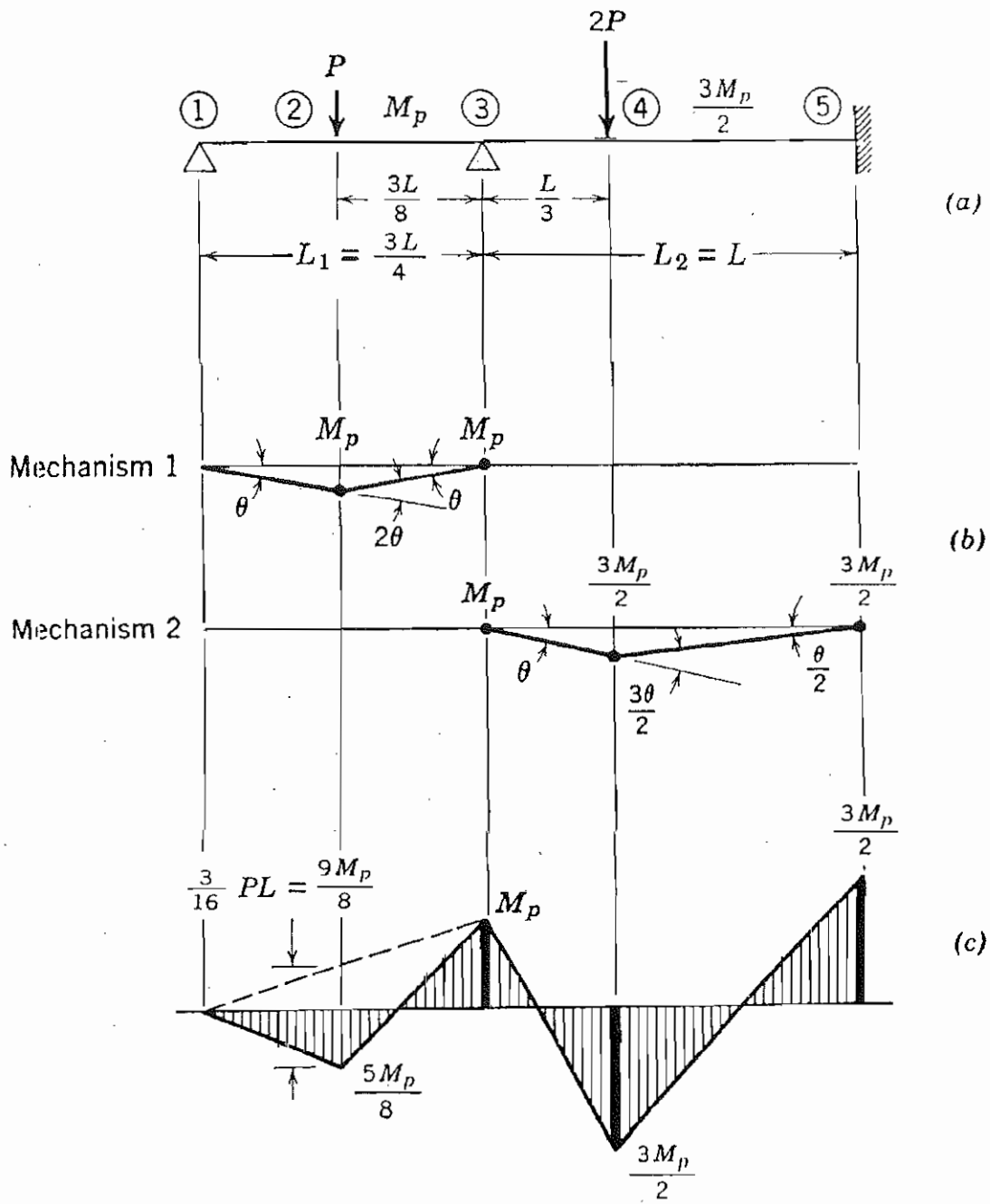

FIG. 3.4.2. Unsymmetrical Two-Span Continuous Beam (Beedle 1958, p. 67)

### Number of Independent Mechanisms

$$n = N - x = 4 - 2 = 2$$

### First Beam Mechanism

$$W_E = P \cdot \theta \frac{3L}{8} = \frac{3}{8} \theta L P$$

$$W_I = M_p (2\theta + \theta) = 3\theta M_p$$

From  $W_E = W_I$ :

$$P_L = \frac{8M_p}{L}$$

### Second Beam Mechanism

$$W_E = 2P \cdot \theta \frac{L}{3} = \frac{2}{3} \theta L P$$

$$W_I = M_p \theta + \frac{3M_p}{2} \frac{3\theta}{2} + \frac{3M_p}{2} \frac{\theta}{2} = 4\theta M_p$$

From  $W_E = W_I$ :

$$P_L = \frac{6M_p}{L} \quad \leftarrow \text{Controls}$$

### Combined Mechanism

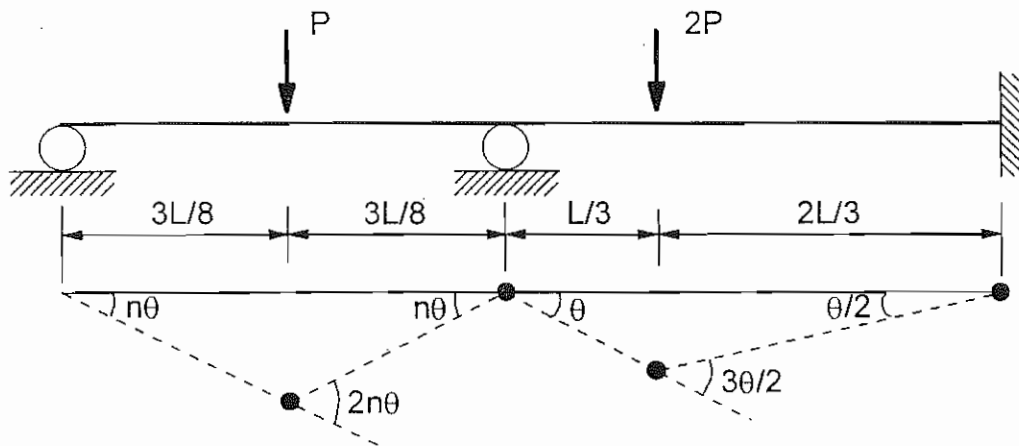

The virtual rotations  $n\theta$  and  $\theta$  are arbitrary. One is not a function of the other.

$$P \cdot n\theta \frac{3L}{8} = M_p (2n\theta + n\theta)$$

$$2P \cdot \theta \frac{L}{3} = M_p \theta + \frac{3M_p}{2} \left( \frac{3\theta}{2} + \frac{\theta}{2} \right)$$

Add the above equations:

$$LP \left( \frac{3}{8}n + \frac{2}{3} \right) = M_p (3n + 4)$$

and solve for the limit load:

$$P_L = \frac{24(3n + 4)}{9n + 16} \frac{M_p}{L}$$

For  $n = \infty$ :  $P_L = 8 \frac{M_p}{L} \rightarrow$  First beam mechanism

For  $n = 0$ :  $P_L = 6 \frac{M_p}{L} \rightarrow$  Second beam mechanism

Combinations of the two mechanisms yield limit loads of  $6M_p/L < PL < 8M_p/L$  for  $0 < n < \infty$ , but in this case the combined mechanism is not physically possible.

3.4.4 EXAMPLE 2: SYMMETRIC PORTAL FRAME

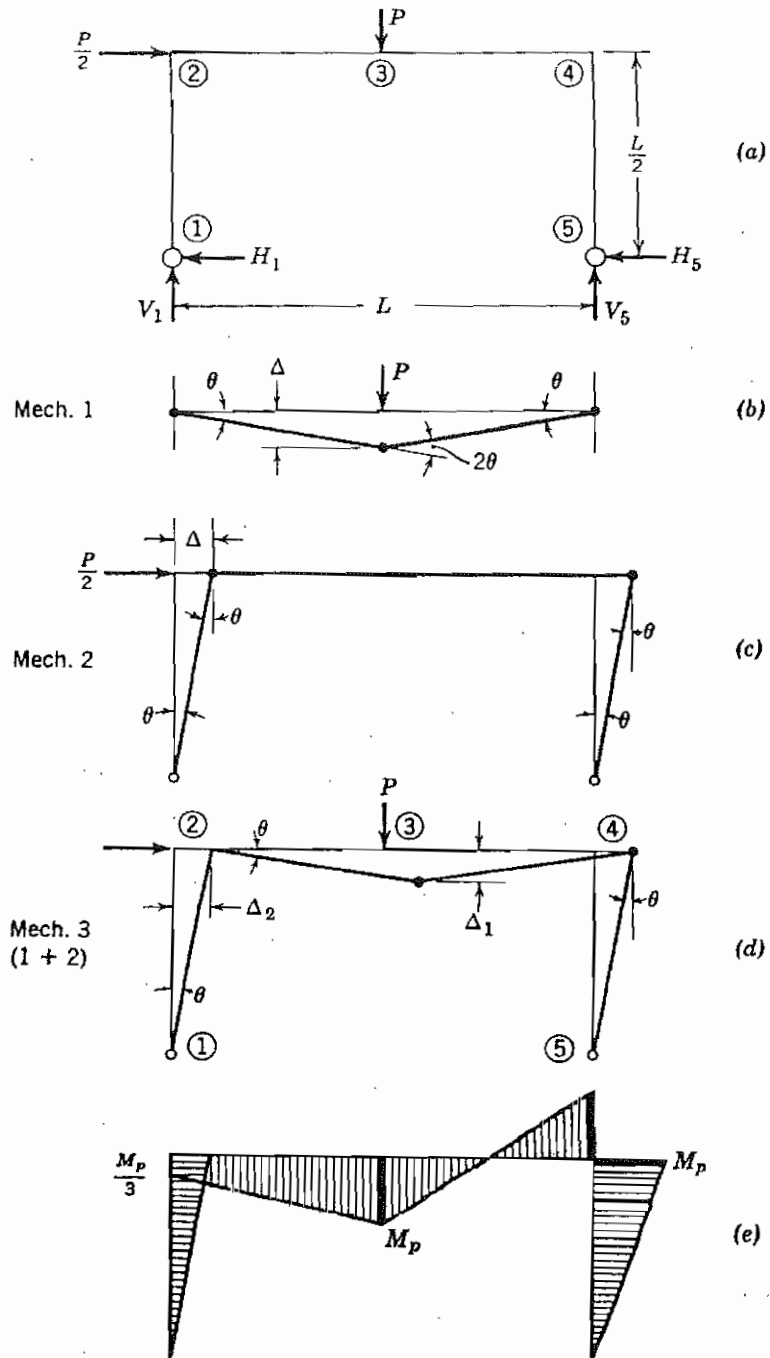

FIG. 3.4.3. Symmetric Rectangular Portal Frame with Pinned Bases (Beedle 1958, p. 71)

Number of Independent Mechanisms

$$n = N - x = 3 - 1 = 2$$

### Beam Mechanism

$$P \cdot \theta \frac{L}{2} = M_p (\theta + 2\theta + \theta)$$

$$P_L = \frac{8M_p}{L}$$

### Panel Mechanism

$$\frac{P}{2} \cdot \theta \frac{L}{2} = M_p (\theta + \theta)$$

$$P_L = \frac{8M_p}{L}$$

### Combined Mechanism

$$P \cdot \theta \frac{L}{2} + \frac{P}{2} \cdot \theta \frac{L}{2} = M_p (2\theta + 2\theta)$$

$$P_L = \frac{16M_p}{3L} \quad \leftarrow \text{Controls}$$

### Reactions for Combined Mechanism

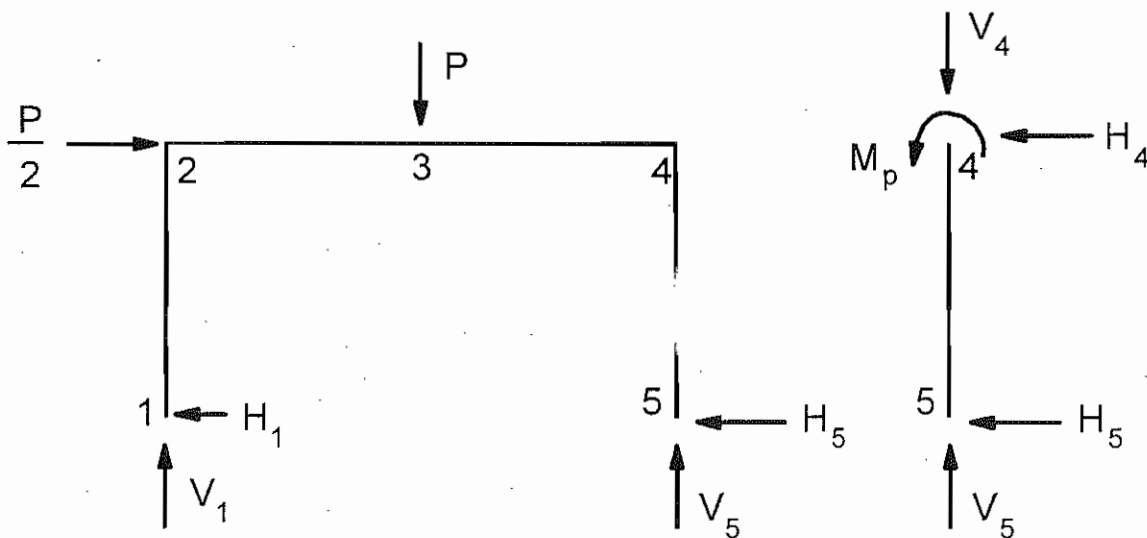

From free-body diagram of right column:

$$\sum M_4 = 0: \quad -H_5 \frac{L}{2} + M_p = 0$$

$$H_5 = \frac{2M_p}{L}$$

From free-body diagram of portal frame:

$$\sum F_x = 0: \quad \frac{P}{2} - H_1 - H_5 = \frac{1}{2} \frac{16M_p}{3L} - H_1 - \frac{2M_p}{L} = 0$$

$$H_1 = \frac{2M_p}{3L}$$

$$\sum M_1 = 0: \quad V_5 L - P \frac{L}{2} - \frac{P}{2} \frac{L}{2} = V_5 L - \frac{16M_p}{3L} \frac{L}{2} - \frac{16M_p}{3L} \frac{L}{4} = 0$$

$$V_5 = \frac{4M_p}{L}$$

$$\sum F_y = 0: \quad V_1 + V_5 - P = V_1 + \frac{4M_p}{L} - \frac{16M_p}{3L} = 0$$

$$V_1 = \frac{4M_p}{3L}$$

3.4.5 EXAMPLE 3: NONSYMMETRIC PORTAL FRAME

$L = 20 \text{ m}$ ,  $M_{p1} = 30 \text{ kN}\cdot\text{m}$ ,  $M_{p2} = 55 \text{ kN}\cdot\text{m}$ ,  $M_{p3} = 20 \text{ kN}\cdot\text{m}$

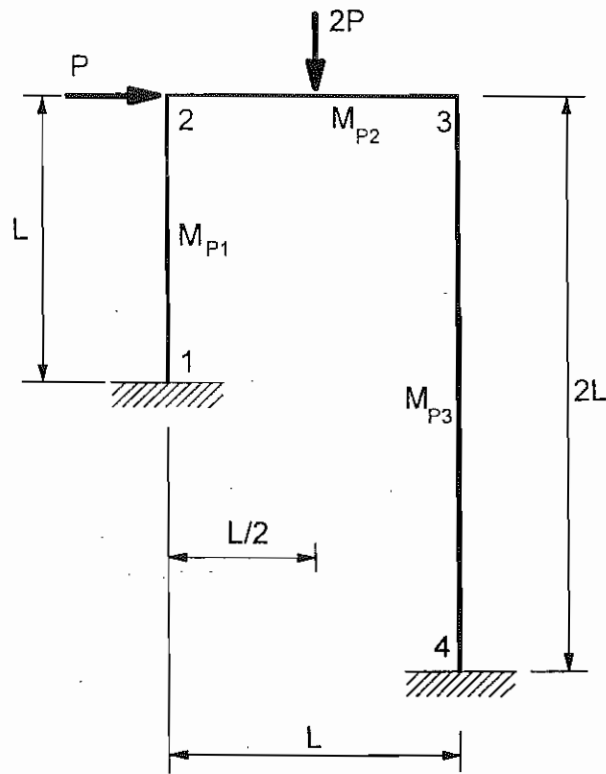

Number of Independent Mechanisms

$$n = N - x = 5 - 3 = 2$$

Beam Mechanism

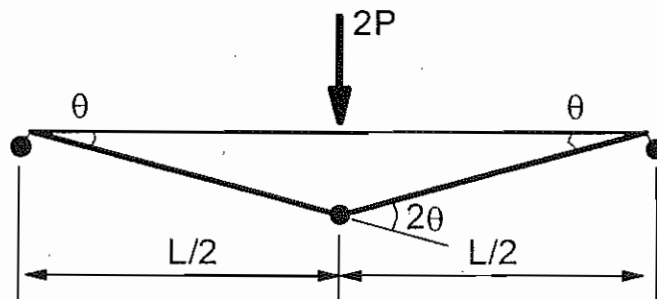

$$2P \cdot \frac{\theta L}{2} = M_{p1} \theta + M_{p2} \cdot 2\theta + M_{p3} \theta$$

$$20P = 30 + 2 \cdot 55 + 20$$

$$P_L = 8.0 \text{ kN}$$

### Panel Mechanism

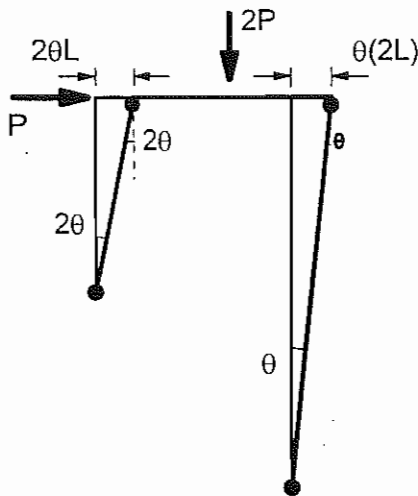

$$P \cdot 2\theta L = M_{p1} \cdot (2\theta + 2\theta) + M_{p3} \cdot (\theta + \theta)$$

$$40P = 30 \cdot 4 + 20 \cdot 2$$

$$P_L = 4.0 \text{ kN} \quad \leftarrow \text{Controls}$$

### Combined Mechanism

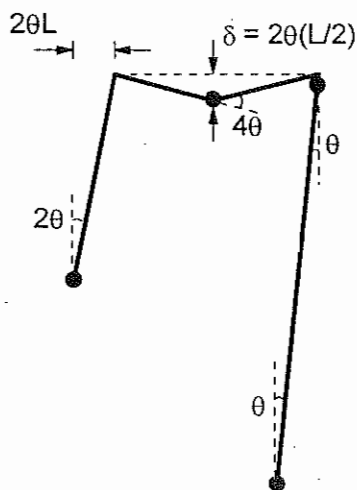

$$P \cdot 2\theta L + 2P \cdot 2\theta \frac{L}{2} = M_{p1} \cdot 2\theta + M_{p2} \cdot 4\theta + M_{p3} (3\theta + \theta)$$

$$40P + 40P = 30 \cdot 2 + 55 \cdot 4 + 20 \cdot 4$$

$$P_L = 4.5 \text{ kN}$$



Reactions for  $P_L = 4.0$  kN

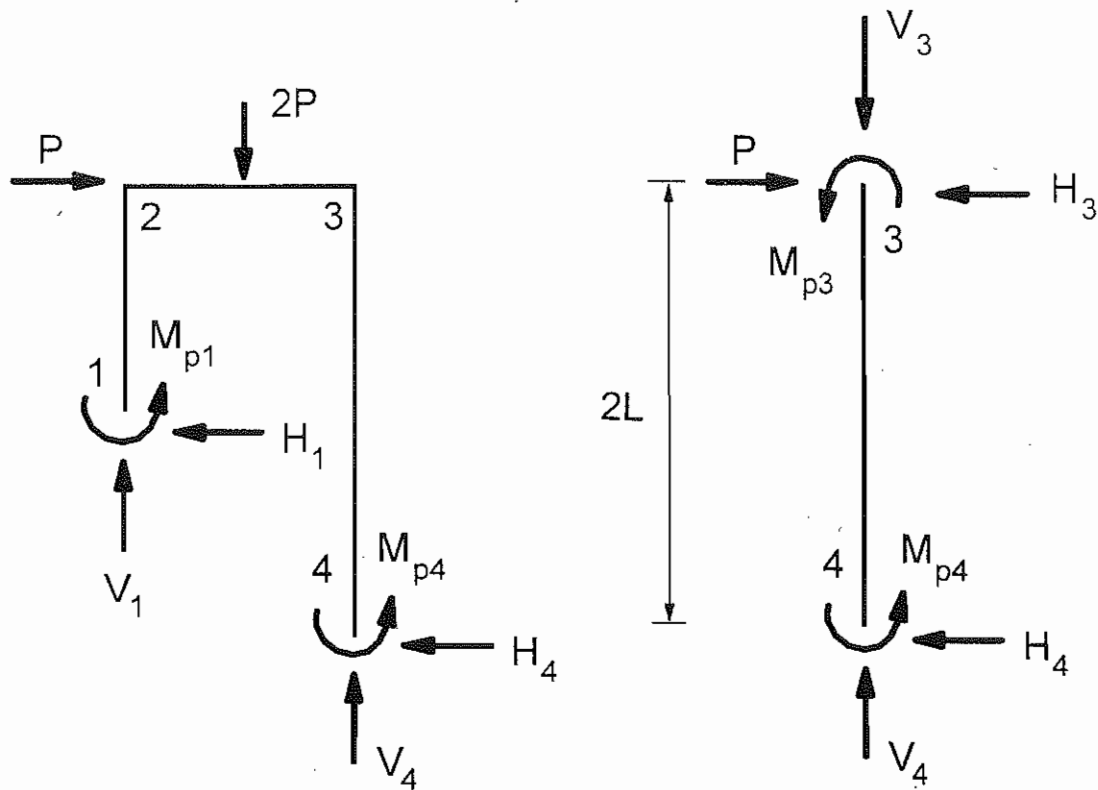

From free-body diagram of right column:

$$\sum M_3 = 0: \quad 2M_{p3} - H_4 \cdot 2L = 0 \cdot 20 - H_4 \cdot 40 = 0$$

$$H_4 = 1.0 \text{ kN}$$

From free-body diagram of portal frame:

$$\sum M_1 = 0: \quad V_4 \cdot L_1 + M_{p3} - H_4(L_2 - L_1) - 2P \cdot \frac{L_1}{2} - P \cdot L_1 + M_{p1} = 0$$

$$V_4 = 6.5 \text{ kN}$$

$$\sum F_y = 0: \quad V_1 + V_4 - 2P = 0$$

$$V_1 = 1.5 \text{ kN}$$

$$\sum F_x = 0: \quad -H_1 - H_4 + P = -H_1 - 1.0 + 4.5 = 0$$

$$H_1 = 3.0 \text{ kN}$$

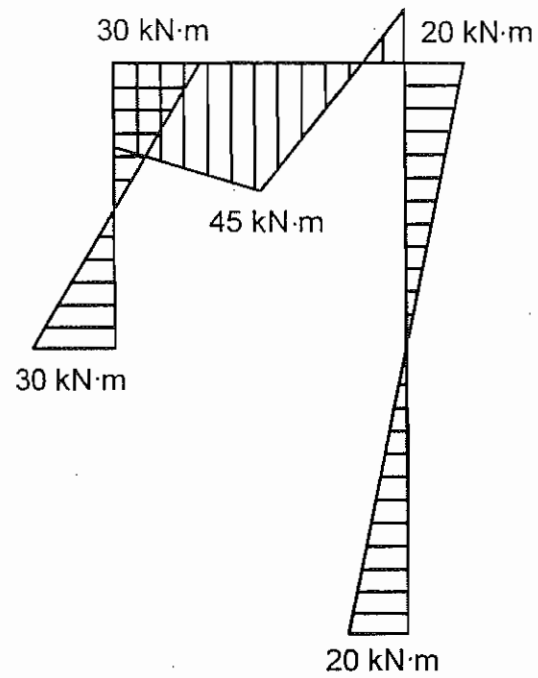
**Bending Moment Diagram for Limit Load,  $P_L = 4.0$  kN**

## 3.4.6 EXAMPLE 4: PORTAL FRAME — INSTANTANEOUS CENTER

## Displacement of a Point

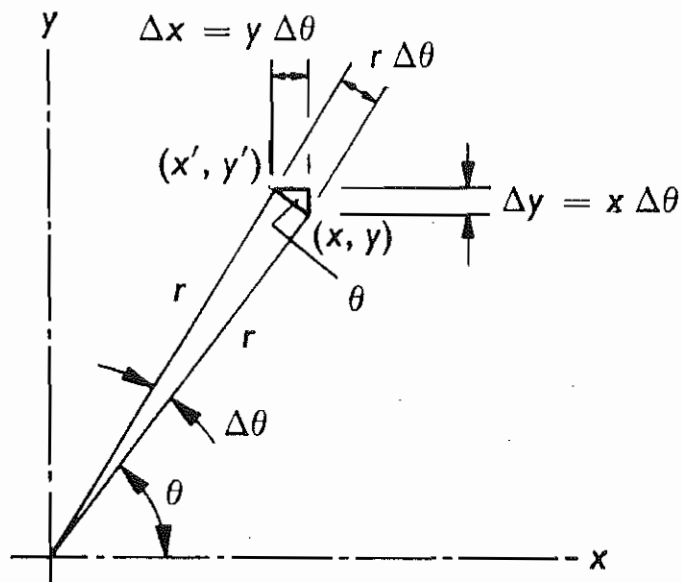

Let  $(x, y)$  be any point as shown in the figure above and let it be rotated about the origin through a small angle  $\theta$  to a new position  $(x', y')$ . The displacement of the point is  $r\theta$  and for small displacements it moves along a path perpendicular to the radius. The horizontal component of this displacement is  $r\theta \cdot (\sin \theta)$ . But  $\sin \theta = y/r$  so that the horizontal component of the displacement becomes (Shermer 1972, p. 291):

$$\Delta_h = y \Delta\theta$$

Similarly, the vertical component of the displacement is

$$\Delta_v = x \Delta\theta$$

## Combined Mechanism

Referring to example 2, calculate the limit load for the combined mechanism using the instantaneous center method.

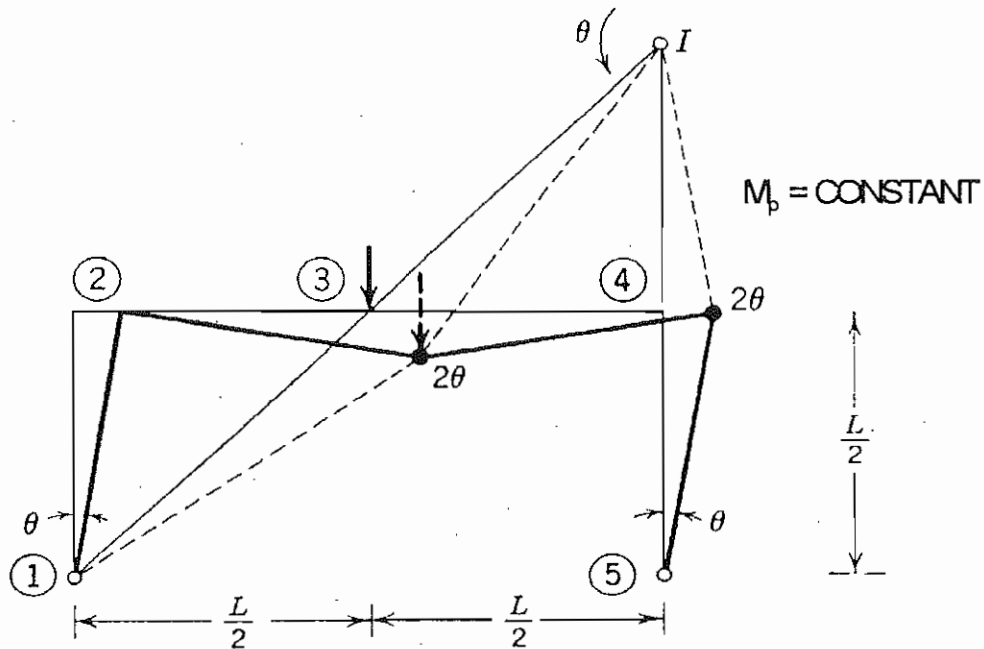

FIG. 3.4.7. Location of Instantaneous Center for Rectangular Frame Mechanism of FIG. 3.4.3. (Beedle 1958, p. 77)

Hinge rotations:

Assumed:  $\theta_5 = \theta$

$$\theta_{IC} = \frac{\theta \cdot \frac{L}{2}}{\frac{L}{2}} = \theta$$

$$\theta_4 = \theta_5 + \theta_{IC} = 2\theta$$

$$\theta_1 = \frac{\theta_{IC} \cdot \frac{L}{2} \sqrt{2}}{\frac{L}{2} \sqrt{2}} = \theta$$

$$\theta_3 = \theta_{IC} + \theta_1 = 2\theta$$

Load displacements:

$$\Delta_{2x} = \theta_1 \cdot \frac{L}{2} = \theta \frac{L}{2}$$

$$\Delta_{3y} = \theta_{IC} \cdot \frac{L}{2} = \theta \frac{L}{2}$$

Virtual work:

$$\frac{P}{2} \cdot \theta \frac{L}{2} + P \cdot \theta \frac{L}{2} = M_p (2\theta + 2\theta)$$

$$P_L = \frac{16}{3} \frac{M_p}{L}$$

## 3.4.7 EXAMPLE 5: GABLE FRAME — INSTANTANEOUS CENTER

Calculate the limit load for the combined mechanism using the instantaneous center method.

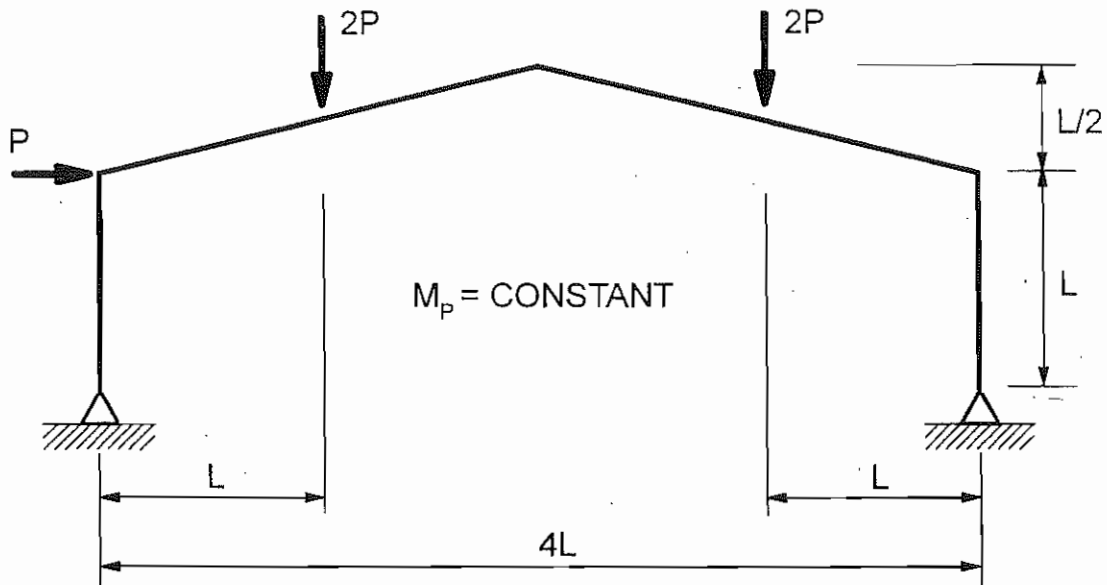

Rotations:

$$\theta_7 = \theta$$

$$\theta_{IC} = \frac{\theta \cdot L}{4L} = \frac{\theta}{4}$$

$$\theta_6 = \theta_7 + \theta_{IC} = \frac{5\theta}{4}$$

$$\theta_1 = \frac{\theta_{IC} \cdot 3L}{L} = \frac{3\theta}{4}$$

$$\theta_3 = \theta_{IC} + \theta_1 = \frac{3\theta}{4}$$

Load displacements:

$$\Delta_{2h} = \theta_1 \cdot L = \frac{3\theta L}{4}$$

$$\Delta_{3v} = \theta_{IC} \cdot 3L = \frac{3\theta L}{4}$$

$$\Delta_{5v} = \theta_{IC} \cdot L = \frac{\theta L}{4}$$

Virtual work:

$$P \frac{3\theta L}{4} + 2P \frac{3\theta L}{4} + 2P \frac{\theta L}{4} = M_p \left( \frac{3\theta}{4} + \frac{\theta}{4} \right) + M_p \left( \theta + \frac{\theta}{4} \right)$$

$$P_L = \frac{9}{11} \frac{M_p}{L}$$

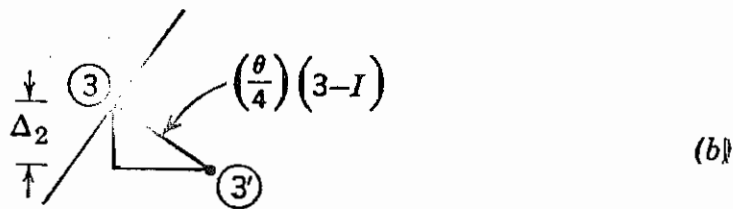
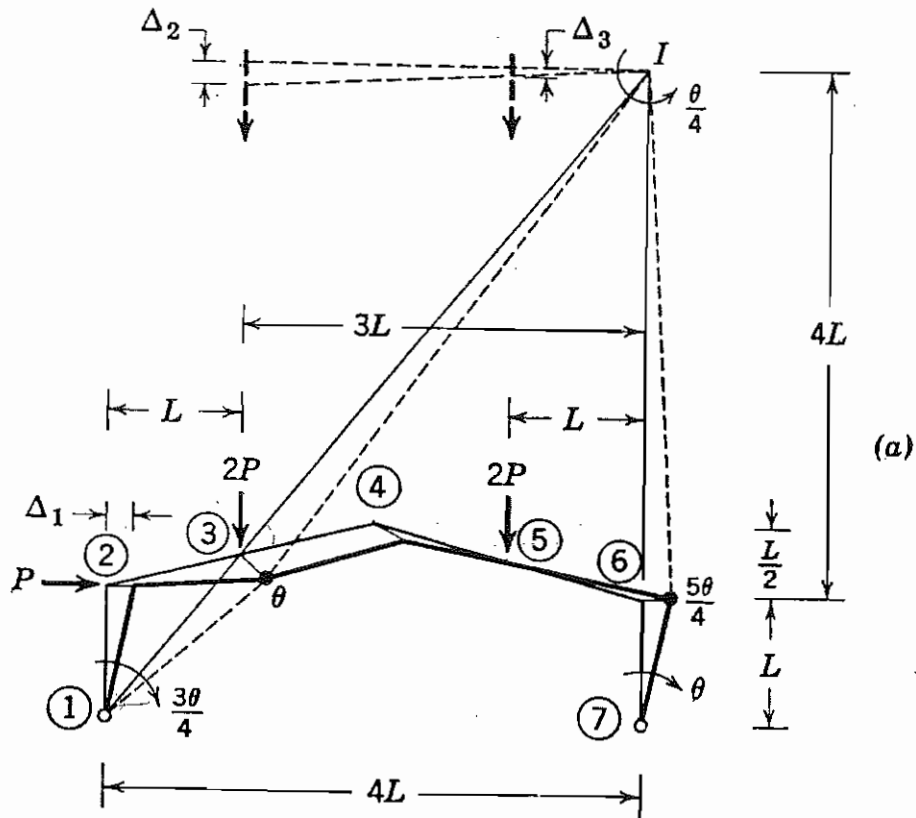

$$\frac{\Delta_2}{3} = \frac{3L}{(3-L)} \left[ \frac{\theta}{4} (3-L) \right] = 3L \frac{\theta}{4}$$

g. 3.12. Location of instantaneous center for a gabled frame mechanism

3.4.8 EXAMPLE 6: PORTAL FRAME — UNIFORMLY DISTRIBUTED LOAD

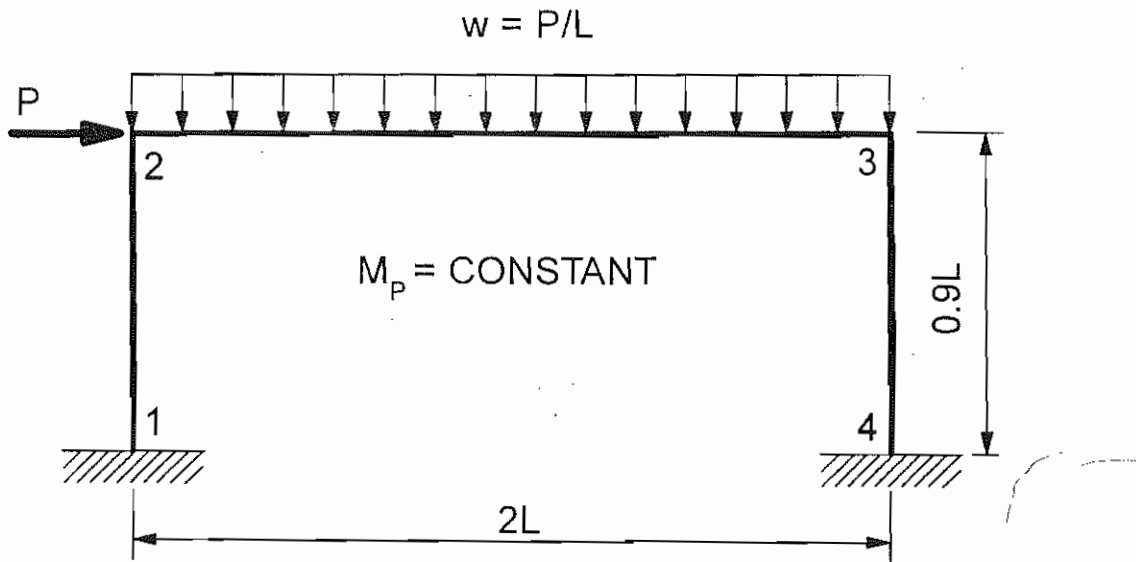

Number of Independent Mechanisms

$$n = N - x = 5 - 3 = 2$$

Beam Mechanism

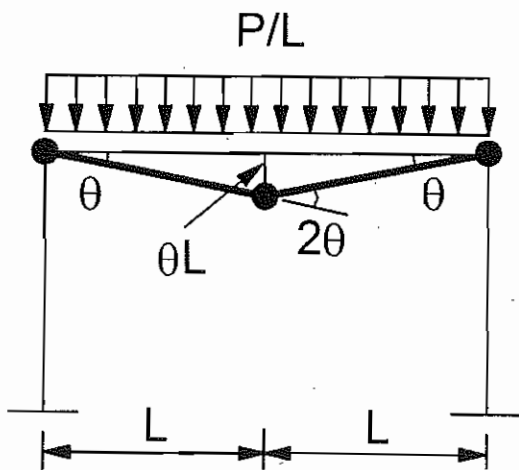

$$\frac{P}{L} \left( \frac{1}{2} 2L \cdot \theta L \right) = M_p (\theta + 2\theta + \theta)$$

$$P\theta L = 4\theta M_p$$

$$P_L = \frac{4M_p}{L}$$

Panel Mechanism

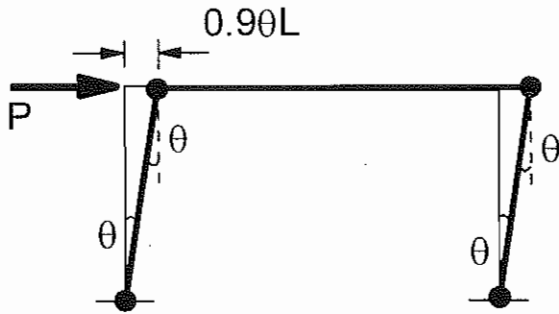

$$P \cdot 0.9L = M_p (\theta + \theta + \theta + \theta)$$

$$P_L = \frac{4.44 M_p}{L}$$

Combined Mechanism

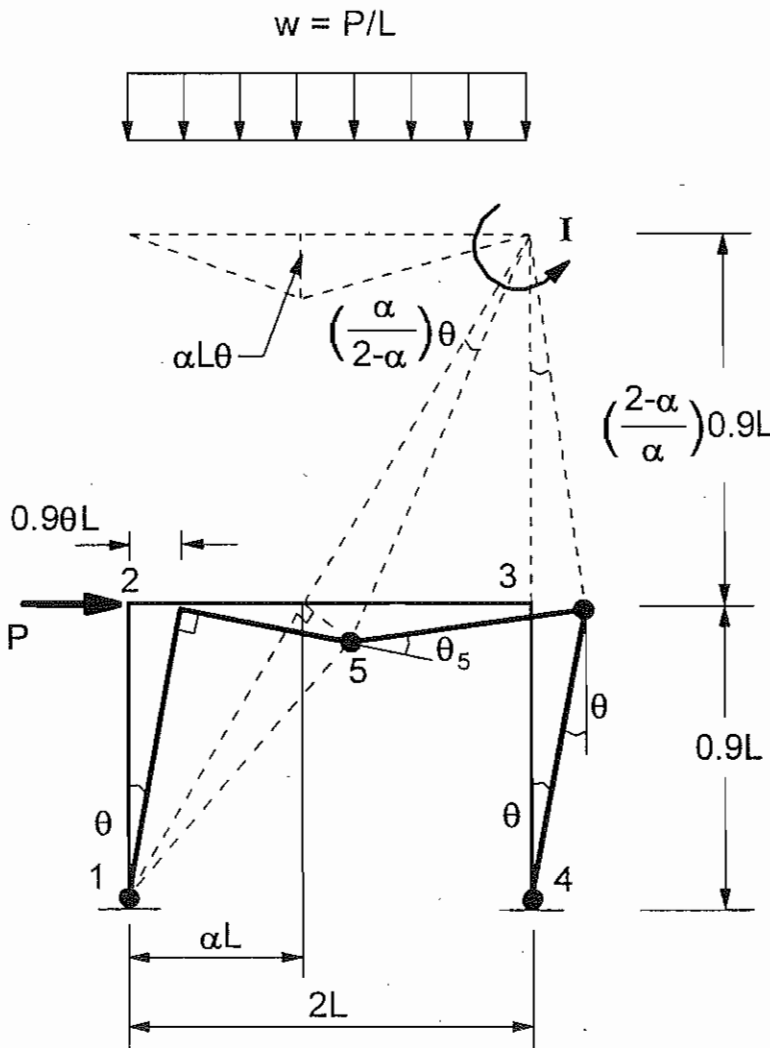

Rotations:

$$\theta_5 = \theta$$

$$\theta_{IC} = \frac{\theta \cdot 0.9L}{\frac{2-\alpha}{\alpha} \cdot 0.9L} = \frac{\alpha}{2-\alpha} \theta$$

$$\theta_4 = \theta_5 + \theta_{IC} = \frac{2}{2-\alpha} \theta$$

$$\theta_1 = \frac{\theta_{IC} \cdot (2L - \alpha L)}{\alpha L} = \theta$$

$$\theta_3 = \theta_{IC} + \theta_1 = \frac{2}{2-\alpha} \theta$$

Displacements:

$$\Delta_{2h} = \theta_1 \cdot 0.9L = 0.9L\theta$$

$$\Delta_{3v} = \theta_1 \cdot \alpha L = \alpha L\theta$$



Virtual work:

$$P \cdot 0.9L\theta + \frac{P}{L} \left( \frac{1}{2} \cdot 2L \cdot \alpha L \theta \right) = M_p \left( \theta + \frac{2}{2-\alpha} \theta + \frac{2}{2-\alpha} \theta + \theta \right)$$

$$P = \frac{8 - 2\alpha}{1.8 + 1.1\alpha - \alpha^2} \frac{M_p}{L}$$

Minimize the term  $PL/M_p$  and solve for  $\alpha$ :

$$\frac{dP}{d\alpha} = 0: \quad \alpha = 0.870$$

$$P_L = \frac{3.13 M_p}{L}$$

Reactions

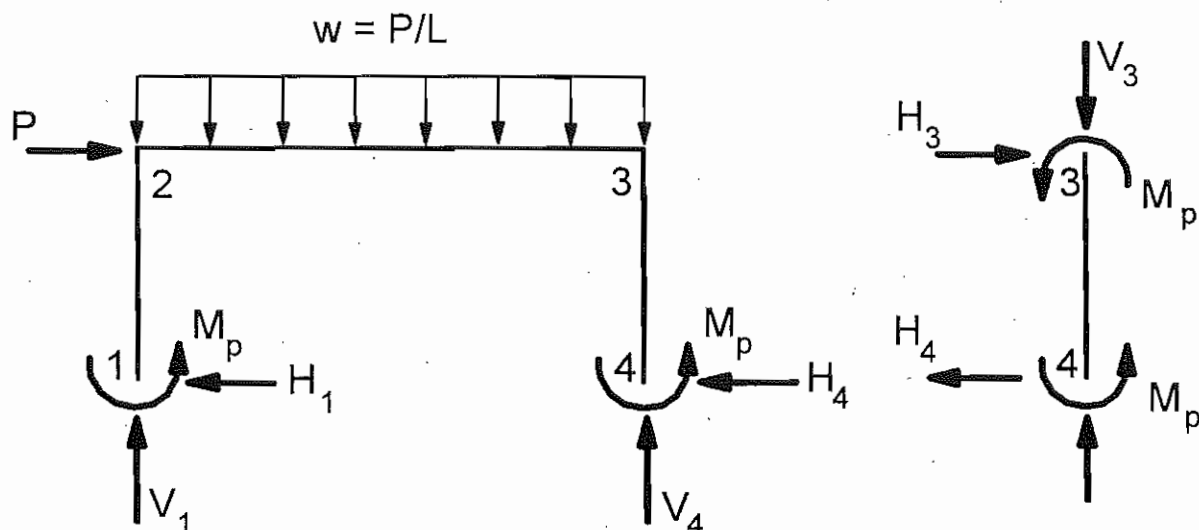

$$\sum M_3 = 0: \quad 2M_p - H_4 \cdot 0.9L = 0$$

$$H_4 = \frac{2.22 M_p}{L}$$

$$\sum H = 0: \quad P - H_1 - H_4 = 0$$

$$H_1 = P - H_4 = \frac{3.13 M_p}{L} - \frac{2.22 M_p}{L} = \frac{0.91 M_p}{L}$$

$$\sum M_1 = 0: \quad V_4 \cdot 2L + 2M_p - \frac{P}{L} \cdot 2L \cdot L - P \cdot 0.9L = 0$$

$$V_4 = -\frac{M_p}{L} + 1.45 \left( \frac{3.13 M_p}{L} \right) = \frac{3.54 M_p}{L}$$

$$\sum V = 0: \quad V_1 = \frac{P}{L} \cdot 2L - V_4 = 2 \left( \frac{3.13 M_p}{L} \right) - \frac{3.54 M_p}{L} = \frac{2.72 M_p}{L}$$

Moment equation for beam:

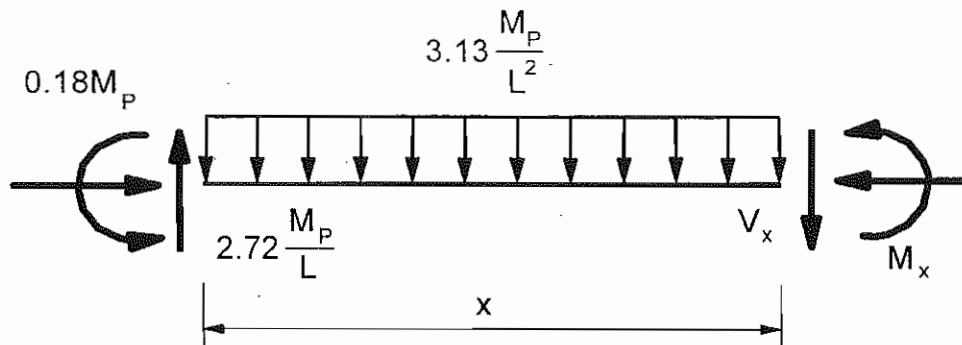

$$\sum M_x = 0: \quad 0.18 M_p - 2.72 \frac{M_p}{L} x + 3.13 \frac{M_p}{L^2} \frac{x^2}{2} + M_x = 0$$

$$M_x = 2.72 \frac{M_p}{L} x - 3.13 \frac{M_p}{L^2} \frac{x^2}{2} - 0.18 M_p$$

$$\frac{dM_x}{dx} = 2.72 \frac{M_p}{L} - 3.13 \frac{M_p}{L^2} x = 0$$

$$x = \frac{2.72}{3.13} L = 0.870 L$$

$$P \cdot 0.9\theta L + \frac{P}{L} \left( \frac{1}{2} \cdot 2L \cdot \theta L \right) = M_p (\theta + 2\theta + 2\theta + \theta)$$

$$P_L = \frac{3.16 M_p}{L}$$

Reaction and moment diagram:

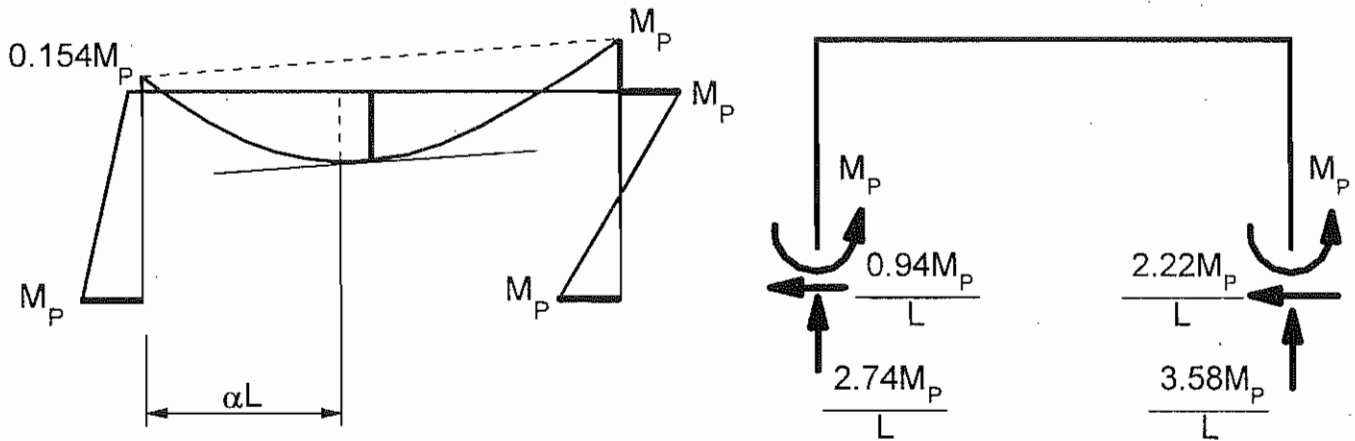

Maximum span moment:

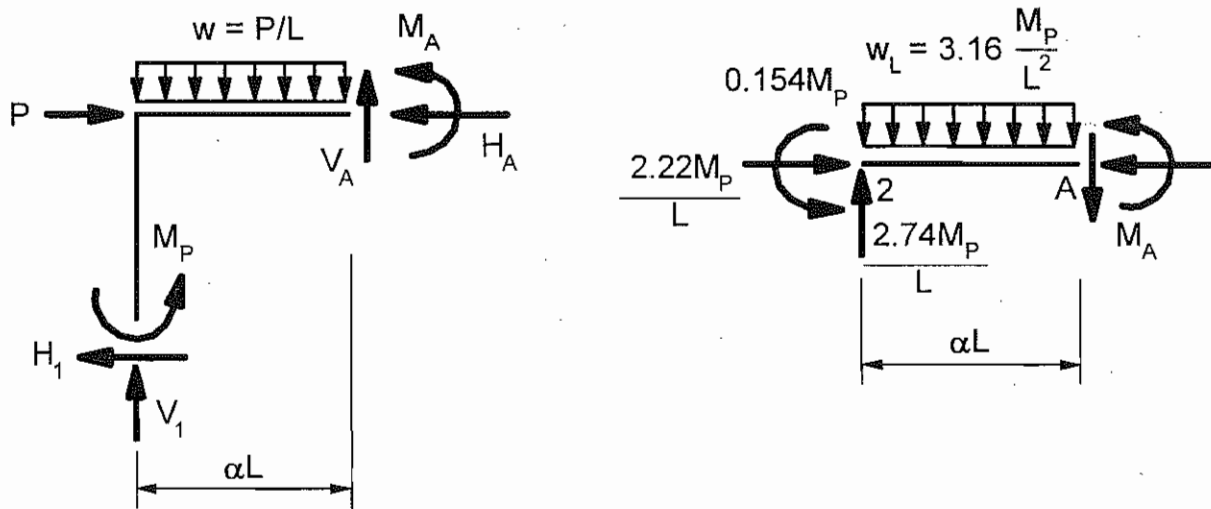

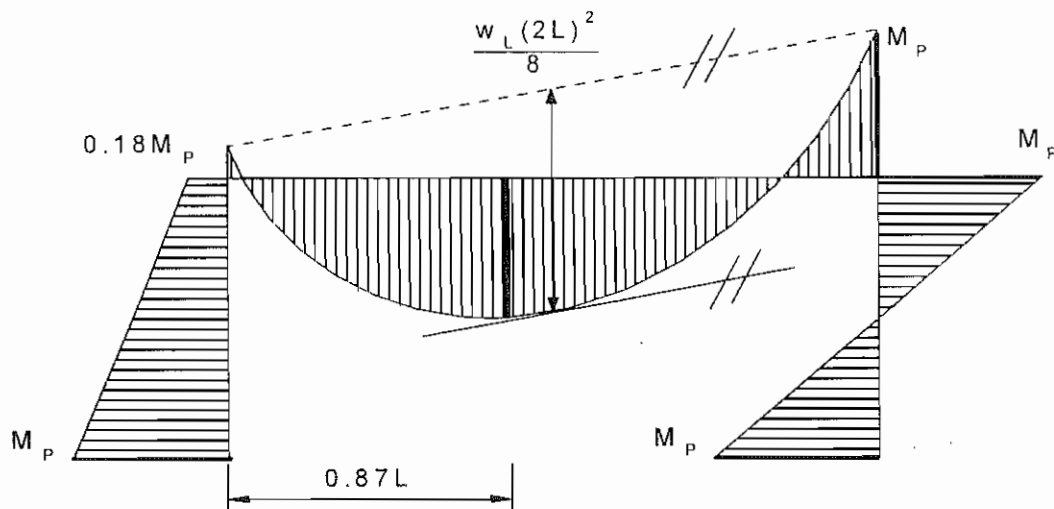

### Approximate Analysis for the Combined Mechanism

Limit load, assuming hinge forms at midspan:

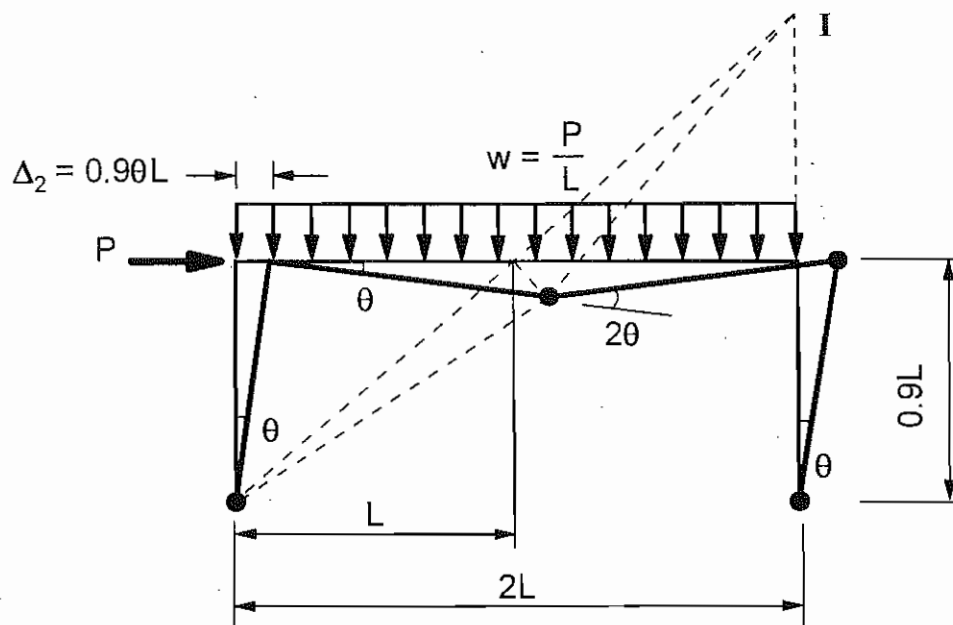

$$\sum M_A = 0: \quad 0.154 M_p - \frac{2.74 M_p}{L} (\alpha L) + \frac{3.16 M_p (\alpha L)^2}{L^2 \cdot 2} + M_A = 0$$

$$M_A = -1.58 M_p (\alpha^2) + 2.74 M_p (\alpha) - 0.154 M_p$$

$$\frac{\partial M_A}{\partial \alpha} = 0 \quad \rightarrow \quad \alpha = 0.870$$

So:

$$M_A = 1.034 M_p > M_p$$

Bounds on exact solution :

$$P_L < 3.16 \frac{M_p}{L}$$

$$P_L > \frac{3.16 M_p / L}{1.034} = 3.06 \frac{M_p}{L}$$

Exact solution (page 3.4-19):

$$P_L = 3.13 \frac{M_p}{L}$$

3.4.9 EXAMPLE 7: TWO-BAY FRAME — COMBINATION OF MECHANISMS

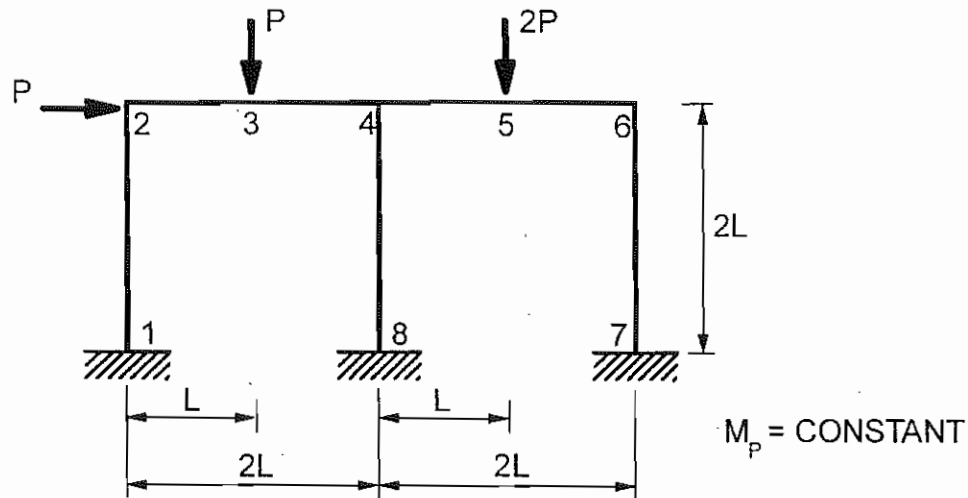

Number of independent mechanisms:

$$n = N - x = 10 - 6 = 4$$

Number of independent and combined mechanisms:

$$N_{mech} = 2^n - 1 = 15$$

Independent Mechanisms

(1) Beam mechanism 1:

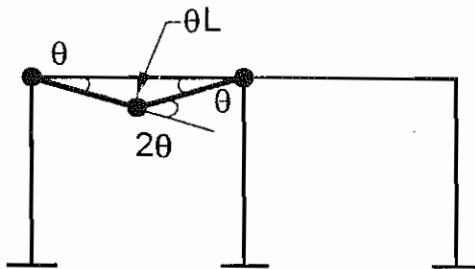

$$P \cdot \theta L = M_p \cdot 4\theta$$

$$P_L = \frac{4M_p}{L}$$

(2) Beam mechanism 2:

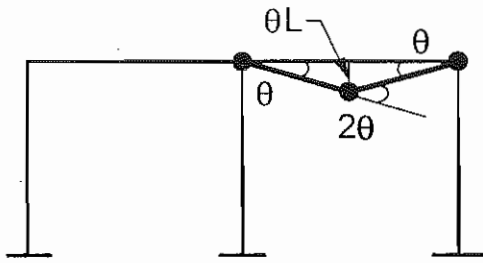

(Most critical)

$$2P_L \theta L = M_p \cdot 4\theta$$

$$P_L = \frac{2M_p}{L}$$

(3) Panel mechanism:

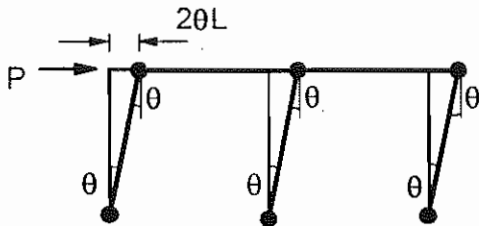

$$P \cdot 2\theta L = M_p \cdot 6\theta$$

$$P_L = \frac{3M_p}{L}$$

(4) Joint mechanism:

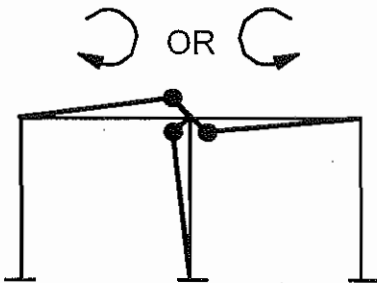

$$W_E = 0$$

$$W_I = 3\theta M_p$$

### Combined Mechanisms

(5) Mechanisms 1 and 2 (no physical meaning:

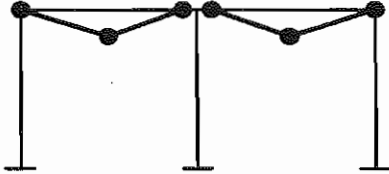

$$1 : P \theta L = 4 M_p \theta$$

$$2 : 2 P \theta L = 4 M_p \theta$$

$$1+2 : 3 P \theta L = 8 M_p \theta$$

$$\therefore P_L = 2.67 \frac{M_p}{L}$$

(6) Mechanisms 1 and 3:

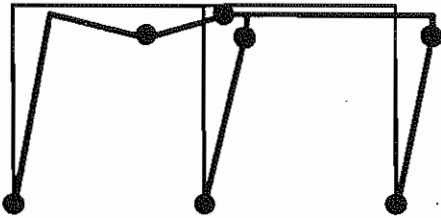

$$1 : P \theta L = 4 M_p \theta$$

$$3 : 2 P \theta L = 6 M_p \theta$$

$$-1 : -M_p \theta$$

$$-3 : -M_p \theta$$

$$3 P \theta L = 8 M_p \theta$$

$$\therefore P_L = 2.67 \frac{M_p}{L}$$

(7) Mechanisms 1 and 4:

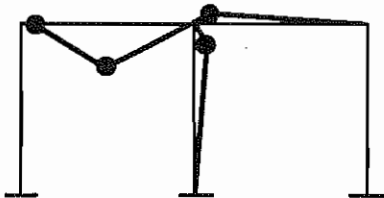

$$1 : P \theta L = 4 M_p \theta$$

$$4 : 0 = 3 M_p \theta$$

$$-1 : -M_p \theta$$

$$-4 : -M_p \theta$$

$$P \theta L = 5 M_p \theta$$

$$\therefore P_L = 5 \frac{M_p}{L}$$



(8) Mechanisms 2 and 3:

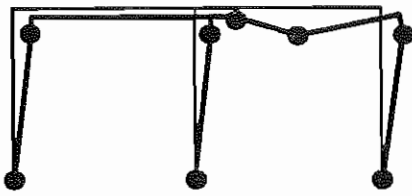

$$\begin{aligned}
 2 : \quad & 2P\theta L = 4M_p\theta \\
 3 : \quad & 2P\theta L = 6M_p\theta \\
 & 4P\theta L = 10M_p\theta \\
 \therefore P_L &= 2.5 \frac{M_p}{L}
 \end{aligned}$$

(9) Mechanisms 2 and 4:

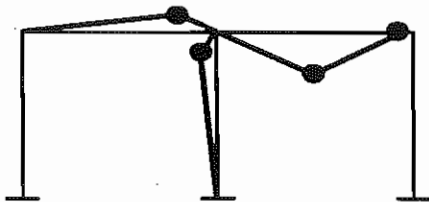

$$\begin{aligned}
 2 : \quad & 2P\theta L = 4M_p\theta \\
 4 : \quad & 0 = 3M_p\theta \\
 -2 : \quad & -M_p\theta \\
 -4 : \quad & -M_p\theta \\
 & 2P\theta L = 5M_p\theta \\
 \therefore P_L &= 2.5 \frac{M_p}{L}
 \end{aligned}$$

(10) Mechanisms 3 and 4

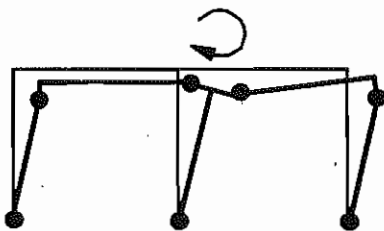

$$\begin{aligned}
 3 : \quad & 2P\theta L = 6M_p\theta \\
 4 : \quad & 0 = 3M_p\theta \\
 -3 : \quad & -M_p\theta \\
 -4 : \quad & -M_p\theta \\
 & 2P\theta L = 7M_p\theta \\
 \therefore P_L &= 3.5 \frac{M_p}{L}
 \end{aligned}$$

(11) Mechanisms 1, 2 and 3:

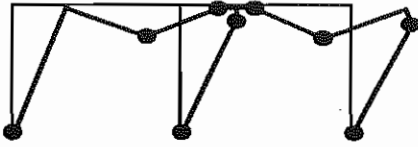

$$\begin{aligned}
 1 : & \quad P\theta L = 4 M_p \theta \\
 2 : & \quad 2P\theta L = 4 M_p \theta \\
 3 : & \quad 2P\theta L = 6 M_p \theta \\
 -1 : & \quad -M_p \theta \\
 -3 : & \quad -M_p \theta \\
 & \quad 5P\theta L = 12 M_p \theta \\
 \therefore P_L & = 2.4 \frac{M_p}{L}
 \end{aligned}$$

(12) Mechanisms 1, 2 and 4:

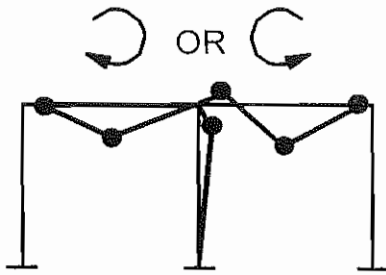

$$\begin{aligned}
 1 : & \quad P\theta L = 4M_p\theta \\
 2 : & \quad 2P\theta L = 4M_p\theta \\
 4 : & \quad 0 = 3M_p\theta \\
 -1 : & \quad -M_p\theta \\
 -4 : & \quad -M_p\theta \\
 & \quad 3P\theta L = 9M_p\theta \\
 \therefore & \quad P_L = 3\frac{M_p}{L}
 \end{aligned}$$

(13) Mechanisms 1, 3 and 4:

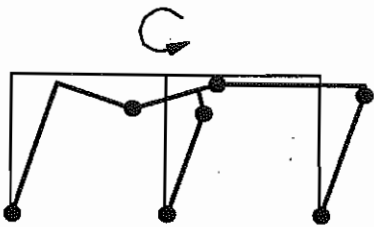

$$\begin{aligned}
 1 : & \quad P \theta L = 4 M_p \theta \\
 3 : & \quad 2 P \theta L = 6 M_p \theta \\
 4 : & \quad 0 = 3 M_p \theta \\
 -1 : & \quad - 2 M_p \theta \\
 -3 : & \quad - M_p \theta \\
 -4 : & \quad - M_p \theta \\
 & \quad 3 P \theta L = 9 M_p \theta \\
 & \quad \therefore P_L = 3 \frac{M_p}{L}
 \end{aligned}$$

(14) Mechanisms 2, 3 and 4:

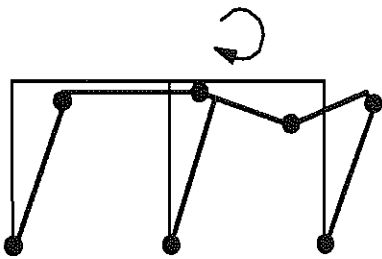

(Third most critical)

$$\begin{aligned}
 2 : & \quad 2 P \theta L = 4 M_p \theta \\
 3 : & \quad 2 P \theta L = 6 M_p \theta \\
 4 : & \quad 0 = 3 M_p \theta \\
 -2, -3, -4 : & \quad - 4 M_p \theta \\
 & \quad 4 P \theta L = 9 M_p \theta \\
 & \quad \therefore P_L = 2.25 \frac{M_p}{L}
 \end{aligned}$$

(15) Mechanisms 1, 2, 3 and 4:

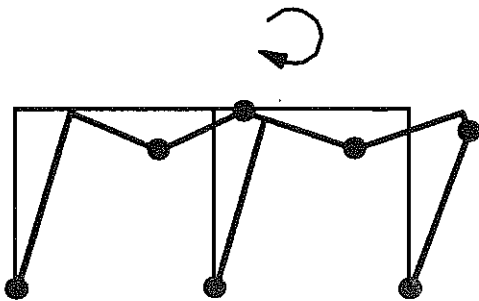

(Second most critical)

$$\begin{aligned}
 1, 2 \text{ and } 3 : & \quad 5 P \theta L = 14 M_p \theta \\
 4 : & \quad 0 = 3 M_p \theta \\
 -1, -3 : & \quad - 2 M_p \theta \\
 -2, -3, -4 : & \quad - 4 M_p \theta \\
 & \quad 5 P \theta L = 11 M_p \theta \\
 & \quad \therefore P_L = 2.2 \frac{M_p}{L}
 \end{aligned}$$



### 3.5 MEMBERS OF NONUNIFORM CROSS SECTION

#### 3.5.1 TAPERED MEMBER

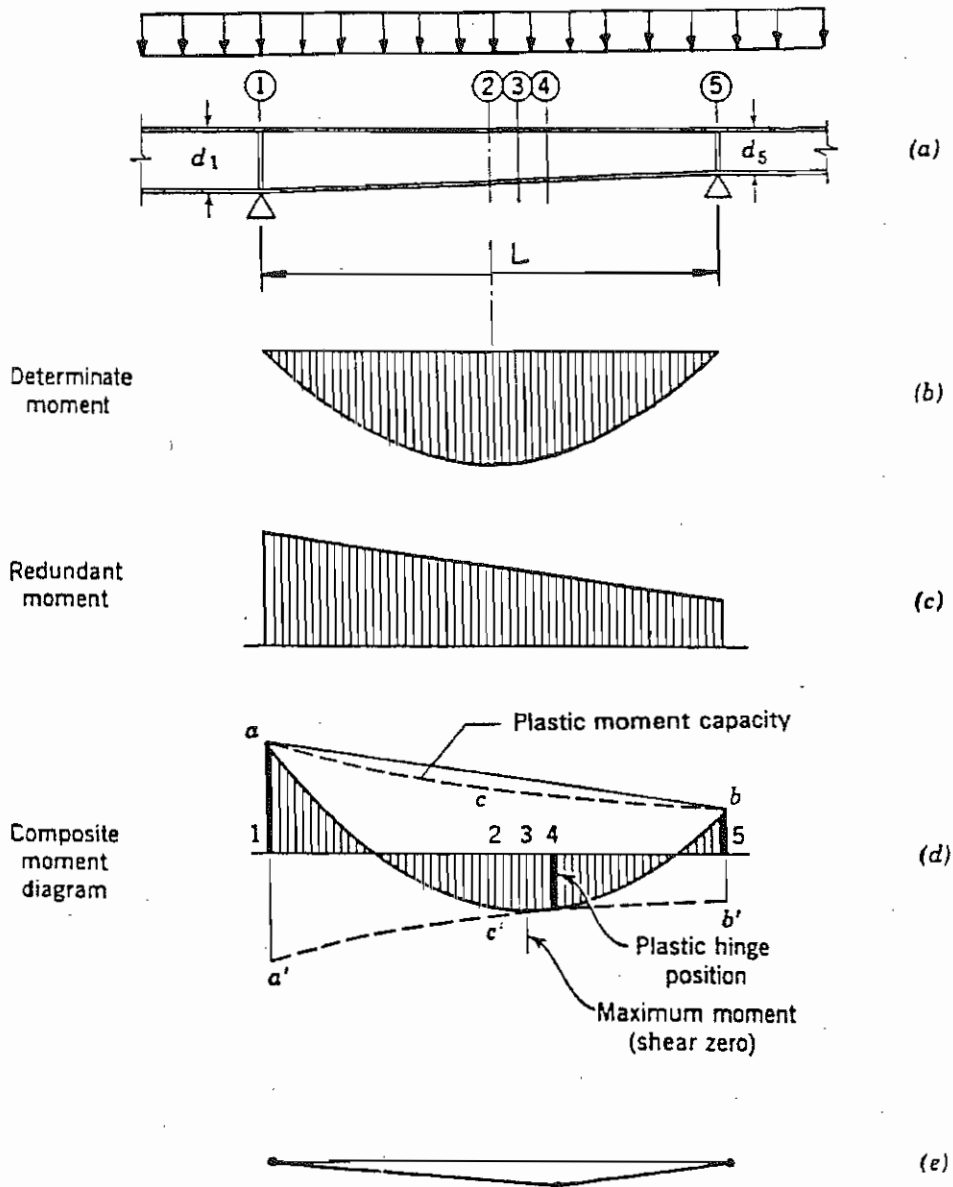
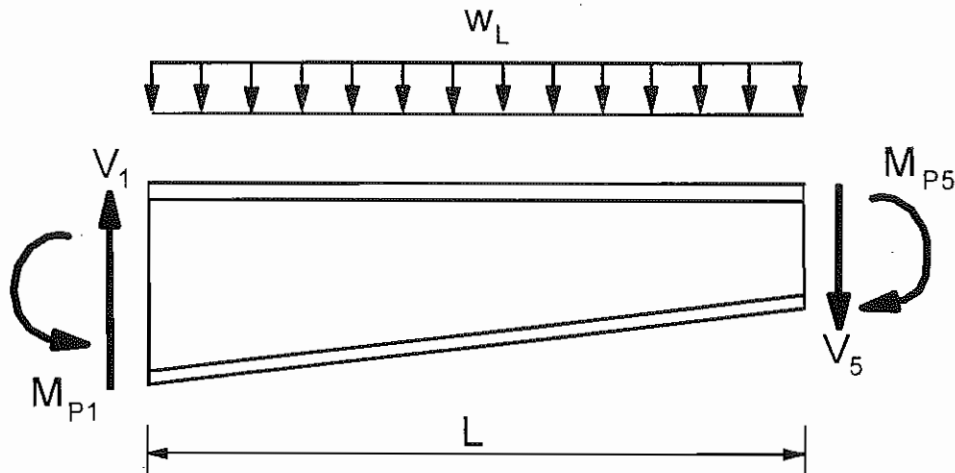

FIG. 3.5.1. Plastic Analysis of Tapered Member (Beedle 1958, p. 97)

In tapered and uniformly loaded members, the hinge in the positive moment region does not form where the moment is maximum (zero shear). Instead, it

forms where the bending moment diagram induced by the applied loads and the diagram of plastic moment capacity have the same slopes and ordinates.

### Bending Moment Diagram



$$\sum M_5 = 0: \quad -V_1 \cdot L + \frac{w_L L^2}{2} + M_{p1} - M_{p5} = 0$$

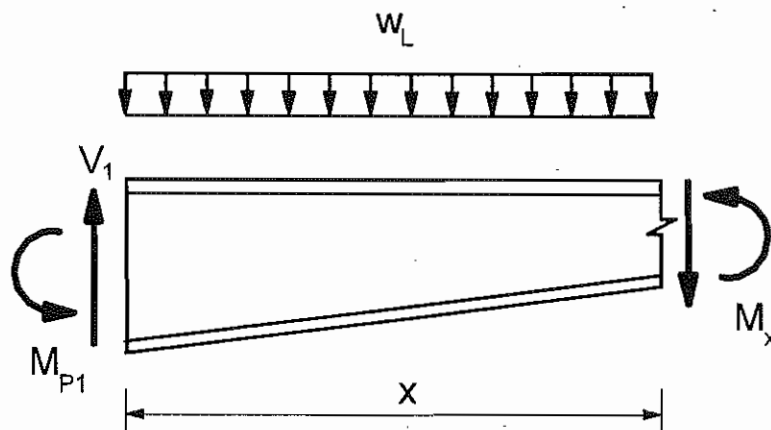

$$\sum M_x = 0: \quad -V_1 \cdot x + \frac{w_L x^2}{2} + M_{p1} + M_x = 0$$

Eliminate  $V_1$  and solve for  $M_x$ :

$$M_x = \left( \frac{w_L L}{2} + \frac{M_{p1} - M_{p2}}{L} \right) x - \frac{w_L x^2}{2} - M_{p1}$$

### Plastic Moment Capacity

$$M_{px} = \pm Z_x \sigma_y$$

where the plastic modulus for a tapered beam with a wide flange section is

$$Z_x = b_f t_f \left[ d_1 - \frac{x}{L} (d_1 - d_2) - t_f \right] + \frac{t_w}{4} \left[ d_1 - \frac{x}{L} (d_1 - d_2) - t_f \right]^2$$

### Limit Load

The plastic hinge position  $x$  and the limit load  $w_L$  are obtained by equating the slopes and ordinates of the bending moment diagram and the diagram of plastic moment capacity:

$$\frac{dM_x}{dx} = \frac{dM_{px}}{dx}$$

$$M_x = M_{px}$$



3.5.2 COVERPLATED AND HAUNCHED MEMBERS

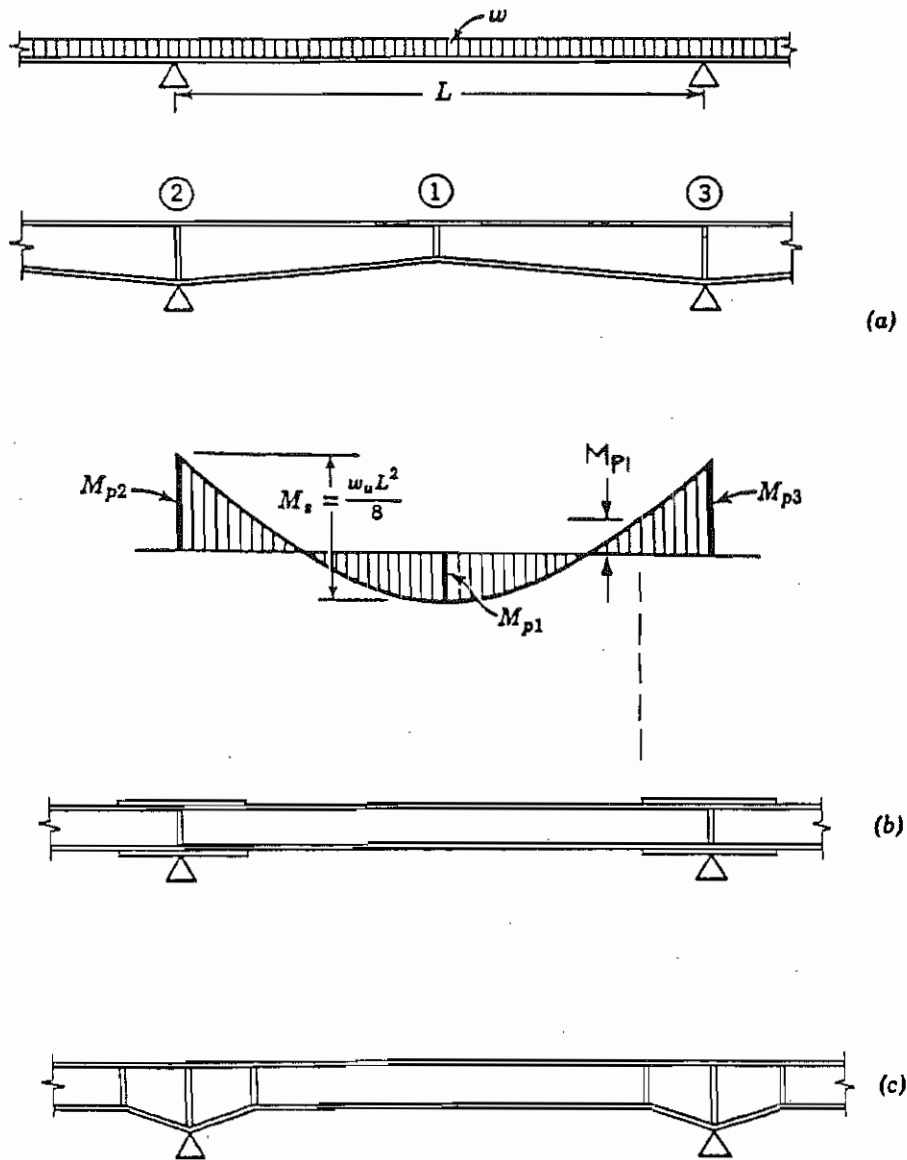

FIG. 3.5.2. Plastic Analysis of Members with Prismatic Cross Section in Positive Moment Region (Beedle 1958, p. 94)

In contrast to tapered members, coverplated and haunched members are typically prismatic along the positive bending moment region where the diagram of plastic moment capacity has a zero slope

$$\frac{dM_{px}}{dx} = 0$$

and constant ordinate

$$M_{px} = Z\sigma_y = \text{constant}$$

where the plastic modulus for a prismatic beam with a wide flange section is

$$Z = b_f t_f (d - t_f) + \frac{t_w}{4} (d - 2t_f)^2$$

### Limit Load

The plastic hinge position  $x$  and the limit load  $w_L$  are, again, obtained by equating the slopes and ordinates of the bending moment diagram and the diagram of plastic moment capacity:

$$\frac{dM_x}{dx} = \frac{w_L L}{2} + \frac{M_{p1} - M_{p2}}{L} - w_L x = 0$$

$$M_x = \left( \frac{w_L L}{2} + \frac{M_{p1} - M_{p2}}{L} \right) x - \frac{w_L x^2}{2} - M_{p1} = Z\sigma_y$$

## 3.6 TESTS OF CONTINUOUS STRUCTURES

### 3.6.1 RECAPITULATION OF ASSUMPTIONS

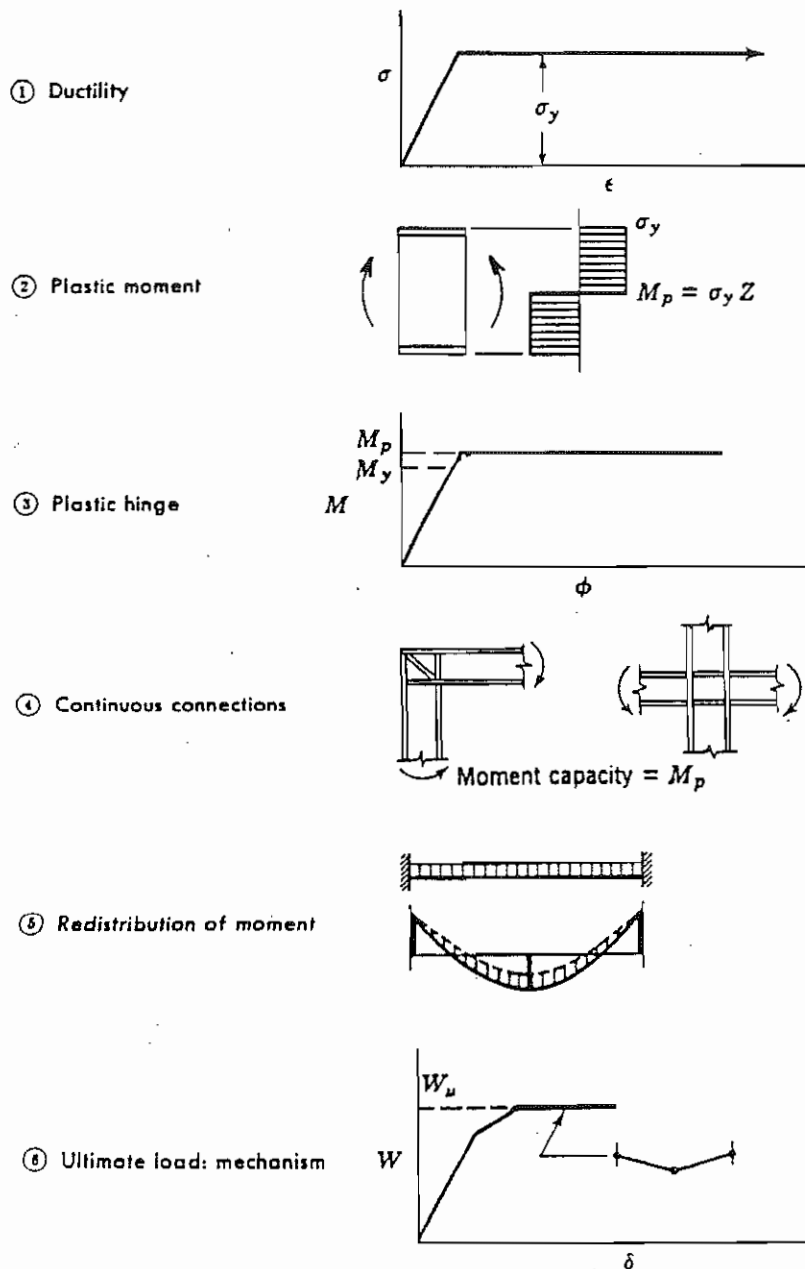
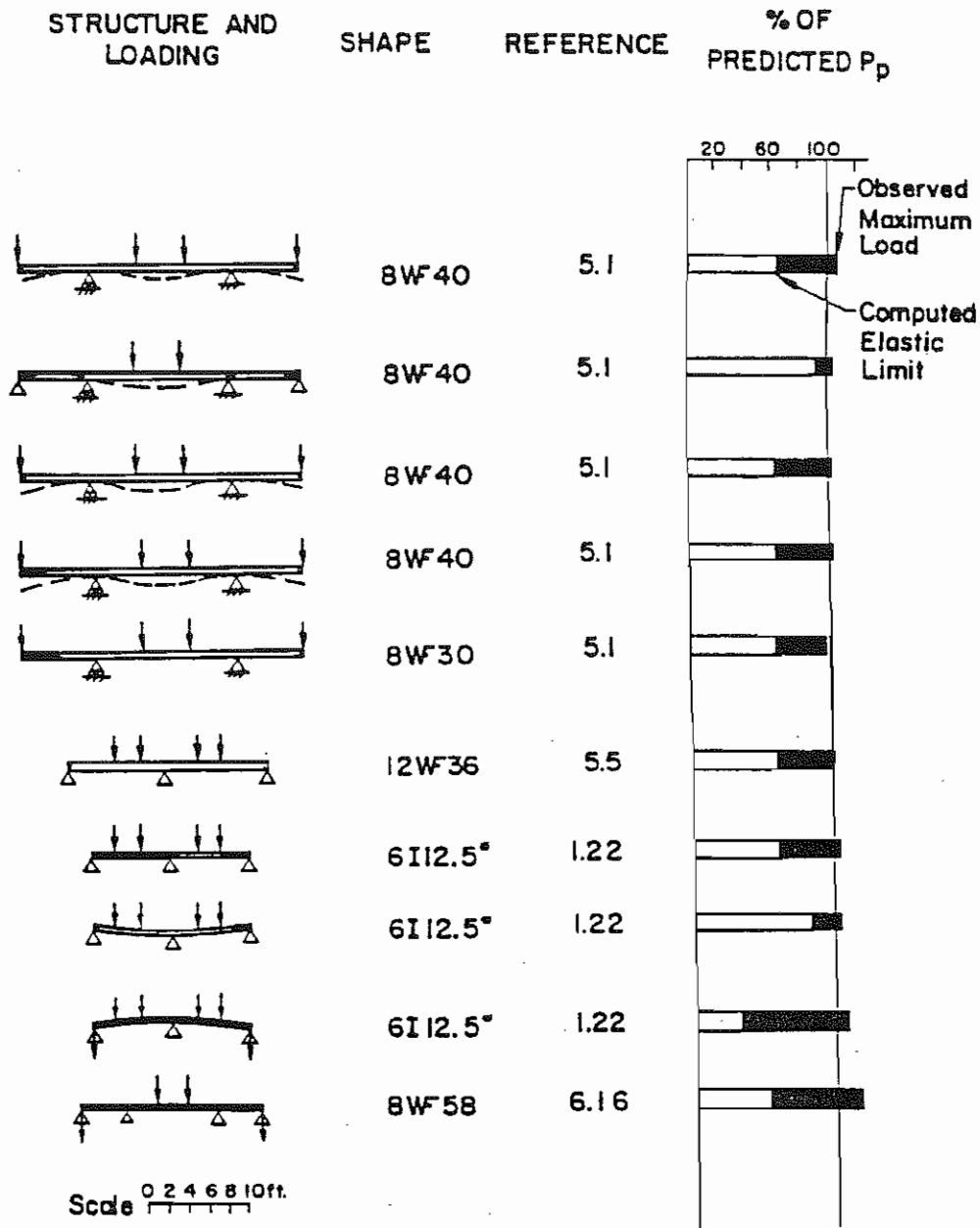

FIG. 3.6.1. Important Assumptions in Plastic Analysis  
(Beedle 1958, p. 99)

### 3.6.2 STRENGTH OF CONTINUOUS BEAMS



\*(German St. 37 Steel, 37 Steel)

FIG. 3.6.2. Summary of Test Results for Continuous Beams Showing Correlation with Predictions of Plastic Theory (Plastic Design 1971, p. 50)

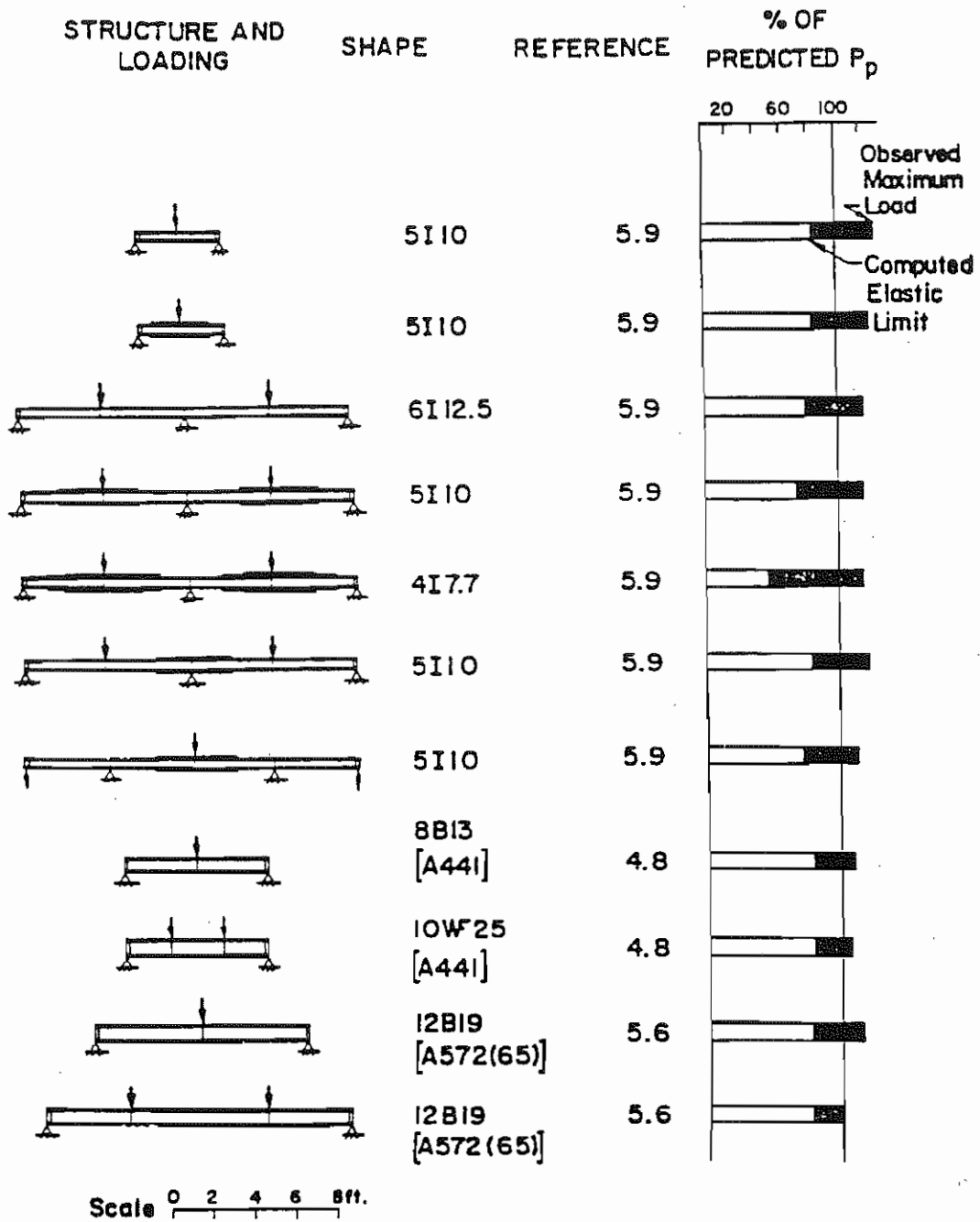

FIG. 3.6.3. Summary of Test Results for Beams Showing Correlation with Predictions of Plastic Theory (Plastic Design 1971, p.51)

3.6.3 STRENGTH OF RIGID FRAMES

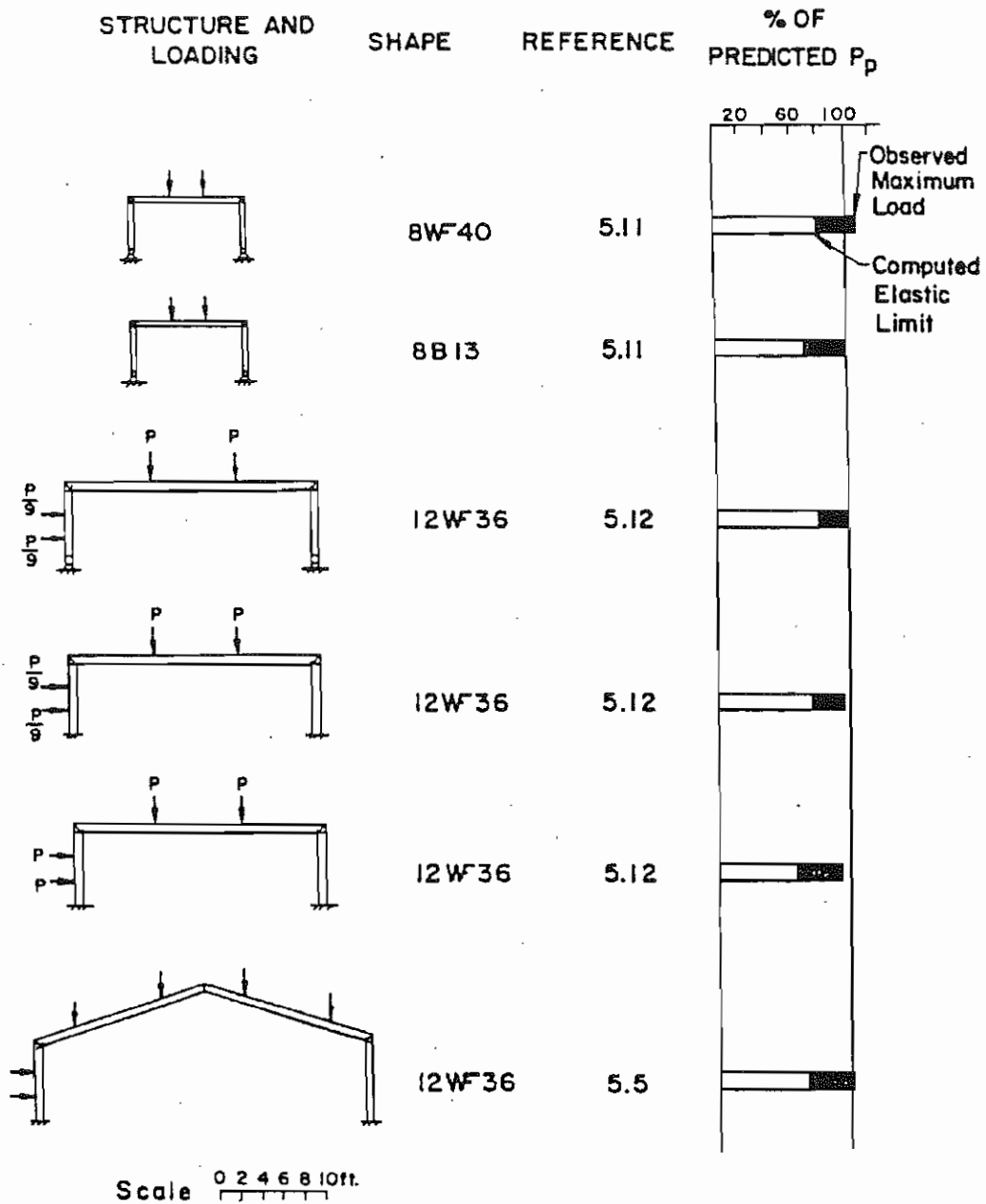

FIG. 3.6.4. Summary of Test Results for Frames Showing Correlation with Predictions of Plastic Theory (Plastic Design 1971, p. 54)

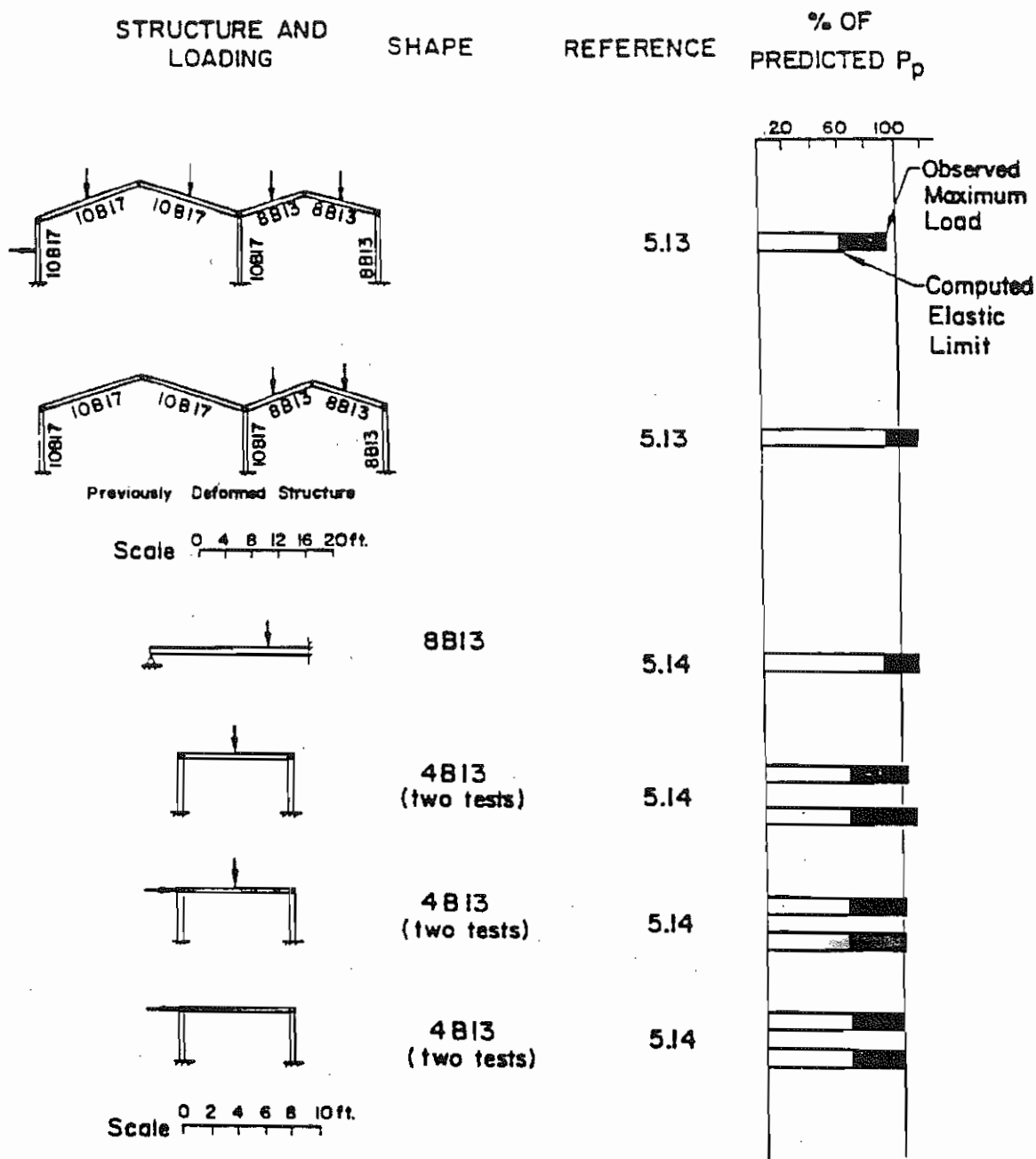

FIG. 3.6.5. Summary of Test Results for Frames Showing Correlation with Predictions of Plastic Theory (Plastic Design 1971, p. 55)for

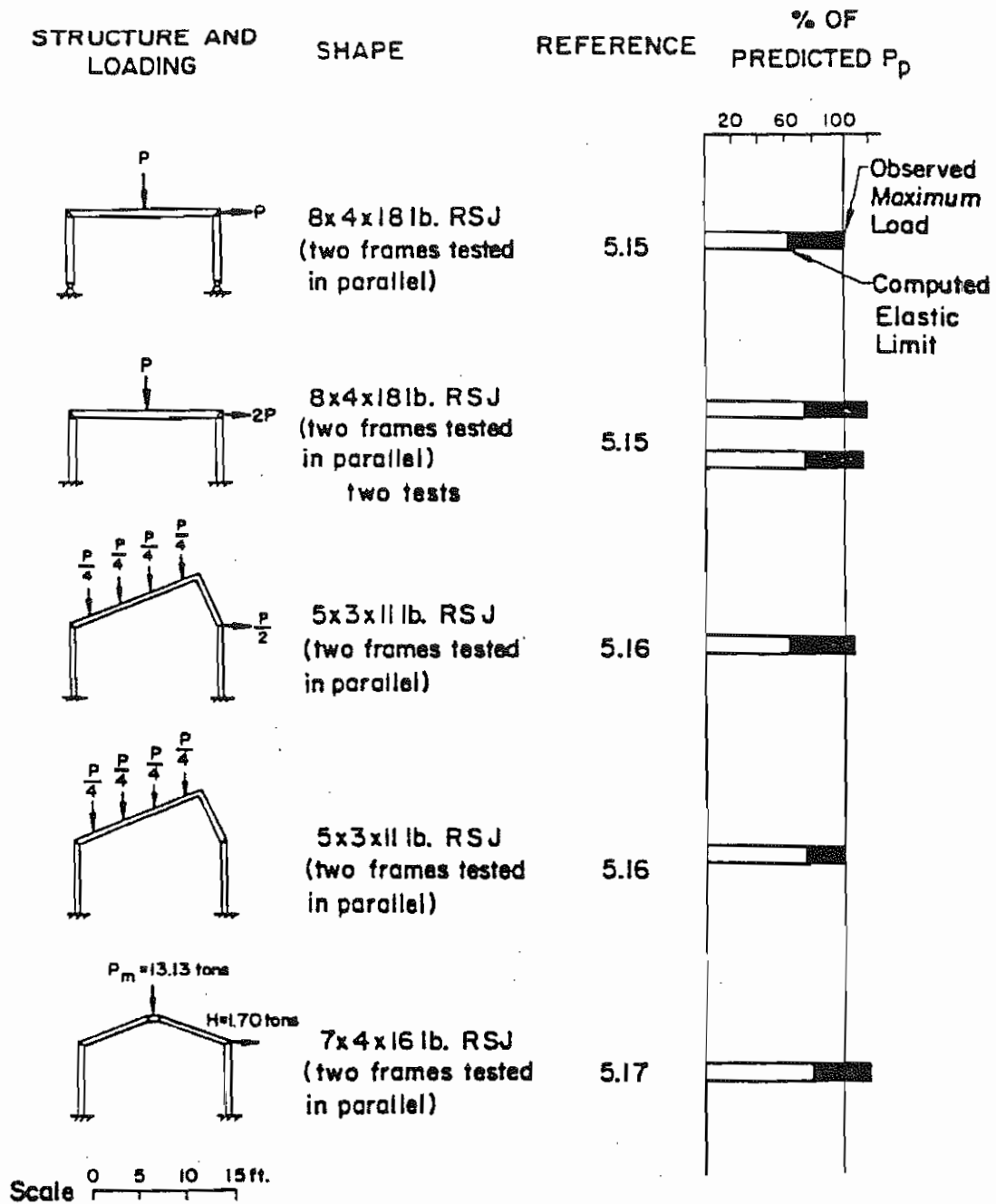

FIG. 3.6.6. Summary of Test Results for Frames Showing Correlation with Predictions of Plastic Theory (Plastic Design 1971, p. 56)



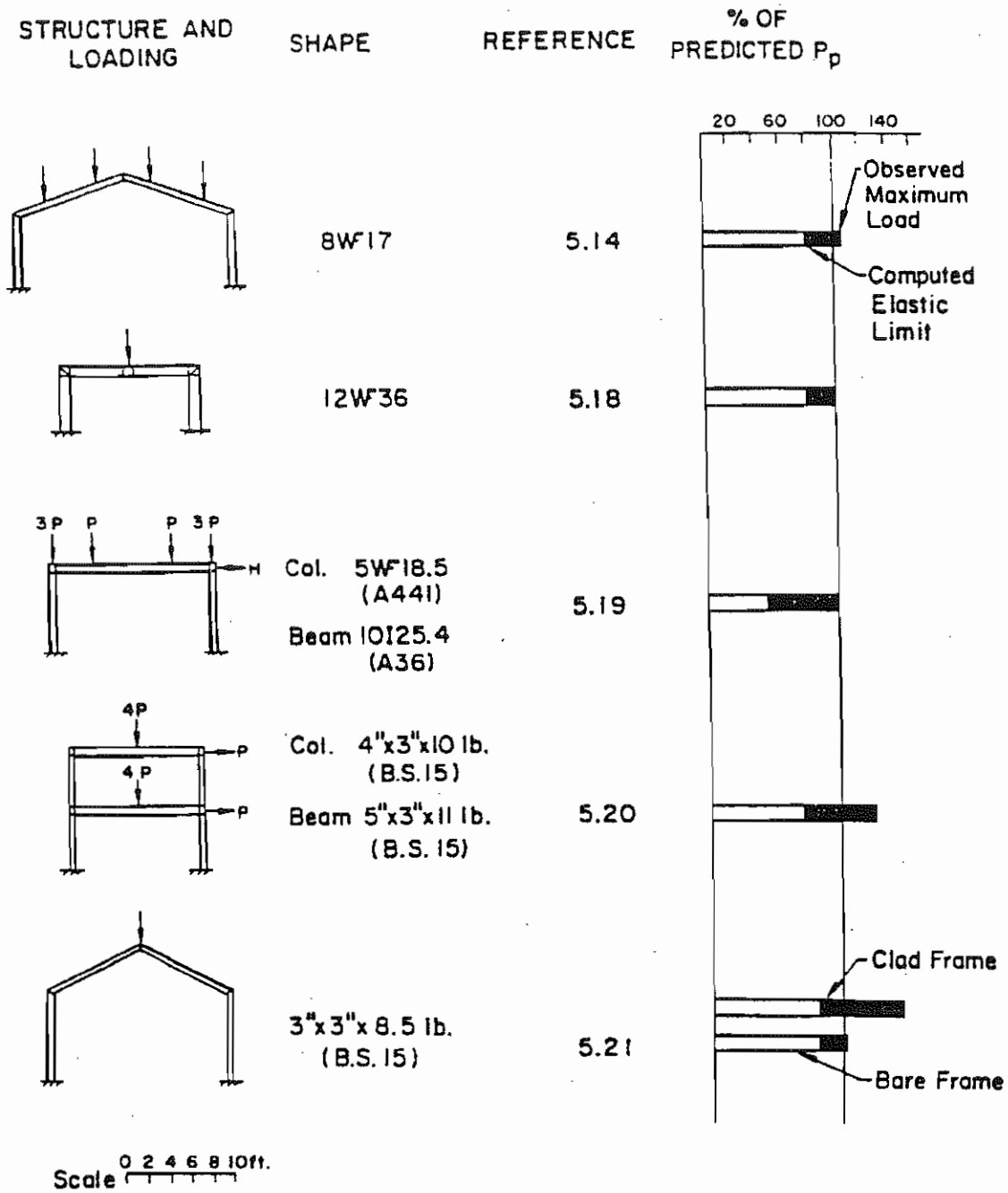

FIG. 3.6.7. Summary of Test Results for Frames Showing Correlation with Predictions of Plastic Theory (Plastic Design 1971, p. 57)

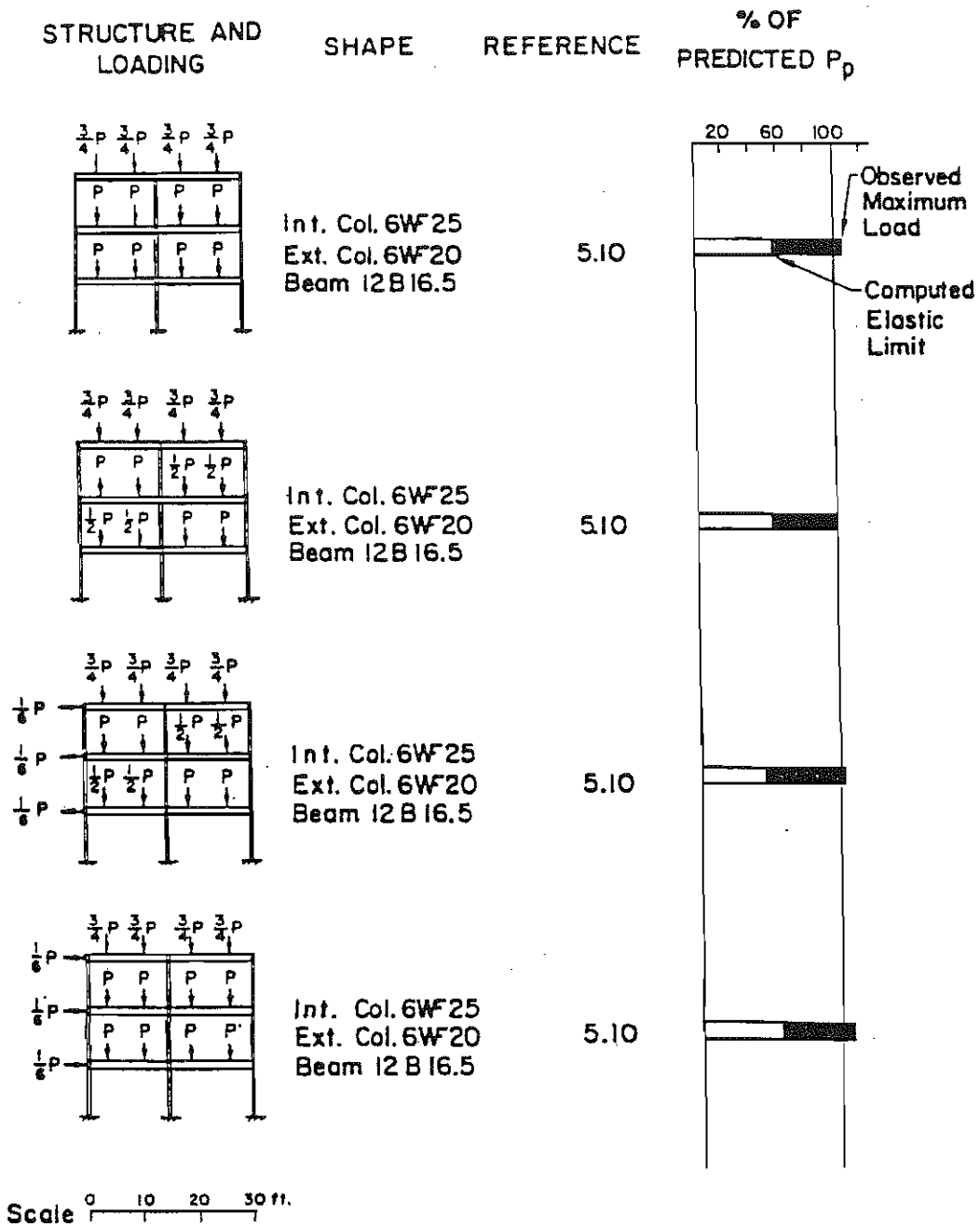

FIG. 3.6.8. Summary of Test Results for Braced Frames Showing Correlation with Predictions of Plastic Theory (Plastic Design 1971, p. 58)