

# **Pavement Analysis and Design**

**TE-503A**

**Lecture-2**  
**16-09-2019**

**Dr. Zia-ur-Rehman**  
**DTEM**

## Stresses and Strains in Flexible Pavements

- Stress: force per unit area

$$\sigma = \frac{\text{Load}}{\text{Area}} = \frac{P}{A}$$

- Strain

$$\varepsilon = \frac{\text{Change in Length}}{\text{Original Length}} = \frac{\Delta L}{L}$$

# Stresses and Strains in Flexible Pavements

- Stiffness = stress/strain

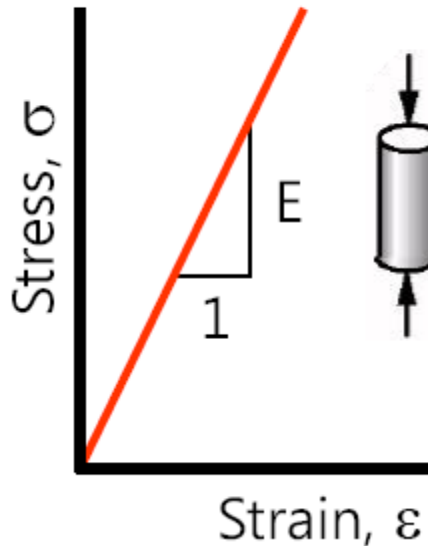

- For elastic materials :
  - Modulus of Elasticity
  - Elastic Modulus
  - Young's Modulus

# Stresses and Strains in Flexible Pavements

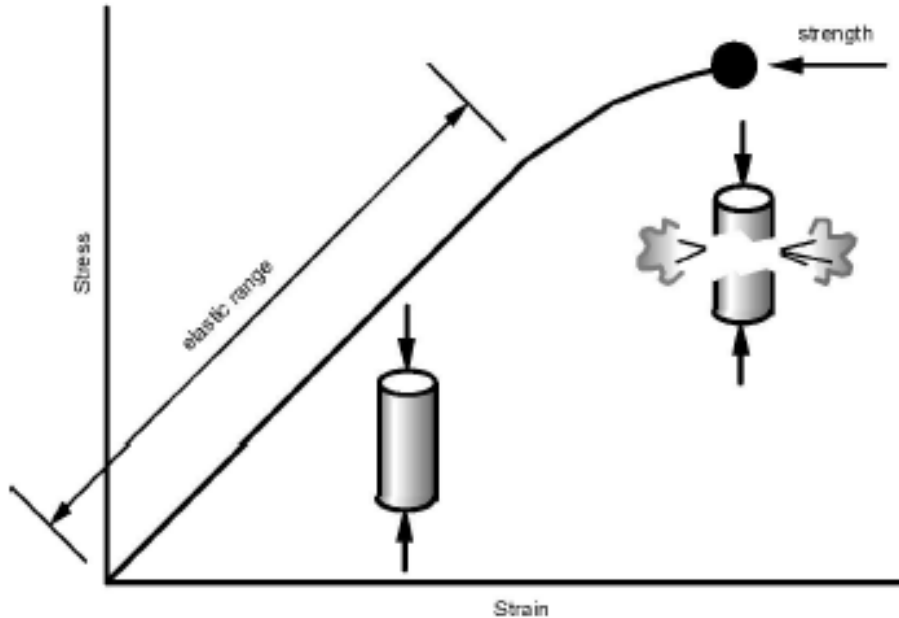

# Stresses and Strains in Flexible Pavements

## Poisson's Ratio

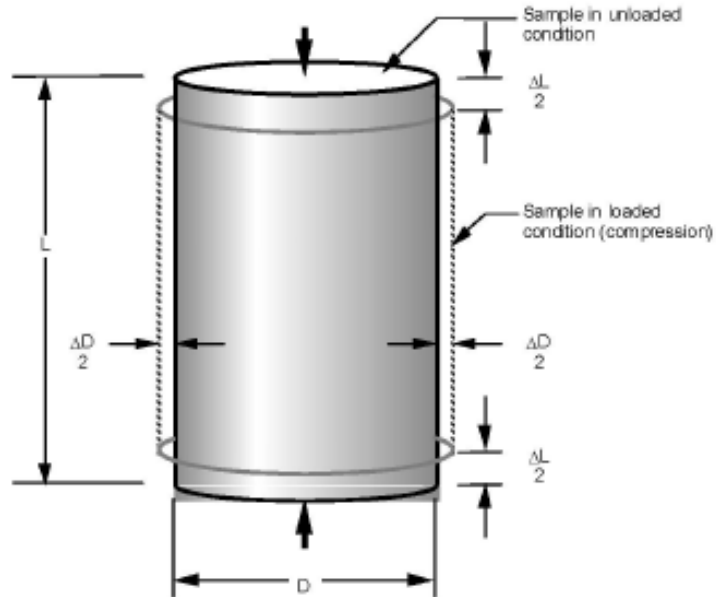

$$\mu = - \frac{\epsilon_D}{\epsilon_L}$$

# Stresses and Strains in Flexible Pavements

## Deflection

- Change in length.
- Deformation.
- Units: mm, mils (0.001 in).

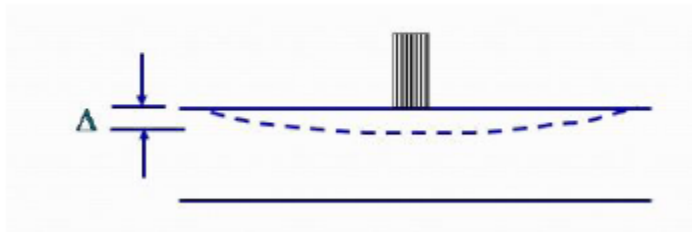

# Stresses and Strains in Flexible Pavements

- Homogeneous
  - The same in all locations
- Isotropic
  - The same in all directions

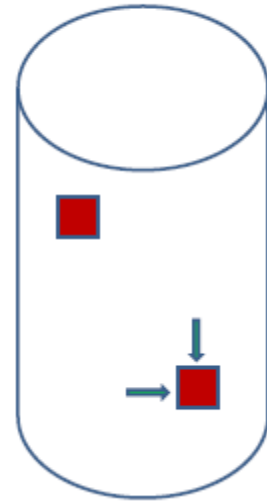

# Stresses and Strains in Flexible Pavements

**Since the mid 1960, pavement researchers have been refining mechanistically based design methods.**

**While the mechanics of layered systems are well developed, there remains much work to be done in the areas of material characterization and failure criteria.**

**The horizontal strain is used to predict and control fatigue cracking in the surface layer.**

**With respect to asphalt concrete pavements, the current failure criteria used are the horizontal tensile strain at the bottom of the asphalt concrete layer and the vertical strain at the top of the subgrade.**



## Stresses and Strains in Flexible Pavements

**There has been very little effort placed on the refinement of the subgrade failure criteria.**

**The development of the current subgrade failure criteria, which limits the amount of vertical strain on top of the subgrade, is based primarily on limited data from the AASHO Road Test.**

**Similarly the vertical strain at the top of the subgrade is used to predict and control permanent deformation (rutting) of the pavement structure caused by shear deformation in the upper subgrade.**

# Stresses and Strains in Flexible Pavements

## Approaches

**Layered elastic method**

**Two-dimensional finite element method**

**Three-dimensional finite element method**

# Stresses and Strains in Flexible Pavements

## **Layered Elastic Approach**

**It is the most popular and easily understood procedure.**

**In this method, the system is divided into an arbitrary number of horizontal layers.**

**The thickness of each individual layer and material properties may vary from one layer to the next, but in any one layer the material is assumed to be homogeneous and linear elastic.**

**These shortcomings make it difficult to simulate realistic scenarios.**

# Stresses and Strains in Flexible Pavements

## **Layered Elastic Approach**

**Although the layered elastic method is more easily implemented than finite element methods, it still has severe limitations: materials must be homogenous and linearly elastic within each layer, and the wheel loads applied on the surface must be axisymmetric.**

**It is very hard to rationally accommodate material non-linearity and incorporate spatially varying tyre contact pressures, which can significantly affect the behaviour of the pavement systems.**

# Stresses and Strains in Flexible Pavements

## **2D Finite Element Analysis**

**Plane strain or axis-symmetric conditions are generally assumed.**

**Compared to the layered elastic method, the practical applications of this method are greater, as it can rigorously handle material anisotropy, material nonlinearity, and a variety of boundary conditions.**

**Unfortunately, 2D models can not accurately capture non-uniform tyre contact pressure and multiple wheel loads.**

# Stresses and Strains in Flexible Pavements

## **3D Finite Element Analysis**

To overcome the limitations inherent in 2D modeling approaches, 3D finite element models are becoming more wide spread.

With 3D FE analysis, we can study the response of flexible pavements under spatially varying tyre pavement contact pressures.

# Stresses and Strains in Flexible Pavements

## Stress and Strain in Flexible Pavement

Pavement structural analysis includes three main issues: **material characterization**, theoretical model for structural response and **environmental**.

Three aspects of the material behaviour are typically considered for pavement analysis:

- The relationship between the stress and strain(linear or nonlinear).
- The time dependency of strain under a constant load (viscous or non-viscous).
- The degree to which the material can recover strain after stress removal (elastic or plastic).

# Stresses and Strains in Flexible Pavements

## **Stress and Strain in Flexible Pavement**

**Theoretical response models for the pavement are typically based on a continuum mechanics approach.**

**The model can be a closed-formed analytical solution or a numerical approach.**

**Various theoretical response models have been developed with different levels of sophistication from analytical solutions such as Boussinesq's equations based on elasticity to three-dimensional dynamic finite element models.**



# Stresses and Strains in Flexible Pavements

## **Pavement Response**

**Flexible and rigid pavements respond to loads in very different ways.**

**Consequently, different theoretical models have been developed for flexible and rigid pavements.**

# Stresses and Strains in Flexible Pavements

## Pavement Response

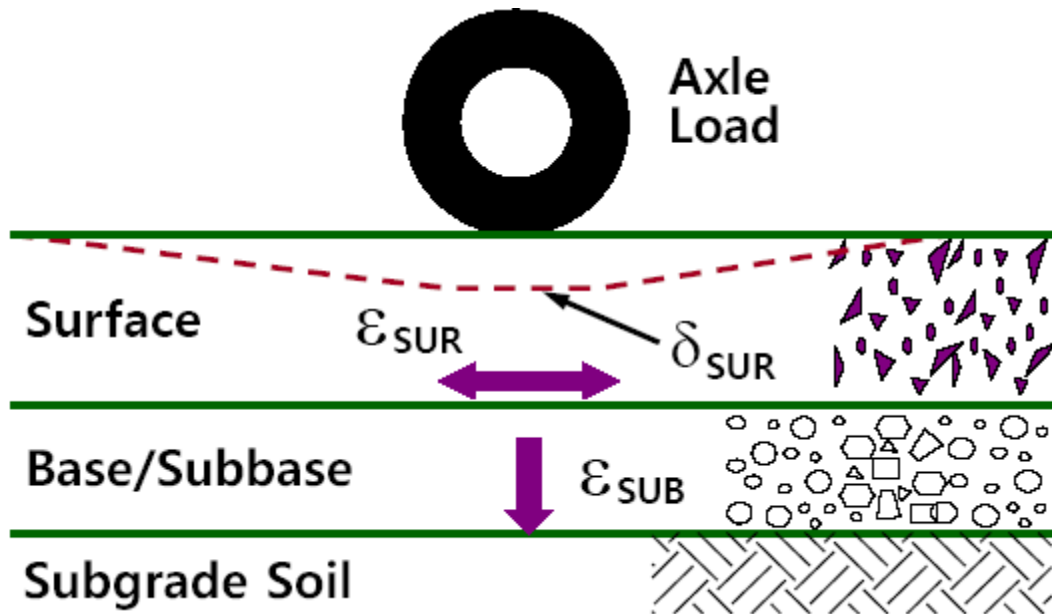

# Stresses and Strains in Flexible Pavements

## **Homogeneous Mass**

**The simplest way to characterize the behaviour of a flexible pavement under wheel loads is to consider it as a homogeneous half-space.**

**A half-space has an infinitely large area and an infinite depth with a top plane on which the loads are applied.**

**The original Boussinesq (1885) theory was based on a concentrated load applied on an elastic half-space.**

**The stresses, strains, and deflections due to a concentrated load can be integrated to obtain those due to a circular loaded area.**

# Stresses and Strains in Flexible Pavements

## Homogeneous Mass

- Boussinesq (1885)

Point load on an elastic half-space

- Examine  $\sigma$  distribution along Z & X

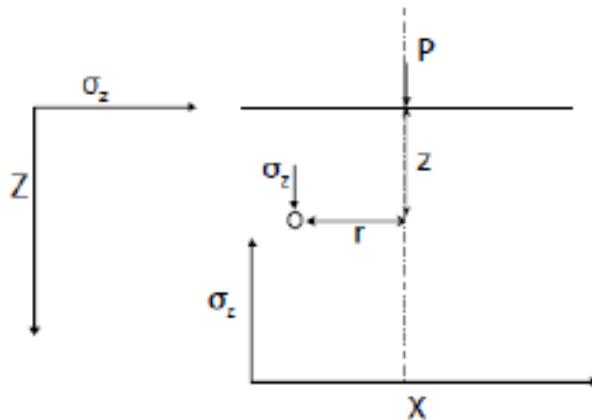

$$\sigma_z = K \frac{P}{z^2}$$

$$K = \frac{3}{2\pi} \frac{1}{\left[1 + (r/z)^2\right]^{5/2}}$$

## Stresses and Strains in Flexible Pavements

### **Homogeneous Mass**

**Before the development of layered theory by Burmister (1943), much attention was paid to Boussinesq solutions because they were the only ones available.**

**The theory can be used to determine the stresses, strains, and deflections in the subgrade if the modulus ratio between the pavement and the subgrade is close to unity, as exemplified by a thin asphalt surface and a thin granular base.**

# Stresses and Strains in Flexible Pavements

## Single Layer Solutions

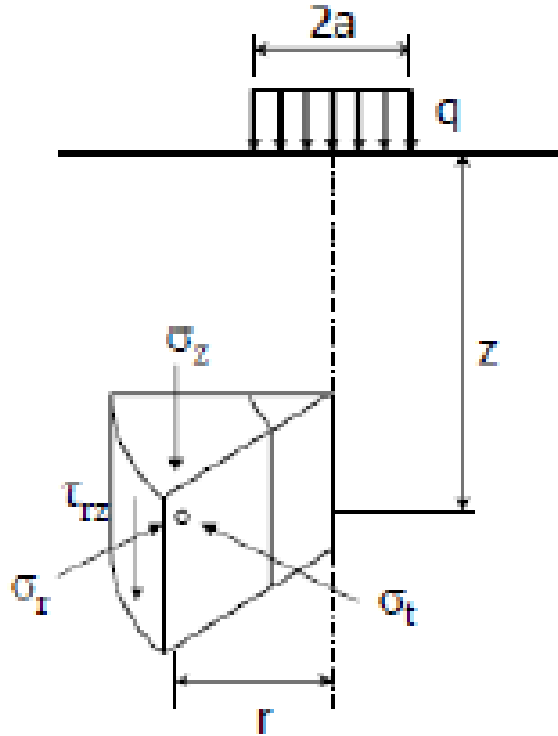

# Stresses and Strains in Flexible Pavements

## Single Layer Solutions

Figure shows a homogeneous half-space subjected to a circular load with a radius  $a$  and a uniform pressure  $q$ .

The half-space has an elastic modulus  $E$  and a Poisson ratio  $\nu$ .

A small cylindrical element with center at a distance  $z$  below the surface and  $r$  from the axis of symmetry is shown.

Because of axisymmetry, there are only three normal stresses,  $\sigma_z$ ,  $\sigma_r$  and  $\sigma_\theta$  and one shear stress,  $\tau_{rz}$  which is equal to  $\tau_{zr}$ . These stresses are functions of  $q$ ,  $r/a$ , and  $z/a$ .

# Stresses and Strains in Flexible Pavements

## Single Layer Solutions

**Foster and Ahlvin (1954) presented charts for determining vertical stress, radial stress, tangential stress, shear stress, and vertical deflection  $\omega$ , as shown in Figures 2.2 through 2.6.**

**The load is applied over a circular area with a radius  $a$  and intensity  $q$ .**



# Stresses and Strains in Flexible Pavements

## Single Layer Solutions-Vertical stress

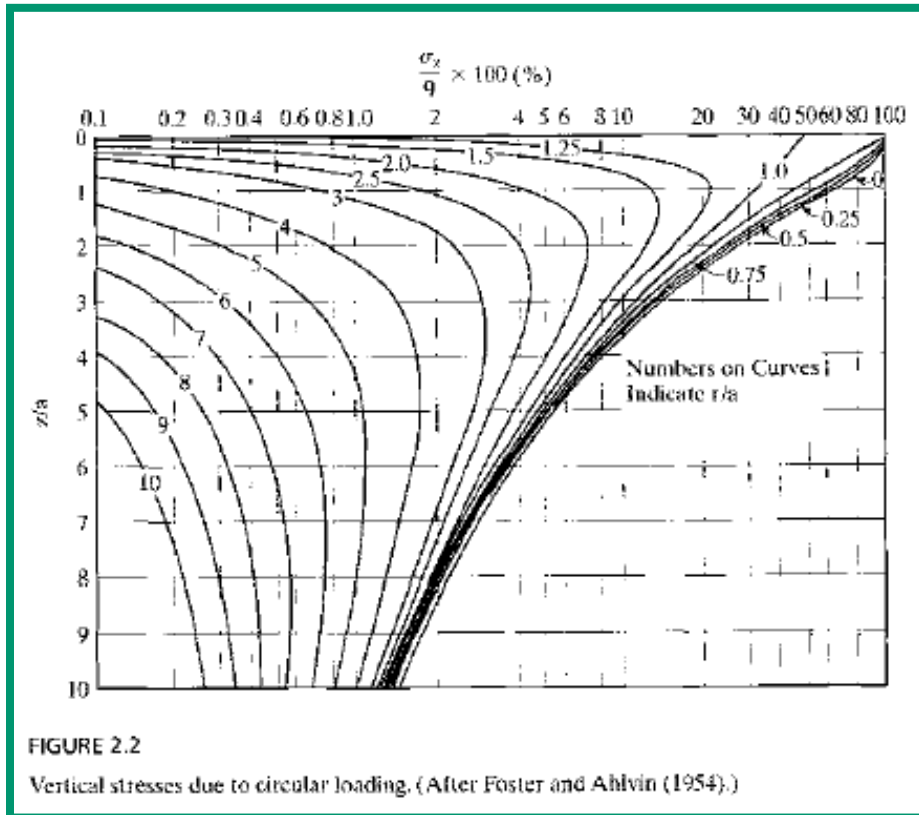

# Stresses and Strains in Flexible Pavements

## Single Layer Solutions-Radial stress

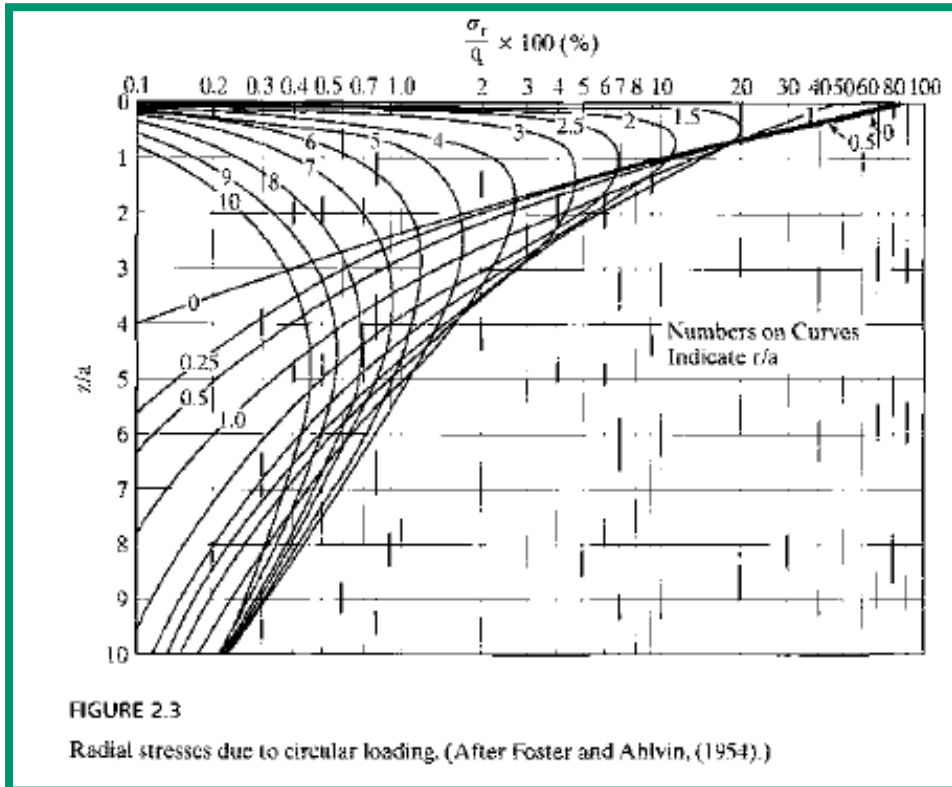

# Stresses and Strains in Flexible Pavements

## Single Layer Solutions-Tangential stress

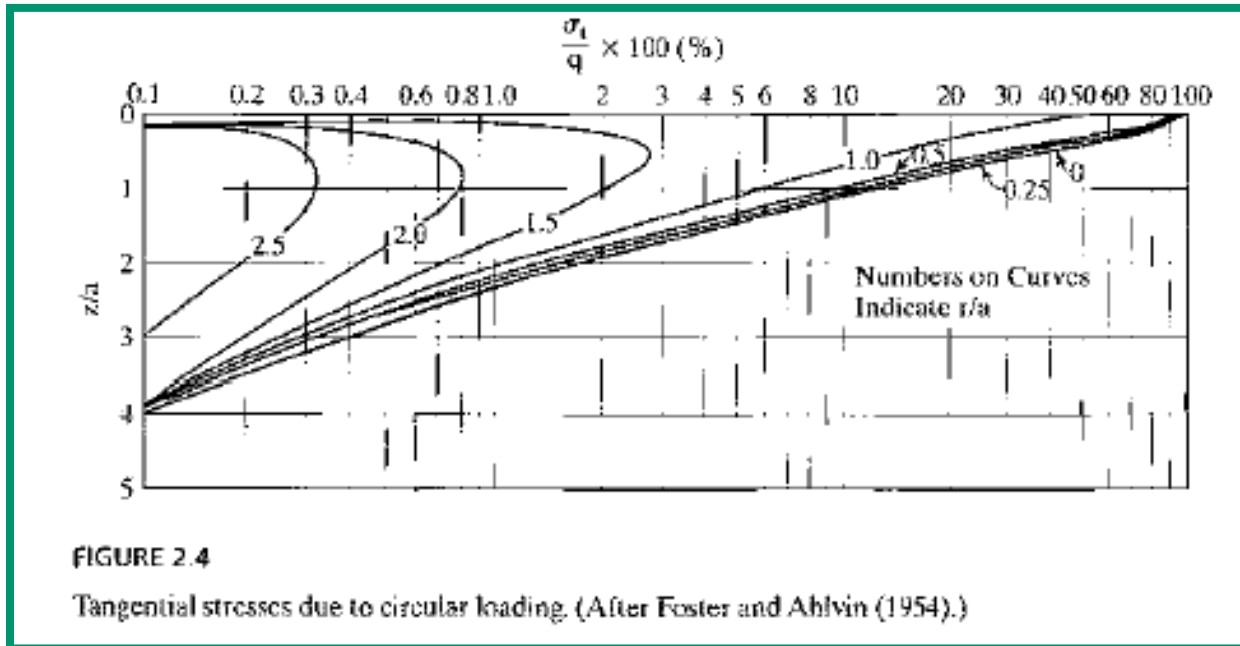

# Stresses and Strains in Flexible Pavements

## Single Layer Solutions-Shear stress

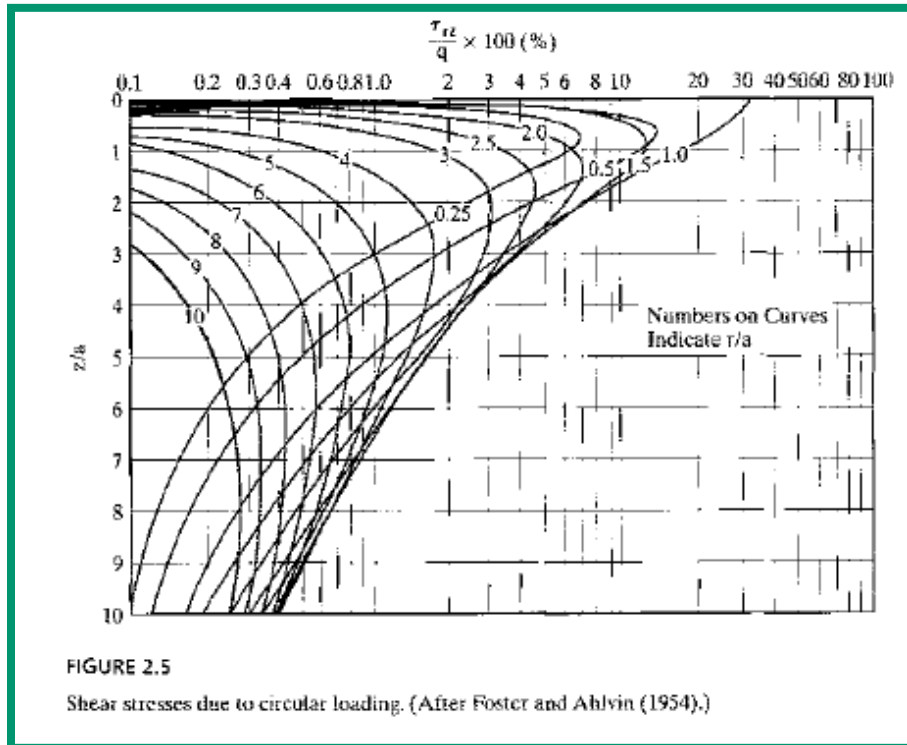

# Stresses and Strains in Flexible Pavements

## Single Layer Solutions-Vertical deflection

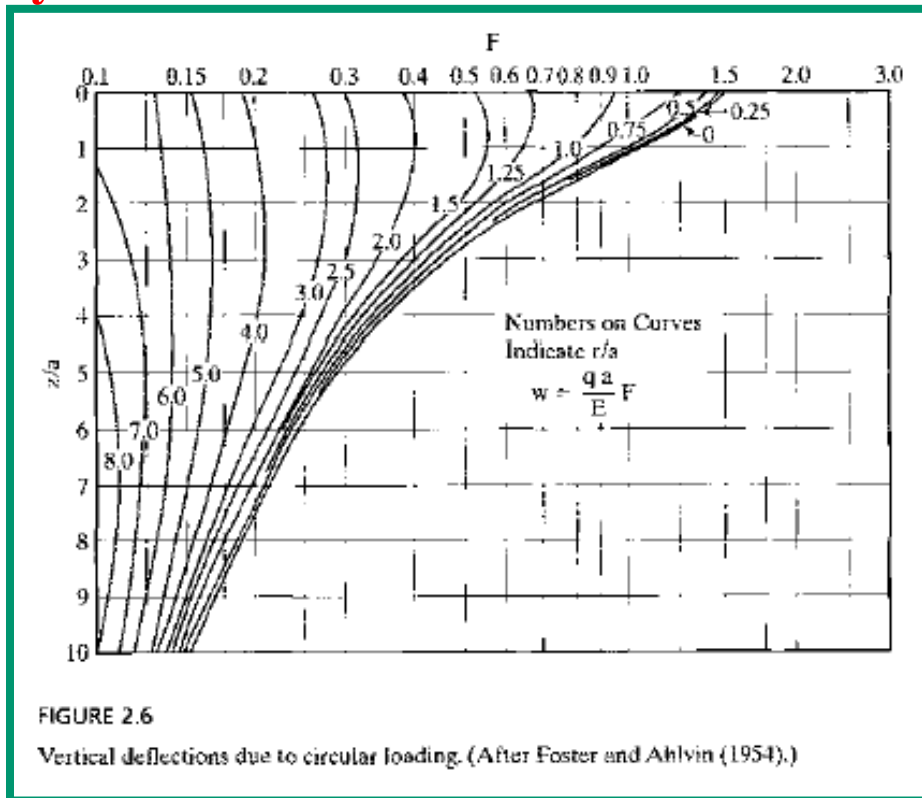

FIGURE 2.6

Vertical deflections due to circular loading. (After Foster and Ahlvin (1954).)

# Stresses and Strains in Flexible Pavements

## Single Layer Solutions-Strains

After the stresses are obtained from the charts, the strains can be obtained using the following equations:

$$\epsilon_z = \frac{1}{E} [\sigma_z - \nu(\sigma_r + \sigma_t)]$$

$$\epsilon_r = \frac{1}{E} [\sigma_r - \nu(\sigma_t + \sigma_z)]$$

$$\epsilon_t = \frac{1}{E} [\sigma_t - \nu(\sigma_z + \sigma_r)]$$

If the contact area consists of two circles, the stresses and strains can be computed by superposition.

# Stresses and Strains in Flexible Pavements

## Single Layer Solutions-Numerical Problem

Figure shows a homogeneous half-space subjected to two circular loads, each 10 in. in diameter and spaced at 20 in. on centers. The pressure on the circular area is 50 psi. The half-space has elastic modulus 10,000 psi and Poisson ratio 0.5. Determine the vertical stress, strain, and deflection at point A, which is located 10 in. below the center of one circle.

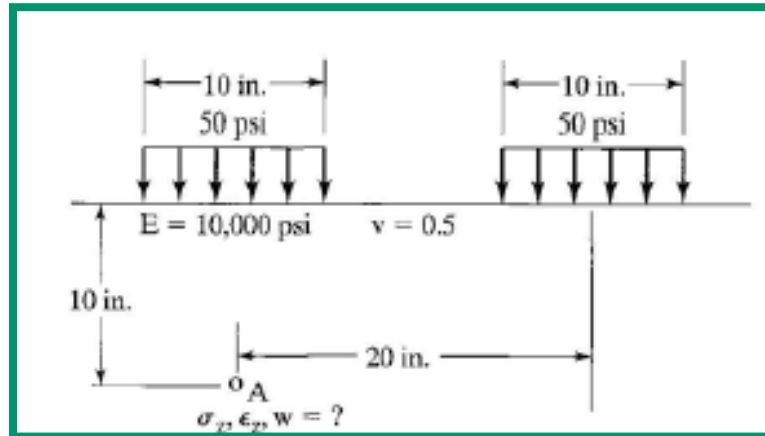

**Pavement Analysis and Design**

## Stresses and Strains in Flexible Pavements

### Single Layer Solutions at Axis of Symmetry

When the load is applied over a single circular loaded area, the most critical stress, strain and deflection occur under the center of the circular area on the axis of symmetry, where  $\tau_{rz} = 0$  and  $\sigma_r = \sigma_t$ , so  $\sigma_z$  and  $\sigma_r$  are the principal stresses.

The load applied from tyre to pavement is similar to a **flexible plate** with a radius  $a$  and a uniform pressure  $q$ . The stresses beneath the center of the plate can be determined from

$$\sigma_z = q \left[ 1 - \frac{z^3}{(a^2 + z^2)^{1.5}} \right]$$



## Stresses and Strains in Flexible Pavements

### Single Layer Solutions at Axis of Symmetry

$$\sigma_r = \frac{q}{2} \left[ 1 + 2\nu - \frac{2(1 + \nu)z}{(a^2 + z^2)^{0.5}} + \frac{z^3}{(a^2 + z^2)^{1.5}} \right]$$

$$\epsilon_z = \frac{(1 + \nu)q}{E} \left[ 1 - 2\nu + \frac{2\nu z}{(a^2 + z^2)^{0.5}} - \frac{z^3}{(a^2 + z^2)^{1.5}} \right]$$

$$\epsilon_r = \frac{(1 + \nu)q}{2E} \left[ 1 - 2\nu - \frac{2(1 - \nu)z}{(a^2 + z^2)^{0.5}} + \frac{z^3}{(a^2 + z^2)^{1.5}} \right]$$

# Stresses and Strains in Flexible Pavements

## Single Layer Solutions at Axis of Symmetry

$$w = \frac{(1 + \nu)qa}{E} \left\{ \frac{a}{(a^2 + z^2)^{0.5}} + \frac{1 - 2\nu}{a} \left[ (a^2 + z^2)^{0.5} - z \right] \right\}$$

When  $\nu = 0.5$

$$w = \frac{3qa^2}{2E(a^2 + z^2)^{0.5}}$$

When  $z = 0$

$$w_0 = \frac{2(1 - \nu^2)qa}{E}$$

# Stresses and Strains in Flexible Pavements

## Single Layer Solutions at Axis of Symmetry-Problem

For the loaded area shown, determine the stresses, strains, and deflection at point A.

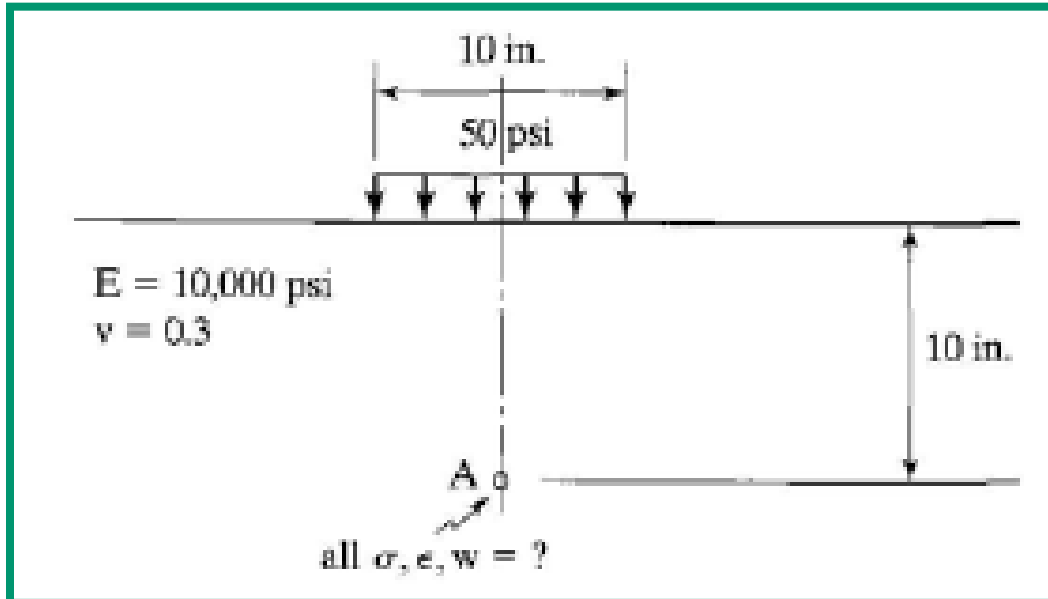

# Stresses and Strains in Flexible Pavements

## Single Layer Solutions at Axis of Symmetry-Rigid Plate

**So far all the analyses are based on the assumption that the load is applied on a flexible plate, such as a rubber tyre.**

**If the load is applied on a rigid plate, such as that used in a plate loading test, the deflection is the same at all points on the plate, but the pressure distribution under the plate is not uniform.**

**The differences between a flexible and a rigid plate are shown in Figure.**

# Stresses and Strains in Flexible Pavements

## Single Layer Solutions at Axis of Symmetry-Rigid Plate

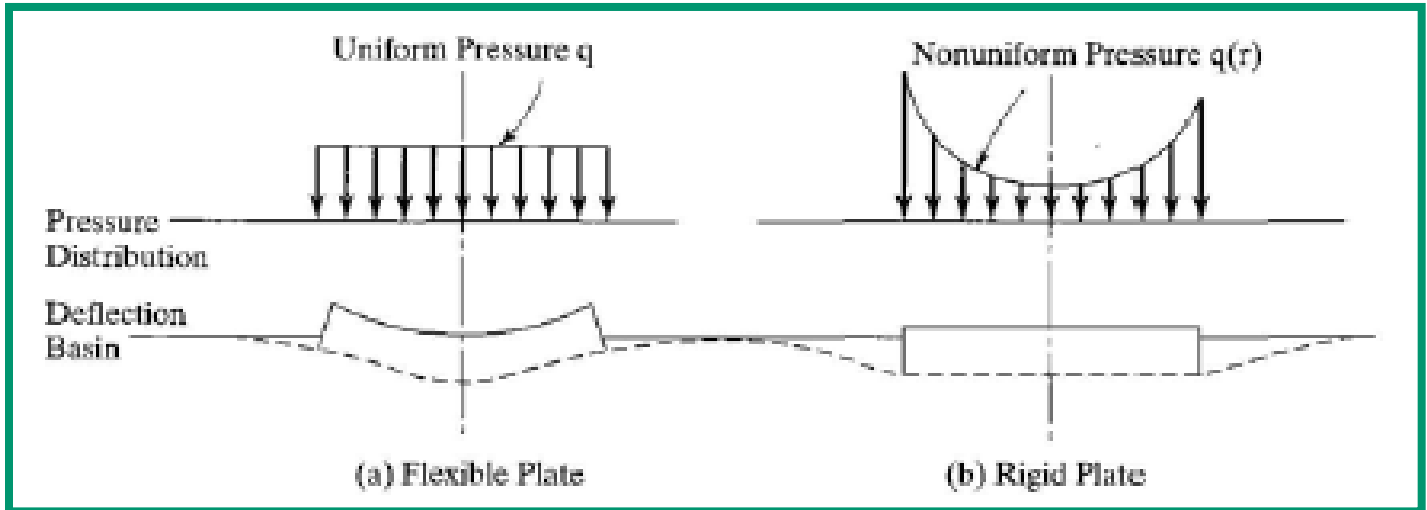

# Stresses and Strains in Flexible Pavements

## Single Layer Solutions at Axis of Symmetry-Rigid Plate

The pressure distribution under a rigid plate can be expressed as (Ullidtz, 1987):

$$q(r) = \frac{qa}{2(a^2 - r^2)^{0.5}}$$

in which  $r$  is the distance from center to the point where pressure is to be determined and  $q$  is the average pressure, which is equal to the total load divided by the area. The smallest pressure is at the center and equal to one-half of the average pressure. The pressure at the edge of the plate is infinity.

# Stresses and Strains in Flexible Pavements

## Single Layer Solutions at Axis of Symmetry-Rigid Plate

By integrating the point load over the area, it can be shown that the deflection of the rigid plate is:

$$w_0 = \frac{\pi(1 - \nu^2)qa}{2E}$$

# Stresses and Strains in Flexible Pavements

## Single Layer Solutions at Axis of Symmetry-Rigid Plate

**Surface deflection of the rigid plate is:**

$$w_0 = \frac{\pi(1 - \nu^2)qa}{2E}$$

**Surface deflection of the flexible plate is:**

$$w_0 = \frac{2(1 - \nu^2)qa}{E}$$

**A comparison of the above equations indicates that the surface deflection under a rigid plate is only 79% of that under the center of a uniformly distributed load.**

**This is reasonable because the pressure under the rigid plate is smaller near the center of the loaded area but greater near the edge.**



# Stresses and Strains in Flexible Pavements

## Single Layer Solutions at Axis of Symmetry-Rigid Plate-Problem

A plate loading test using a plate of 12-in. diameter was performed on the surface of the subgrade, as shown in Figure. A total load of 8000 lb was applied to the plate and a deflection of 0.1 in. was measured. Assuming that the subgrade has Poisson ratio 0.4, determine the elastic modulus of the subgrade.

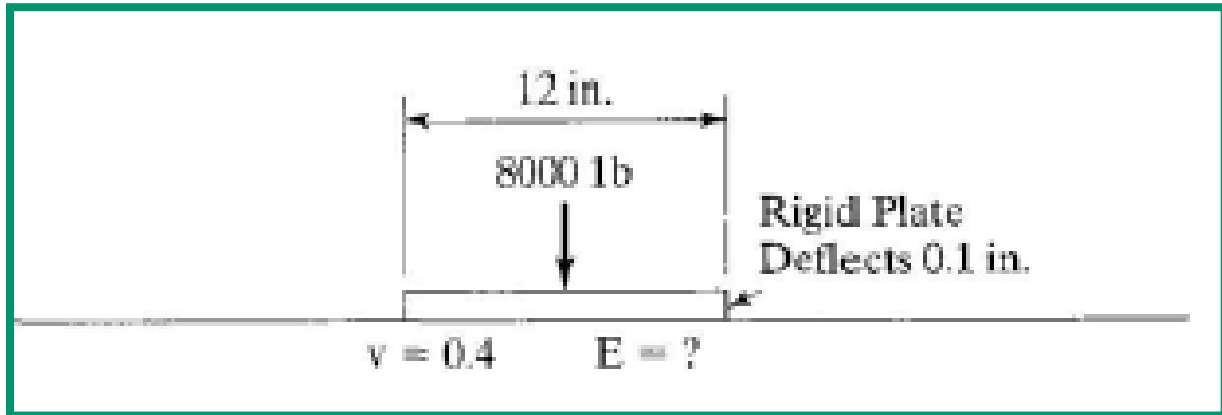

# Stresses and Strains in Flexible Pavements

## **LAYERED SYSTEMS**

**Flexible pavements are layered systems with better materials on top and cannot be represented by a homogeneous mass, so the use of Burmister's layered theory is more appropriate.**

**Burmister (1943) first developed solutions for a two-layer system and then extended them to a three-layer system (Burmister, 1945).**

**With the advent of computers, the theory can be applied to a multilayer system with any number of layers (Huang, 1967, 1968).**

# Stresses and Strains in Flexible Pavements

## LAYERED SYSTEMS

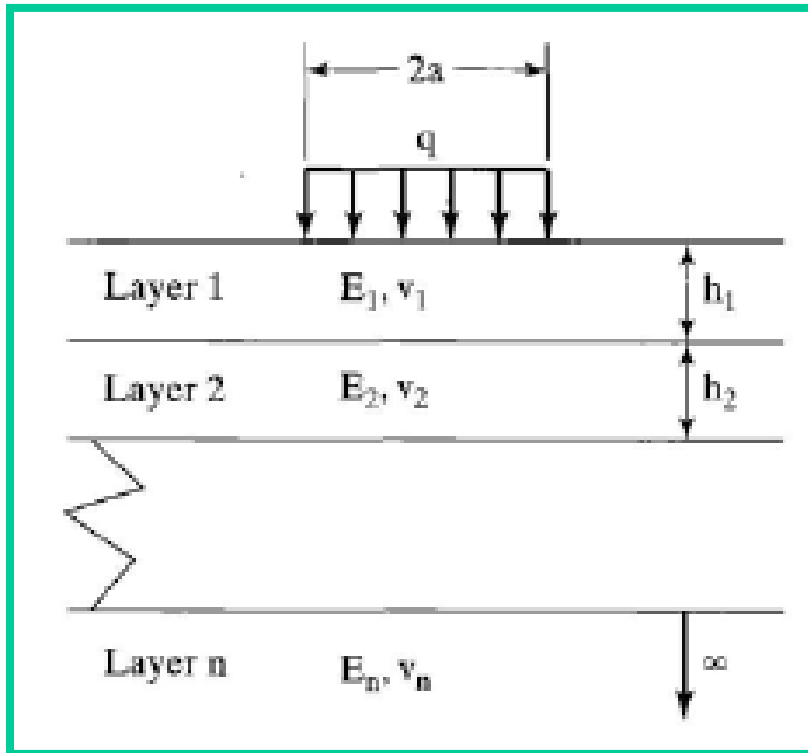

# Stresses and Strains in Flexible Pavements

## LAYERED SYSTEMS

Figure shows an  $n$ -layer system. The basic assumptions to be satisfied are:

1. Each layer is homogeneous, isotropic, and linearly elastic with an elastic modulus  $E$  and a Poisson ratio  $\nu$ .
2. The material is weightless and infinite in a real extent.
3. Each layer has a finite thickness  $h$ , except that the lowest layer is infinite in thickness.
4. A uniform pressure  $q$  is applied on the surface over a circular area of radius  $a$ .
5. Continuity conditions are satisfied at the layer interfaces, as indicated by the same vertical stress, shear stress, vertical displacement and radial displacement.

# Stresses and Strains in Flexible Pavements

## **LAYERED SYSTEMS**

**For frictionless interface, the continuity of shear stress and radial displacement is replaced by zero shear stress at each side of the interface.**

### **Two-Layer Systems**

**The exact case of a two-layer system is the full-depth construction in which a thick layer of HMA is placed directly on the subgrade.**

**If a pavement is composed of three layers (e .g ., an asphalt surface course, a granular base course, and a subgrade), it is necessary to combine the base course and the subgrade into a single layer for computing the stresses and strains in the asphalt layer or to combine the asphalt surface course and base course for computing the stresses and strains in the subgrade.**

# Stresses and Strains in Flexible Pavements

## **LAYERED SYSTEMS-Two-Layer Systems**

### **Vertical Stress**

**The vertical stress on the top of subgrade is an important factor in pavement design.**

**The function of a pavement is to reduce the vertical stress on the subgrade so that detrimental pavement deformations will not occur.**

**The allowable vertical stress on a given subgrade depends on the strength or modulus of the subgrade.**

**To combine the effect of stress and strength, the vertical compressive strain has been used most frequently as a design criterion.**

**This simplification is valid for highway and airport pavements because the vertical strain is caused primarily by the vertical stress and the effect of horizontal stress is relatively small.**

# Stresses and Strains in Flexible Pavements

## LAYERED SYSTEMS-Two-Layer Systems

### Vertical Stress

The design of railroad track beds should be based on vertical stress instead of vertical strain, because the large horizontal stress caused by the distribution of wheel loads through rails and ties over a large area makes the vertical strain a poor indicator of the vertical stress.

The stresses in a two-layer system depend on the modulus ratio  $E_1/E_2$  and the thickness-radius ratio  $h_1/a$ .

# Stresses and Strains in Flexible Pavements

## LAYERED SYSTEMS-Two-Layer Systems

### Vertical Stress distribution in a two layer system

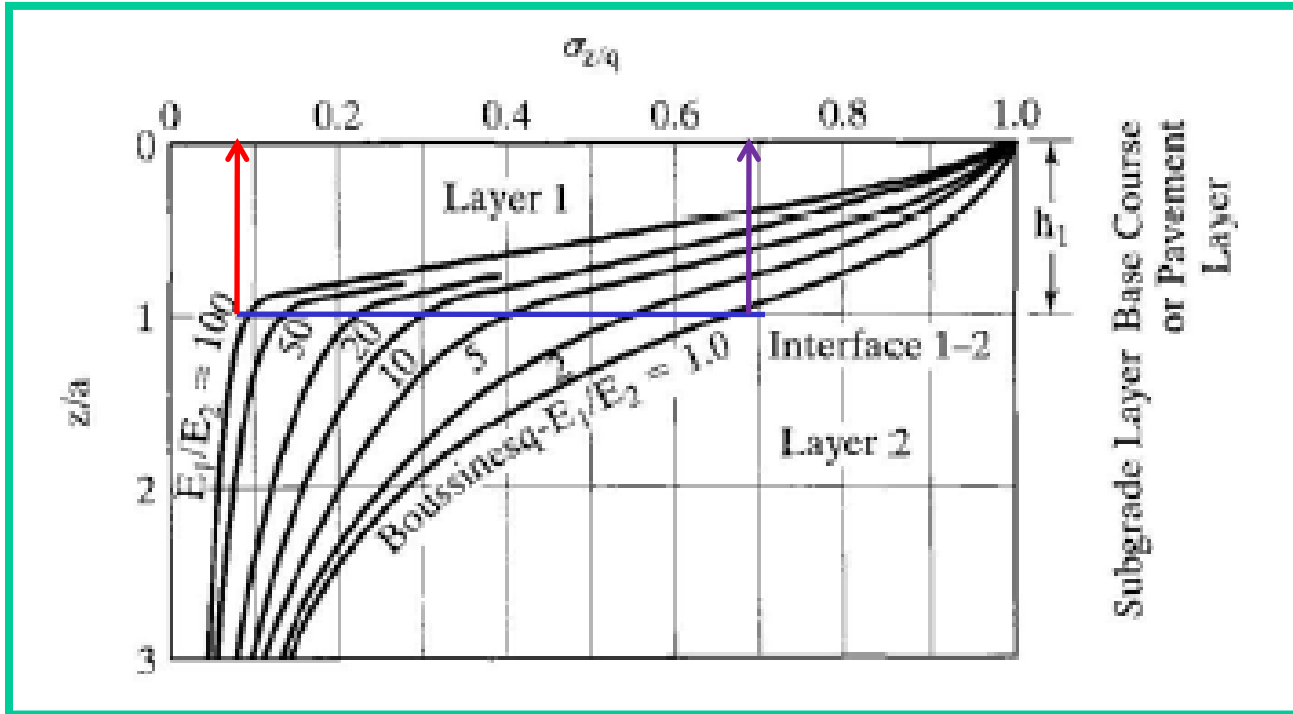



# Stresses and Strains in Flexible Pavements

## LAYERED SYSTEMS-Two-Layer Systems

### Vertical Stress

Figure shows the effect of a pavement layer on the distribution of vertical stresses under the center of a circular loaded area.

The chart is applicable to the case when the thickness  $h_1$  of layer 1 is equal to the radius of contact area or  $h_1/a=1$ .

For all charts presented in this section, a Poisson ratio of 0.5 is assumed for all layers.

It can be seen that the vertical stresses decrease significantly with the increase in modulus ratio.

## Stresses and Strains in Flexible Pavements

### LAYERED SYSTEMS-Two-Layer Systems

#### Vertical Stress

At the pavement-subgrade interface, the vertical stress is about **68%** of the applied pressure if  $E_1/E_2=1$ , as indicated by Boussinesq's stress distribution and reduces to about **8%** of the applied pressure if  $E_1/E_2=100$ .

# Stresses and Strains in Flexible Pavements

## LAYERED SYSTEMS-Two-Layer Systems

### Vertical interface stresses for two layer system

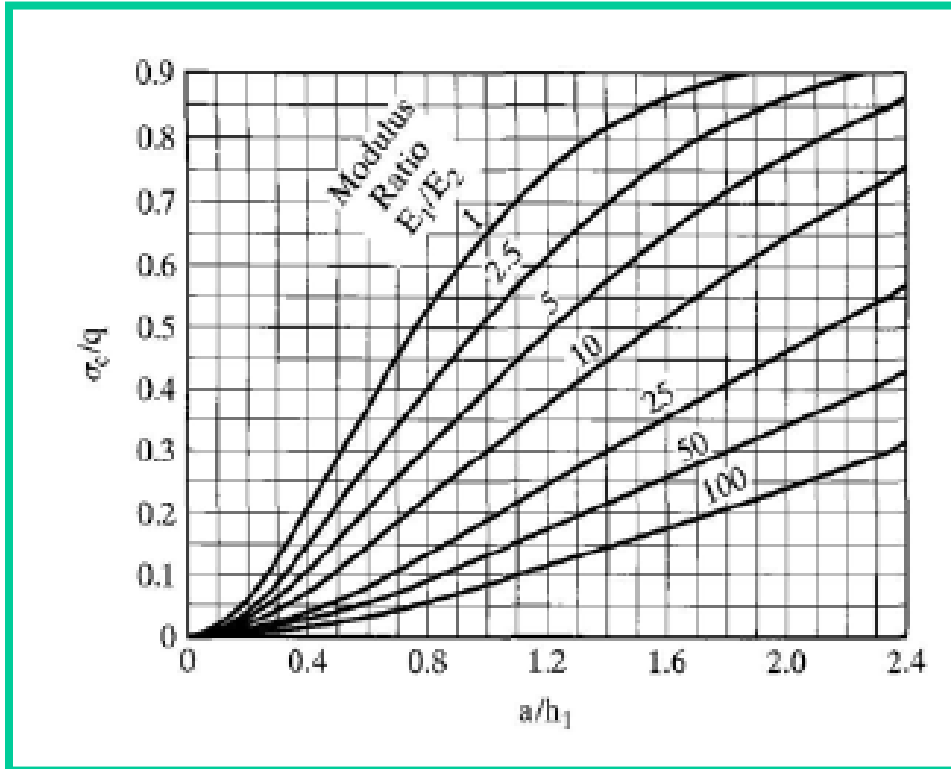

# Stresses and Strains in Flexible Pavements

## LAYERED SYSTEMS-Two-Layer Systems

### Vertical Stress

Figure shows the effect of pavement thickness and modulus ratio on the vertical stress  $\sigma_c$  at the pavement-subgrade interface under the center of a circular loaded area.

For a given applied pressure  $q$ , the vertical stress increases with the increase in contact radius and decreases with the increase in thickness.

The reason that the ratio  $a/h_1$  instead of  $h_1/a$  was used is for the purpose of preparing influence charts (Huang , 1969) for two-layer elastic foundations.

# Stresses and Strains in Flexible Pavements

## LAYERED SYSTEMS-Two-Layer Systems

### Vertical Stress-Numerical Problem

A circular load having radius 6 in. and uniform pressure 80 psi is applied on a two-layer system, as shown in Figure. The subgrade has elastic modulus 5000 psi and can support a maximum vertical stress of 8 psi. If the HMA has elastic modulus 500,000 psi, what is the required thickness of a full-depth pavement?

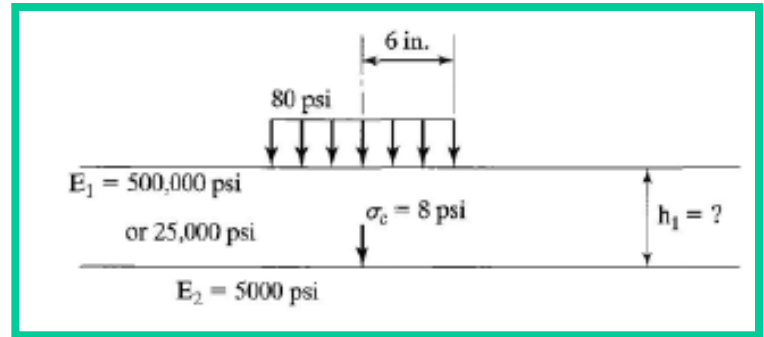

If a thin surface treatment is applied on a granular base with elastic modulus 25,000 psi, what is the thickness of base course required?

# Stresses and Strains in Flexible Pavements

## LAYERED SYSTEMS-Two-Layer Systems

### Vertical Stress-Numerical Problem

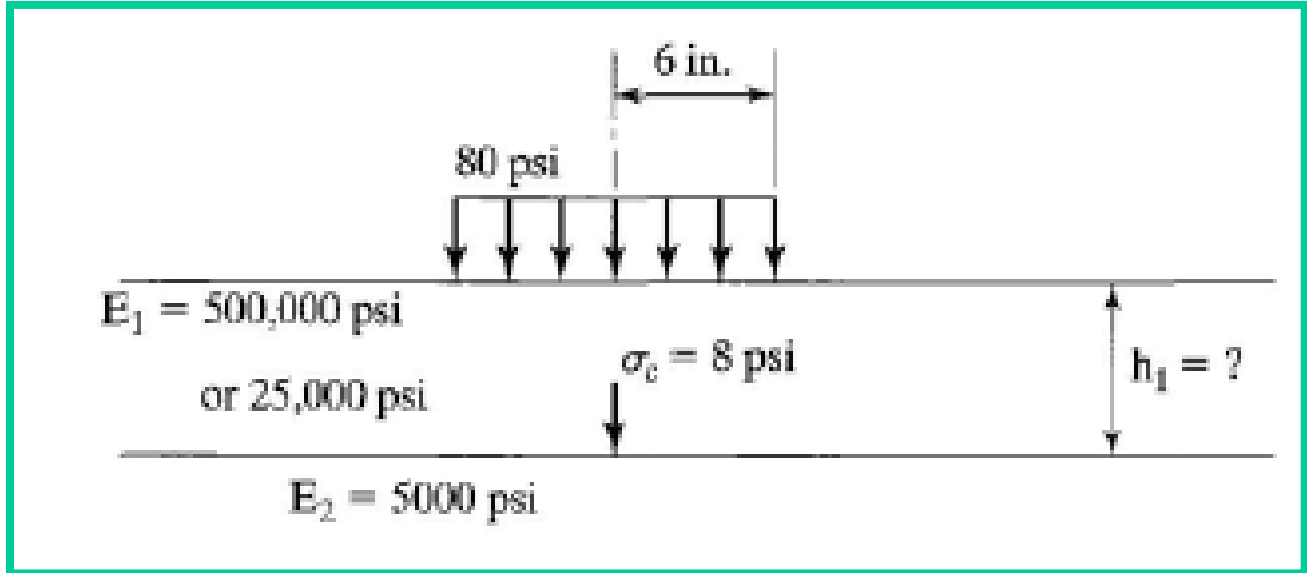

# Stresses and Strains in Flexible Pavements

## LAYERED SYSTEMS-Two-Layer Systems

### Vertical Stress-Numerical Problem

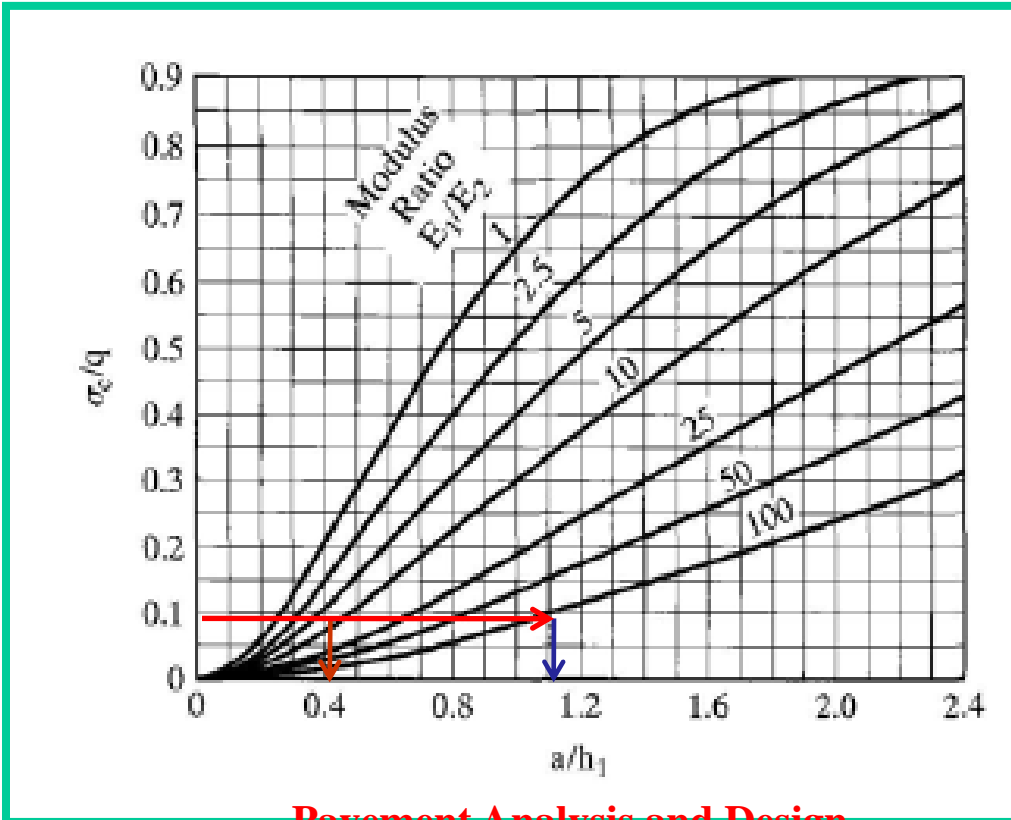

**LAYERED SYSTEMS-Two-Layer Systems**

**Vertical Stress-Numerical Problem**

**In this example, an allowable vertical stress of 8 psi is arbitrarily selected to show the effect of the modulus of the reinforced layer on the thickness required. The allowable vertical stress should depend on the number of load repetitions.**



# Stresses and Strains in Flexible Pavements

## LAYERED SYSTEMS-Two-Layer Systems

### Vertical Stress

Using the Shell design criterion and the AASHTO equation, Huang et al. (1984b) developed the relationship

$$N_d = 4.873 \times 10^{-5} \sigma_c^{-3.734} E_2^{3.583}$$

in which  $N_d$  is the allowable number of stress repetitions to limit permanent deformation,  $\sigma_c$  is the vertical compressive stress on the surface of the subgrade in psi, and  $E_2$  is the elastic modulus of the subgrade in psi.

For a stress of 8 psi and an elastic modulus of 5000 psi, the allowable number of repetitions is  $3.7 \times 10^5$ .

# Stresses and Strains in Flexible Pavements

## LAYERED SYSTEMS-Two-Layer Systems

### Vertical Surface Deflection for two layer system

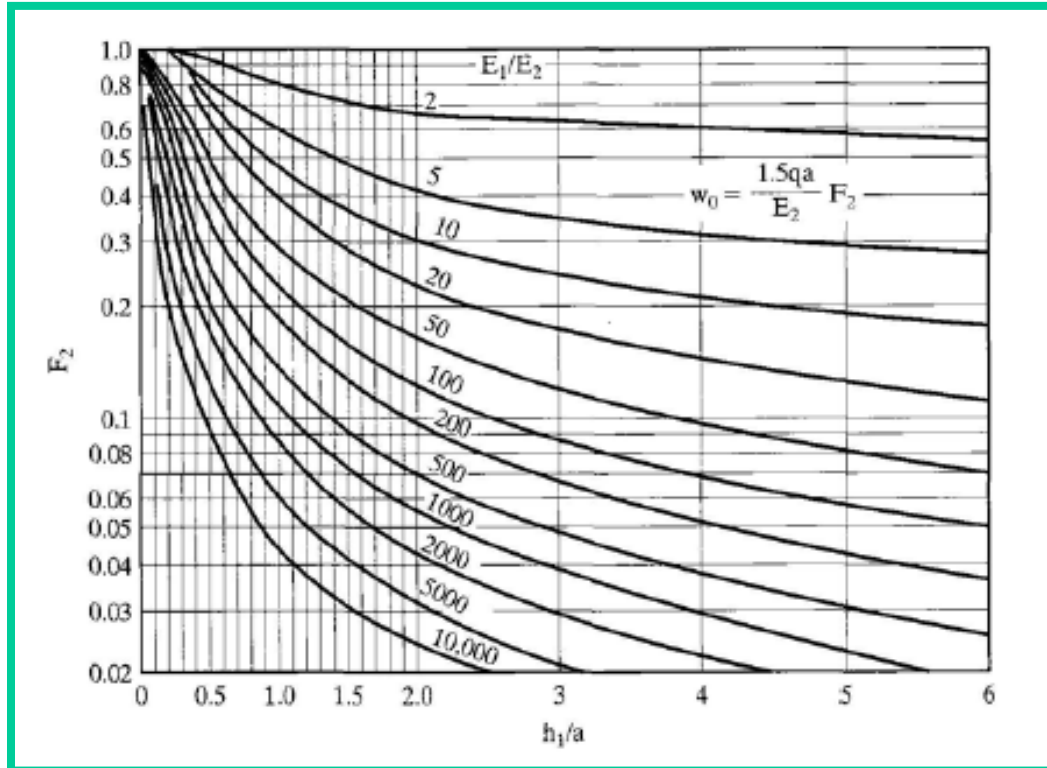

## Stresses and Strains in Flexible Pavements

### LAYERED SYSTEMS-Two-Layer Systems

#### Vertical Surface Deflection

Vertical surface deflections have been used as a criterion of pavement design. Figure can be used to determine the surface deflections for two-layer systems. The deflection is expressed in terms of the deflection factor  $F_2$  by

$$w_0 = \frac{1.5qa}{E_2} F_2$$

# Stresses and Strains in Flexible Pavements

## LAYERED SYSTEMS-Two-Layer Systems

### Vertical Surface Deflection

$$w_0 = \frac{1.5qa}{E_2} F_2$$

The deflection factor is a function of  $E_1/E_2$  and  $h_1/a$ . For a homogeneous half-space with  $h_1/a=0$ ,  $F_2=1$ .

If the load is applied by a rigid plate then,

$$w_0 = \frac{1.18qa}{E_2} F_2$$

# Stresses and Strains in Flexible Pavements

## LAYERED SYSTEMS-Two-Layer Systems

### Vertical Surface Deflection-Numerical Problem

A total load of 20,000 lb was applied on the surface of a two-layer system through a rigid plate 12 in. in diameter, as shown in Figure. Layer 1 has a thickness of 8 in. and layer 2 has an elastic modulus of 6400 psi. Both layers are incompressible with a Poisson ratio of 0.5. If the deflection of the plate is 0.1 in., determine the elastic modulus of layer 1.

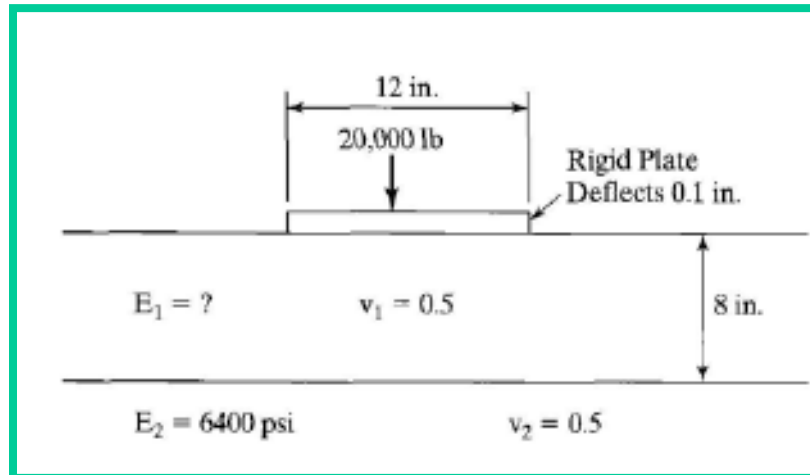

# Stresses and Strains in Flexible Pavements

## LAYERED SYSTEMS-Two-Layer Systems

### Vertical Surface Deflection-Numerical Problem

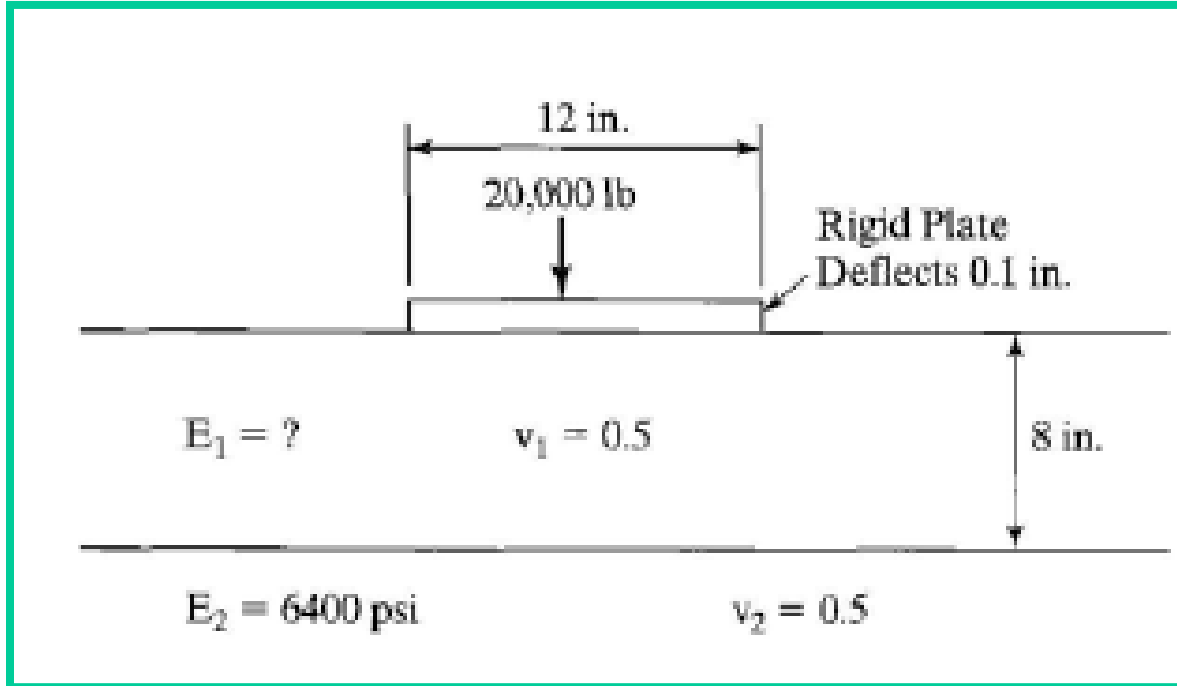

# Stresses and Strains in Flexible Pavements

## LAYERED SYSTEMS-Two-Layer Systems

### Vertical Surface Deflection-Numerical Problem

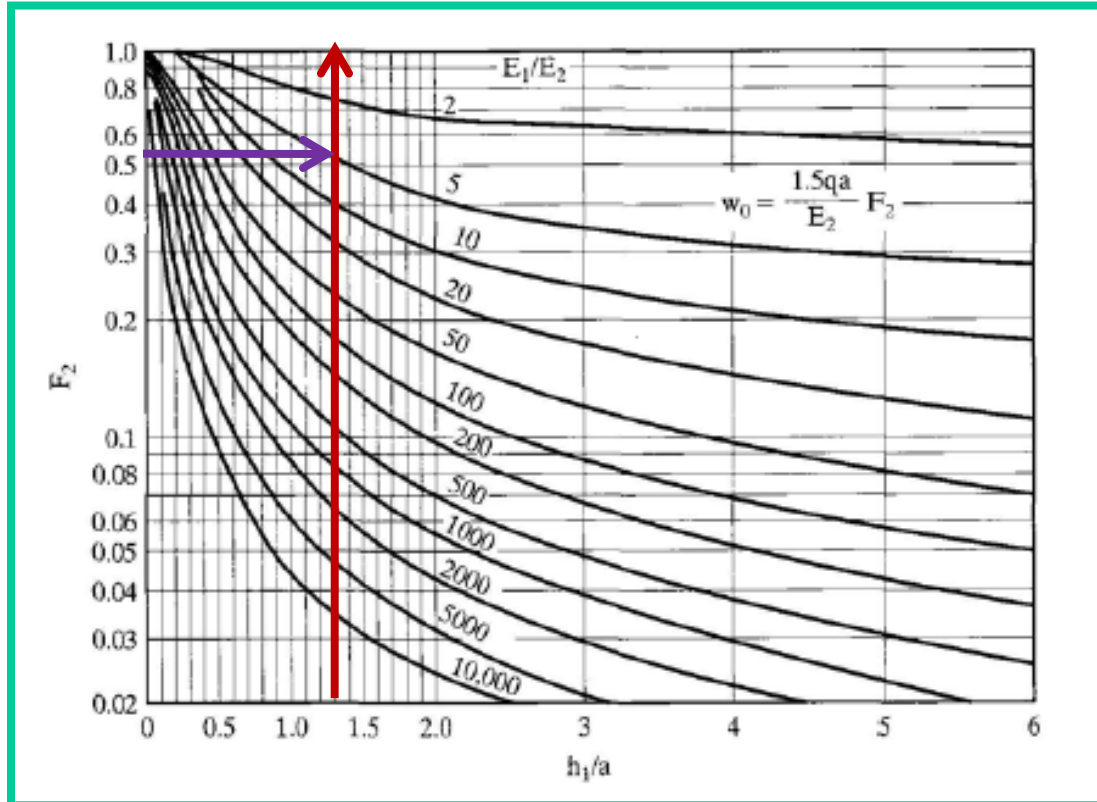

**Pavement Analysis and Design**

# Stresses and Strains in Flexible Pavements

## LAYERED SYSTEMS-Two-Layer Systems

### Vertical Interface Deflection

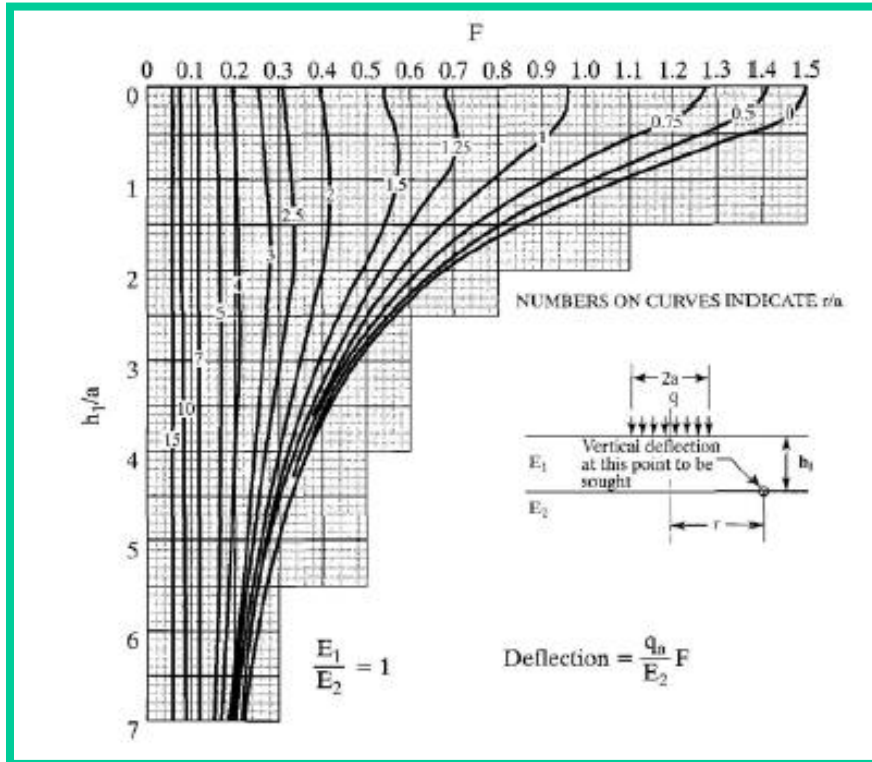



# Stresses and Strains in Flexible Pavements

## LAYERED SYSTEMS-Two-Layer Systems

### Vertical Interface Deflection

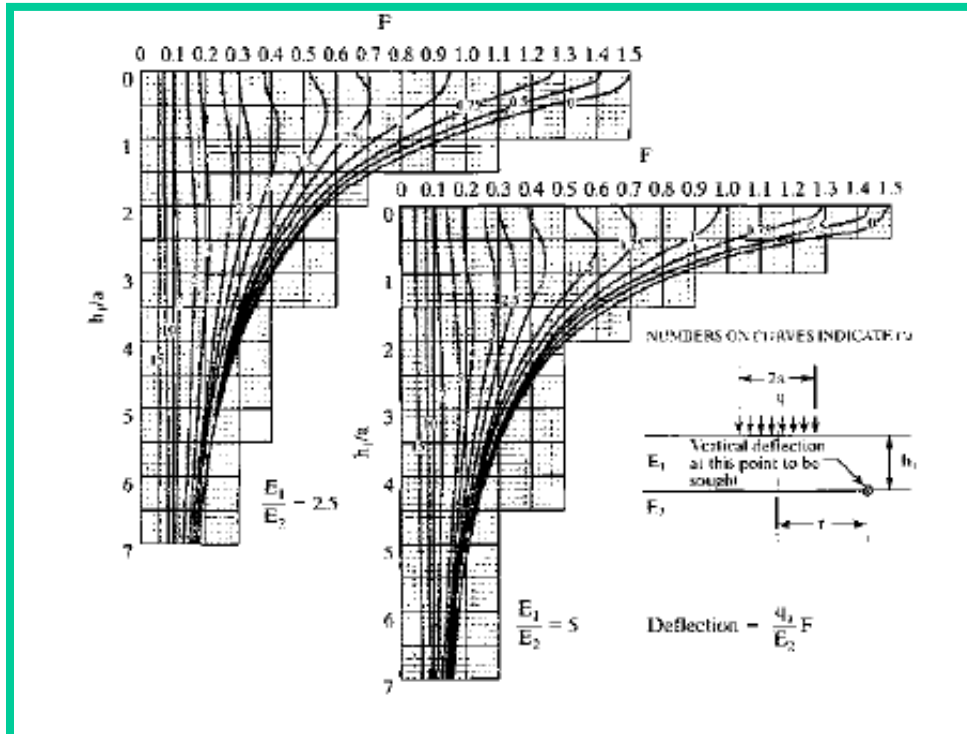

# Stresses and Strains in Flexible Pavements

## LAYERED SYSTEMS-Two-Layer Systems

### Vertical Interface Deflection

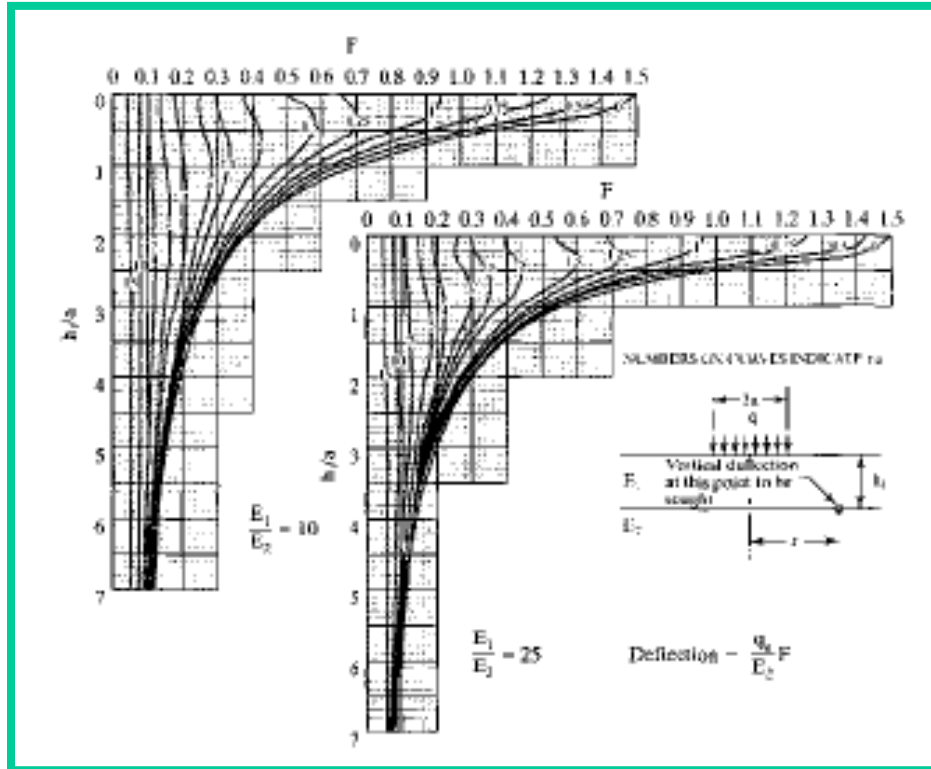

### Pavement Analysis and Design

# Stresses and Strains in Flexible Pavements

## LAYERED SYSTEMS-Two-Layer Systems

### Vertical Interface Deflection

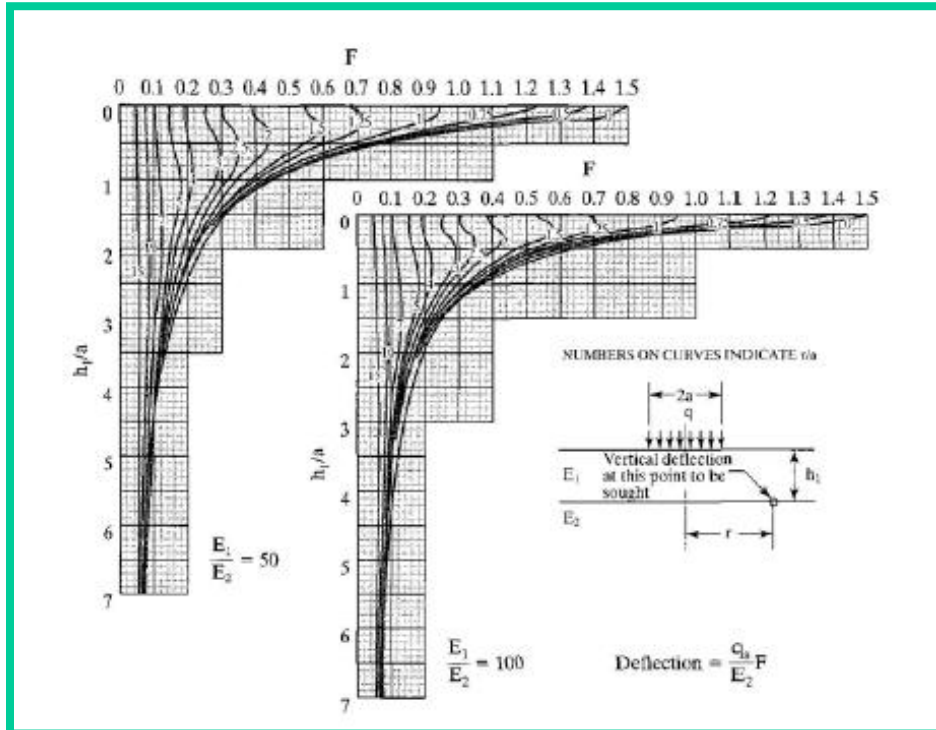

# Stresses and Strains in Flexible Pavements

## LAYERED SYSTEMS-Two-Layer Systems

### Vertical Interface Deflection

The vertical interface deflection has also been used as a design criterion.

Figure 2.19 can be used to determine the vertical interface deflection in a two-layer system (Huang, 1969c).

The deflection is expressed in terms of the deflection factor  $F$  by

$$w = \frac{qa}{E_2} F$$

## Stresses and Strains in Flexible Pavements

### LAYERED SYSTEMS-Two-Layer Systems

#### Vertical Interface Deflection

Note that  $F$  in the above equation is different from  $F_2$  in equation for vertical surface deflection by the factor 1.5.

The deflection factor is a function of  $E_1/E_2$ ,  $h_1/a$ , and  $r/a$ , where  $r$  is the radial distance from the center of loaded area.

Seven sets of charts for the modulus ratios 1, 2.5, 5, 10, 25, 50 and 100 are shown; the deflection for any intermediate modulus ratio can be obtained by interpolation. The case of  $E_1/E_2=1$  is Boussinesq's solution.

# Stresses and Strains in Flexible Pavements

## LAYERED SYSTEMS-Two-Layer Systems

### Vertical Interface Deflection-Numerical Problem

Figure shows a set of dual tyres, each having contact radius 4.52 in. and contact pressure 70 psi. The center-to-center spacing of the dual is 13.5 in. Layer 1 has thickness 6 in. and elastic modulus 100,000 psi; layer 2 has elastic modulus 10,000 psi. Determine the vertical deflection at point A, which is on the interface beneath the center of one loaded area.

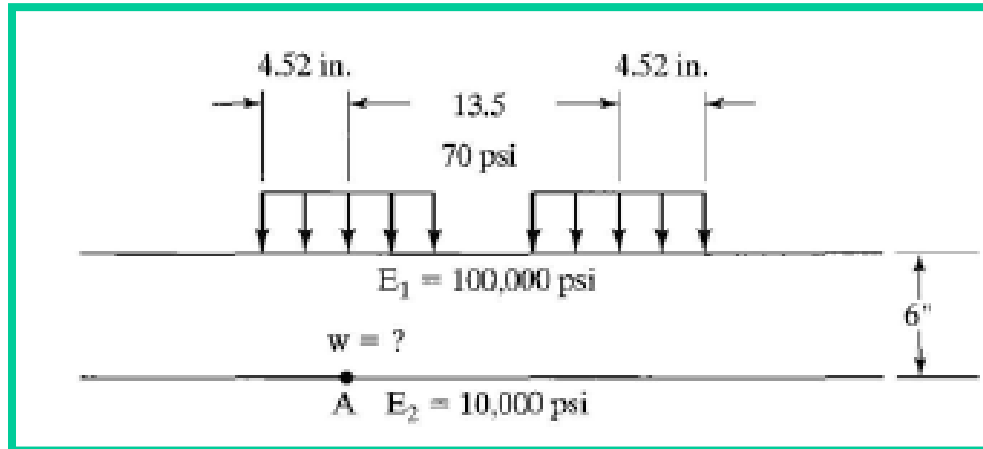

# Stresses and Strains in Flexible Pavements

## LAYERED SYSTEMS-Two-Layer Systems

### Vertical Interface Deflection-Numerical Problem

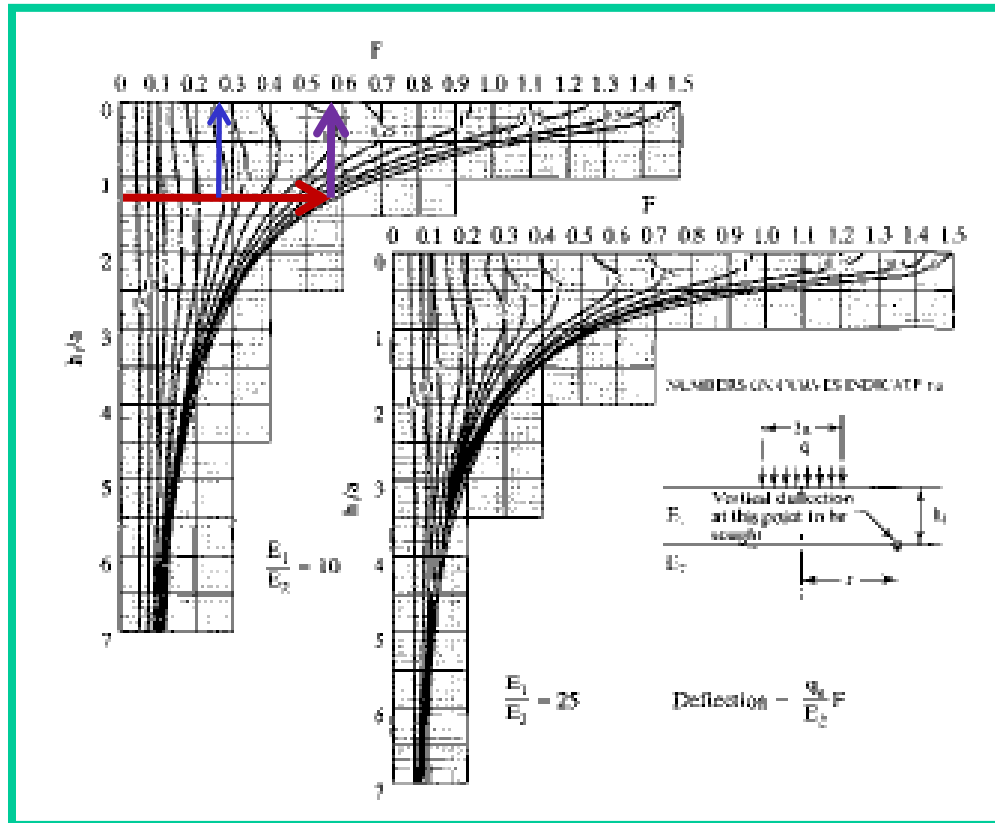

## Pavement Analysis and Design

# Stresses and Strains in Flexible Pavements

## LAYERED SYSTEMS-Two-Layer Systems

### Vertical Interface Deflection

The maximum interface deflection under dual tyres might not occur at point A. To determine the maximum interface deflection, it is necessary to compute the deflection at several points, say one under the center of one tyre, one at the center between two tyres and the other under the edge of one tyre and find out which is maximum.



## Stresses and Strains in Flexible Pavements

### **LAYERED SYSTEMS-Two-Layer Systems**

#### **Critical Tensile Strain**

**The tensile strains at the bottom of asphalt layer have been used as a design criterion to prevent fatigue cracking.**

**Two types of principal strains could be considered. One is the overall principal strain based on all six components of normal and shear stresses. The other is the horizontal principal strain based on the horizontal normal and shear stresses only.**

**The overall principal strain is slightly greater than the horizontal principal strain, so the use of overall principal strain is on the safe side.**

# Stresses and Strains in Flexible Pavements

## LAYERED SYSTEMS-Two-Layer Systems

### Critical Tensile Strain

Huang developed charts for determining the critical tensile strain at the bottom of layer 1 for a two-layered system. The critical tensile strain is the overall strain and can be determined from:

$$e = \frac{q}{E_1} F_e$$

in which  $e$  is the critical tensile strain and  $F_e$  is the strain factor, which can be determined from the charts.

# Stresses and Strains in Flexible Pavements

## LAYERED SYSTEMS-Two-Layer Systems

### Critical Tensile Strain-Single Wheel

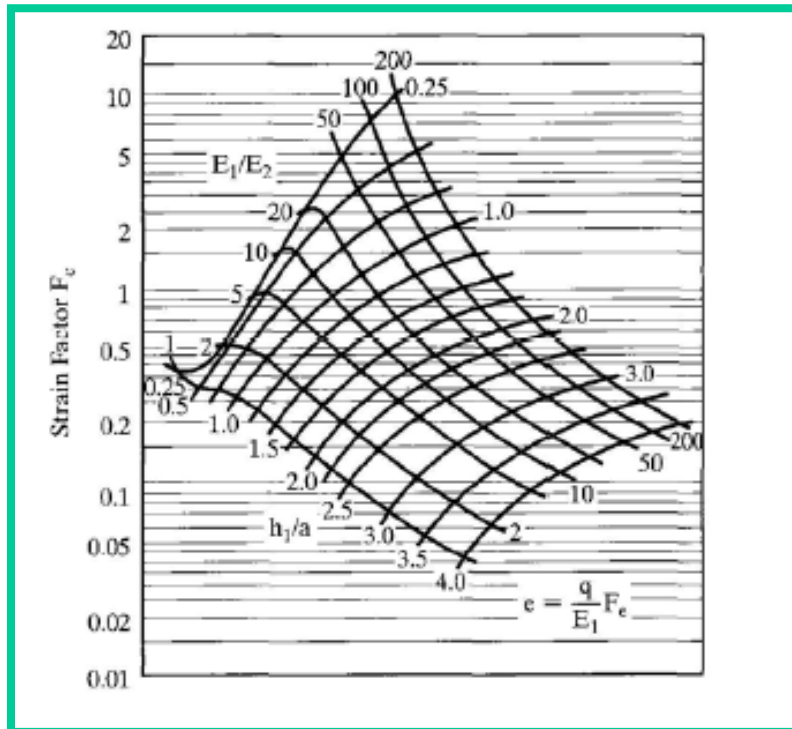

## Stresses and Strains in Flexible Pavements

### LAYERED SYSTEMS-Two-Layer Systems

#### Critical Tensile Strain-Single Wheel

Figure presents the strain factor for a two-layer system under a circular loaded area. In most cases, the critical tensile strain occurs under the center of the loaded area, where the shear stress is zero.

However, when both  $h_1/a$  and  $E_1/E_2$  are small, the critical tensile strain occurs at some distance from the center, as the predominant effect of the shear stress.

Under such situations, the principal tensile strains at the radial distances  $0$ ,  $0.5a$ ,  $a$  and  $1.5a$  from the center were computed and the critical value was obtained and plotted in Figure.

# Stresses and Strains in Flexible Pavements

## LAYERED SYSTEMS-Two-Layer Systems

### Critical Tensile Strain-Single Wheel-Numerical Problem

Figure shows a full-depth asphalt pavement 8 in. thick subjected to a single-wheel load of 9,000 lb having contact pressure 67.7 psi. If the elastic modulus of the asphalt layer is 150,000 psi and that of the subgrade is 15,000 psi, determine the critical tensile strain in the asphalt layer.

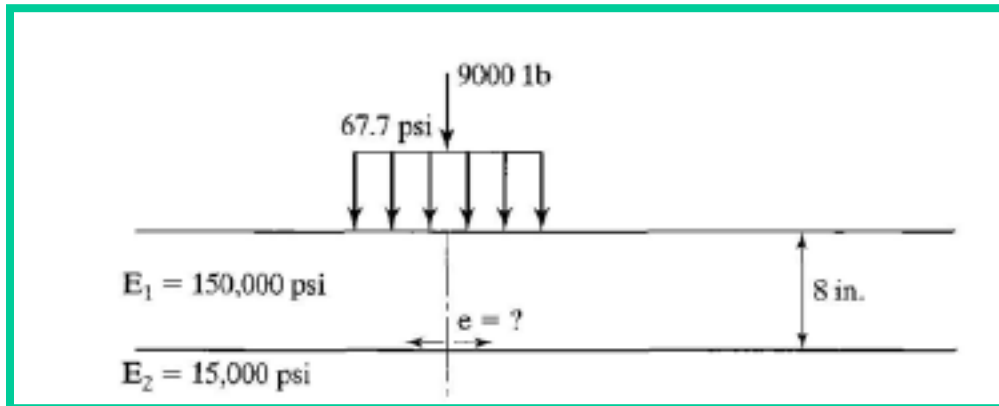

# Stresses and Strains in Flexible Pavements

## LAYERED SYSTEMS-Two-Layer Systems

### Critical Tensile Strain-Single Wheel-Numerical Problem

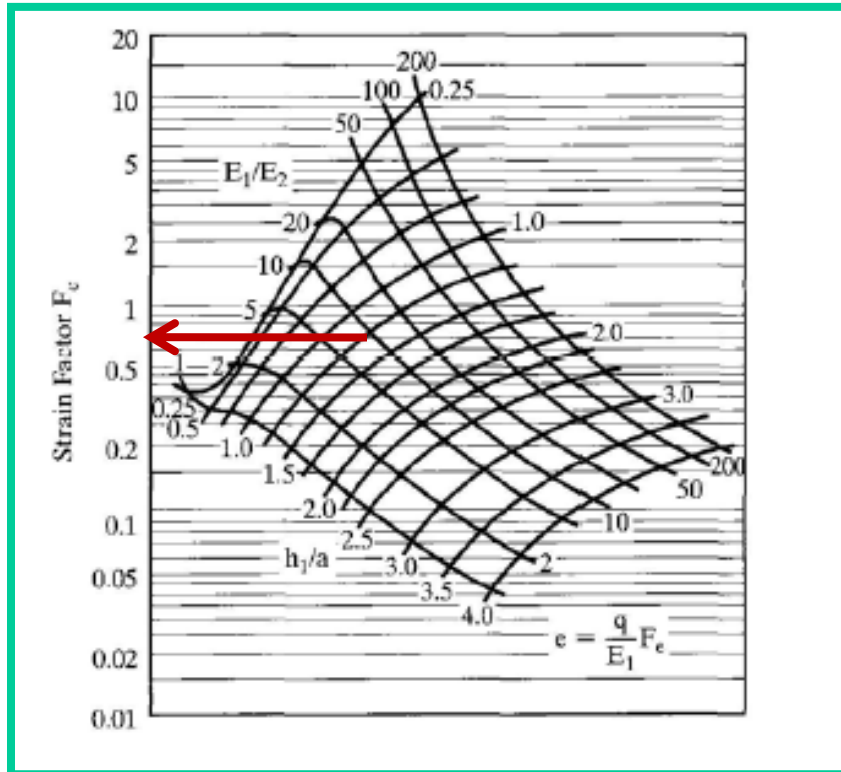

# Stresses and Strains in Flexible Pavements

## **LAYERED SYSTEMS-Two-Layer Systems**

### **Critical Tensile Strain-Single Wheel**

**It is interesting to note that the bonded interface makes the horizontal tensile strain at the bottom of layer 1 equal to the horizontal tensile strain at the top of layer 2.**

**If layer 2 is incompressible and the critical tensile strain occurs on the axis of symmetry, then the vertical compressive strain is equal to twice the horizontal strain.**

# Stresses and Strains in Flexible Pavements

## LAYERED SYSTEMS-Two-Layer Systems

### Critical Tensile Strain-Dual Wheels

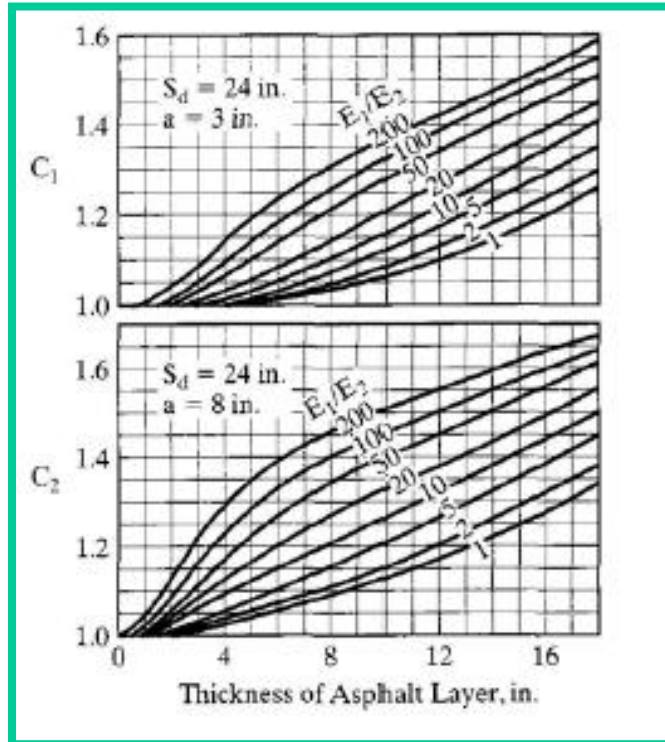



## Stresses and Strains in Flexible Pavements

### LAYERED SYSTEMS-Two-Layer Systems

#### Critical Tensile Strain-Dual Wheels

Because the strain factor for dual wheels with a contact radius  $a$  and a dual spacing  $S_d$  depends on  $S_d/a$  in addition to  $E_1/E_2$  and  $h_1/a$ , the most direct method is to present charts similar to single wheel analysis, one for each value of  $S_d/a$ .

However, this approach requires a series of charts, and the interpolation could be quite time-consuming. To avoid these difficulties, a unique method was developed that requires only one chart, as shown in Figure.

## Stresses and Strains in Flexible Pavements

### **LAYERED SYSTEMS-Two-Layer Systems**

#### **Critical Tensile Strain-Dual Wheels**

**In this method, the dual wheels are replaced by a single wheel with the same contact radius  $a$ , so that chart developed for single wheel analysis can still be used.**

**Because the strain factor for dual wheels is generally greater than that for a single wheel, a conversion factor  $C$ , which is the ratio between dual and single-wheel strain factors, must be determined. Multiplication of the conversion factor by the strain factor obtained from chart for single wheel analysis will yield the strain factor for dual wheels.**

# Stresses and Strains in Flexible Pavements

## LAYERED SYSTEMS-Two-Layer Systems

### Critical Tensile Strain-Dual Wheels

The procedure can be summarized as follows :

1. From the given  $S_d$ ,  $h_1$  and  $a$ , determine the modified radius  $a'$  and the modified thickness  $h'_1$ :

$$a' = \frac{24}{S_d} a$$

$$h'_1 = \frac{24}{S_d} h_1$$

2. Using  $h'_1$  as the pavement thickness, find conversion factors  $C_1$  and  $C_2$  from the figure.

3. Determine the conversion factor for  $a'$  by a straight-line interpolation between 3 and 8 in. or

$$C = C_1 + 0.2 (a' - 3)(C_2 - C_1)$$

**Pavement Analysis and Design**

# Stresses and Strains in Flexible Pavements

## LAYERED SYSTEMS-Two-Layer Systems

### Critical Tensile Strain-Dual Wheels-Numerical Problem

For the pavement shown in figure, the 9,000-lb load is applied over a set of dual tyres with a center-to-center spacing of 11.5 in. and a contact pressure of 67.7 psi, determine the critical tensile strain in the asphalt layer.

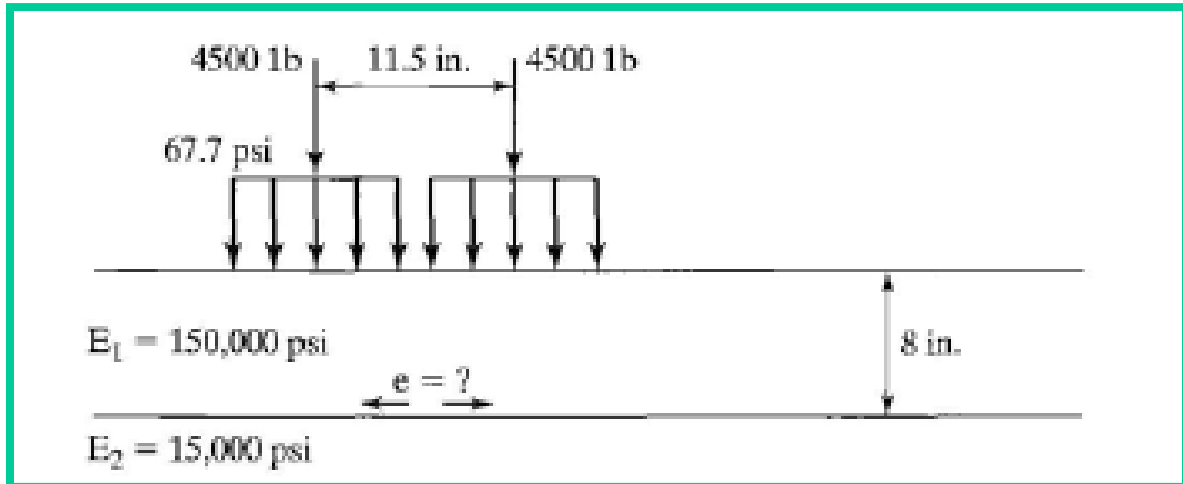

# Stresses and Strains in Flexible Pavements

## LAYERED SYSTEMS-Two-Layer Systems

### Critical Tensile Strain-Dual Wheels-Problem

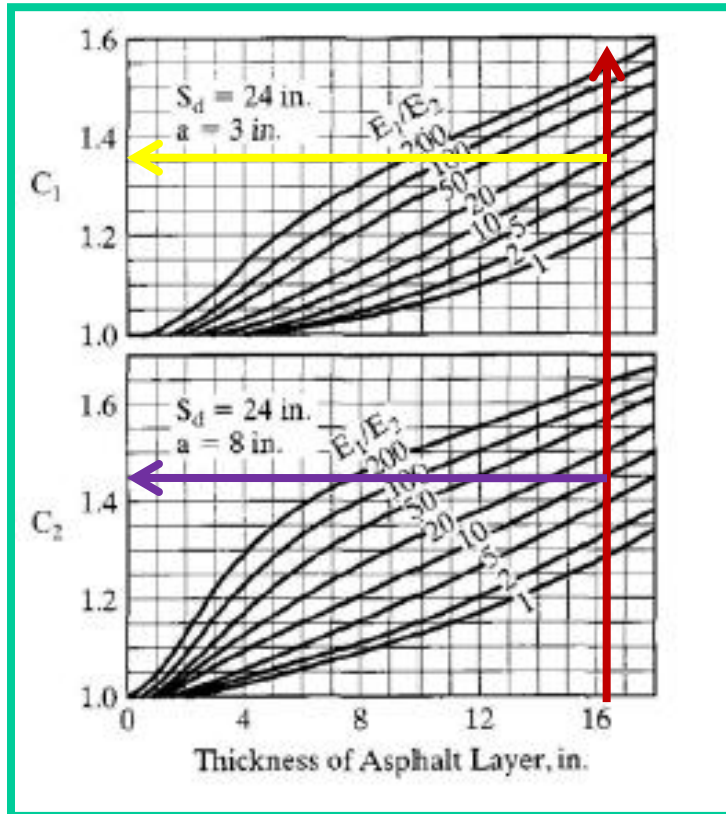

# Stresses and Strains in Flexible Pavements

## LAYERED SYSTEMS-Two-Layer Systems

### Critical Tensile Strain-Dual Wheels-Problem

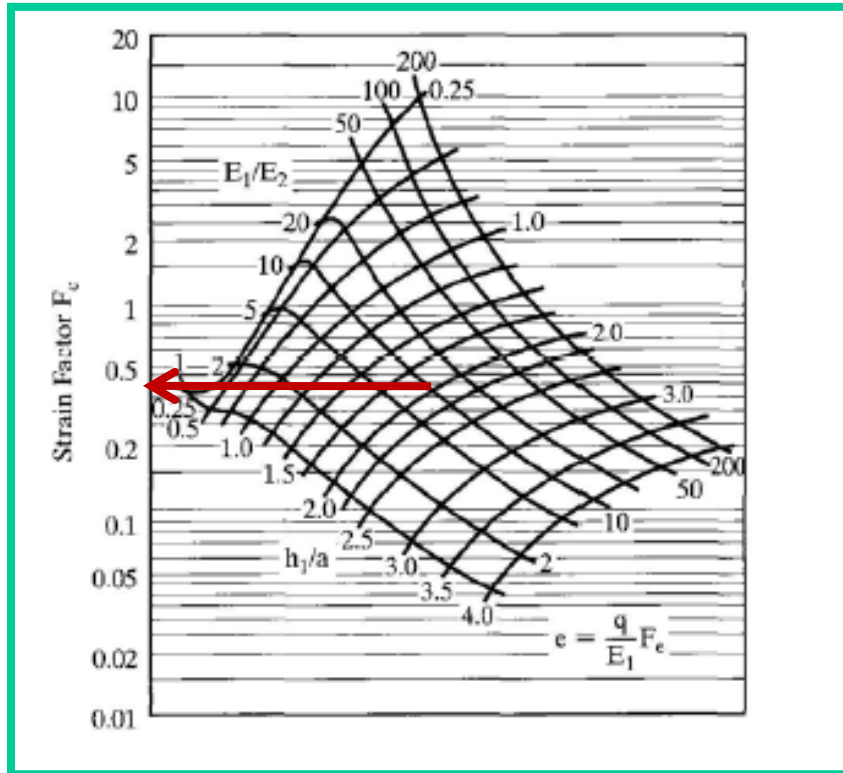

# Stresses and Strains in Flexible Pavements

## LAYERED SYSTEMS-Two-Layer Systems

### Critical Tensile Strain-Dual Tandem Wheels

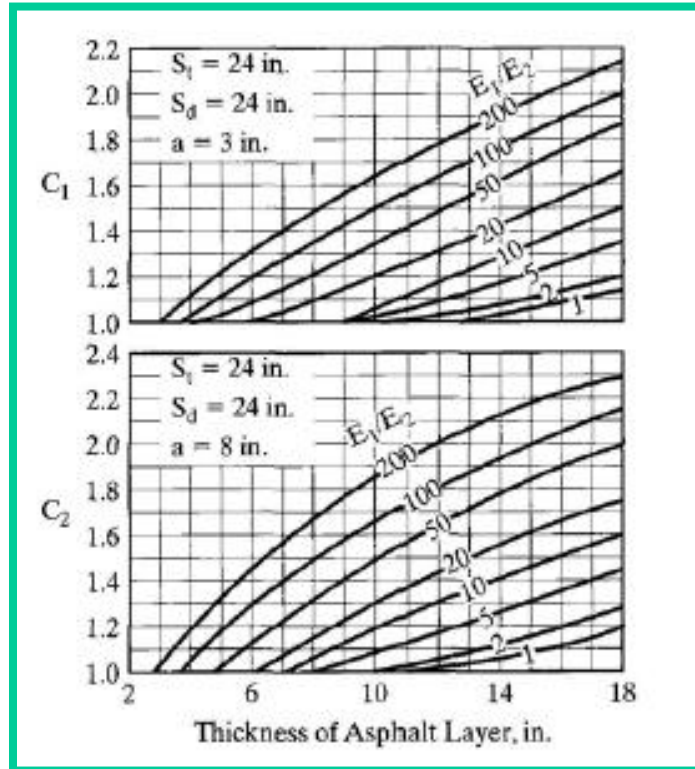

## Pavement Analysis and Design

# Stresses and Strains in Flexible Pavements

## LAYERED SYSTEMS-Two-Layer Systems

### Critical Tensile Strain-Dual Tandem Wheels

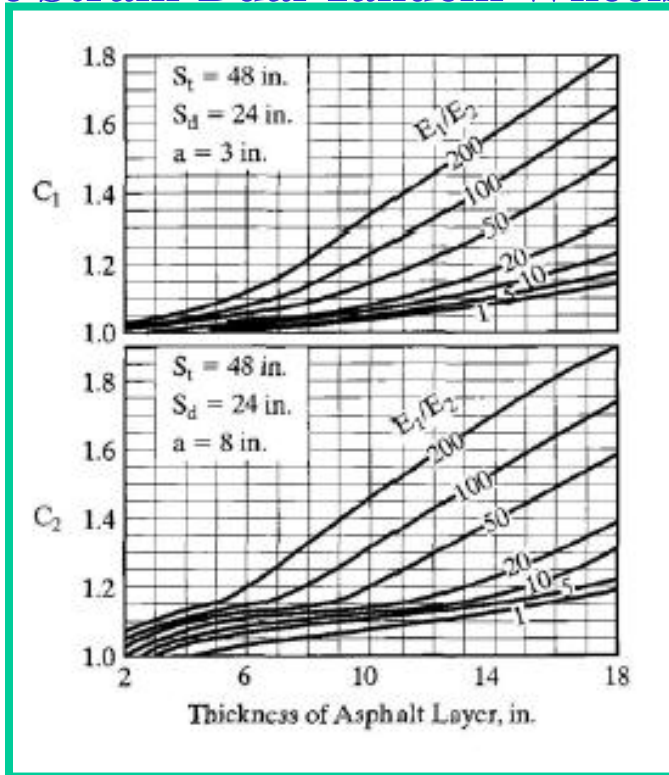



# Stresses and Strains in Flexible Pavements

## LAYERED SYSTEMS-Two-Layer Systems

### Critical Tensile Strain-Dual Tandem Wheels

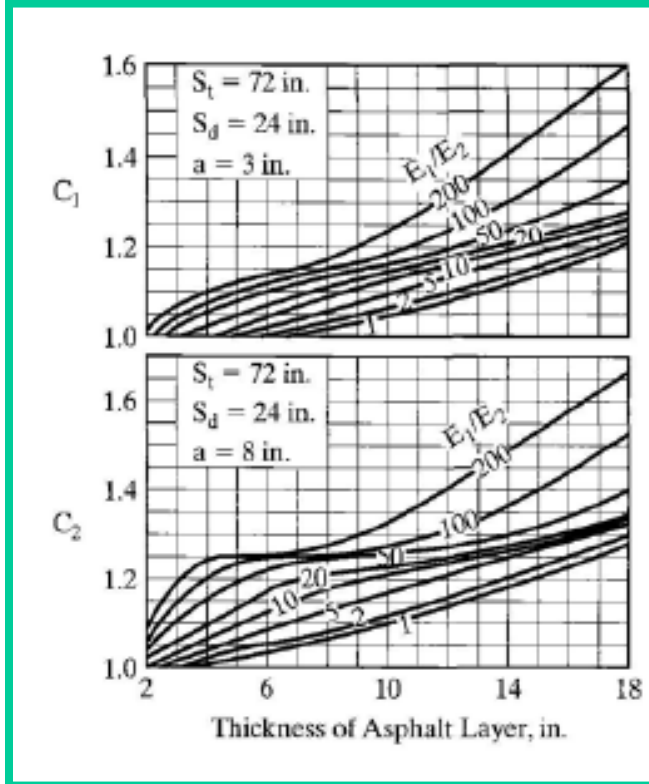

## Stresses and Strains in Flexible Pavements

### **LAYERED SYSTEMS-Two-Layer Systems**

#### **Critical Tensile Strain-Dual Tandem Wheels**

Charts similar to dual wheel analysis with dual spacing  $S_d$  of 24 in. and tandem spacings  $S_t$  of 24 in., 48 in. and 72 in. were developed for determining the conversion factor due to dual-tandem wheels as shown in Figures. The use of these charts is similar to the that for dual wheels.

Because the conversion factor for dual-tandem wheels depends on  $h_1/a$ ,  $S_d/a$  and  $S_t/a$  and because the actual  $S_d$  may not be equal to 24 in., it is necessary to change  $S_d$  to 24 in. and then modify the contact radius  $a$ , thus keeping the ratio  $S_d/a$  unchanged.

# Stresses and Strains in Flexible Pavements

## LAYERED SYSTEMS-Two-Layer Systems

### Critical Tensile Strain-Dual Tandem Wheels

The values of  $h_1$  and  $S_t$  must also be changed accordingly to keep  $h_1/a$  and  $S_d/a$  unchanged. Therefore, the original problem is changed to a new problem with  $S_d=24$  in. and a new  $S_t$ .

The conversion factor for  $S_t = 24, 48, \text{ and } 72$  in. can be obtained from the charts; that for other values of  $S_t$  can be determined by interpolation.

## Stresses and Strains in Flexible Pavements

### **LAYERED SYSTEMS-Two-Layer Systems**

#### **Critical Tensile Strain-Dual Tandem Wheels**

**If the new values of  $S_t$  are greater than 72 in., chart for dual wheels analysis can be used for interpolation. In fact, this chart is a special case of dual-tandem wheels when the tandem spacing approaches infinity.**

**It was found that, when  $S_t = 120$  in. the conversion factor due to dual-tandem wheels does not differ significantly from that due to dual wheels alone, so this chart can be considered to have a tandem spacing of 120 in.**

## Stresses and Strains in Flexible Pavements

### **LAYERED SYSTEMS-Two-Layer Systems**

#### **Critical Tensile Strain-Dual Tandem Wheels**

**A comparison of chart for dual wheels analysis with charts for dual-tandem wheels clearly indicates that, in many cases, the addition of tandem wheels reduces the conversion factor, thus decreasing the critical tensile strain. This is due to the compensative effect caused by the additional wheels.**

**The interaction among these wheels is quite unpredictable, as indicated by the irregular shape of the curves in the lower part of charts.**

# Stresses and Strains in Flexible Pavements

## LAYERED SYSTEMS-Two-Layer Systems

### Critical Tensile Strain-Dual Tandem Wheels-Numerical Problem

For the given pavement, determine critical tensile strain at the bottom of asphalt layer.

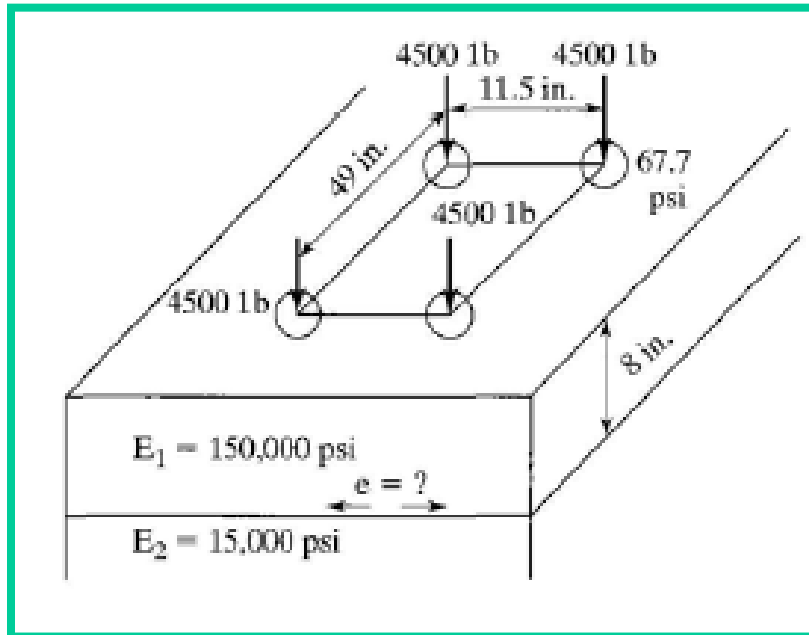

## Stresses and Strains in Flexible Pavements

### **LAYERED SYSTEMS-Three-Layer Systems**

**When the Poisson ratio is 0.5,**

$$\epsilon_z = \frac{1}{E}(\sigma_z - \sigma_r)$$

$$\epsilon_r = \frac{1}{2E}(\sigma_r - \sigma_z)$$

**The above equations indicate that the radial strain equals one-half of the vertical strain and is opposite in sign, or**

$$\epsilon_z = -2\epsilon_r$$