

CHAPTER FIVE

5. THE MOMENT – DISTRIBUTION METHOD

5.1. Introduction :-

Professor Hardy Cross of University of Illinois of U.S.A. invented this method in 1930. However, the method was well-established by the end of 1934 as a result of several research publications which appeared in the Journals of American Society of Civil Engineers (ASCE). In some books, the moment-distribution method is also referred to as a Hardy Cross method or simply a Cross method.

The moment-distribution method can be used to analyze all types of statically indeterminate beams or rigid frames. Essentially it consists in solving the linear simultaneous equations that were obtained in the slope-deflection method by successive approximations or moment distribution. Increased number of cycles would result in more accuracy. However, for all academic purposes, three cycles may be considered sufficient.

In order to develop the method, it will be helpful to consider the following problem. A propped cantilever subjected to end moments.

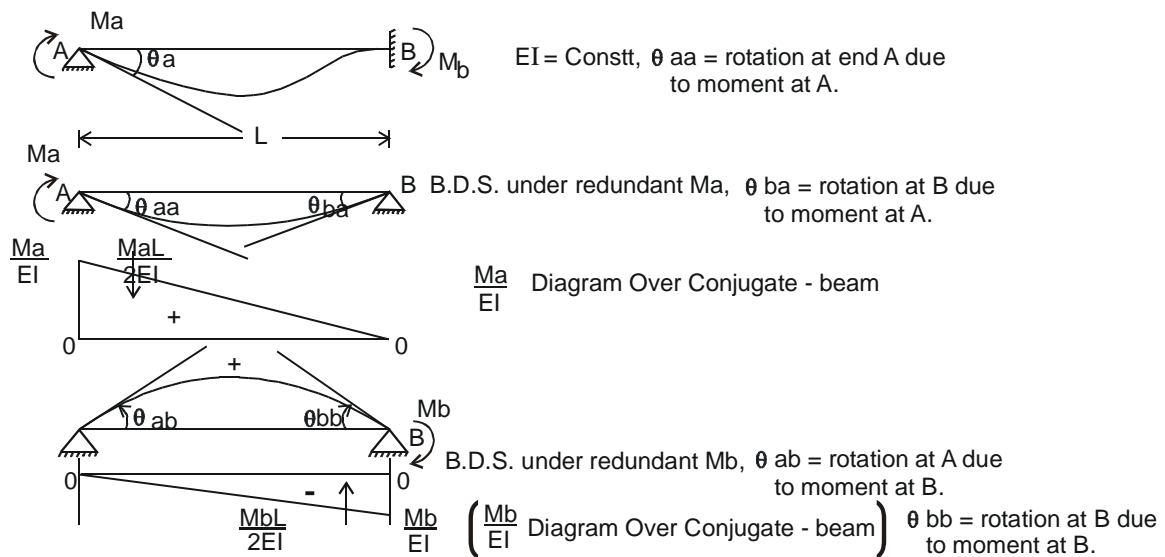

Note: Counterclockwise moment are considered (+ve)

Geometry requirement at B :-

$$\theta_b = 0, \text{ or } \theta_{ba} - \theta_{bb} = 0 \text{ and } (1) \theta_b = \theta_{ba} - \theta_{bb} = 0 \text{ (Slope at B).}$$

Now calculate all rotations shown in diagram by using conjugate beam method.

$$\theta_{aa} = \frac{\left(\frac{MaL}{2EI} \right) \times \frac{2}{3} L}{L} \quad \text{(By conjugate beam theorem)}$$

$$\theta_{aa} = \frac{MaL}{3EI}$$

$$\theta_{ab} = \frac{\left(\frac{MbL}{2EI}\right) \times \frac{L}{3}}{L} \quad (\text{By conjugate beam theorem})$$

$$\theta_{ab} = \frac{MbL}{6EI}$$

$$\theta_{ba} = \frac{\left(\frac{MaL}{2EI}\right) \times \left(\frac{L}{3}\right)}{L} \quad (\text{By conjugate beam theorem})$$

$$\theta_{ba} = \frac{MaL}{6EI}$$

$$\theta_{bb} = \frac{\left(\frac{MbL}{2EI}\right) \times \left(\frac{2L}{3}\right)}{L} \quad (\text{By conjugate beam theorem})$$

$$\theta_{bb} = \frac{MbL}{3EI}$$

Put θ_{ba} & θ_{bb} in (1)

$$\frac{MaL}{6EI} = \frac{MbL}{3EI}$$

$$\text{or} \quad Mb = \frac{Ma}{2} \quad (3)$$

If Ma is applied at A , then $Ma/2$ will be transmitted to the far end B .

Also, $\theta_a = \theta_{aa} - \theta_{ab}$ Geometry requirement at A . (2)

Put values of θ_{aa} and θ_{ab} , we have,

$$\begin{aligned} \theta_{aa} &= \frac{Ma.L}{3EI} - \frac{Mb.L}{6EI} \\ &= \frac{Ma.L}{3EI} - \frac{Ma.L}{12EI} \quad (\text{by putting } Mb = \frac{Ma}{2} \text{ for above}) \end{aligned}$$

$$\theta_{aa} = \frac{3 Ma.L}{12EI}$$

$$\text{or} \quad \theta_{aa} = \frac{Ma.L}{4EI} \quad \text{It can be written as}$$

$$\theta_{aa} = Ma \left(\frac{L}{4EI}\right)$$

$$\text{or} \quad Ma = \left(\frac{4EI}{L}\right) \theta_{aa} \quad (4)$$

5.2. STIFFNESS FACTOR :- The term $4EI/L$ is called the stiffness factor “stiffness factor is defined as the moment required to be applied at A to produce unit rotation at point A of the propped cantilever beam shown.”

5.3. CARRY-OVER FACTOR:- The constant $(1/2)$ in equation 3 is called the carry-over factor.

$$M_b = \frac{M_a}{2}$$

$$\frac{M_b}{M_a} = \frac{1}{2}$$

“Carry-over factor is the ratio of the moment induced at the far end to the moment applied at near end for a propped cantilever beam.” Now consider a simply supported beam carrying end moment at A.

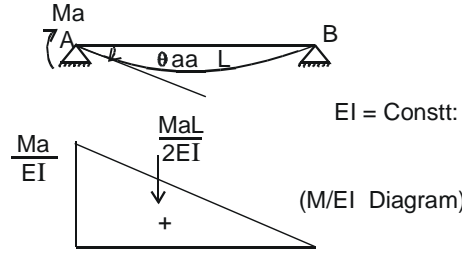

$$\theta_{aa} = \frac{M_a L}{2EI} \times \frac{2}{3} \frac{L}{L} = \frac{M_a L}{3EI} \quad \text{or} \quad M_a = \frac{3\theta_{aa} EI}{L}$$

Compare this M_a with that for a propped cantilever beam. We find that Stiffness factor of a simple beam is $3/4$ th of the cantilever beam. So propped cantilever beam is more stiff.

5.4. DISTRIBUTION FACTOR :-

Let us consider a moment applied at joint E as shown. Values shown are the stiffnesses of the members.

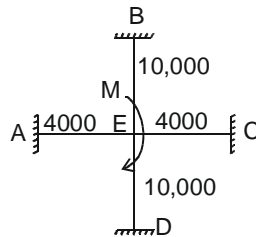

Consider a simple structure shown in the diagram which is under the action of applied moment M . For the equilibrium requirements at the joint, it is obvious that the summation of moments ($\sum M$) should be zero at the joint. This means that the applied moment ‘ M ’ will be distributed in all the members meeting at that joint in proportion to their stiffness factor. (This called stiffness – concept)

$$\text{Total stiffness factor} = 28,000 = 10,000 + 10,000 + 4,000 + 4,000$$

$$\text{So} \quad M_{ae} = M_{ec} = \frac{4000}{2800} \times M = \frac{1}{7} M$$

$$M_{be} = M_{de} = \frac{10000}{2800} \times M = \frac{5}{14} M. \quad \text{Therefore,}$$

“ Distribution at any end of a member factor is the ratio of the stiffness factor of the member being considered to the sum of the stiffnesses of all the members meeting at that particular continuous joint.”

EXAMPLE NO. 1:- Now take the continuous beam as shown in the figure and analyze it by moment distribution method.

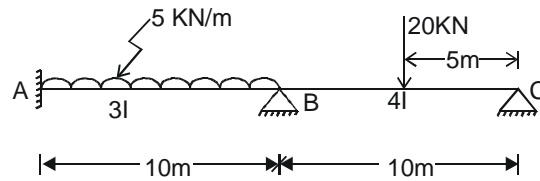

FIXED END MOMENTS :-

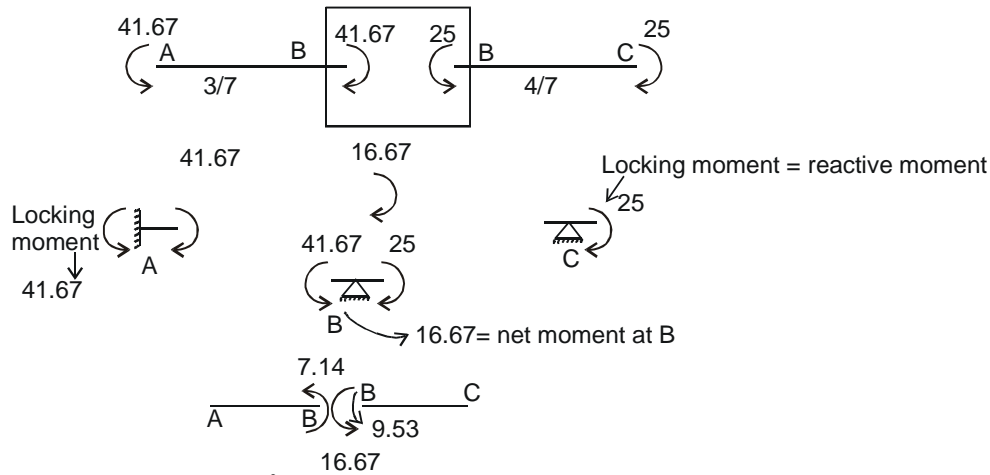

$$M_{fab} = \frac{5 \times 10^2}{12} = + 41.67 \text{ KN-m}$$

$$M_{fba} = - 41.67 \text{ KN-m}$$

$$M_{fbc} = \frac{20 \times 5^2 \times 5}{10^2} = + 25 \text{ KN-m}$$

$$M_{fcb} = - 25 \text{ KN-m}$$

$M = 16.67$ is to be distributed. (Net moment at B support)

Total stiffness of members of joint B = 7

so $M_{ab} = \frac{3}{7} \times M = \frac{3}{7} \times 16.67 = 7.14 \text{ KN-m}$

and $M_{bc} = \frac{4}{7} \times M = \frac{4}{7} \times 16.67 = 9.53 \text{ KN-m}$

The distribution factor at joint A is obviously equal to zero being a fixed joint. In the above diagram and the distribution factor at point C is infact 1 being an exterior pin support. (If we apply moment to the fixed support, same reactive moment will develop, so re-distribution moment is not created for all fixed supports and if a moment is applied at a pin support, we reactive moment develops.)

Fixed ended moments are sometimes referred to as the restraining moments or the locking moments. **“The locking moments are the moments required to hold the tangents straight or to lock the joints against rotation”.**

Consider the above diagram. Joint A is fixed joint. Therefore, the question of release of this joint does not arise. Now let us release joint to the net locking moments acting at joint B is 16.67 in the clockwise direction. After releasing the joint B, the same moment (16.67) will act at joint B in the counterclockwise direction. This net released moment will be distributed to various members framing into the joint B w.r.t. their distribution factors. In this case, 7.14 KN-m in the counterclockwise direction will act on member BA and 9.53 KN-m in the counterclockwise direction will act on member BC.

Now we hold the joint B in this position and give release to joint 'C'. The rotation at joint 'C' should be such that the released moment at joint 'C' should be 25 KN-m. The same procedure is repeated for a desired number of cycles. The procedure explained above corresponds to the first cycle.

5.5. STEPS INVOLVED IN MOMENT DISTRIBUTION METHOD:-

The steps involved in the moment distribution method are as follows:-

- (1) Calculate fixed end moments due to applied loads following the same sign convention and procedure, which was adopted in the slope-deflection method.
- (2) Calculate relative stiffness.
- (3) Determine the distribution factors for various members framing into a particular joint.
- (4) Distribute the net fixed end moments at the joints to various members by multiplying the net moment by their respective distribution factors in the first cycle.
- (5) In the second and subsequent cycles, carry-over moments from the far ends of the same member (carry-over moment will be half of the distributed moment).
- (6) Consider this carry-over moment as a fixed end moment and determine the balancing moment. This procedure is repeated from second cycle onwards till convergence

For the previous given loaded beam, we attempt the problem in a tabular form..

$$K = \frac{I}{L} = \frac{3}{10} \times 10 = 3$$

and $\frac{4}{10} \times 10 = 4$

Joints.		A	B		C
Members.		AB	BA	BC	CB
K		3	3	4	4
Cycle No.	D. Factor	0	0.428	0.572	1
1	F.E.M.	+ 41.67	- 41.67	+ 25	- 25
	Balancing moment.	0	+ 7.14	+ 9.53	+ 25
2	COM.	+ 3.57	0	+ 12.5	+ 4.77
	Bal.	0	- 5.35	- 7.15	- 4.77
3	COM.	- 2.67	0	- 2.385	- 3.575
	Bal.	0	+ 1.02	+ 1.36	+ 3.575
Σ		+ 42.57	- 38.86	+ 38.86	0

NOTE:- Balancing moments are, in fact, the distributed moments.

Now draw SFD , BMD and hence sketch elastic curve as usual by drawing free-body diagrams.

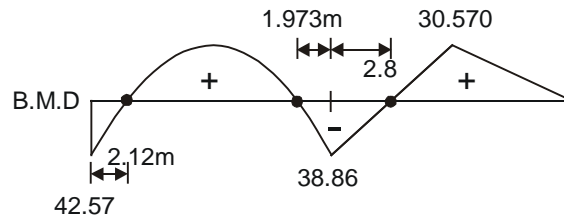
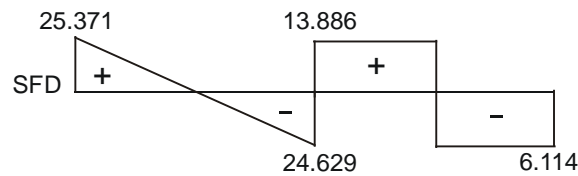
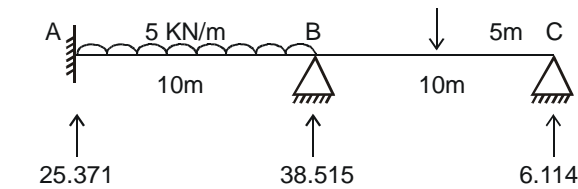
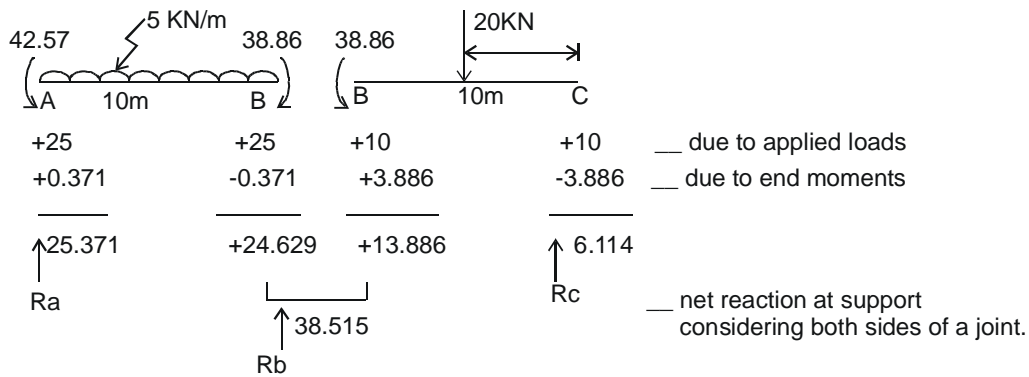

POINTS OF CONTRAFLEXURES :-

Near A: Span AB

$$M_x = 25.371 X - 42.57 - 2.5 X^2 = 0 \quad \text{See free-body diagram}$$

$$2.5 X^2 - 25.371 X + 42.57 = 0$$

$$X = \frac{25.371 \pm \sqrt{(25.371)^2 - 4 \times 2.5 \times 42.57}}{2 \times 2.5}$$

$$X = 2.12 \text{ m}$$

Near B :-

$$Mx' = -38.86 + 24.629 X' - 2.5 X'^2 = 0$$

$$2.5 X'^2 - 24.629 X' + 38.86 = 0$$

$$X' = \frac{24.629 \pm \sqrt{(24.629)^2 - 4 \times 2.5 \times 38.86}}{2 \times 2.5}$$

$$X' = 1.973 \text{ m}$$

Span BC (near B)

$$MX'' = -38.86 + 13.886X'' = 0$$

$$X'' = 2.8 \text{ m}$$

EXAMPLE NO. 2:- Analyze the following beam by moment-distribution method. Draw S.F. & B.M. diagrams. Sketch the elastic curve.

SOLUTION :-

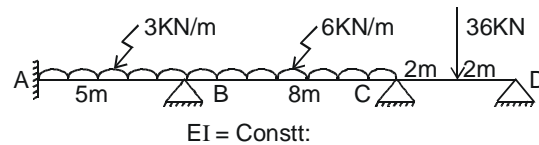

Step 1: **FIXED END MOMENTS :-**

$$M_{fab} = + \frac{3(5)^2}{12} = +6.25 \text{ KN-m}$$

$$M_{fba} = -6.25 \text{ KN-m}$$

$$M_{fbc} = + \frac{6 \times 8^2}{12} = +32 \text{ KN-m}$$

$$M_{fcb} = -32 \text{ KN-m}$$

$$M_{fcd} = \frac{36 \times 2^2 \times 2}{4^2} + 18 \text{ KN-m}$$

$$M_{fdc} = -18 \text{ KN-m}$$

Step 2: **RELATIVE STIFFNESS :-**

Member.	I	L	$\frac{I}{L}$	Krel.
AB	1	5	$\frac{1}{5} \times 40$	8
BC	1	8	$\frac{1}{8} \times 40$	5
CD	1	4	$\frac{1}{4} \times 40$	10

STEP (3) DISTRIBUTION FACTOR :-

Joint.	D.F.	Member.
A	0	AB
B	$\frac{8}{13} = 0.615$	BA
B	$\frac{5}{13} = 0.385$	BC
C	$\frac{5}{15} = 0.333$	CB
C	$\frac{10}{15} = 0.667$	CD
D	$\left(\frac{10}{10+0}\right) = 1$	DC

Attempt and solve the problem now in a tabular form by entering distribution factors and FEM's.

Joint		A	B		C		D
Members.		AB	BA	BC	CB	CD	DC
K		8	8	5	5	10	10
Cycle No.	D.F.	0	0.615	0.385	0.333	0.667	1
1	F.E.M	+ 6.25	-6.25	+32	- 32	+ 18	- 18
	Bal.	0	-15.836	-9.914	+4.662	+9.338	+ 18
2	Com.	- 7.918	0	+2.331	-4.957	+ 9	+4.669
	Bal.	0	-1.433	-0.897	-1.346	-2.697	-4.669
3	Com.	- 0.7165	0	-0.673	-0.4485	-2.3345	-1.3485
	Bal.	0	+0.414	+0.259	+ 0.927	+1.856	+1.3485
	Σ	- 2.385	-23.141	+23.11	-33.16	+33.16	0

Usually for academic purposes we may stop after 3 cycles.

Applying above determined net end moments to the following segments of a continuous beam, we can find reactions easily.

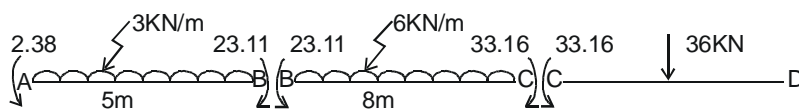

+7.5	+7.5	+24	+24	+18	+18	__ reaction due to applied load
-5.098	+5.098	-1.261	+1.261	+8.29	-8.29	__ reaction due to end moment
↑ 2.402	+12.598 + (22.739)		+25.261 +26.29		↑ 9.71	__ net reaction of a support
	↑ 35.337		↑ 51.551			Final Values considering both sides of a support.

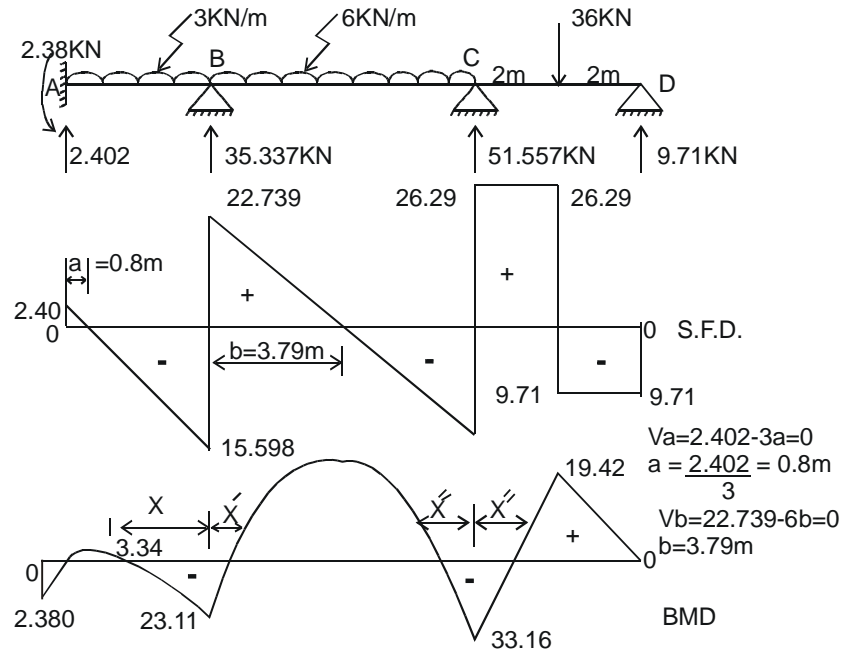
**POINTS OF CONTRAFLEXURES :-**

Span AB (near A)

$$MX = 2.38 + 2.402 X - 1.5 X^2 = 0$$

$$1.5 X^2 - 2.402 X - 2.38 = 0$$

$$X = \frac{2.402 \pm \sqrt{(2.402)^2 + 4 \times 1.5 \times 2.38}}{2 \times 1.5}$$

$$X = 2.293 \text{ m}$$

Span BC (near B)

$$MX' = -23.11 + 22.739 X' - 3 X'^2 = 0$$

$$3 X'^2 - 22.739 X' + 23.11 = 0$$

$$X' = \frac{22.739 \pm \sqrt{(22.739)^2 - 4 \times 3 \times 23.11}}{2 \times 3}$$

$$X' = 1.21 \text{ m}$$

Span BC (near C)

$$MX'' = -33.16 + 25.261 X'' - 3 X''^2 = 0$$

$$3 X''^2 - 25.261 X'' + 33.16 = 0$$

$$X'' = \frac{25.261 \pm \sqrt{(25.261)^2 - 4 \times 3 \times 33.16}}{2 \times 3}$$

$$X'' = 1.63 \text{ m}$$

Span CD (near C)

$$MX''' = -33.16 + 26.29 X''' = 0$$

$$X''' = 1.26 \text{ m}$$

5.6. CHECK ON MOMENT DISTRIBUTION :-

The following checks may be supplied.

- (i) Equilibrium at joints.
- (ii) Equal joint rotations or continuity of slope.

General form of slope-deflection equations is

$$M_{ab} = M_{fab} + K_{rel} (-2\theta_a - \theta_b) \quad \rightarrow (1)$$

$$M_{ba} = M_{fba} + K_{rel} (-2\theta_b - \theta_a) \quad \rightarrow (2)$$

From (1)

$$\theta_b = \frac{-(M_{ab} - M_{fab})}{K_{rel}} - 2\theta_a \quad \rightarrow (3)$$

Put (3) in (2) & solve for θ_a .

$$M_{ba} = M_{fba} + K_{rel} \left[\frac{2(M_{ab} - M_{fab})}{K_{rel}} + 4\theta_a - \theta_a \right]$$

$$M_{ba} = M_{fba} + K_{rel} \left[\frac{2(M_{ab} - M_{fab}) + 3\theta_a K_{rel}}{K_{rel}} \right]$$

$$(M_{ba} - M_{fba}) = 2(M_{ab} - M_{fab}) + 3\theta_a K_{rel}$$

$$3\theta_a K_{rel} = (M_{ba} - M_{fba}) - 2(M_{ab} - M_{fab})$$

$$\theta_a = \frac{(M_{ba} - M_{fba}) - 2(M_{ab} - M_{fab})}{3 K_{rel}} \quad \rightarrow (4)$$

or
$$\theta_a = \frac{(M_{ba} - M_{fba}) - 2(M_{ab} - M_{fab})}{K_{rel}} \quad \rightarrow (5)$$

$$\theta_a = \frac{\text{Change at far end} - 2(\text{Change at near end})}{K_{rel}}$$

or
$$\theta_a = \frac{2(\text{Change at near end}) - (\text{Change at far end})}{-K_{rel}}$$

$$\theta_a = \frac{(\text{Change at near end}) - 1/2(\text{change at far end})}{-K_{rel}}$$

Put (4) in (3) & solve for θ_b .

$$\begin{aligned} \theta_b &= -\frac{(M_{ab} - M_{fab})}{K_{rel}} - \frac{2(M_{ba} - M_{fba})}{3 K_{rel}} + \frac{4(M_{ab} - M_{fab})}{3 K_{rel}} \\ &= \frac{-3 M_{ab} + 3 M_{fab} - 2 M_{ba} + 2 M_{fba} + 4 M_{ab} - 4 M_{fab}}{3 K_{rel}} \end{aligned}$$

$$\begin{aligned}
 &= \frac{(M_{ab} - M_{fab}) - 2(M_{ba} - M_{fba})}{3 K_{rel}} \\
 &= \frac{2(M_{ba} - M_{fba}) - (M_{ab} - M_{fab})}{-3 K_{rel}} \\
 &= \frac{(M_{ba} - M_{fba}) - 1/2(M_{ab} - M_{fab})}{-3/2 K_{rel}} \\
 &= \frac{(M_{ba} - M_{fba}) - 1/2(M_{ab} - M_{fab})}{-1.5 K_{rel}} \\
 &= \frac{(M_{ba} - M_{fba}) - 1/2(M_{ab} - M_{fab})}{-K_{rel}}
 \end{aligned}$$

$$\theta_b = \frac{(\text{Change at near end}) - 1/2(\text{Change at far end})}{-K_{rel}}$$

These two equations serve as a check on moment – Distribution Method.

EXAMPLE NO. 3:- Analyze the following beam by moment-distribution method. Draw shear force and B.M. diagrams & sketch the elastic curve.

SOLUTION :-

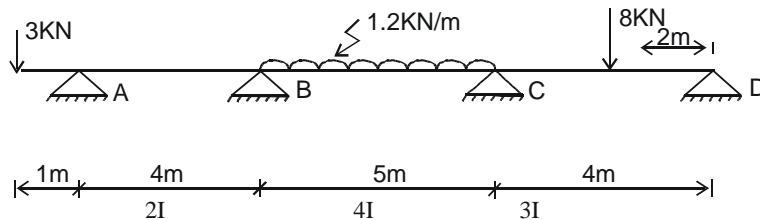

Step 1: **FIXED END MOMENTS :-**

$M_{fab} = M_{fba} = 0$ (There is no load on span AB)

$$M_{fbc} = \frac{+ 1.2 \times 5^2}{12} = + 2.5 \text{ KN-m}$$

$$M_{fcb} = - 2.5 \text{ KN-m}$$

$$M_{fcd} = \frac{8 \times 2^2 \times 2}{4^2} = + 4 \text{ KN-m}$$

$$M_{fdc} = - 4 \text{ KN-m}$$

Step 2: **RELATIVE STIFFNESS (K) :-**

Span	I	L	$\frac{I}{L}$	Krel
AB	2	4	$\frac{2}{4} \times 20$	10
BC	4	5	$\frac{4}{5} \times 20$	16
CD	3	4	$\frac{3}{4} \times 20$	15

Moment at A = $3 \times 1 = 3 \text{ KN-m}$. (Known from the loaded given beam according to our sign convention.)

The applied moment at A is counterclockwise but fixing moments are reactive moments.

Step 3: **D.F.**

Joint	D.F.	Members.
A	1	AB
B	$\frac{10}{26} = 0.385$	BA
B	$\frac{16}{26} = 0.615$	BC
C	$\frac{16}{31} = 0.516$	CB
C	$\frac{15}{31} = 0.484$	CD
D	$\left(\frac{4}{4+0}\right) = 1$	DC

Now attempt the problem in a tabular form to determine end moments.

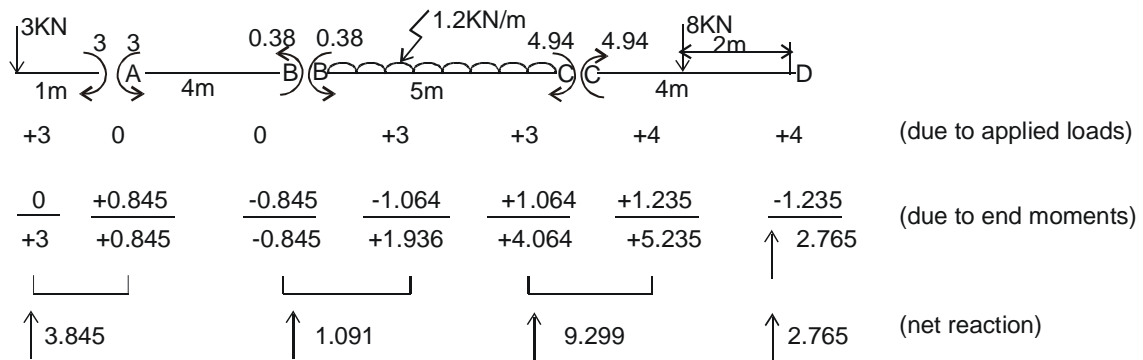

Insert Page No. 294-A

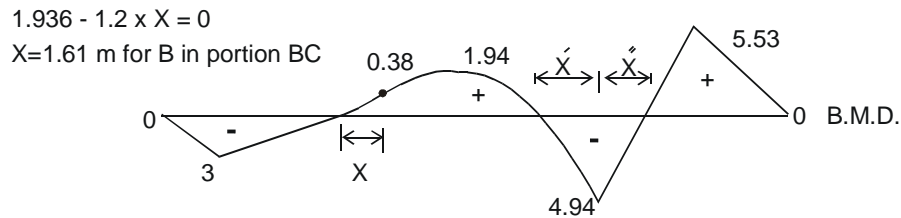
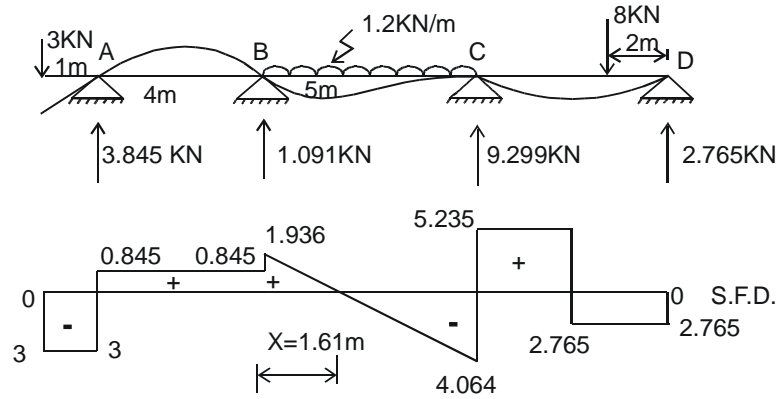

LOCATION OF POINTS OF CONTRAFLEXURES :-

$$\begin{aligned}
 MX &= -0.845 X + 0.38 = 0 \\
 X &= 0.45 \text{ m from B. in portion BA.} \\
 MX' &= 4.064 X' - 4.94 - 0.6 X'^2 = 0 \\
 0.6 X'^2 - 4.064 X' + 4.94 &= 0 \\
 X' &= \frac{4.064 \pm \sqrt{(4.064)^2 - 4 \times 0.6 \times 4.94}}{2 \times 0.6} \\
 &= 1.59 \text{ m from C in span BC} \\
 MX'' &= -4.94 + 5.235 X'' = 0 \\
 X'' &= 0.94 \text{ m from C in span CD}
 \end{aligned}$$

5.7. MOMENT-DISTRIBUTION METHOD (APPLICATION TO SINKING OF SUPPORTS) :-

Consider a generalized differential sinking case as shown below:

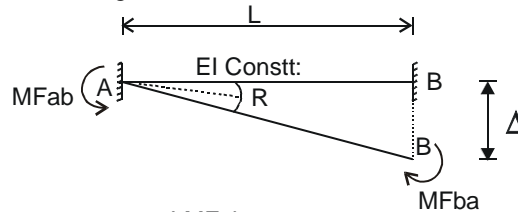

Bending moments are induced due to differential sinking of supports.

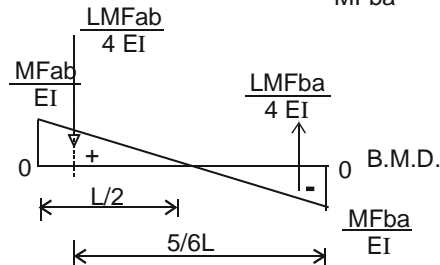

(1) Change of slope between points A and B (θ_{ab}) = 0 (First moment–area theorem)

$$(1) \frac{L}{4EI} M_{fab} - \frac{L}{4EI} M_{fba} = 0$$

$$\text{or} \quad M_{fab} = M_{fba}$$

(2) $\Delta = \frac{L}{4EI} M_{fab} \left(\frac{5}{6}L\right) - \frac{L}{4EI} M_{fba} \left(\frac{L}{6}\right)$ (Second moment area theorem), simplify.

$$\begin{aligned} 6EI \Delta &= \frac{5L^2 M_{fab} - L^2 M_{fba}}{4} \\ &= \frac{4 L^2 M_{fab}}{4} \end{aligned}$$

$$6EI \Delta = L^2 M_{fab}$$

$$\text{or} \quad M_{fab} = M_{fba} = \frac{6EI \Delta}{L^2}, \quad \text{where} \quad R = \frac{\Delta}{L}$$

$$M_{fab} = M_{fba} = \frac{6EI R}{L}$$

Equal FEM's are induced due to differential sinking in one span.

The nature of the fixed end moments induced due to the differential settlement of the supports depends upon the sign of R. If R is (+ve) fixing moment is positive or vice versa. Care must be exercised in working with the absolute values of the quantity $6EI R/L$ which should finally have the units of B.M. (KN–m). Once the fixed end moments have been computed by using the above formula, these are distributed in a tabular form as usual.

EXAMPLE NO.4:– Analyse the continuous beam shown due to settlement at support B by moment – distribution method. Apply usual checks & draw S.F., B.M. diagrams & hence sketch the elastic curve take $E = 200 \times 10^6$, $I = 400 \times 10^{-6} \text{ m}^4$

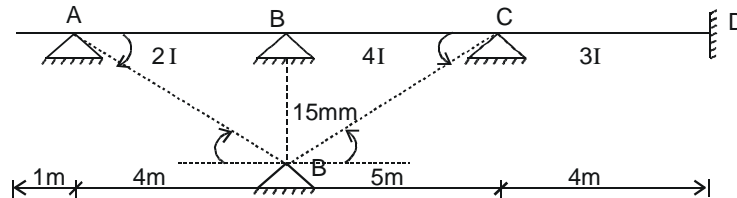

SOLUTION :-

Step (1) **F.E.M.** In such cases, Absolute Values of FEM's are to be calculated

$$M_{fab} = M_{fba} = \frac{6EI\Delta}{L^2} = \frac{6(200 \times 10^6)(2 \times 400 \times 10^{-6})(+0.015)}{4^2}$$

$$= + 900 \text{ KN-m} \quad (\text{positive because angle } R = \frac{\Delta}{L} \text{ is clockwise}).$$

$$M_{fbc} = M_{fcb} = \frac{6 (200 \times 10^6) (4 \times 400 \times 10^{-6})(-0.015)}{5^2}$$

= - 1152 KN-m (Because angle is counter clockwise)

$M_{fcd} = M_{fdc} = 0$

Step 2: **RELATIVE STIFFNESS (K) :-**

Members.	I	L	$\frac{I}{L}$	Krel.
AB	2	4	$\frac{2}{4} \times 20$	10
BC	4	5	$\frac{4}{5} \times 20$	16
CD	3	4	$\frac{3}{4} \times 20$	15

Step 3: **D.F :-** (Distribution Factors)

Joint	D.F.	Members.
A	1	AB
B	0.385	BA
B	0.615	BC
C	0.516	CB
C	0.484	CD
D	1	DC

We attempt and solve the problem in a tabular form as given below:

Joint		A	B		C		D
Members		AB	BA	BC	CB	CD	DC
K		10	10	16	16	15	15
Cycle	D.F.	1.0	0.385	0.615	0.516	0.484	0
1	FEM.	+ 900	+ 900	- 1152	- 1152	0	0
	BAL.	- 900	+ 97.02	+154.98	+ 594.43	+ 557.57	0
2	COM.	+ 48.51	- 450	+ 297.22	+ 77.49	0	+ 278.79
	BAL.	- 48.51	+ 58.82	+ 93.96	- 39.98	- 37.51	0
3	COM.	+ 29.41	- 24.255	- 19.99	+ 46.98	0	- 18.75
	BAL.	- 29.41	+ 17.03	+ 27.21	- 24.24	- 22.74	0
4	COM.	+ 8.515	- 14.705	- 12.12	+ 13.605	0	- 11.37
	BAL.	- 8.515	+ 10.328	+ 16.497	- 7.020	- 6.585	0
5	COM.	+ 5.164	- 4.258	- 3.51	+ 8.249	0	- 3.293
	BAL.	- 5.164	+ 2.991	+ 4.777	- 4.256	- 3.493	0
End Moment.		0	+ 592.97	- 592.97	- 486.74	+ 486.74	+245.38
(change) near end.		- 900	- 307.03	+ 559.03	+ 665.26	+ 486.74	+ 245.38
-1/2(change) far end.		+ 153.515	+ 450	- 332.63	- 279.515	- 122.69	- 243.37
Σ		- 746.485	+ 142.97	+ 226.4	+ 385.745	+367.05	+ 2.01
$\theta_{rel} = \frac{\Sigma}{-K}$		+ 74.65	- 14.30	- 14.15	- 24.11	- 24.47	- 0.134

θ checks have been satisfied. Now Draw SFD , BMD and sketch elastic curve as usual yourself.

5.8. APPLICATION TO FRAMES (WITHOUT SIDE SWAY) :-

The reader will find not much of difference for the analysis of such frames.

EXAMPLE NO. 5:- Analyze the frame shown below by Moment Distribution Method.

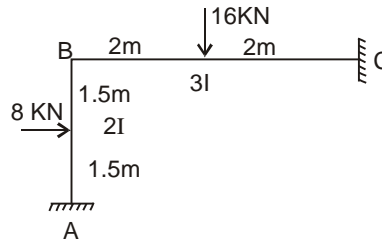
**SOLUTION :-**

Step 1: **F.E.M :-**

$$M_{fab} = + \frac{8 \times 1.5^2 \times 1.5}{3^2} = + 3 \text{ KN-m}$$

$$M_{fba} = - \frac{8 \times 1.5^2 \times 1.5}{3^2} = - 3 \text{ KN-m}$$

$$M_{fbc} = + \frac{16 \times 2^2 \times 2}{4^2} = + 8 \text{ KN-m}$$

$$M_{fcb} = - 8 \text{ KN-m}$$

Step 2: **RELATIVE STIFFNESS (K) :-**

Members.	I	L	$\frac{I}{L}$	Krel
AB	2	3	$\frac{2}{3} \times 12$	8
BC	3	4	$\frac{3}{4} \times 12$	9

Step 3: **D.F :-** (Distribution Factors)

Joint.	D.F.,	Member.
A	0	AB
B	0.47	BA
B	0.53	BC
C	0	CB

Example is now solved in a tabular form as given below:

Joint		A	B		C
Members		AB	BA	BC	CB
K		8	8	9	9
Cycle	D.F.	0	0.47	0.53	0
1	Fem.	+3	-3	+8	-8
	Bal.	0	-2.35	-2.65	0
2	Com.	-1.175	0	0	-1.325
	Bal.	0	0	0	0
3	Com.	0	0	0	0
	Bal.	0	0	0	0
Σ		+1.175	-5.35	+5.35	-9.325
(Change) near end		-1.825	-2.35	-2.65	-1.325
-1/2(change)far end		+1.175	+0.5875	+0.6625	+1.325
Sum		0	-1.7625	-1.9875	0
$\theta_{rel} = \text{Sum}/(-K)$		0	+0.22	+0.22	0

θ Checks have been satisfied.

DETERMINATION OF SUPPORT REACTIONS, SFD AND BMD.

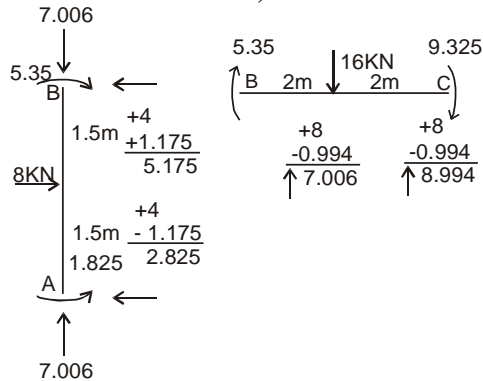

B,M. & S.F. DIAGRAMS :-

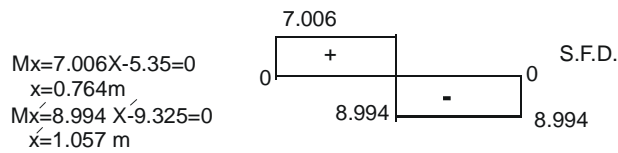
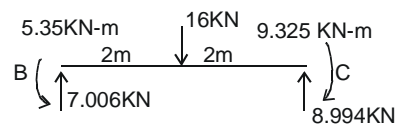

$$M_x = 7.006X - 5.35 = 0$$

$$x = 0.764 \text{ m}$$

$$M_x = 8.994 X - 9.325 = 0$$

$$x = 1.057 \text{ m}$$

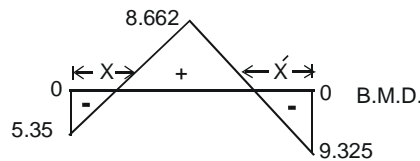

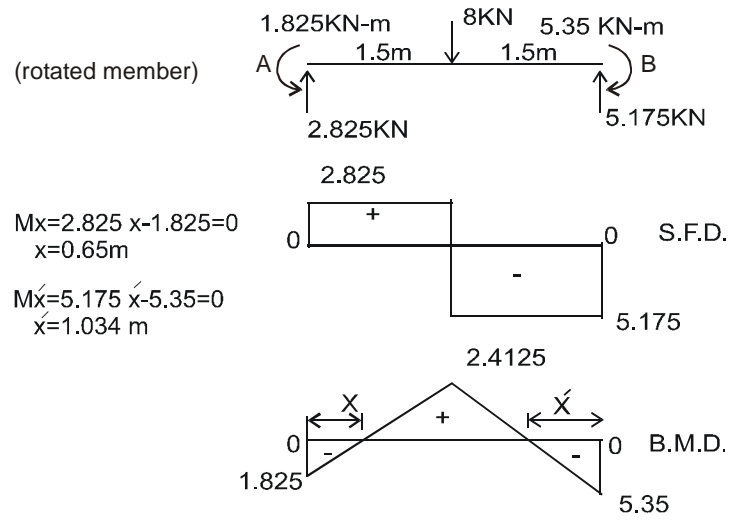

Note: It is a column rotated through 90.

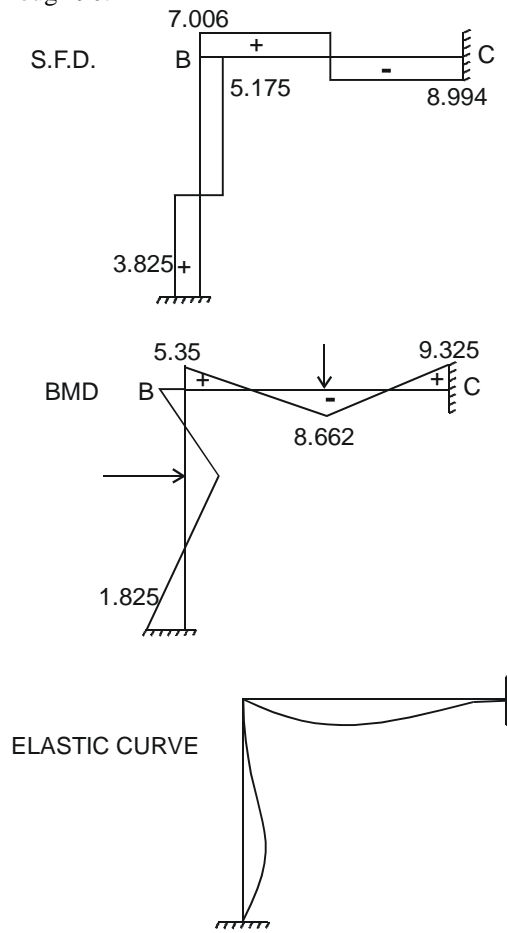

EXAMPLE NO.6:– Analyze the frame shown in the fig. by Moment Distribution Method.

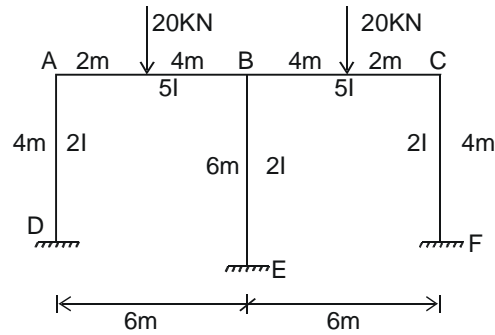

SOLUTION :-

Step 1: **F.E.M :-**

$$M_{fab} = \frac{+ 20 \times 4^2 \times 2}{6^2} = + 17.778 \text{ KN-m}$$

$$M_{fba} = \frac{- 20 \times 2^2 \times 4}{6^2} = - 8.889 \text{ KN-m}$$

$$M_{fbc} = \frac{+ 20 \times 2^2 \times 4}{6^2} = + 8.889 \text{ KN-m}$$

$$M_{fcb} = \frac{- 20 \times 4^2 \times 2}{6^2} = - 17.778 \text{ KN-m}$$

$$M_{fad} = M_{fda} = 0$$

$$M_{fbe} = M_{feb} = 0 \quad \text{There are no loads on these spans.}$$

$$M_{fcf} = M_{ffc} = 0$$

Step 2: **RELATIVE STIFFNESS (K) :-**

Members.	I	L	$\frac{I}{L}$	Krel
AB	5	6	$\frac{5}{6} \times 12$	10
BC	5	6	$\frac{5}{6} \times 12$	10
AD	2	4	$\frac{2}{4} \times 12$	6
BE	2	6	$\frac{2}{6} \times 12$	4
CF	2	4	$\frac{2}{4} \times 12$	6

Step 3: **Distribution Factor (D.F):-**

Joint	Member	D.F.
A	AD	0.375
A	AB	0.625
B	BA	0.417
B	BE	0.166
B	BC	0.417
C	CB	0.625
C	CF	0.375
F	FC	0
E	EB	0
D	DA	0

Now we attempt the problem in a tabular form. Calculation table is attached

Draw SFD, BMD and sketch elastic curve now.

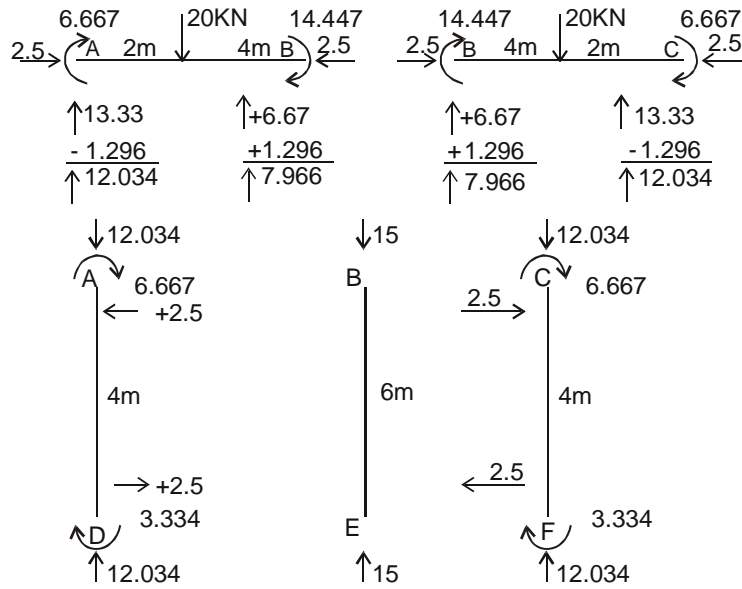

Insert Page No. 304-A

B.M. & SHEAR FORCE DIAGRAMS :-

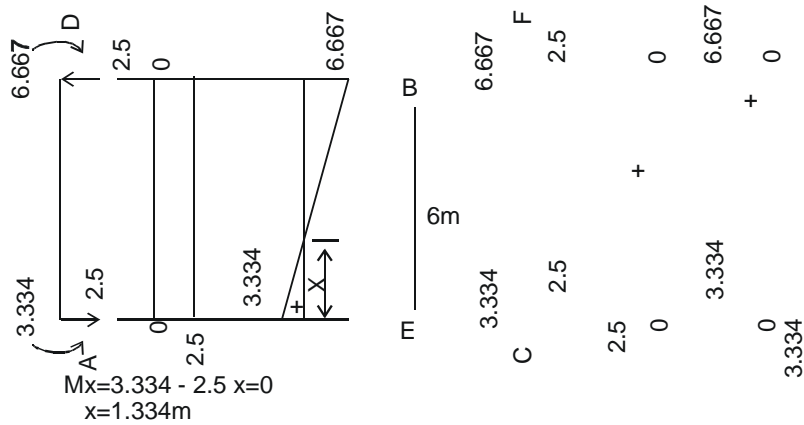
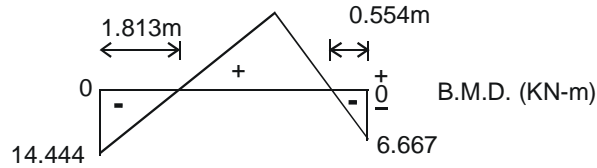
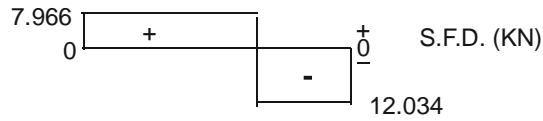
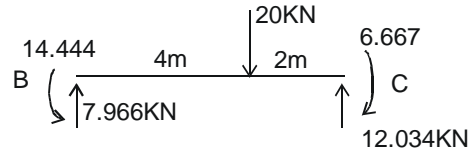
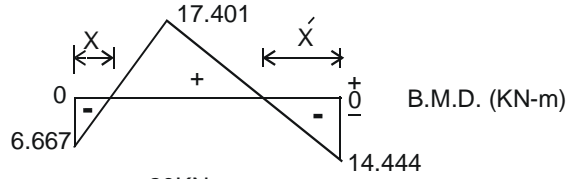
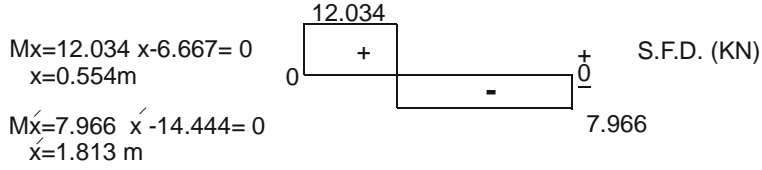
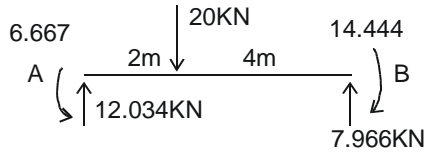

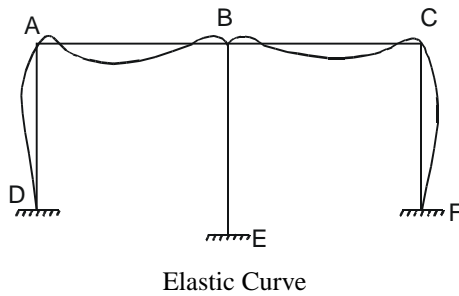

EXAMPLE NO. 7:- Analyze the following frame by Moment Distribution Method.

SOLUTION:- This is a double story frame carrying gravity and lateral loads and hence would be able to sway both at upper and lower stories.

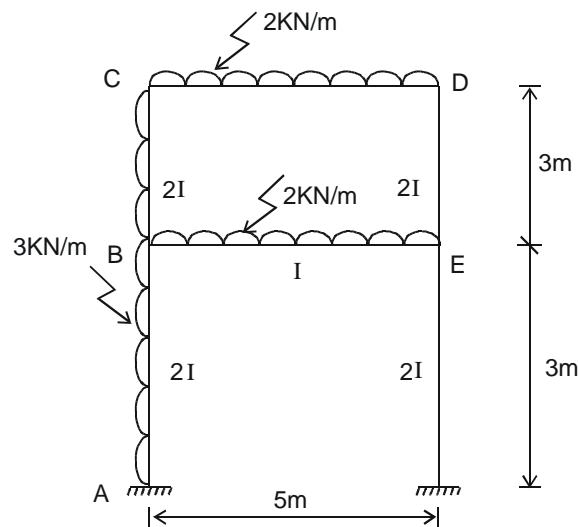

Step 1: **F.E.Ms Due to applied loads :-**

$$M_{fab} = \frac{3 \times 3^2}{12} = + 2.25 \text{ KN-m}$$

$$M_{fba} = - 2.25 \text{ KN-m}$$

$$M_{fbc} = \frac{3 \times 3^2}{12} = + 2.25$$

$$M_{fcb} = - 2.25 \text{ KN-m.}$$

$$M_{fbe} = M_{fcd} = \frac{2.5^2}{12} = + 4.167 \text{ KN-m}$$

$$M_{feb} = M_{fdc} = - 4.167 \text{ KN-m}$$

$$M_{fde} = M_{fed} = 0$$

$$M_{fef} = M_{ffe} = 0$$

Step 2: **Relative Stiffness :-**

Member	I	L	$\frac{I}{L}$	Krel
AB	2	3	$\frac{2}{3} \times 15$	10
BC	2	3	$\frac{2}{3} \times 15$	10
DE	2	3	$\frac{2}{3} \times 15$	10
EF	2	3	$\frac{2}{3} \times 15$	10
CD	1	5	$\frac{1}{5} \times 15$	3
BE	1	5	$\frac{1}{5} \times 15$	3

Step 3: **F.E.Ms. Due to side Sway of upper storey :-**

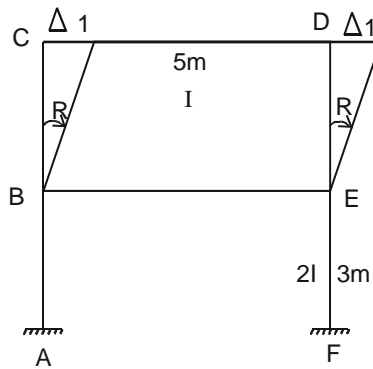

$$M_{fbc} = M_{fcb} = \frac{+6EI \Delta}{L^2} = \frac{+6E(2I) \Delta}{3^2} \times 900 = +1200 \text{ (Note: 900 value is an arbitrary multiplier)}$$

$$M_{fde} = M_{fed} = \frac{+6EI \Delta}{L^2} = \frac{+6E(2I) \Delta}{3^2} \times 900 = +1200 \text{ (Because R is clockwise)}$$

Step 4: **F.E.Ms. Due To Side Sway Of Lower Storey :-**

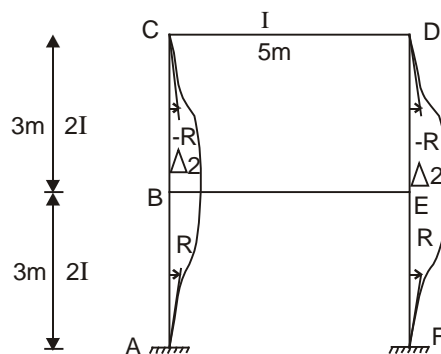

$$M_{fbc} = M_{fcb} = M_{fde} = M_{fed} = \frac{-6EI(2I) \Delta}{9} \times 900 = -1200$$

(R is counter clockwise so negative)

$$M_{fab} = M_{fba} = \frac{+6EI(2I) \Delta}{9} \times 900 = +1200$$

(R is clockwise, So positive)

$$M_{fef} = M_{ffe} = \frac{+6EI(2I) \Delta}{9} \times 900 = +1200$$

(R is clockwise, So positive)

Determination Of Shear Co-efficients (K₁, K₂) for upper and lower stories :-

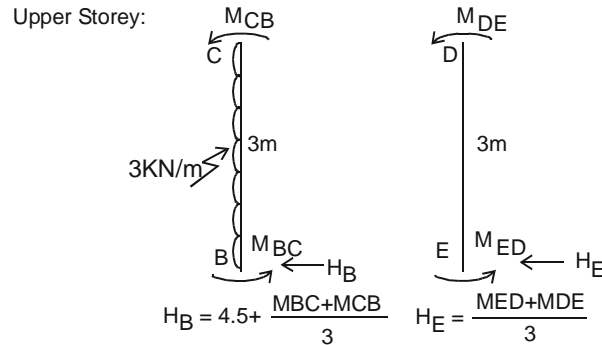

Shear Conditions :

1. Upper story $H_b + H_e = 0$ (1) where H_b and H_e values in terms of end moments are shown in the relevant diagram.
2. Lower storey $H_a + H_f = 0$ (2)

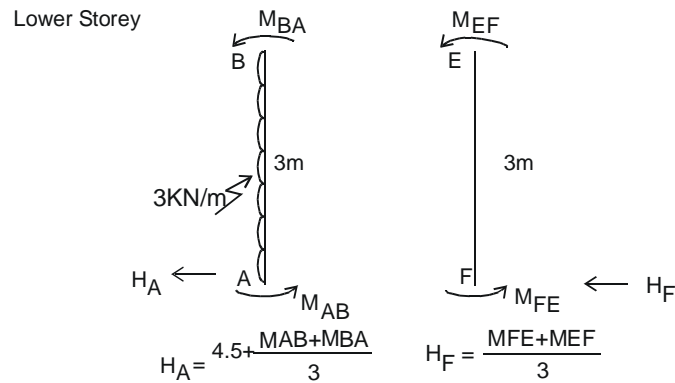

Where H_a and H_f values in terms of end moments are shown in the relevant diagram
 Now we attempt the problem in a tabular form. There would be three tables, one due to loads (Table-A), other due to FEMs of upper story (Table-B) and lower story (Table-C).
 Insert these three tables here. **Now end moment of a typical member would be the sum of moment due**

to applied loads $\pm K_1 \times$ same end moment due to sway of upper story $\pm K_2 \times$ same end moment due to sway of lower story. Picking up the values from tables and inserting as follows we have.

$$M_{ab} = 1.446 - K_1(143.66) + K_2(1099.625).$$

$$M_{ba} = -3.833 - K_1(369.4) + K_2(1035.46)$$

$$M_{bc} = -0.046 + K_1(522.71) - K_2(956.21)$$

$$M_{cb} = -4.497 + K_1(314.84) - K_2(394.38).$$

$$M_{cd} = +4.497 - K_1(314.84) + K_2(394.38)$$

$$M_{dc} = -3.511 - K_1(314.84) + K_2(394.38)$$

$$M_{de} = +3.511 + K_1(314.84) - K_2(394.38)$$

$$M_{ed} = +2.674 + K_1(522.71) - K_2(956.29).$$

$$M_{ef} = +1.335 - K_1(369.4) + K_2(1035.46)$$

$$M_{fe} = +0.616 - K_1(193.66) + K_2(1099.625).$$

$$M_{be} = +3.878 - K_1(153.32) - K_2(79.18)$$

$$M_{eb} = 4.009 - K_1(153.32) - K_2(79.18)$$

Put these expressions of moments in equations (1) & (2) & solve for K_1 & K_2 .

$$\begin{aligned} & -0.046 + 522.71 K_1 - 956.21 K_2 - 4.497 + 314.84 K_1 - 394.38 K_2 \\ & + 2.674 + 522.71 K_1 - 956.29 K_2 + 3.511 + 314.84 K_1 - 394.38 K_2 = 13.5 \\ & 1675.1 K_1 - 2701.26 K_2 - 11.858 = 0 \end{aligned} \quad \rightarrow (3)$$

$$\begin{aligned} & 1.446 - 143.66 K_1 + 1099.625 K_2 - 3.833 - 369.4 K_1 + 1035.46 K_2 \\ & + 0.646 - 193.66 K_1 + 1099.625 K_2 + 1.335 - 369.4 K_1 + 1035.46 K_2 = 40.5 \\ & - 1076.12 K_1 + 4270.17 K_2 - 40.936 = 0 \end{aligned} \quad \rightarrow (4)$$

From (3)

$$K_2 = \left(\frac{1675.10 K_1 - 11.858}{2701.26} \right) \quad \rightarrow (5)$$

Put K_2 in (4) & solve for K_1

$$-1076.12 K_1 + 4270.17 \left(\frac{1675.10 K_1 - 11.858}{2701.26} \right) - 40.936 = 0$$

$$-1076.12 K_1 + 2648 K_1 - 18.745 - 40.936 = 0$$

$$1571.88 K_1 - 59.68 = 0$$

$$K_1 = 0.03797$$

$$\text{From (5)} \quad \Rightarrow \quad K_2 = \frac{1675.1(0.03797) - 11.858}{2701.26}$$

$$K_2 = 0.01915$$

Putting the values of K1 and K2 in above equations , the following end moments are obtained.
FINAL END MOMENTS :-

$$M_{ab} = 1.446 - 0.03797 \times 143.66 + 0.01915 \times 1099.625 = + 17.05 \text{KN-m}$$

$$M_{ba} = + 1.97 \text{KN-m}$$

$$M_{bc} = + 1.49 \text{KN-m.}$$

$$M_{cb} = - 0.095 \text{KN-m.}$$

$$M_{cd} = + 0.095 \text{KN-m}$$

$$M_{dc} = - 7.91 \text{KN-m}$$

$$M_{de} = + 7.91 \text{KN-m}$$

$$M_{ed} = + 4.21 \text{KN-m}$$

$$M_{ef} = + 7.14 \text{KN-m}$$

$$M_{fe} = + 14.32 \text{KN-m}$$

$$M_{be} = - 3.46 \text{KN-m}$$

$$M_{eb} = - 11.35 \text{KN-m}$$

These values also satisfy equilibrium of end moments at joints. For simplicity see end moments at joints C and D.

Space for notes:

Insert Page No. 309-A-B

Insert Page No. 309–C