

Module 6

(Lecture 20 to 23)

LATERAL EARTH PRESSURE

Topics

20.1 INTRODUCTION

20.2 LATERAL EARTH PRESSURE AT REST

20.3 ACTIVE PRESSURE

20.4 RANKINE ACTIVE EARTH PRESSURE

20.5 Example

**20.6 RANKINE ACTIVE EARTH PRESSURE FOR
INCLINED BACKFILL**

21.1 COULOMB'S ACTIVE EARTH PRESSURE

**21.2 ACTIVE EARTH PRESSURE FOR EARTHQUAKE
CONDITIONS**

22.1 LATERAL EARTH PRESSURE

**22.2 LATERAL EARTH PRESSURE DUE TO
SURCHARGE**

**22.3 ACTIVE PRESSURE FOR WALL ROTATION
ABOUT TOP-BRACED CUT**

**22.4 ACTIVE EARTH PRESSURE FOR TRANSLATION
OF RETAINING WALL-GRANULAR BACKFILL**

23.1 PASSIVE PRESSURE

23.2 RANKINE PASSIVE EARTH PRESSURE

**23.3 RANKINE PASSIVE EARTH PRESSURE-
INCLINED BACKFILL**

23.4 COULOMB'S PASSIVE EARTH PRESSURE
23.5 COMMENTS ON THE FAILURE SURFACE
ASSUMPTION FOR COULOMB'S PRESSURE
CALCULATIONS

PROBLEMS
REFERENCE

Module 6

(Lecture 20)

LATERAL EARTH PRESSURE

Topics

1.1 INTRODUCTION

1.2 LATERAL EARTH PRESSURE AT REST

1.3 ACTIVE PRESSURE

1.4 RANKINE ACTIVE EARTH PRESSURE

1.5 Example

**1.6 RANKINE ACTIVE EARTH PRESSURE FOR
INCLINED BACKFILL**

INTRODUCTION

Vertical or near vertical slopes of soil are supported by retaining walls, cantilever sheet-pile walls, sheet-pile bulkheads, braced cuts, and other similar structures. The proper design of those structures required estimation of lateral earth pressure, which is a function of several factors, such as (a) type and amount of wall movement, (b) shear strength parameters of the soil, (c) unit weight of the soil, and (d) drainage conditions in the backfill. **Figure 6.1** shows a retaining wall of height H . for similar types of backfill.

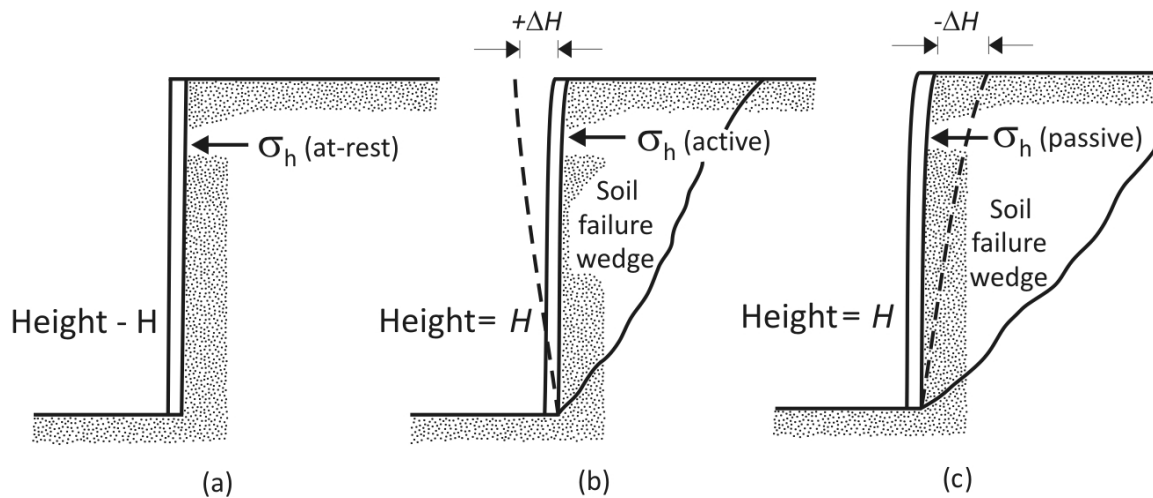

Figure 6.1 Nature of lateral earth pressure on a retaining wall

- The wall may be restrained from moving (figure 6.1a). The lateral earth pressure on the wall at any depth is called the at-rest earth pressure.
- The wall may tilt away from the soil retained (figure 6.1b). With sufficient wall tilt, a triangular soil wedge behind the wall will fail. The lateral pressure for this condition is referred to as active earth pressure.
- The wall may be pushed into the soil retained (figure 6.1c). With sufficient wall movement, a soil wedge will fail. The lateral pressure for this condition is referred to as passive earth pressure.

Figure 6.2 Shows the nature of variation of the lateral pressure (σ_h) at a certain depth of the wall with the magnitude of wall movement.

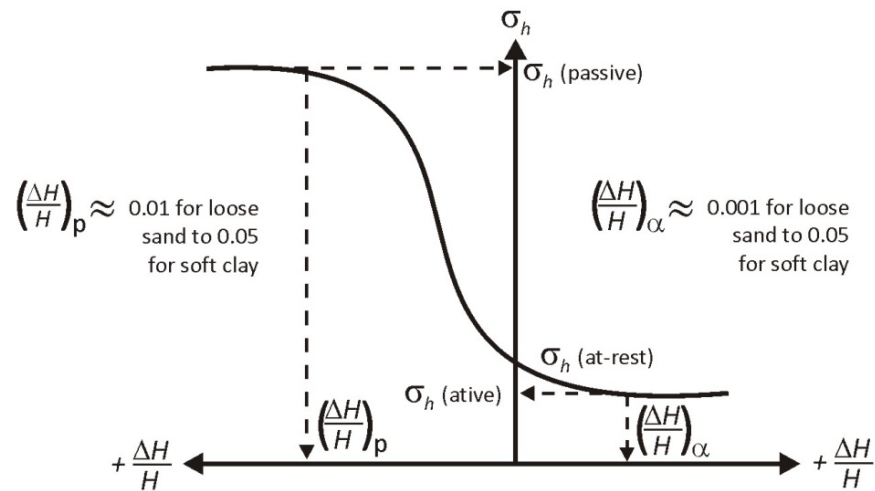

Figure 6.2 Nature of variation of lateral earth pressure at a certain depth

In the following sections we will discuss various relationships to determine the at-rest, active, and passive pressures on a retaining wall. It is assumed that the readers have been exposed to lateral earth pressure in the past, so this chapter will serve as a review.

LATERAL EARTH PRESSURE AT REST

Consider a vertical wall of height H , as shown in **figure 6.3**, retaining a soil having a unit weight of γ . A uniformly distributed load, q /unit area, is also applied at the ground surface. The shear strength, s , of the soil is

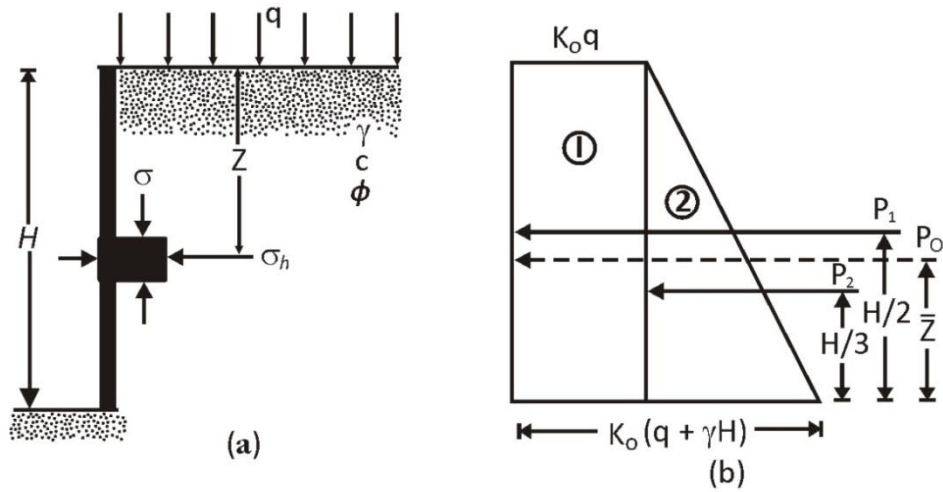

Figure 6.3 At-rest earth pressure

$$s = c + \sigma' \tan \phi$$

Where

c = cohesion

ϕ = angle of friction

σ' = effective normal stress

At any depth z below the ground surface, the vertical subsurface stress is

$$\sigma_v = q + \gamma z \quad [6.1]$$

If the wall is at rest and is not allowed to move at all either away from the soil mass or into the soil mass (e.g., zero horizontal strain), the lateral pressure at a depth z is

$$\sigma_h = K_o \sigma'_v + u \quad [6.2]$$

Where

u = pore water pressure

K_o = coefficient of at – rest earth pressure

For normally consolidated soil, the relation for K_o (Jaky, 1944) is

$$K_o \approx 1 - \sin \phi \quad [6.3]$$

Equation 3 is an empirical approximation.

For normally consolidated clays, the coefficient of earth pressure at rest can be approximated (Brooker and Ireland, 1965) as

$$K_o \approx 0.95 - \sin \phi \quad [6.4]$$

Where

ϕ = drained peak friction angle

Based on Brooker and Ireland's (1965) experimental results, the value of K_o for normally consolidated clays may be approximated correlated with the plasticity index (PI):

$$K_o = 0.4 + 0.007 (PI) \quad (\text{for } PI \text{ between } 0 \text{ and } 40) \quad [6.5]$$

And

$$K_o = 0.64 + 0.001 (PI) \quad (\text{for } PI \text{ between } 40 \text{ and } 80) \quad [6.6]$$

For overconsolidated clays,

$$K_{o(\text{overconsolidated})} \approx K_{o(\text{normally consolidated})} \sqrt{OCR} \quad [6.7]$$

Where

OCR = overconsolidation ratio

Mayne and Kulhawy (1982) analyzed the results of 171 different laboratory tested soils. Based on this study, they proposed a general empirical relationship to estimate the magnitude of K_o for sand and clay:

$$K_o = (1 - \sin \phi) \left[\frac{OCR}{OCR_{\max}^{(1-\sin \phi)}} + \frac{3}{4} \left(1 - \frac{OCR}{OCR_{\max}} \right) \right] \quad [6.8]$$

Where

OCR = present overconsolidation ratio

OCR_{\max} = maximum overconsolidation ratio

In **figure 6.4**, OCR_{\max} is the value of OCR at point B .

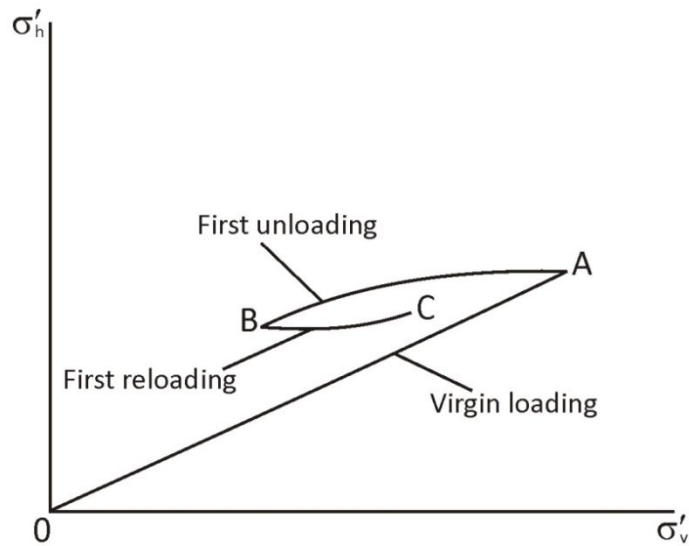
 Figure 6.4 Stress history for soil under K_o condition

With a properly selected value of the at-rest earth pressure coefficient, equation (2) can be used to determine the variation of lateral earth pressure with depth z . Figure 6.3b shows the variation of σ_h with depth for the wall shown in figure 6.3a. Note that if the surcharge $q = 0$ and the pore water pressure $u = 0$, the pressure diagram will be a triangle. The total force, P_o , per unit length of the wall given in figure 6.3a can now be obtained from the area of the pressure diagram given in figure 6.3b as

$$P_o = P_1 + P_2 = qK_o H + \frac{1}{2}\gamma H^2 K_o \quad [6.9]$$

Where

P_1 = area of rectangle 1

P_2 = area of triangle 2

The location of the line of action of the resultant force, P_o , can be obtained by taking the moment about the bottom of the wall. Thus

$$\bar{z} = \frac{P_1\left(\frac{H}{2}\right) + P_2\left(\frac{H}{3}\right)}{P_o} \quad [6.10]$$

If the water table is located at depth $z < H$, the at-rest pressure diagram shown in figure 6.3b will have to be somewhat modified, as shown in **figure 6.5**. If the effective unit weight of soil below the water table equal γ' (that is, $\gamma_{\text{sat}} - \gamma_w$),

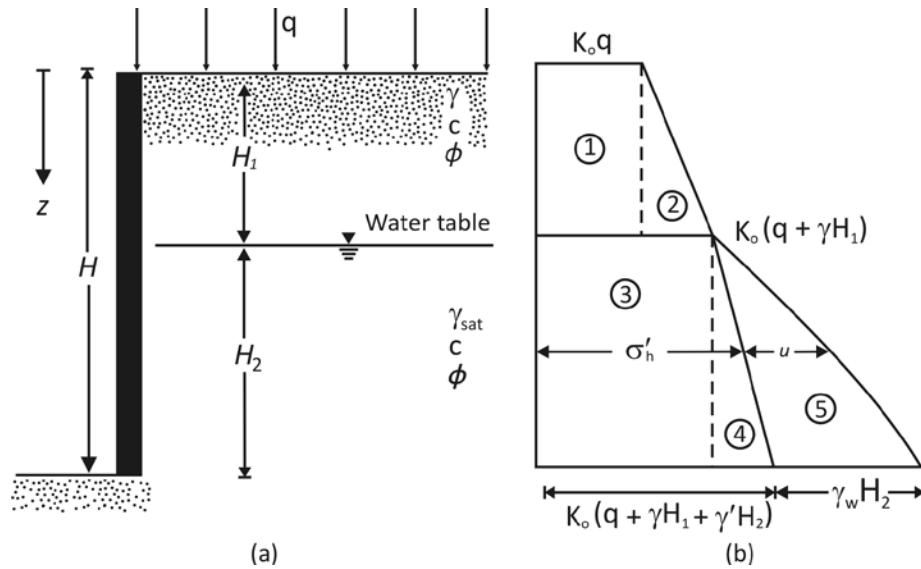

Figure 6.5

$$\text{At } z = 0, \sigma'_h = K_o \sigma'_v = K_o q$$

$$\text{At } z = H_1, \sigma'_h = K_o \sigma'_v = K_o (q + \gamma H_1)$$

$$\text{At } z = H_2, \sigma'_h = K_o \sigma'_v = K_o (q + \gamma H_1 + \gamma' H_2)$$

Note that in the preceding equations, σ'_v and σ'_h are effective vertical and horizontal pressures. Determining the total pressure distribution on the wall requires adding the hydrostatic pressure. The hydrostatic pressure, u , is zero from $z = 0$ and $z = H_1$; at $z = H_2$, $u = H_2 \gamma_w$. The variation of σ'_h and u with depth is shown in figure 6.5b. Hence the total force per unit length of the wall can be determined from the area of the pressure diagram. Thus

$$P_o = A_1 + A_2 + A_3 + A_4 + A_5$$

Where

A = area of the pressure diagram

So

$$P_o = K_o q H_1 + \frac{1}{2} K_o \gamma H_1^2 + K_o (q + \gamma H_1) H_2 + \frac{1}{2} K_o \gamma' H_2^2 + \frac{1}{2} \gamma_w H_2^2 \quad [6.11]$$

Sheriff et al. (1984) showed by several laboratory model tests that equation (3) gives good results for estimating the lateral earth pressure at rest for loose sands. However, for compacted dense sand, it grossly underestimates the value of K_o . For that reason, they proposed a modified relationship for K_o :

$$K_o = (1 - \sin \phi) + \left(\frac{\gamma_d}{\gamma_{d(\min)}} - 5 \right) 5.5 \quad [6.12]$$

Where

$\gamma_d = in\ situ$ unit weight of sand

$\gamma_{d(\min)}$ = minimum possible dry unit weight of sand (see chapter 1)

Example 1

For the retaining wall shown in **figure 6.6(a)**, determine the lateral earth fore at rest per unit length of the wall. Also determine the location of the resultant force.

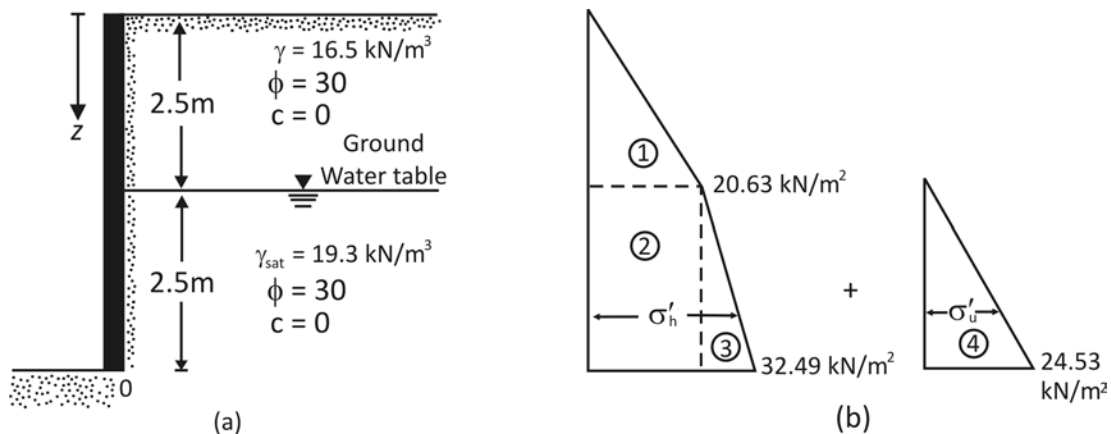

Figure 6.6

Solution

$$K_o = 1 - \sin \phi = 1 - \sin 30^\circ = 0.5$$

$$\text{At } z = 0, \sigma'_v = 0; \sigma'_h = 0$$

$$\text{At } z = 2.5 \text{ m, } \sigma'_v = (16.5)(2.5) = 41.25 \text{ kN/m}^2;$$

$$\sigma'_h = K_o \sigma'_v = (0.5)(41.25) = 20.63 \text{ kN/m}^2$$

$$\text{At } z = 5 \text{ m, } \sigma'_v = (16.5)(2.5) + (19.3 - 9.81)2.5 = 64.98 \text{ kN/m}^2;$$

$$\sigma'_h = K_o \sigma'_v = (0.5)(64.98) = 32.49 \text{ kN/m}^2$$

The hydrostatic pressure distribution is as follows:

From $z = 0$ to $z = 2.5$ m, $u = 0$. At $z = 5$ m, $u = \gamma_w(2.5) = (9.81)(2.5) = 24.53$ kN/m². The pressure distribution for the wall is shown in figure 6.6b.

The total force per unit length of the wall can be determined from the area of the pressure diagram, or

$$P_o = \text{Area 1} + \text{Area 2} + \text{Area 3} + \text{Area 4}$$

$$= \frac{1}{2}(2.5)(20.63) + (2.5)(20.63) + \frac{1}{2}(2.5)(32.49 - 20.63) + \frac{1}{2}(2.5)(24.53) = 122.85 \text{ kN/m}$$

The location of the center of pressure measured from the bottom of the wall (Point O) =

$$\begin{aligned} \bar{z} &= \frac{(\text{Area 1})\left(2.5 + \frac{2.5}{3}\right) + (\text{Area 2})\left(\frac{2.5}{2}\right) + (\text{Area 3} + \text{Area 4})\left(\frac{2.5}{3}\right)}{P_o} \\ &= \frac{(25.788)(3.33) + (51.575)(1.25) + (14.825 + 30.663)(0.833)}{122.85} \\ &= \frac{85.87 + 64.47 + 37.89}{122.85} = 1.53 \text{ m} \end{aligned}$$

ACTIVE PRESSURE

RANKINE ACTIVE EARTH PRESSURE

The lateral earth pressure conditions described in section 2 involve walls that do not yield at all. However, if a wall tends to move away from the soil a distance Δx , as shown in **figure 6.7a**, the soil pressure on the wall at any depth will decrease. For a wall that is *frictionless*, the horizontal stress, σ_h , at depth z will equal $K_o \sigma_v$ ($K_o \gamma z$) when Δx is zero. However, with $\Delta x > 0$, σ_h will be less than $K_o \sigma_v$.

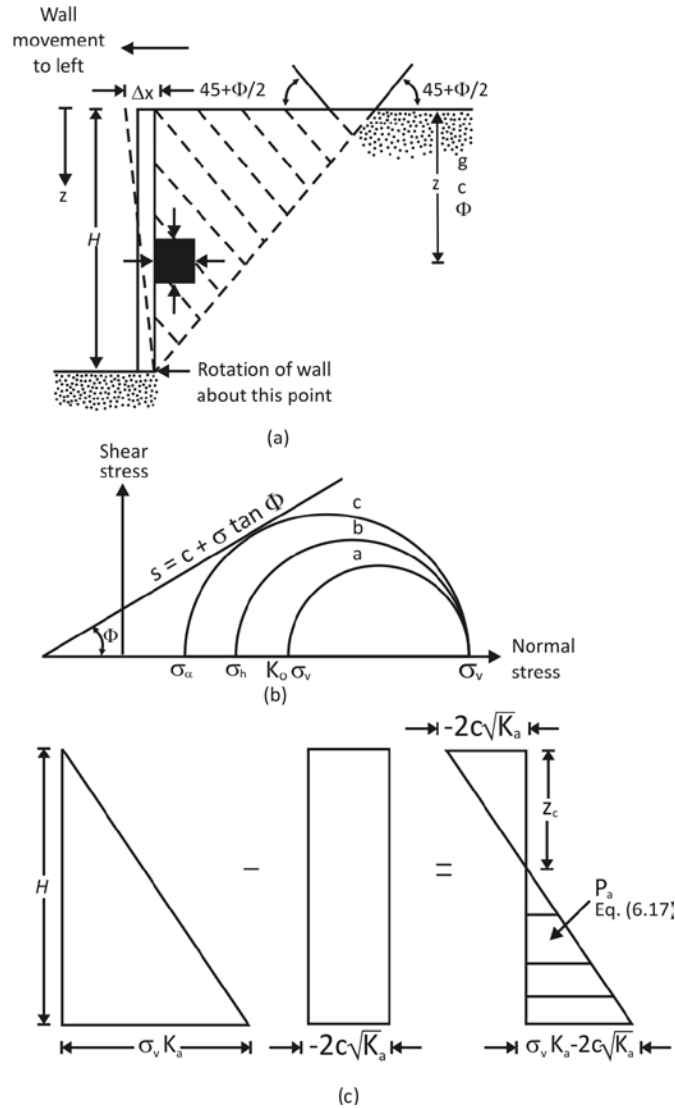

Figure 6.7 Rankine active pressure

The Mohr's circles corresponding to wall displacements of $\Delta x = 0$ and $\Delta x > 0$ are shown as circles *a* and *b*, respectively, in **figure 6.7b**. If the displacement of the wall, Δx , continues to increase, the corresponding Mohr's circle eventually will just touch the Mohr-Coulomb failure envelope defined by the equation

$$s = c + \sigma \tan \phi$$

This circle is marked *c* in figure 6.7b. It represents the failure condition in the soil mass; the horizontal stress then equals σ_a . This horizontal stress, σ_a , is referred to as the *Rankin active pressure*. The *slip lines* (failure planes) in the soil mass will then make angles of $\pm(45 + \phi/2)$ with the horizontal, as shown in figure 6.7a.

Refer back to equation (84 from chapter 1) the equation relating the principal stresses for a Mohr's circle that touches the Mohr-Coulomb failure envelope:

$$\sigma_1 = \sigma_3 \tan^2 \left(45 + \frac{\phi}{2} \right) + 2c \tan \left(45 + \frac{\phi}{2} \right)$$

For the Mohr's circle c in figure 6.7b,

Major Principal stress, $\sigma_1 = \sigma_v$

And

Minor Principal stress, $\sigma_3 = \sigma_a$

Thus

$$\sigma_v = \sigma_a \tan^2 \left(45 + \frac{\phi}{2} \right) + 2c \tan \left(45 + \frac{\phi}{2} \right)$$

$$\sigma_a = \frac{\sigma_v}{\tan^2 \left(45 + \frac{\phi}{2} \right)} - \frac{2c}{\tan \left(45 + \frac{\phi}{2} \right)}$$

Or

$$\sigma_a = \sigma_v \tan^2 \left(45 + \frac{\phi}{2} \right) - 2c \tan \left(45 - \frac{\phi}{2} \right)$$

$$= \sigma_v K_a - 2c \sqrt{K_a} \quad [6.13]$$

Where

$K_o = \tan^2(45 - \phi/2) =$ Rankine active pressure coefficient (table 1)

The variation of the active pressure with depth for the wall shown in figure 6.7a is given in figure 6.7c. Note that $\sigma_v = 0$, at $z = 0$ and $\sigma_v = \gamma H$ at $z = H$. The pressure distribution shows that at $z = 0$ the active pressure equals $-2c\sqrt{K_a}$ indicating tensile stress. This tensile stress decreases with depth and becomes zero at a depth $z = z_c$, or

$$\gamma z_c K_a - 2c \sqrt{K_a} = 0$$

And

$$z_c = \frac{2c}{\gamma \sqrt{K_a}} \quad [6.14]$$

The depth z_c is usually referred to as the *depth of tensile crack*, because the tensile stress in the soil will eventually cause a crack along the soil-wall interface. Thus the total Rankine active force per unit length of the wall before the tensile crack occurs is

$$P_a = \int_0^H \sigma_a dz = \int_0^H \gamma z K_a dz - \int_0^H 2c \sqrt{K_a} dz$$

$$= \frac{1}{2}\gamma H^2 K_a - 2cH\sqrt{K_a} \quad [6.15]$$

Table 1 Variation of Rankine K_a

Soil friction angle, ϕ (deg)	$K_a = \tan^2(45 - \phi/2)$
20	0.490
21	0.472
22	0.455
23	0.438
24	0.422
25	0.406
26	0.395
27	0.376
28	0.361
29	0.347
30	0.333
31	0.320
32	0.307
33	0.295
34	0.283
35	0.271
36	0.260
37	0.249
38	0.238
39	0.228

40	0.217
41	0.208
42	0.198
43	0.189
44	0.180
45	0.172

After the occurrence of the tensile crack, the force on the wall will be caused only by the pressure distribution between depths $z = z_c$ and $z = H$, as shown by the hatched area in figure 6.7c. It may be expressed as

$$P_a = \frac{1}{2}(H - z_c)(\gamma H K_a - 2c\sqrt{K_a}) \quad [6.16]$$

Or

$$P_a = \frac{1}{2}\left(H - \frac{2c}{\gamma\sqrt{K_a}}\right)(\gamma H K_a - 2c\sqrt{K_a}) \quad [6.17]$$

For calculation purposes in some retaining wall design problems, a cohesive soil backfill is replaced by an assumed granular soil with a triangular Rankine active pressure diagram with $\sigma_a = 0$ at $z = 0$ and $\sigma_a = \sigma_v K_a - 2c\sqrt{K_a}$ at $z = H$ (see **figure 6.8**). In such a case, the assumed active force per unit length of the wall is

$$P_a = \frac{1}{2}(\gamma H K_a - 2c\sqrt{K_a}) = \frac{1}{2}\gamma H^2 K_a - cH\sqrt{K_a} \quad [6.18]$$

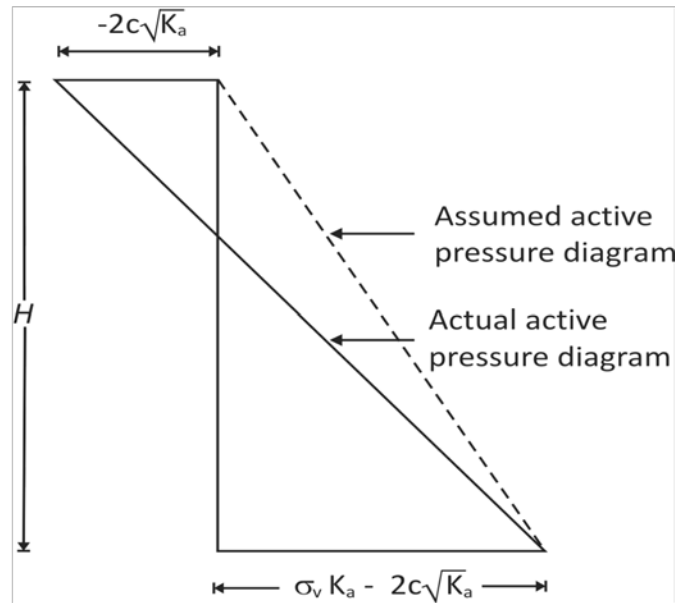

Figure 6.8 Assumed active pressure diagram for clay backfill behind a retaining wall

However, the active earth pressure condition will be reached only if the wall is allowed to “yield” sufficiently. The amount of outward displacement of the wall necessary is about $0.001H$ to $0.004H$ for granular soil backfills and about $0.01H$ to $0.04H$ for cohesive soil backfills.

Example 2

A 6-m-high retaining wall is to support a soil with unit weight $\gamma = 17.4 \text{ kN/m}^3$, soil friction angle $\phi = 26^\circ$, and cohesion $c = 14.36 \text{ kN/m}^2$. Determine the Rankine active force per unit length of the wall both before and after the tensile crack occurs, and determine the line of action of the resultant in both cases.

Solution

For $\phi = 26^\circ$,

$$K_a = \tan^2 \left(45 - \frac{\phi}{2} \right) = \tan^2(45 - 13) = 0.39$$

$$\sqrt{K_a} = 0.625$$

$$\sigma_a = \gamma H K_a - 2c\sqrt{K_a}$$

Refer to figure 6.7c:

$$\text{At } z = 0, \sigma_a = -2c\sqrt{K_a} = -2(14.36)(0.625) = -17.95 \text{ kN/m}^2$$

$$\text{At } z = 6 \text{ m, } \sigma_a = (17.4)(6)(0.39) - 2(14.36)(0.625) = 40.72 - 17.95 = 22.77 \text{ kN/m}^2$$

Active Force Before the Occurrence of Tensile Crack: equation (15)

$$P_a = \frac{1}{2}(\gamma H^2 K_a - 2cH\sqrt{K_a})$$

$$= \frac{1}{2}(6)(40.72) - (6)(17.95) = 122.16 - 107.7 = 14.46 \text{ kN/m}$$

The line of action of the resultant can be determined by taking the moment of the area of the pressure diagrams about the bottom of the wall, or

$$P_a \bar{z} = (122.16)\left(\frac{6}{3}\right) - (107.7)\left(\frac{6}{2}\right)$$

Or

$$\bar{z} = \frac{244.32 - 323.1}{14.46} = -5.45 \text{ m}$$

Active Force After the Occurrence of Tensile Crack: equation (14)

$$z_c = \frac{2c}{\gamma\sqrt{K_a}} = \frac{2(14.36)}{(17.4)(0.625)} = 2.64 \text{ m}$$

Using equation (16) gives

$$P_a = \frac{1}{2}(H - z_c)\gamma H K_a - 2c\sqrt{K_a} = \frac{1}{2}(6 - 2.64)(22.77) = 38.25 \text{ kN/m}$$

Figure 6.7c shows that the force $P_a = 38.25 \text{ kN/m}$ is the area of the hatched triangle. Hence the line of action of the resultant will be located at a height of $\bar{z} = (H - z_c)/3$ above the bottom of the wall, or

$$\bar{z} = \frac{6 - 2.64}{3} = 1.12 \text{ m}$$

For most retaining wall construction, a granular backfill is used and $c = 0$. Thus example 2 is an academic problem; however, it illustrates the basic principles of the Rankine active earth pressure calculation.

Example 3

For the retaining wall shown in **figure 6.9a**, assume that the wall can yield sufficiently to develop active state. Determine the Rankine active force per unit length of the wall and the location of the resultant line of action.

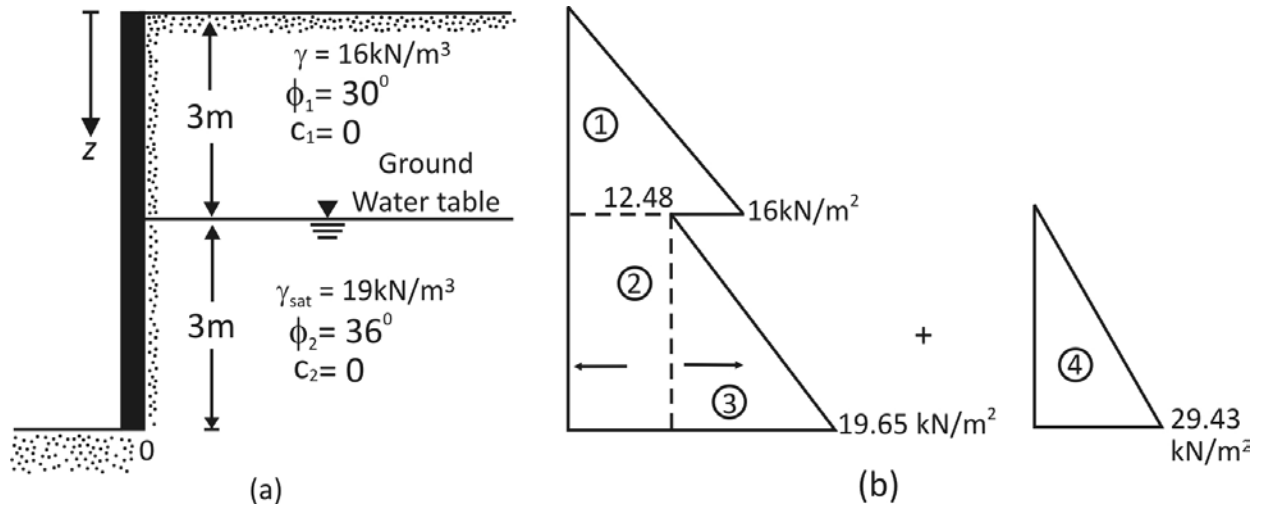

Figure 6.9

Solution

If the cohesion, c , is equal to zero

$$\sigma'_a = \sigma'_v K_a$$

For the top soil layer, $\phi_1 = 30^\circ$, so

$$K_{a(1)} = \tan^2 \left(45 - \frac{\phi_1}{2} \right) = \tan^2 (45 - 15) = \frac{1}{3}$$

Similarly, for the bottom soil layer, $\phi_2 = 36^\circ$, and

$$K_{a(2)} = \tan^2 \left(45 - \frac{36}{2} \right) = 0.26$$

Because of the presence of the water table, the effective lateral pressure and the hydrostatic pressure have to be calculated separately.

$$\text{At } z = 0, \sigma'_v = 0, \sigma'_a = 0$$

$$\text{At } z = 3 \text{ m, } \sigma'_v = \gamma z = (16)(3) = 48 \text{ kN/m}^2$$

At this depth, for the top soil layer

$$\sigma'_a = K_{a(1)} \sigma'_v = \left(\frac{1}{3} \right) (48) = 16 \text{ kN/m}^2$$

Similarly, for the bottom soil layer

$$\sigma'_a = K_{a(2)} \sigma'_v = (0.26)(48) = 12.48 \text{ kN/m}^2$$

$$\text{At } z = 6 \text{ m, } \sigma'_v = (\gamma)(3) + (\gamma_{\text{sat}} - \gamma_w)(3) = (16)(3) + (19 - 9.81)(3)$$

$$= 48 + 27.57 = 75.57 \text{ kN/m}^2$$

$$\sigma'_a = K_{a(2)}\sigma'_v = (0.26)(75.57) = 19.65 \text{ kN/m}^2$$

The hydrostatic pressure, u , is zero from $z = 0$ to $z = 3$ m. At $z = 6$ m, $u = 3\gamma_w = 3(9.81) = 29.43 \text{ kN/m}^2$. The pressure distribution diagram is plotted in figure 6.9b. The force per unit length

$$P_a = \text{Area 1} + \text{Area 2} + \text{Area 3} + \text{Area 4}$$

$$= \frac{1}{2}(3)(16) + (12.48) + \frac{1}{2}(3)(19.65 - 12.48) + \frac{1}{2}(3)(29.43)$$

$$= 24 + 37.44 + 10.76 + 44.15 = 116.35 \text{ kN/m}$$

The distance of the line of action of the resultant from the bottom of the wall (\bar{z}) can be determined by taking the moments about the bottom of the wall (point O in figure 6.9a), or

$$\begin{aligned} \bar{z} &= \frac{(24)\left(3+\frac{3}{3}\right)+(37.44)\left(\frac{3}{2}\right)+(10.76)\left(\frac{3}{3}\right)+(44.15)\left(\frac{3}{3}\right)}{116.35} \\ &= \frac{96+56.16+10.76+44.15}{116.35} = 1.78 \text{ m} \end{aligned}$$

Example 4

Refer to example 3. Other quantities remaining the same, assume that, in the top layer, $c_1 = 24 \text{ kN/m}^2$ (not zero as in example 3). Determine P_a after the occurrence of the tensile crack.

Solution

From equation (14)

$$z_c = \frac{2c_1}{\gamma\sqrt{K_{a(1)}}} = \frac{(2)(24)}{(16)\sqrt{\left(\frac{1}{2}\right)}} = 5.2 \text{ m}$$

Since the depth of the top layer is only 3 m, the depth of the tensile crack will be only 3 m. so the pressure diagram up to $z = 3$ m will be zero. For $z > 3$ m, the pressure diagram will be the same as shown in figure 6.9, or

$$P_a = \underbrace{\text{Area 2} + \text{Area 3} + \text{Area 4}}_{\text{Figure 6.9}}$$

$$= 37.44 + 10.76 + 44.15 = 92.35 \text{ kN/m}$$

RANKINE ACTIVE EARTH PRESSURE FOR INCLINED BACKFILL

If the backfill of a frictionless retaining wall is a *granular soil* ($c = 0$) and rises at an angle α with respect to the horizontal (**figure 6.10**), the *active earth pressure coefficient*, K_a , may be expressed in the form

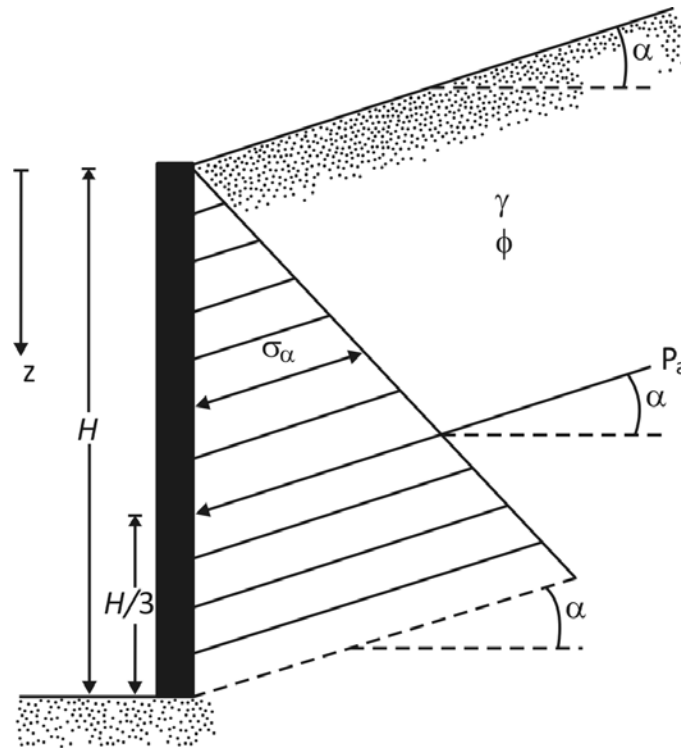

Figure 6.10 Notations for active pressure-equations (19, 20, 21)

$$K_a = \cos \alpha \frac{\cos \alpha - \sqrt{\cos^2 \alpha - \cos^2 \phi}}{\cos \alpha + \sqrt{\cos^2 \alpha - \cos^2 \phi}} \quad [6.19]$$

Where

ϕ = angle of friction of soil

At any depth, z , the *Rankine active pressure* may be expressed as

$$\sigma_a = \gamma z K_a \quad [6.20]$$

Also, the total force per unit length of the wall is

$$P_a = \frac{1}{2} \gamma H^2 K_a \quad [6.21]$$

Note that, in this case, the direction of the resultant force, P_a , is *inclined at an angle α with the horizontal* and intersects the wall at a distance of $H/3$ from the base of the wall. Table 2 presents the values of K_a (active earth pressure) for various values of α and ϕ .

The preceding analysis can be extended for an inclined backfill with a $c - \phi$ soil. The details of the mathematical derivation are given by Mazindrani and Ganjali (1997). As in equation (20), for this case

$$\sigma_a = \gamma z K_a = \gamma z K'_a \cos \alpha \quad [6.22]$$

Table 2 Active Earth Pressure Coefficient, K_a [equation (19)]

		ϕ (deg)→					
↓ α (deg)	28	30	32	34	36	38	40
0	0.361	0.333	0.307	0.283	0.260	0.238	0.217
5	0.366	0.337	0.311	0.286	0.262	0.240	0.219
10	0.380	0.350	0.321	0.294	0.270	0.246	0.225
15	0.409	0.373	0.341	0.311	0.283	0.258	0.235
20	0.461	0.414	0.374	0.338	0.306	0.277	0.250
25	0.573	0.494	0.434	0.385	0.343	0.307	0.275

Table 3 Values of K'_a

		$\frac{c}{\gamma z}$			
ϕ (deg)	α (deg)	0.025	-0.05	0.1	0.5
15	0	0.550	0.512	0.435	-0.179
	5	0.566	0.525	0.445	-0.184
	10	0.621	0.571	0.477	-0.186
20	15	0.776	0.683	0.546	-0.196
	0	0.455	0.420	0.350	-0.210
	5	0.465	0.429	0.357	-0.212

	10	0.497	0.456	0.377	-0.218
	15	0.567	0.514	0.417	-0.229
25	0	0.374	0.342	0.278	-0.231
	5	0.381	0.348	0.283	-0.233
	10	0.402	0.366	0.296	-0.239
	15	0.443	0.401	0.321	-0.250
30	0	0.305	0.276	0.218	-0.244
	5	0.309	0.280	0.221	-0.246
	10	0.323	0.292	0.230	-0.252
	15	0.350	0.315	0.246	-0.263

Where

$$K'_a = \frac{1}{\cos^2 \phi} \left\{ \frac{2 \cos^2 \alpha + 2 \left(\frac{c}{\gamma z}\right) \cos \phi \sin \phi}{1 - \sqrt{\left[4 \cos^2 \alpha (\cos^2 \alpha - \cos^2 \phi) + 4 \left(\frac{c}{\gamma z}\right)^2 \cos^2 \phi + 8 \left(\frac{c}{\gamma z}\right) \cos^2 \alpha \sin \phi \cos \phi\right]}} \right\} \quad [6.23]$$

Some values of K'_a are given in table 3. For a problem of this type, the depth of tensile crack, z_c , is given as

$$z_c = \frac{2c}{\gamma} \sqrt{\frac{1 + \sin \phi}{1 - \sin \phi}} \quad [6.24]$$

Example 5

Refer to retaining wall shown in **figure 6.10**. Given: $H = 7.5 \text{ m}$, $\gamma = 18 \text{ kN/m}^3$, $\phi = 20^\circ$, $c = 13.5 \text{ kN/m}^2$, and $\alpha = 10^\circ$. Calculate the Rankine active force, P_a , per unit length of the wall and the location of the resultant after the occurrence of the tensile crack.

Solution

From equation (24),

$$z_c = \frac{2c}{\gamma} \sqrt{\frac{1+\sin \phi}{1-\sin \phi}} = \frac{(2)(13.5)}{18} \sqrt{\frac{1+\sin 20}{1-\sin 20}} = 2.14 \text{ m}$$

At $z = 7.5 \text{ m}$

$$\frac{c}{\gamma z} = \frac{13.5}{(18)(7.5)} = 0.1$$

From table 3, for 20° , $c/\gamma z = 0.1$ and $\alpha = 10^\circ$, the value of K'_a is 0.377, so at $z = 7.5 \text{ m}$

$$\sigma_a = \gamma z K'_a \cos \alpha = (18)(7.5)(0.377)(\cos 10) = 50.1 \text{ kN/m}^2$$

After the occurrence of the tensile crack, the pressure distribution on the wall will be as shown in **figure 6.11**, so

$$P_a = \left(\frac{1}{2}\right) (50.1)(7.5 - 2.14) = 134.3 \text{ kN/m}$$

$$\bar{z} = \frac{7.5 - 2.14}{3} = 1.79 \text{ m}$$

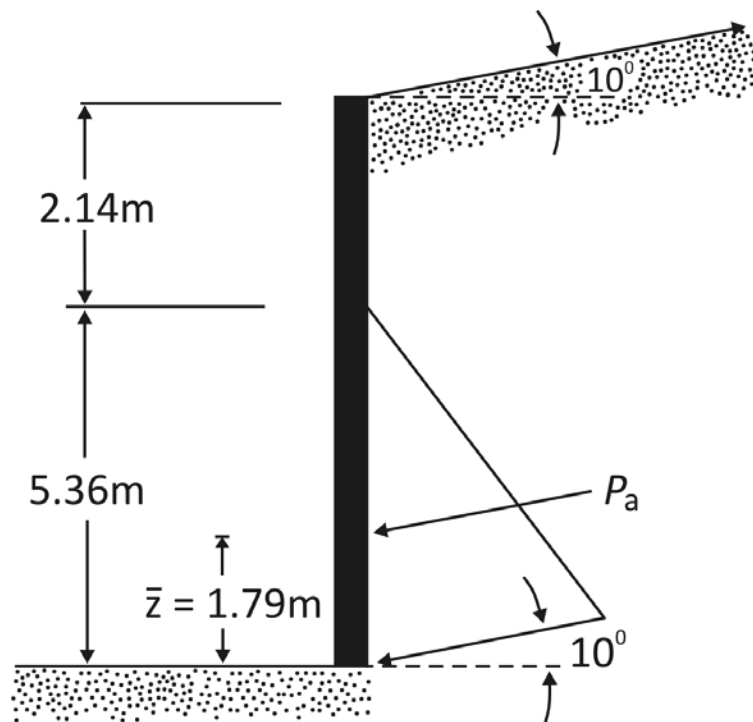

Figure 6.11