

Live Load Forces: Influence Lines for Determinate Structures

Introduction

Previous developments have been limited to structures subjected to fixed loads.

Structures are also subjected to live loads whose position may vary on the structure. This chapter focuses on such loads for statically determinate structures.

1

Influence Lines

Consider the bridge in Fig. 1. As the car moves across the bridge, the forces in the truss members change with the position of the car and the maximum force in each member will be at a different car location. The design of each member must be based on the maximum probable load each member will experience.

2

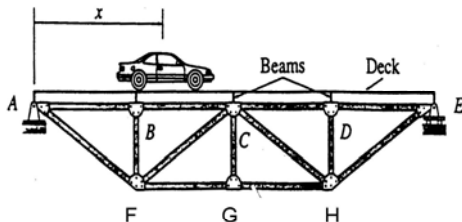

Figure 1. Bridge Truss Structure
Subjected to a Variable
Position Load

Therefore, the truss analysis for each member would involve determining the load position that causes the greatest force or stress in each member.

3

If a structure is to be safely designed, members must be proportioned such that the maximum force produced by dead and live loads is less than the available section capacity.

Structural analysis for variable loads consists of two steps:

1. Determining the positions of the loads at which the response function is maximum; and
2. Computing the maximum value of the response function.

4

See pages 49 - 77 in your class notes.

Influence Line Definitions

Response Function \equiv support reaction, axial force, shear force, or bending moment.

Influence Line \equiv graph of a response function of a structure as a function of the position of a downward unit load moving across the structure.

NOTE: Influence lines for statically determinate structures are always piecewise linear.

5

Once an influence line is constructed:

- Determine where to place live load on a structure to maximize the drawn response function; and
- Evaluate the maximum magnitude of the response function based on the loading.

6

Calculating Response Functions

(Equilibrium Method)

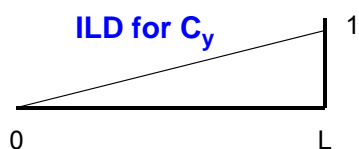
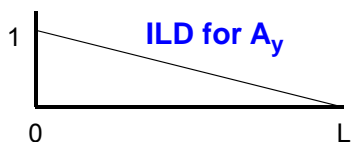
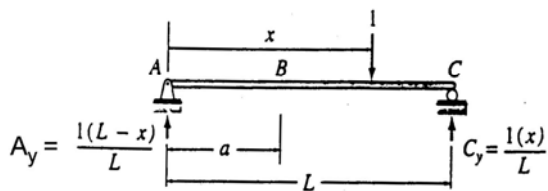

7

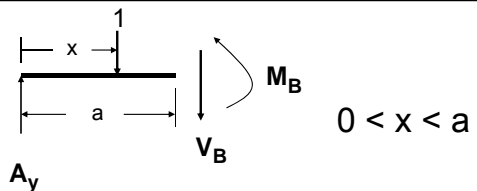

$$\sum F_y = 0 \Rightarrow V_B = A_y - 1$$

$$\sum M_a = 0 \Rightarrow M_B = A_y a - 1(a-x)$$

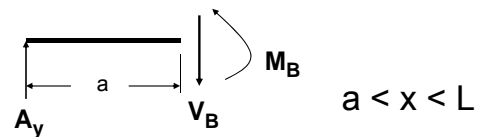

$$\sum F_y = 0 \Rightarrow V_B = A_y$$

$$\sum M_a = 0 \Rightarrow M_B = A_y a$$

8

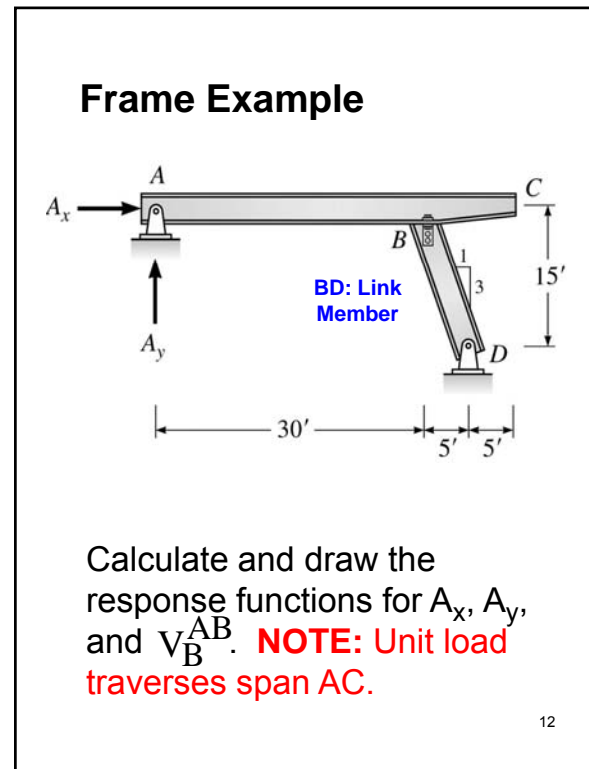
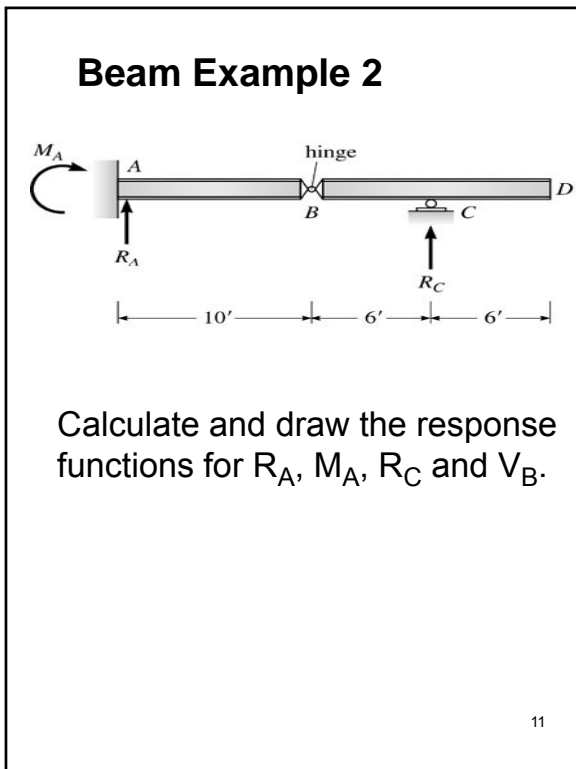
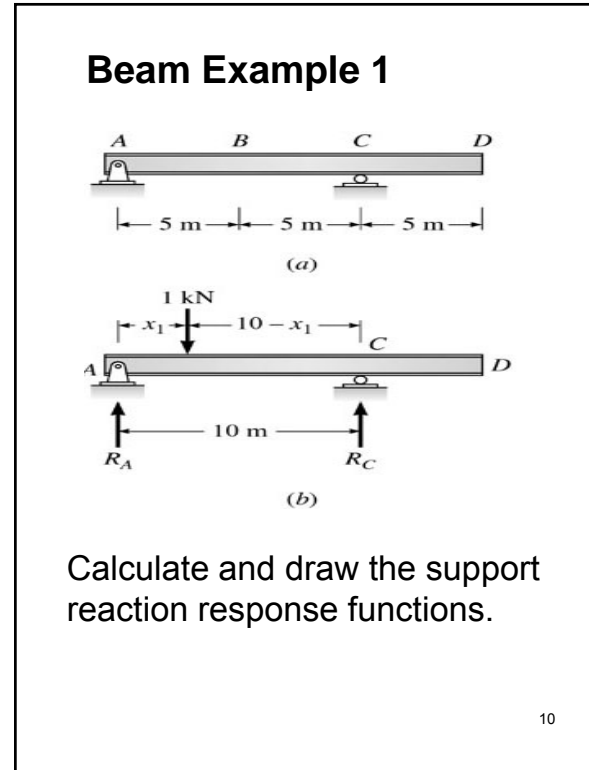
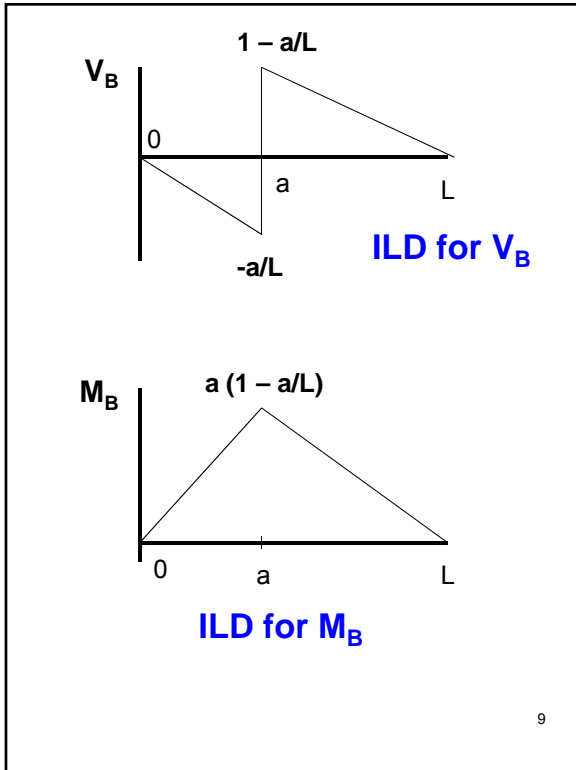

Muller-Breslau Principle

Muller-Breslau Principle \equiv The influence line for a response function is given by the deflected shape of the **released** structure due to a unit displacement (or rotation) at the location and in the direction of the response function.

A released structure is obtained by removing the displacement constraint corresponding to the response function of interest from the original structure.

13

CAUTION: Principle is only valid for force response functions.

Releases:

Support reaction - remove translational support restraint.

Internal shear - introduce an internal glide support to allow differential displacement movement.

Bending moment - introduce an internal hinge to allow differential rotation movement.

14

Copyright © The McGraw-Hill Companies, Inc. Permission required for reproduction or display.

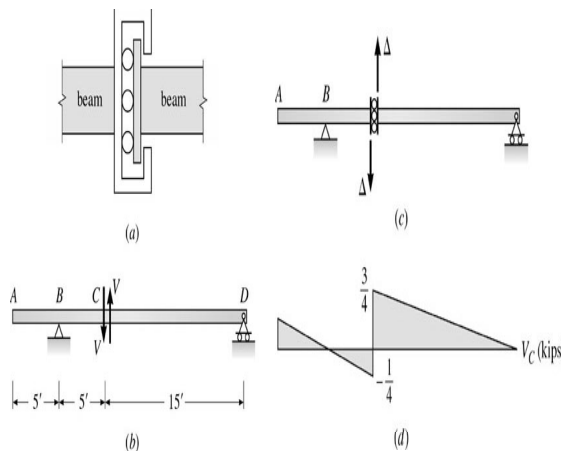

Influence Line for Shear

15

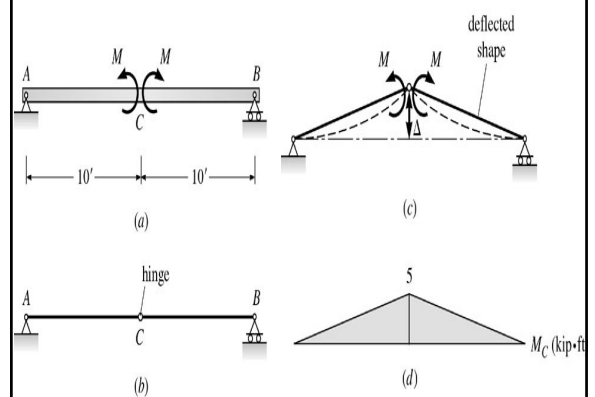

Influence Line for Bending Moment

16

Application of Muller-Breslau Principle

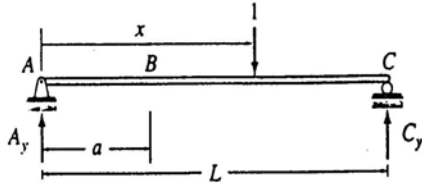

(a) Original Structure

17

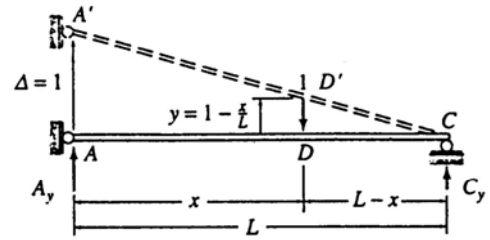

(b) Influence Line for A_y

18

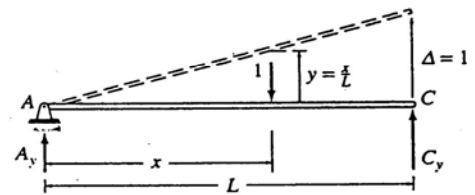

(c) Influence Line for C_y

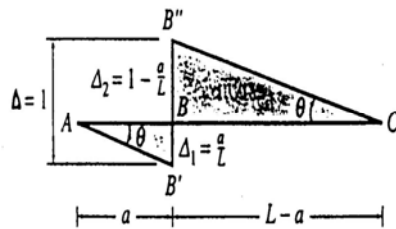
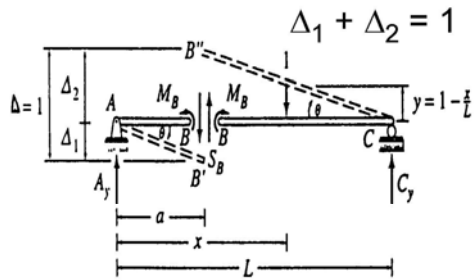

(d) Influence Line for S_B

19

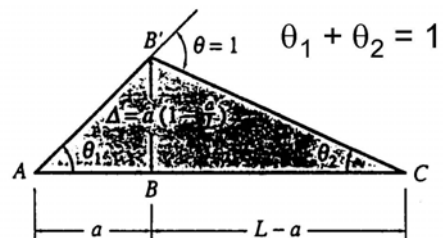
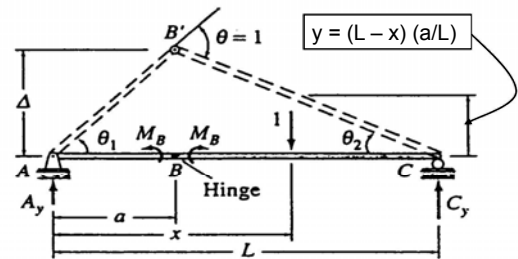

(e) Influence Line for M_B

20

Qualitative Influence Lines

In many practical applications, it is necessary to determine only the general shape of the influence lines but not the numerical values of the ordinates. Such an influence line diagram is known as a **qualitative influence line diagram**.

An influence line diagram with numerical values of its ordinates is known as a **quantitative influence line diagram**.

21

NOTE: An advantage of constructing influence lines using the Muller-Breslau Principle is that the response function of interest can be determined directly. It does not require determining the influence lines for other functions, as was the case with the equilibrium method.

22

Influence Lines for Trusses

In a gable-truss frame building, roof loads are usually transmitted to the top chord joints through roof purlins as shown in Fig. T.1.

Similarly, highway and railway bridge truss-structures transmit floor or deck loads via stringers to floor beams to the truss joints as shown schematically in Fig. T.2.

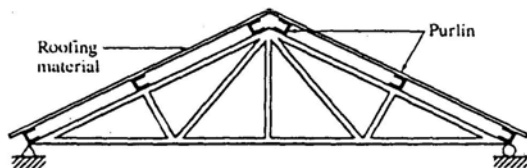

Fig. T.1. Gable Roof Truss

23

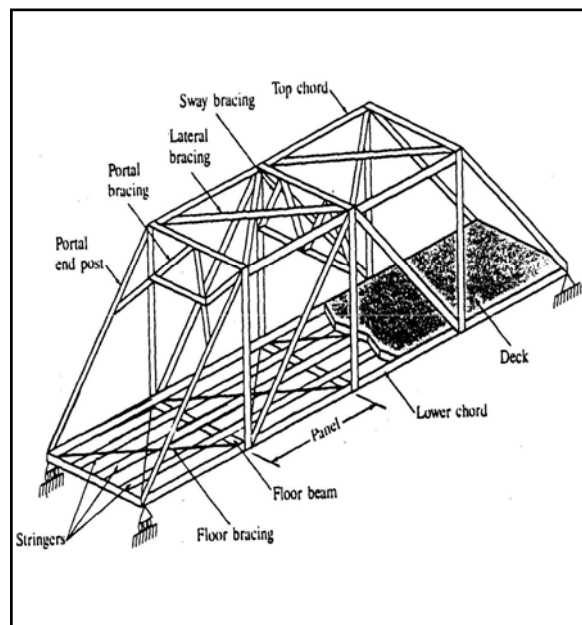

Fig. T.2. Bridge Truss

24

These load paths to the truss joints provide a reasonable assurance that the primary resistance in the truss members is in the form of axial force. **Consequently**, influence lines for axial member forces are developed by placing a unit load on the truss and making judicious use of free body diagrams and the equations of statics.

25

Due to the load transfer process in truss systems, no discontinuity will exist in the member force influence line diagrams. Furthermore, since we are restricting our attention to **statically determinate structures**, *the influence line diagrams will be piecewise linear.*

26

Example Truss Structure

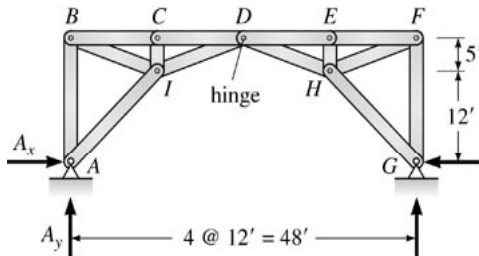

Calculate and draw the response functions for A_x , A_y , F_{CI} and F_{CD} .

27

Use of Influence Lines

Point Response Due to a Single Moving Concentrated Load

Each ordinate of an influence line gives the value of the response function due to a single concentrated load of unit magnitude placed on the structure at the location of that ordinate. Thus,

28

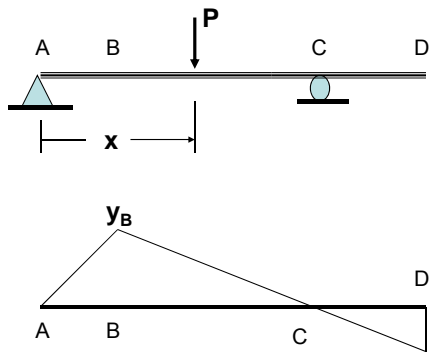

ILD for M_B

$$(M_B)_{\max}^+ \Rightarrow \text{place } P \text{ at } B$$

$$(M_B)_{\max}^- \Rightarrow \text{place } P \text{ at } D$$

29

1. The value of a response function due to any single concentrated load can be obtained by multiplying the magnitude of the load by the ordinate of the response function influence line at the position of the load.

2. Maximum positive value of the response function is obtained by multiplying the point load by the maximum positive ordinate. Similarly, the maximum negative value is obtained by multiplying the point load by the maximum negative ordinate.

30

Point Response Due to a Uniformly Distributed Live Load

Influence lines can also be employed to determine the values of response functions of structures due to distributed loads. This follows directly from point forces by treating the uniform load over a differential segment as a differential point force, i.e., $dP = w_\ell dx$. Thus, a response function R at a point can be expressed as

31

$$dR = dP y = w_\ell dx y$$

where y is the influence line ordinate at x , which is the point of application of dP .

To determine the total response function value at a point for a distributed load between $x = a$ to $x = b$, simply integrate:

$$R = \int_a^b w_\ell y dx = w_\ell \int_a^b y dx$$

32

in which the last integral expression represents the area under the segment of the influence line, which corresponds to the loaded portion of the beam.

SUMMARY

1. The value of a response function due to a uniformly distributed load applied over a portion of the structure can be obtained by multiplying the load intensity by the net area under the corresponding portion of the response function influence line.

33

2. To determine the maximum positive (or negative) value of a response function due to a uniformly distributed live load, the load must be placed over those portions of the structure where the ordinates of the response function influence line are positive (or negative).

Points 1 and 2 are schematically demonstrated on the next slide for moment M_B considered in the point load case.

34

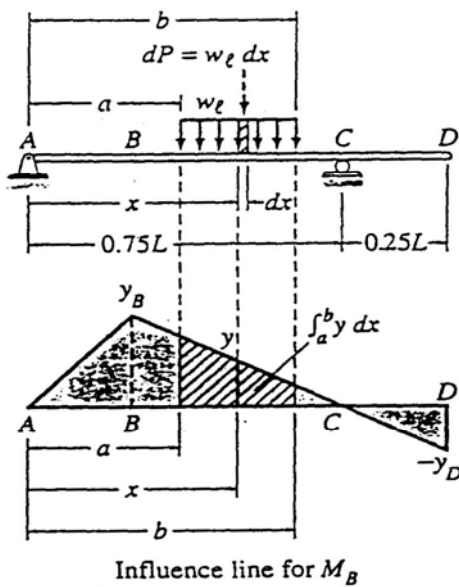

(a)

35

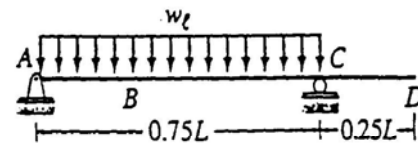

(b) Arrangement of Uniformly Distributed Live Load w_l for Maximum Positive M_B

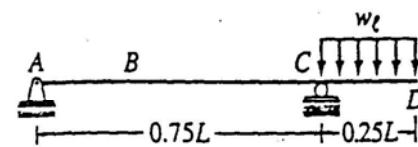

(c) Arrangement of Uniformly Distributed Live Load w_l for Maximum Negative M_B

36

Where should a **CLL** (Concentrated Live Load), a **ULL** (Uniform Live Load) and **UDL** (Uniform Dead Load) be placed on the typical ILD's shown below to maximize the response functions?

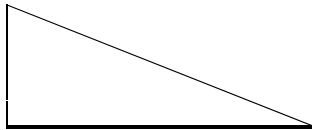

Typical End Shear (Reaction) ILD

37

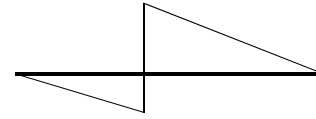

Typical Interior Beam Shear ILD

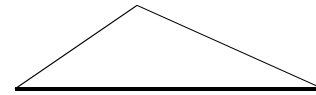

Typical Interior Bending Moment ILD

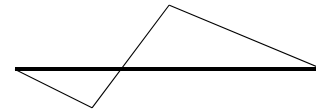

Possible Truss Member ILD

38

Live Loads for Highway and Railroad Bridges

Live loads due to vehicular traffic on highway and railway bridges are represented by a series of moving concentrated loads with specified spacing between the loads. In this section, we discuss the use of **influence lines to determine**: (1) the value of the response function for a given position of a series of concentrated loads and (2) the maximum value of the response function due to a series of moving concentrated loads.

39

To calculate the response function for a given position of the concentrated load series, simply multiply the value of each series load P_i by the magnitude of the influence line diagram ordinate y_i at the position of P_i , i.e.

$$R = \sum_i P_i y_i$$

The ordinate magnitude y_i can be calculated from the slope of the influence line diagram (m) via

$$y_i = m x_i$$

40

where x_i is the distance to point i measured from the zero y -axis intercept, as shown in the schematic ILD below.

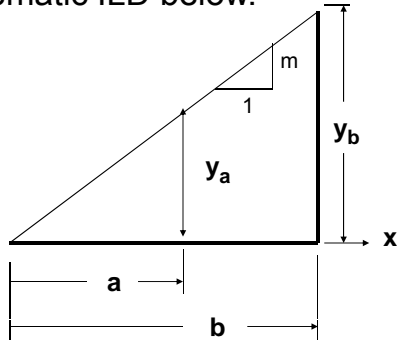

$$\frac{y_a}{a} = \frac{y_b}{b} \Rightarrow \text{similar triangles}$$

$$\therefore y_a = \frac{y_b}{b} a ; m = \frac{y_b}{b}$$

41

For example, consider the ILD shown on the next slide subjected to the given wheel loading:

Load Position 1:

$$\begin{aligned} V_{BI} &= 8\left(\frac{1}{30}20\right) + 10\left(\frac{1}{30}16\right) + 15\left(\frac{1}{30}13\right) + 5\left(\frac{1}{30}8\right) \\ &= \left(\frac{1}{30}\right)(8(20) + 10(16) + 15(13) + 5(8)) \\ &= m \sum_i P_i x_i = 18.5k \end{aligned}$$

42

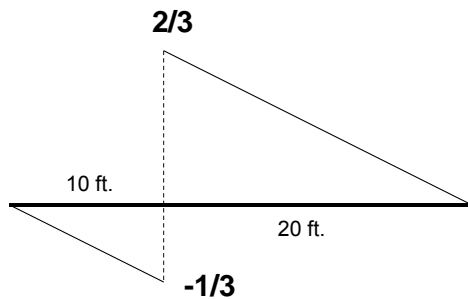

ILD for Internal Shear S_B

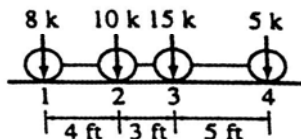

Wheel Loads

43

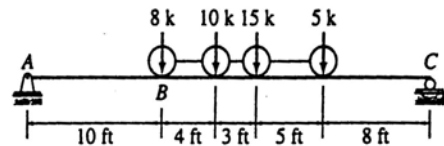

Position 1

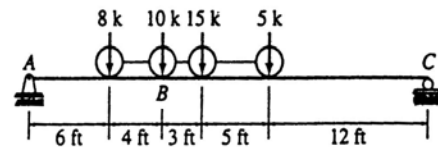

Position 2

44

Load Position 2:

$$V_{B2} = \frac{1}{30}(-8(6) + 10(20) + 15(17) + 5(12)) \\ = 15.6k$$

Thus, load position 1 results in the maximum shear at point B.

NOTE: If the arrangement of loads is such that all or most of the heavier loads are located near one of the ends of the series, then the analysis can be expedited by selecting a direction of movement for the series so that the heavier loads will reach the maximum

45

influence line ordinate before the lighter loads in the series. In such a case, it may not be necessary to examine all the loading positions. Instead, the analysis can be ended when the value of the response function begins to decrease; i.e., when the value of the response function is less than the preceding load position. This process is known as the **“Increase-Decrease Method”**.

46

CAUTION: This criterion is not valid for any general series of loads. In general, depending on the load magnitudes, spacing, and shape of the influence line, the value of the response function, after declining for some loading positions, may start increasing again for subsequent loading positions and may attain a higher maximum.

47

Zero Ordinate Location Linear Influence Line

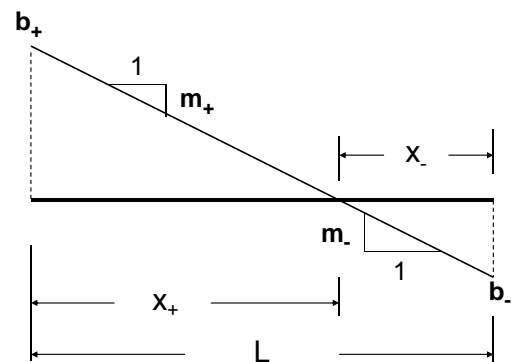

48

$$x_+ = \frac{-b_+}{m_+}; \quad m_+ = \frac{b_- - b_+}{L}$$

$$x_- = \frac{-b_-}{m_-}; \quad m_- = \frac{b_+ - b_-}{L}$$

NOTE: Both of these solutions are obtained from

$$y = mx + b$$

with $y = 0$.

49

Example Truss Problem: Application of Loads to Maximize Response

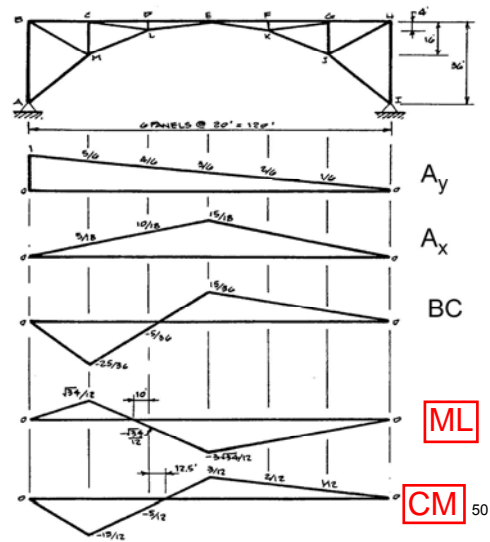

ML

CM 50

Also see page 69 in your class notes.

A larger version is on page 69a in your class notes.

Place

UDL = 1.0 k/ft;

ULL = 4.0 k/ft;

CLL = 20 kips

to maximize the tension and compression axial forces in members CM and ML.

Calculate the magnitudes of the tension and compression forces.

51

Force and Moment Envelopes

A plot of the maximum response function as a function of the location of the response function is referred to as the **envelope of the maximum values of a response function** for the particular load case being considered.

52

For a single concentrated force for a simply supported beam:

$$(V)_{\max}^+ = P \left(1 - \frac{a}{L}\right)$$

$$(V)_{\max}^- = -P \frac{a}{L}$$

$$M_{\max} = Pa \left(1 - \frac{a}{L}\right)$$

Plot is obtained by treating "a" as a variable.

53

For a uniformly distributed load on for a simply supported beam:

$$(V)_{\max}^+ = \frac{w_\ell}{2L} (L-a)^2$$

$$(V)_{\max}^- = -\frac{w_\ell a^2}{2L}$$

$$M_{\max} = \frac{w_\ell a}{2} (L-a)$$

Plot is obtained by treating "a" as a variable.

54

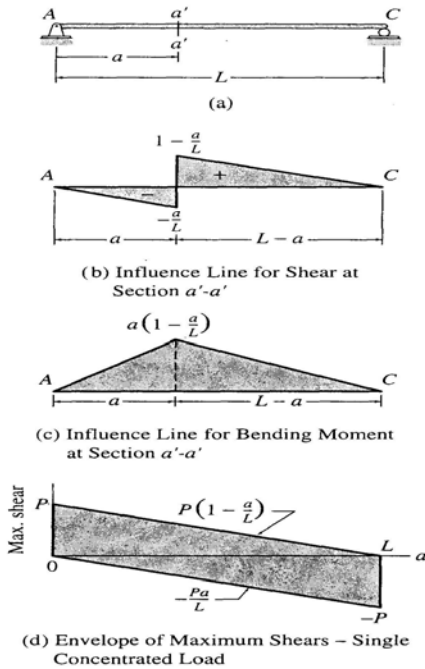

55

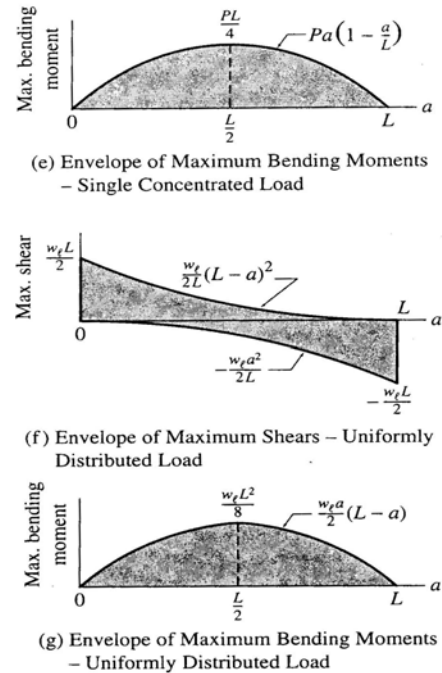

56