

SECTION 4 - FOUNDATIONS

Part A General Requirements and Materials

4.1 GENERAL

Foundations shall be designed to support all live and dead loads, and earth and water pressure loadings in accordance with the general principles specified in this section. The design shall be made either with reference to service loads and allowable stresses as provided in SERVICE LOAD DESIGN or, alternatively, with reference to load factors, and factored strength as provided in STRENGTH DESIGN.

4.2 FOUNDATION TYPE AND CAPACITY

4.2.1 Selection of Foundation Type

Selection of foundation type shall be based on an assessment of the magnitude and direction of loading, depth to suitable bearing materials, evidence of previous flooding, potential for liquefaction, undermining or scour, swelling potential, frost depth and ease and cost of construction.

4.2.2 Foundation Capacity

Foundations shall be designed to provide adequate structural capacity, adequate foundation bearing capacity with acceptable settlements, and acceptable overall stability of slopes adjacent to the foundations. The tolerable level of structural deformation is controlled by the type and span of the superstructure.

4.2.2.1 Bearing Capacity

The bearing capacity of foundations may be estimated using procedures described in Articles 4.4, 4.5, or 4.6 for service load design and Articles 4.11, 4.12, or 4.13 for strength design, or other generally accepted theories. Such theories are based on soil and rock parameters

measured by in situ and/or laboratory tests. The bearing capacity may also be determined using load tests.

4.2.2.2 Settlement

The settlement of foundations may be determined using procedures described in Articles 4.4, 4.5, or 4.6 for service load design and Articles 4.11, 4.12, or 4.13 for strength design, or other generally accepted methodologies. Such methods are based on soil and rock parameters measured directly or inferred from the results of in situ and/or laboratory tests.

4.2.2.3 Overall Stability

The overall stability of slopes in the vicinity of foundations shall be considered as part of the design of foundations.

4.2.3 Soil, Rock, and Other Problem Conditions

Geologic and environmental conditions can influence the performance of foundations and may require special consideration during design. To the extent possible, the presence and influence of such conditions shall be evaluated as part of the subsurface exploration program. A representative, but not exclusive, listing of problem conditions requiring special consideration is presented in Table 4.2.3A for general guidance.

4.3 SUBSURFACE EXPLORATION AND TESTING PROGRAMS

The elements of the subsurface exploration and testing programs shall be the responsibility of the designer based on the specific requirements of the project and his or her experience with local geologic conditions.

TABLE 4.2.3A Problem Conditions Requiring Special Consideration

Problem Type	Description	Comments
Soil	Organic soil; highly plastic clay	Low strength and high compressibility
	Sensitive clay	Potentially large strength loss upon large straining
	Micaceous soil	Potentially high compressibility (often saprolitic)
	Expansive clay/silt; expansive slag	Potentially large expansion upon wetting
	Liquefiable soil	Complete strength loss and high deformations due to earthquake loading
Rock	Collapsible soil	Potentially large deformations upon wetting (Caliche; Loess)
	Pyritic soil	Potentially large expansion upon oxidation
	Laminated rock	Low strength when loaded parallel to bedding
	Expansive shale	Potentially large expansion upon wetting; degrades readily upon exposure to air/water
	Pyritic shale	Expands upon exposure to air/water
Condition	Soluble rock	Soluble in flowing and standing water (Limestone, Limerock, Gypsum)
	Cretaceous shale	Indicator of potentially corrosive ground water
	Weak claystone (Red Beds)	Low strength and readily degradable upon exposure to air/water
	Gneissic and Schistose Rock	Highly distorted with irregular weathering profiles and steep discontinuities
	Subsidence	Typical in areas of underground mining or high ground water extraction
Condition	Sinkholes/solutioning	Karst topography; typical of areas underlain by carbonate rock strata
	Negative skin friction/expansion loading	Additional compressive/uplift load on deep foundations due to settlement/uplift of soil
	Corrosive environments	Acid mine drainage; degradation of certain soil/rock types
	Permafrost/frost	Typical in northern climates
Condition	Capillary water	Rise of water level in silts and fine sands leading to strength loss

4.3.1 General Requirements

As a minimum, the subsurface exploration and testing programs shall define the following, where applicable:

- Soil strata
 - Depth, thickness, and variability
 - Identification and classification
 - Relevant engineering properties (i.e., shear strength, compressibility, stiffness, permeability, expansion or collapse potential, and frost susceptibility)

- Rock strata
 - Depth to rock
 - Identification and classification
 - Quality (i.e., soundness, hardness, jointing and presence of joint filling, resistance to weathering, if exposed, and solutioning)
 - Compressive strength (e.g., uniaxial compression, point load index)
 - Expansion potential
- Ground water elevation
- Ground surface elevation
- Local conditions requiring special consideration



Exploration logs shall include soil and rock strata descriptions, penetration resistance for soils (e.g., SPT or q_c), and sample recovery and RQD for rock strata. The drilling equipment and method, use of drilling mud, type of SPT hammer (i.e. safety, donut, hydraulic) or cone penetrometer (i.e., mechanical or electrical), and any unusual subsurface conditions such as artesian pressures, boulders or other obstructions, or voids shall also be noted on the exploration logs.

4.3.2 Minimum Depth

Where substructure units will be supported on spread footings, the minimum depth of the subsurface exploration shall extend below the anticipated bearing level a minimum of two footing widths for isolated, individual footings where $L \leq 2B$, and four footing widths for footings where $L > 5B$. For intermediate footing lengths, the minimum depth of exploration may be estimated by linear interpolation as a function of L between depths of $2B$ and $5B$ below the bearing level. Greater depths may be required where warranted by local conditions.

Where substructure units will be supported on deep foundations, the depth of the subsurface exploration shall extend a minimum of 20 feet below the anticipated pile or shaft tip elevation. Where pile or shaft groups will be used, the subsurface exploration shall penetrate sufficient depth into firm stable material to insure that significant settlement will not develop from compression of the deeper soils due to loads imposed by the structure. For piles or shafts bearing on rock, a minimum of 10 feet of

rock core, or a length of rock core equal to three times the pile or shaft diameter below anticipated tip elevation, whichever is greater, shall be obtained to insure the exploration has not been terminated on a boulder. For shaft group bearing on rock the exploration shall penetrate sufficient depth into competent rock to determine the physical characteristics of rock within the zone of foundation influence for design.

4.3.3 Minimum Coverage

Unless the subsurface conditions of the site are known to be uniform, a minimum of one soil boring shall be made for each substructure unit. For substructure units over 100' in width, a minimum of two borings shall be required.

4.3.4 Laboratory Testing

Laboratory testing shall be performed as necessary to determine engineering properties including unit weight, shear strength, compressive strength and compressibility. In the absence of laboratory testing, engineering properties may be estimated based on published test results or local experience.

4.3.5 Scour

The probable depth of scour shall be determined by subsurface exploration and hydraulic studies. Refer to Article 1.3.2 and FHWA (1988) for general guidance regarding hydraulic studies and design.

Part B
Service Load Design Method
Allowable Stress Design

4.4 SPREAD FOOTINGS

4.4.1 General

4.4.1.1 Applicability

Provisions of this Article shall apply for design of isolated footings, and to combined footings and mats (footings supporting more than one column, pier, or wall).

4.4.1.2 Footings Supporting Non-Rectangular Columns or Piers

Footings supporting circular or regular polygon-shaped concrete columns or piers may be designed assuming that the columns or piers act as square members with the same area for location of critical sections for moment, shear, and development of reinforcement.

4.4.1.3 Footings in Fill

+ Footings located in fill are subject to the same bearing capacity and settlement considerations as footings in natural soil in accordance with Articles 4.4.7.1 through 4.4.7.2. The behavior of both the fill and underlying natural soil shall be considered.

4.4.1.4 Footings in Sloped Portions of Embankments

The earth pressure against the back of footings and columns within the sloped portion of an embankment shall be equal to the at-rest earth pressure in accordance with Article 5.5.2. The resistance due to the passive earth pressure of the embankment in front of the footing shall be neglected to a depth equal to a minimum depth of 3 feet, the depth of anticipated scour, freeze thaw action, and/or trench excavation in front of the footing, whichever is greater.

4.4.1.5 Distribution of Bearing Pressure

Footings shall be designed to keep the maximum soil and rock pressures within safe bearing values. To prevent unequal settlement, footings shall be designed to keep the

bearing pressure as nearly uniform as practical. For footings supported on piles or drilled shafts, the spacing between piles and drilled shafts shall be designed to ensure nearly equal loads on deep foundation elements as may be practical.

When footings support more than one column, pier, or wall, distribution of soil pressure shall be consistent with properties of the foundation materials and the structure, and with the principles of geotechnical engineering.

4.4.2 Notations

The following notations shall apply for the design of spread footings on soil and rock:

A	=	Contact area of footing (ft ²)
A'	=	Effective footing area for computation of bearing capacity of a footing subjected to eccentric load (ft ²); (See Article 4.4.7.1.1.1)
b _c , b _γ , b _q	=	Base inclination factors (dim); (See Article 4.4.7.1.1.8)
B	=	Width of footing (ft); (Minimum plan dimension of footing unless otherwise noted)
B'	=	Effective width for load eccentric in direction of short side, L unchanged (ft)
c	=	Soil cohesion (ksf)
c'	=	Effective stress soil cohesion (ksf)
c*	=	Reduced effective stress soil cohesion for punching shear (ksf); (See Article 4.4.7.1)
c _a	=	Adhesion between footing and foundation soil or rock (ksf); (See Article 4.4.7.1.1.3)
c _v	=	Coefficient of consolidation (ft ² /yr); (See Article 4.4.7.2.3)
c ₁	=	Shear strength of upper cohesive soil layer below footing (ksf); (See Article 4.4.7.1.1.7)
c ₂	=	Shear strength of lower cohesive soil layer below footing (ksf); (See Article 4.4.7.1.1.7)
C _c	=	Compression index (dim); (See Article 4.4.7.2.3)
C _{cr}	=	Recompression index (dim); (See Article 4.4.7.2.3)
C _{ce}	=	Compression ratio (dim); (See Article 4.4.7.2.3)
C _o	=	Uniaxial compressive strength of intact rock (ksf)
C _{re}	=	Recompression ration (dim); (See Article 4.4.7.2.3)
C _{oe}	=	Coefficient of secondary compression defined as change in height per log cycle of time (dim); (See Article 4.4.7.2.4)

D	= Influence depth for water below footing (ft); (See Article 4.4.7.1.1.6)	L_1	= Length (or width) of footing having positive contact pressure (compression) for footing loaded eccentrically about one axis (ft)
D_f	= Depth to base of footing (ft)	n	= Exponential factor relating B/L or L/B ratios for inclined loading (dim); (See Article 4.4.7.1.1.3)
e	= Void ratio (dim); (See Article 4.4.7.2.3)	N	= Standard penetration resistance (blows/ft)
e_f	= Void ratio at final vertical effective stress (dim); (See Article 4.4.7.2.3)	N_1	= Standard penetration resistance corrected for effects of overburden pressure (blows/ft); (See Article 4.4.7.2.2)
e_o	= Void ratio at initial vertical effective stress (dim); (See Article 4.4.7.2.3)	N_c, N_γ, N_q	= Bearing capacity factors based on the value of internal friction of the foundation soil (dim); (See Article 4.4.7.1)
e_p	= Void ratio at maximum past vertical effective stress (dim); (See Article 4.4.7.2.3)	N_m	= Modified bearing capacity factor to account for layered cohesive soils below footing (dim); (See Article 4.4.7.1.1.7)
e_B	= Eccentricity of load in the B direction measured from centroid of footing (ft) (See Article 4.4.7.1.1.1)	N_{ms}	= Coefficient factor to estimate q_{ult} for rock (dim); (See Article 4.4.8.1.2)
e_L	= Eccentricity of load in the L direction measured from centroid of footing (ft); (See Article 4.4.7.1.1.1)	N_s	= Stability number (dim); (See Article 4.4.7.1.1.4)
E_o	= Modulus of intact rock (ksf)	$N_{cq}, N_{\gamma q}$	= Modified bearing capacity factors for effects of footing on or adjacent sloping ground (dim); (See Article 4.4.7.1.1.4)
E_m	= Rock mass modulus (ksf) (See Article 4.4.8.2.2.)	P	= Tangential component of force on footing (k)
E_s	= Soil modulus (ksf)	P_{max}	= Maximum resisting force between footing base and foundation soil or rock for sliding failure (k)
F	= Total force on footing subjected to an inclined load (k); (See Article 4.4.7.1.1.1)	q	= Effective overburden pressure at base of footing (ksf)
f'_c	= Unconfined compressive strength of concrete (ksf)	Q	= Normal component of force on footing (k)
FS	= Factor of safety against bearing capacity, overturning or sliding shear failure (dim)	q_{all}	= Allowable uniform bearing capacity (ksf)
H	= Depth from footing base to top of second cohesive soil layer for two-layer cohesive soil profile below footing (ft); (See Article 4.4.7.1.1.7)	q_c	= Cone penetration resistance (ksf)
H_c	= Height of compressible soil layer (ft)	q_{max}	= Maximum footing contact pressure (ksf)
H_{crit}	= Critical thickness of the upper layer of a two-layer system beyond which the underlying layer will have little effect on the bearing capacity of footings bearing in the upper layer (ft) (See Article 4.4.7.1.1.7)	Q_{max}	= Maximum normal component of load supported by foundation soil or rock at ultimate bearing capacity (k)
H_d	= Height of longest drainage path in compressible soil layer (ft)	q_{min}	= Minimum magnitude of footing contact pressure (ksf)
H_s	= Height of slope (ft); (See Article 4.4.7.1.1.4)	q_n	= Nominal bearing resistance (ksf) (see Article 4.4.7)
i	= Slope angle from horizontal of ground surface below footing (deg)	q_o	= Unfactored vertical pressure at base of loaded area (ksf); (See Article 4.4.7.2.1)
i_c, i_γ, i_q	= Load inclination factors (dim); (See Article 4.4.7.1.1.3)	q_{os}	= Unfactored bearing pressure (ksf) causing the maximum allowable elastic settlement (see Article 4.4.7.2.2)
I_p	= Influence coefficient to account for rigidity and dimensions of footing (dim); (See Article 4.4.8.2.2)	q_{ult}	= Ultimate bearing capacity for uniform bearing pressure (ksf)
l	= Center-to-center spacing between adjacent footings (ft)	q_1	= Ultimate bearing capacity of footing supported in the upper layer of a two-layer system assuming the upper layer is infi-
L	= Length of footing (ft)		
L'	= Effective footing length for load eccentric in direction of long side, B unchanged (ft)		

q_2	=	ninitely thick (ksf) (See Article 4.4.7.1.1.7) = Ultimate bearing capacity of a fictitious footing of the same size and shape as the actual footing, but supported on surface of the second (lower) layer of a two-layer system (ksf); (See Article 4.4.7.1.1.7)	θ	=	Angle of load eccentricity (deg)
R	=	Resultant of pressure on base of footing (k)	κ	=	Shear strength ratio (c_2/c_1) for two layered cohesive soil system below footing (dim); (See Article 4.4.7.1.1.7)
r	=	Radius of circular footing or B/2 for square footing (ft); (See Article 4.4.8.2.2)	μ_c	=	Reduction factor to account for three-dimensional effects in settlement analysis (dim); (See Article 4.4.7.2.3)
RQD	=	Rock Quality Designation (dim)	ν	=	Poisson's ratio (dim)
S_c, S_γ, S_q	=	Footing shape factors (dim); (See Article 4.4.7.1.1.2)	σ'_f	=	Final vertical effective stress in soil at depth interval below footing (ksf); (See Article 4.4.7.2.3)
S_u	=	Undrained shear strength of soil (ksf)	σ'_o	=	Initial vertical effective stress in soil at depth interval below footing (ksf); (See Article 4.4.7.2.3)
S_c	=	Consolidation settlement (ft); (See Article 4.4.7.2.3)	σ'_p	=	Maximum past vertical effective stress in soil at depth interval below footing (ksf); (See Article 4.4.7.2.3)
S_e	=	Elastic or immediate settlement (ft); (See Article 4.4.7.2.2)	ϕ	=	Angle of internal friction (deg)
S_s	=	Secondary settlement (ft); (See Article 4.4.7.2.4)	ϕ'	=	Effective stress angle of internal friction (deg)
S_t	=	Total settlement (ft); (See Article 4.4.7.2)	ϕ^*	=	Reduced effective stress soil friction angle for punching shear (ksf); (See Article 4.4.7.1)
t	=	Time to reach specified average degree of consolidation (yr); (See Article 4.4.7.2.3)			
t_1, t_2	=	Arbitrary time intervals for determination of S_s (yr); (See Article 4.4.7.2.4)			
T	=	Time factor (dim); (See Article 4.4.7.2.3)			
Z_w	=	Depth from footing base down to the highest anticipated ground water level (ft); (See Article 4.4.7.1.1.6)			
α	=	Angle of inclination of the footing base from the horizontal (radian)			
α_e	=	Reduction factor (dim); (See Article 4.4.8.2.2)			
β	=	Length to width ratio of footing (dim)			
β_m	=	Punching index = $BL/[2(B+L)H]$ (dim); (See Article 4.4.7.1.1.7)			
β_z	=	Factor to account for footing shape and rigidity (dim); (See Article 4.4.7.2.2)			
γ	=	Total unit weight of soil or rock (kcf)			
γ'	=	Buoyant unit weight of soil or rock (kcf)			
γ_m	=	Moist unit weight of soil (kcf)			
δ	=	Angle of friction between footing and foundation soil or rock (deg); (See Article 4.4.7.1.1.3)			
ϵ_v	=	Vertical strain (dim); (See Article 4.4.7.2.3)			
ϵ_{vf}	=	Vertical strain at final vertical effective stress (dim); (See Article 4.4.7.2.3)			
ϵ_{vo}	=	Initial vertical strain (dim); (See Article 4.4.7.2.3)			
ϵ_{vp}	=	Vertical strain at maximum past vertical effective stress (dim); (See Article 4.4.7.2.3)			

The notations for dimension units include the following: dim = Dimensionless; deg = degree; ft = foot; k = kip; k/ft = kip/ft; ksf = kip/ft²; kcf = kip/ft³; lb = pound; in. = inch; and psi = pound per square inch. The dimensional units provided with each notation are presented for illustration only to demonstrate a dimensionally correct combination of units for the footing capacity procedures presented herein. If other units are used, the dimensional correctness of the equations shall be confirmed.

4.4.3 Design Terminology

Refer to Figure 4.4.3A for terminology used in the design of spread footing foundations.

4.4.4 Soil and Rock Property Selection

Soil and rock properties defining the strength and compressibility characteristics of the foundation materials are required for footing design. Foundation stability and settlement analyses for design shall be conducted using soil and rock properties based on the results of field and/or laboratory testing.

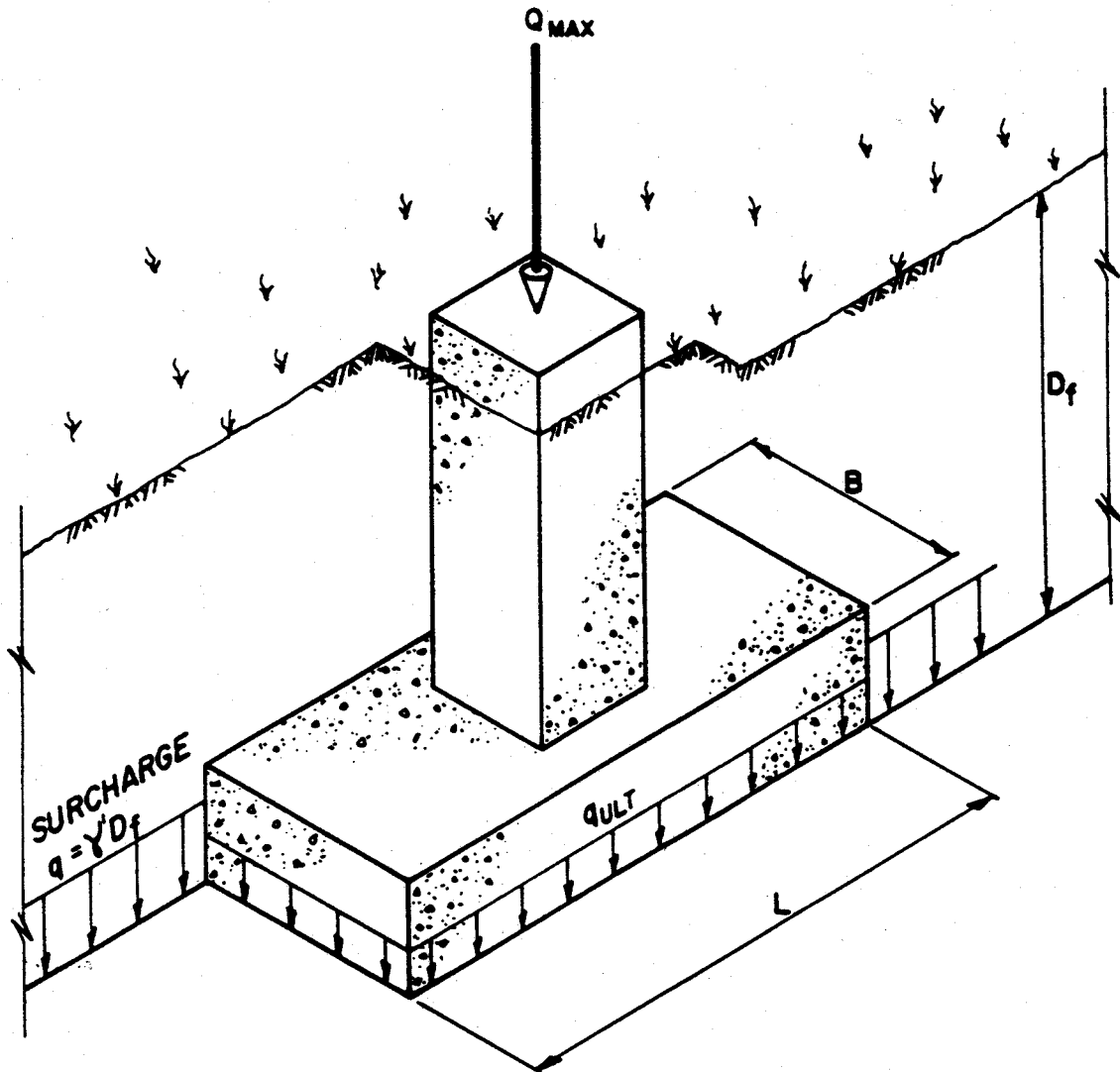

FIGURE 4.4.3A Design Terminology for Spread Footing Foundations

4.4.5 Depth

4.4.5.1 Minimum Embedment and Bench Width

Footings not otherwise founded on sound, non-degradable rock surfaces shall be embedded a sufficient depth to provide adequate bearing, scour and frost heave protection, or 3 feet to the bottom of footing, whichever is greatest. For footings constructed on slopes, a minimum horizontal distance of 4 feet, measured at the top of footing, shall be provided between the near face of the footing and the face of the finished slope.

4.4.5.2 Scour Protection

Footings supported on soil or degradable rock strata shall be embedded below the maximum computed scour depth or protected with a scour countermeasure. Footings supported on massive, competent rock formations which are highly resistant to scour shall be placed directly on the cleaned rock surface. Where required, additional lateral resistance should be provided by drilling and grouting steel dowels into the rock surface rather than blasting to embed the footing below the rock surface.

Footings on piles may be located above the lowest anticipated scour level provided the piles are designed for this condition. Assume that all of the degradation +
 + scour has occurred and none of the maximum anticipated
 + local scour (local pier and local contraction) has occurred
 + when designing for earthquake loading. Where footings
 on piles are subject to damage by boulders or debris
 during flood scour, adequate protection shall be pro-
 vided. Footings shall be constructed so as to neither pose
 an obstacle to water traffic nor be exposed to view during
 low flow.

+ Abutment footings shall be constructed so as to be
 + stable if scour or meandering causes loss of approach fill.

4.4.5.3 Footing Excavations

Footing excavations below the ground water table, particularly in granular soils having relatively high permeability, shall be made such that the hydraulic gradient in the excavation bottom is not increased to a magnitude that would cause the foundation soils to loosen or soften due to the upward flow of water. Further, footing excavations shall be made such that hydraulic gradients and material removal do not adversely affect adjacent structures. Seepage forces and gradients may be evaluated by flow net procedures or other appropriate methods. Dewatering or cutoff methods to control seepage shall be used where necessary.

Footing excavations in nonresistant, easily weathered moisture sensitive rocks shall be protected from weathering immediately after excavation with a lean mix concrete or other approved materials.

4.4.5.4 Piping

Piping failures of fine materials through rip-rap or through drainage backfills behind abutments shall be prevented by properly designed, graded soil filters or geotextile drainage systems.

4.4.6 Anchorage

Footings founded on inclined, smooth rock surfaces and which are not restrained by an overburden of resistant material shall be effectively anchored by means of rock anchors, rock bolts, dowels, keys, benching or other suitable means. Shallow keying or benching of large footing areas shall be avoided where blasting is required for rock removal.

4.4.7 Geotechnical Design on Soil

Spread footings on soil shall be designed to support the design loads with adequate bearing and structural capacity, and with tolerable settlements in conformance with Articles 4.4.7 and 4.4.11.

The location of the resultant of pressure (R) on the base of the footings shall be maintained within B/6 of the center of the footing.

The nominal bearing resistance, q_n , shall be taken as the lesser of the values q_{ult} and $3.0 q_{os}$.

4.4.7.1 Bearing Capacity

The ultimate bearing capacity (for general shear failure) may be estimated using the following relationship for continuous footings (i.e., $L > 5B$):

$$q_{ult} = cN_c + 0.5\gamma BN_\gamma + qN_q \quad (4.4.7.1-1)$$

The allowable bearing capacity shall be determined as:

$$q_{all} = q_n / FS \quad (4.4.7.1-2)$$

Refer to Table 4.4.7.1A for values of N_c , N_γ and N_q .

If local or punching shear failure is possible, the value of q_{ult} may be estimated using reduced shear strength parameters c^* and ϕ^* in 4.4.7.1-1 as follows:

$$c^* = 0.67c \quad (4.4.7.1-3)$$

$$\phi^* = \tan^{-1}(0.67 \tan \phi) \quad (4.4.7.1-4)$$

Effective stress methods of analysis and drained shear strength parameters shall be used to determine bearing capacity factors for drained loading conditions in all soils. Additionally, the bearing capacity of cohesive soils shall be checked for undrained loading conditions using bearing capacity factors based on undrained shear strength parameters.

4.4.7.1.1 Factors Affecting Bearing Capacity

A modified form of the general bearing capacity equation may be used to account for the effects of footing shape, ground surface slope, base inclination, and inclined loading as follows:

TABLE 4.4.7.1A Bearing Capacity Factors

ϕ	N_c	N_q	N_γ	ϕ	N_c	N_q	N_γ
0	5.14	1.00	0.00	26	22.25	11.85	12.54
1	5.38	1.09	0.07	27	23.94	13.20	14.47
2	5.63	1.20	0.15	28	25.80	14.72	16.72
3	5.90	1.31	0.24	29	27.86	16.44	19.34
4	6.19	1.43	0.34	30	30.14	18.40	22.40
5	6.49	1.57	0.45	31	32.67	20.63	25.99
6	6.81	1.72	0.57	32	35.49	23.18	30.22
7	7.16	1.88	0.71	33	38.64	26.09	35.19
8	7.53	2.06	0.86	34	42.16	29.44	41.06
9	7.92	2.25	1.03	35	46.12	33.30	48.03
10	8.35	2.47	1.22	36	50.59	37.75	56.31
11	8.80	2.71	1.44	37	55.63	42.92	66.19
12	9.28	2.97	1.69	38	61.35	48.93	78.03
13	9.81	3.26	1.97	39	67.87	55.96	92.25
14	10.37	3.59	2.29	40	75.31	64.20	109.41
15	10.98	3.94	2.65	41	83.86	73.90	130.22
16	11.63	4.34	3.06	42	93.71	85.38	155.55
17	12.34	4.77	3.53	43	105.11	99.02	186.54
18	13.10	5.26	4.07	44	118.37	115.31	224.64
19	13.93	5.80	4.68	45	133.88	134.88	271.76
20	14.83	6.40	5.39	46	152.10	158.51	330.35
21	15.82	7.07	6.20	47	173.64	187.21	403.67
22	16.88	7.82	7.13	48	199.26	222.31	496.01
23	18.05	8.66	8.20	49	229.93	265.51	613.16
24	19.32	9.60	9.44	50	266.89	319.07	762.89
25	20.72	10.66	10.88	—	—	—	—

$$q_{ult} = cN_c s_c b_c i_c + 0.5 \gamma B N_\gamma = \gamma s_\gamma b_\gamma i_\gamma + q N_q s_q b_q i_q \quad (4.4.7.1.1-1)$$

Reduced footing dimensions shall be used to account for the effects of eccentric loading.

4.4.7.1.1.1 Eccentric Loading

For loads eccentric relative to the centroid of the footing, reduced footing dimensions (B' and L') shall be used to determine bearing capacity factors and modifiers (i.e., slope, footing shape, and load inclination factors), and to calculate the ultimate load capacity of the footing. The reduced footing dimensions shall be determined as follows:

$$B' = B - 2e_B \quad (4.4.7.1.1.1-1)$$

$$L' = L - 2e_L \quad (4.4.7.1.1.1-2)$$

The effective footing area shall be determined as follows:

$$A' = B'L' \quad (4.4.7.1.1.1-3)$$

Refer to Figure 4.4.7.1.1A for loading definitions and footing dimensions.

The value of q_{ult} obtained using the reduced footing dimensions represents an equivalent uniform bearing pressure and not the actual contact pressure distribution beneath the footing. This equivalent pressure may be multiplied by the reduced area to determine the ultimate load capacity of the footing from the standpoint of bearing capacity. The actual contact pressure distribution (i.e., trapezoidal for the conventional assumption of a

rigid footing and a positive pressure along each footing edge) shall be used for structural design of the footing.

The actual distribution of contact pressure for a rigid footing with eccentric loading about one axis is shown in Figure 4.4.7.1.1.1B. For an eccentricity (e_L) in the L direction, the actual maximum and minimum contact pressures may be determined as follows:

for $e_L < L/6$:

$$(4.4.7.1.1.1-4)$$

$$q_{\min} = Q[1 - (6e_L/L)]/BL \quad (4.4.7.1.1.1-5)$$

for $L/6 < e_L < L/2$:

$$q_{\max} = 2Q/(3B[L/2] - e_L) \quad (4.4.7.1.1.1-6)$$

$$q_{\min} = 0 \quad (4.4.7.1.1.1-7)$$

$$L_1 = 3[(L/2) - e_L] \quad (4.4.7.1.1.1-8)$$

For an eccentricity (e_B) in the B direction, the maximum and minimum contact pressures may be determined using Equations 4.4.7.1.1.1-4 through 4.4.7.1.1.1-8 by replacing terms labeled L by B, and terms labeled B by L.

Footings on soil shall be designed so that the eccentricity of loading is less than $1/6$ of the footing dimension in any direction.

4.4.7.1.1.2 Footing Shape

For footing shapes other than continuous footings (i.e., $L < 5B$) the following shape factors shall be applied to Equation 4.4.7.1.1-1:

$$s_c = 1 + (B/L)(N_q/N_c) \quad (4.4.7.1.1.2-1)$$

$$s_q = 1 + (B/L) \tan \phi \quad (4.4.7.1.1.2-2)$$

$$s_\gamma = 1 - 0.4(B/L) \quad (4.4.7.1.1.2-3)$$

For circular footings, B equals L. For cases in which the loading is eccentric, the terms L and B shall be replaced by L' and B' respectively, in the above equations.

4.4.7.1.1.3 Inclined Loading

For inclined loads, the following inclination factors shall be applied in Equation 4.4.7.1.1-1:

$$i_c = i_q - [(1 - i_q)/N_c \tan \phi] \quad (\text{for } \phi > 0) \quad (4.4.7.1.1.3-1)$$

$$i_c = 1 - (nP/BLcN_c) \quad (\text{for } \phi = 0) \quad (4.4.7.1.1.3-2)$$

$$i_q = [1 - P/(Q + BLc \cot \phi)]^n \quad (4.4.7.1.1.3-3)$$

$$i_\gamma = [1 - P/(Q + BLc \cot \phi)]^{(n+1)} \quad (4.4.7.1.1.3-4)$$

$$n = [(2 + L/B)/(1 + L/B)] \cos^2 \theta + [(2 + B/L)/(1 + B/L)] \sin^2 \theta \quad (4.4.7.1.1.3-5)$$

Refer to Figure 4.4.7.1.1.1A for loading definitions and footing dimensions. For cases in which the loading is eccentric, the terms L and B shall be replaced by L' and B' respectively, in the above equations.

Failure by sliding shall be considered by comparing the tangential component of force on the footing (P) to the maximum resisting force (P_{\max}) by the following:

$$P_{\max} = Q \tan \delta + BLc_a \quad (4.4.7.1.1.3-6)$$

$$FS = P_{\max}/P \geq 1.5 \quad (4.4.7.1.1.3-7)$$

In determining P_{\max} , the effect of passive resistance provided by footing embedment shall be ignored, and BL shall represent the actual footing area in compression as shown in Figure 4.4.7.1.1.1B or Figure 4.4.7.1.1.1C.

4.4.7.1.1.4 Ground Surface Slope

For footings located on slopes or within 3B of a slope crest, q_{ult} may be determined using the following revised version of Equation 4.4.7.1.1-1:

$$q_{\text{ult}} = cN_{cq}s_c b_c i_c + 0.5\gamma'BN_{\gamma q}s_\gamma b_\gamma i_\gamma \quad (4.4.7.1.1.4-1)$$

Refer to Figure 4.4.7.1.1.4A for values of N_{cq} and $N_{\gamma q}$ for footings on slopes and Figures 4.4.7.1.1.4B for values of N_{cq} and $N_{\gamma q}$ for footings at the top of slopes. For footings in or above cohesive soil slopes, the stability number in the figures, N_s is defined as follows:

$$N_s = \gamma H_s/c \quad (4.4.7.1.1.4-2)$$

Overall stability shall be evaluated for footings on or adjacent to sloping ground surfaces as described in Article 4.4.9.

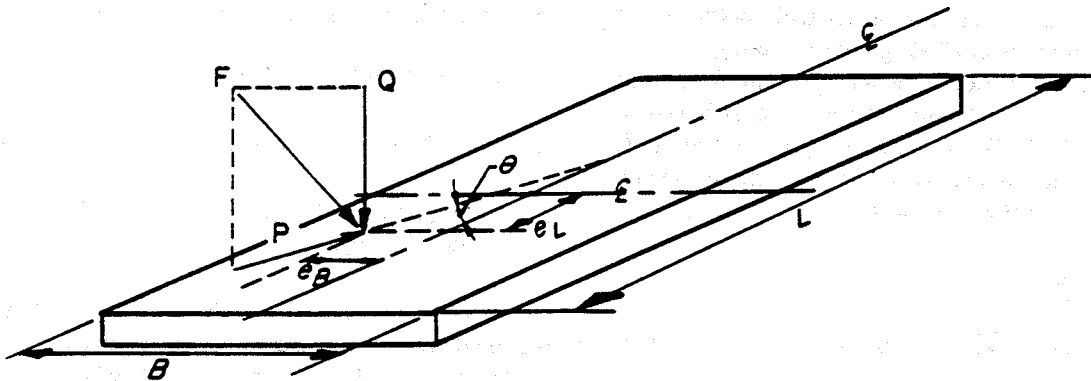

FIGURE 4.4.7.1.1.1A Definition Sketch for Loading and Dimensions for Footings Subjected to Eccentric or Inclined Loads Modified after EPRI (1983)

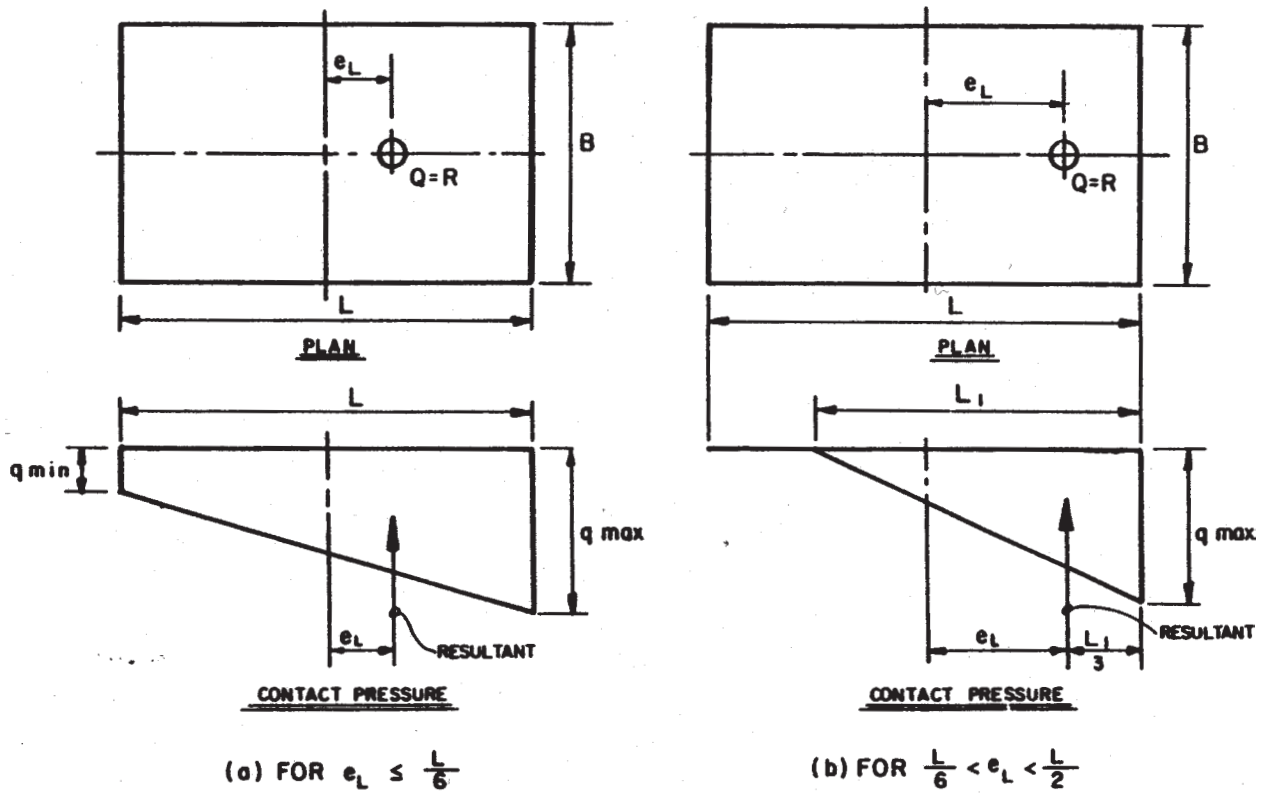

FIGURE 4.4.7.1.1.1B Contact Pressure for Footing Loaded Eccentrically About One Axis

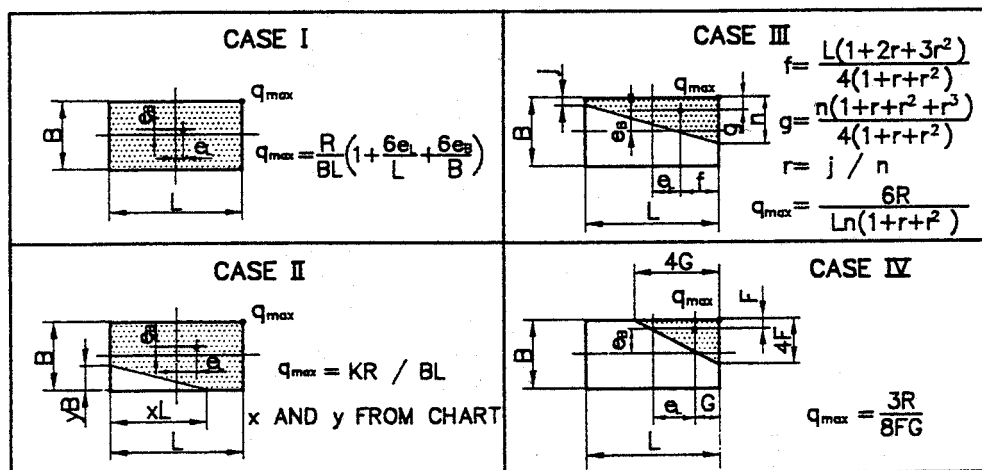
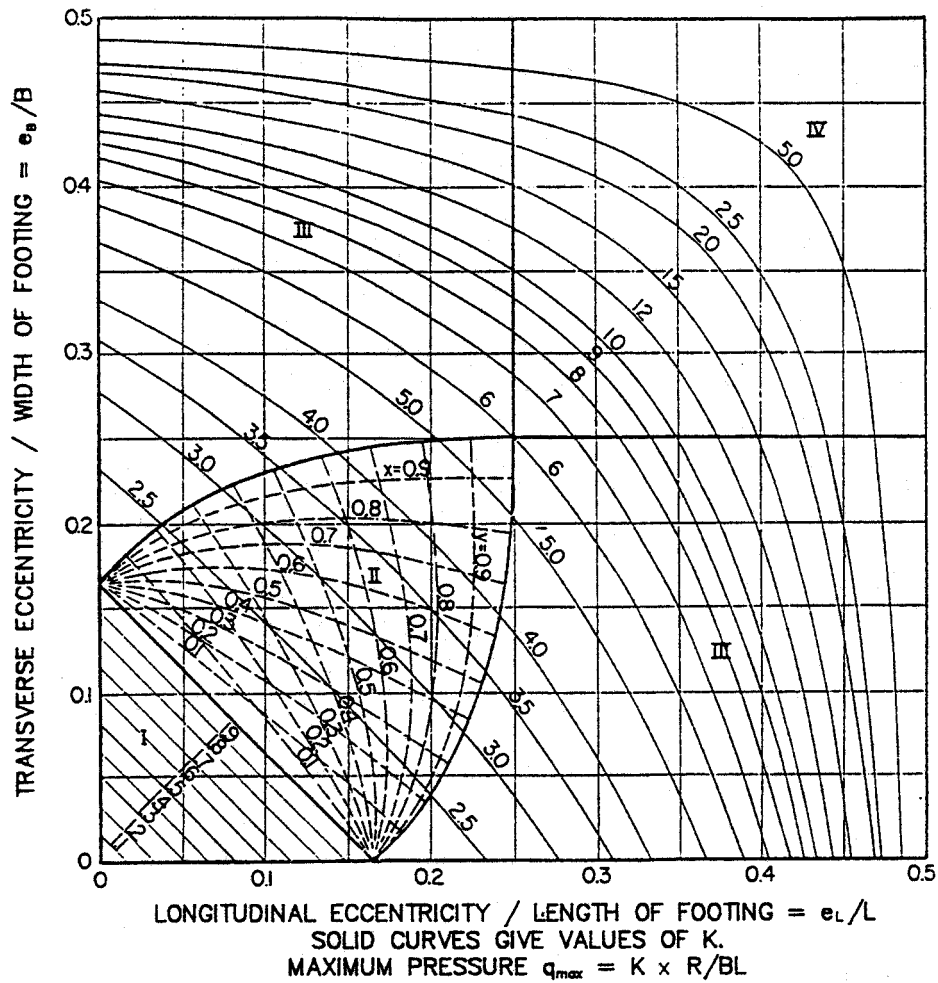

FIGURE 4.4.7.1.1.1C Contact Pressure for Footing Loaded Eccentrically About Two Axes Modified after AREA (1980)

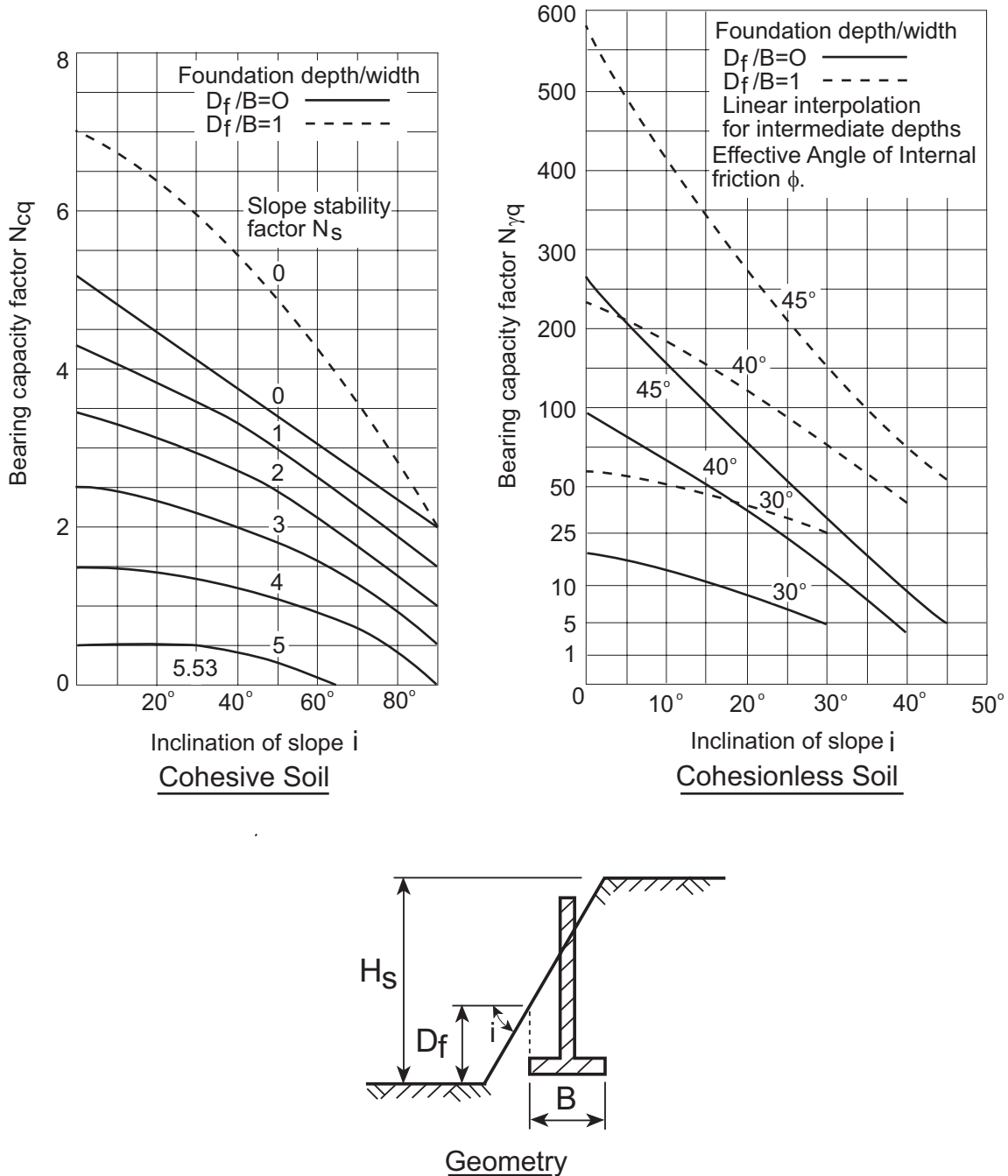

FIGURE 4.4.7.1.1.4A Modified Bearing Capacity Factors for Footing on Sloping Ground Modified after Meyerhof (1957)

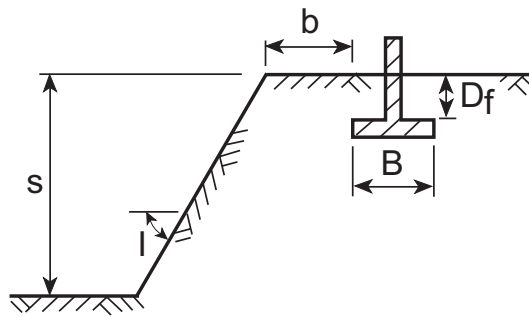
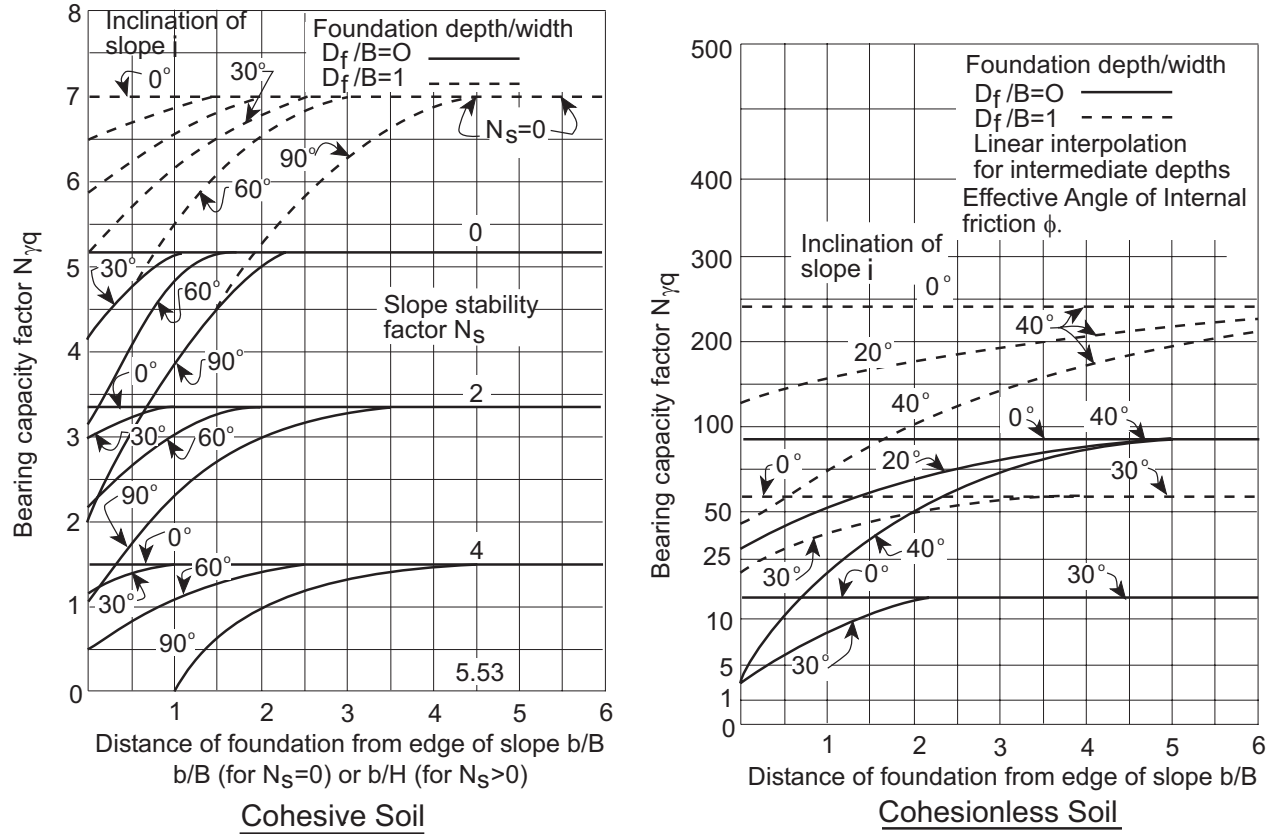

FIGURE 4.4.7.1.1.4B Modified Bearing Capacity Factors for Footing Adjacent Sloping Ground Modified after Meyerhof (1957)

4.4.7.1.1.5 Embedment Depth

The shear strength of soil above the base of footings is neglected in determining q_{ult} using Equation 4.4.7.1.1-1. If other procedures are used, the effect of embedment shall be consistent with the requirements of the procedure followed.

4.4.7.1.1.6 Ground Water

Ultimate bearing capacity shall be determined using the highest anticipated ground water level at the footing location. The effect of ground water level on the ultimate bearing capacity shall be considered by using a weighted average soil unit weight in Equation 4.4.7.1.1-1. If $\phi < 37^\circ$, the following equations may be used to determine the weighted average unit weight:

$$\text{for } z_w \geq B : \text{ use } \gamma = \gamma_m \text{ (no effect)} \quad (4.4.7.1.1.6-1)$$

$$\text{for } z_w < B : \text{ use } \gamma = \gamma' + (z_w/B)(\gamma_m - \gamma') \quad (4.4.7.1.1.6-2)$$

$$\text{for } z_w \leq 0 : \text{ use } \gamma = \gamma' \quad (4.4.7.1.1.6-3)$$

Refer to Figure 4.4.7.1.1.6A for definition of terms used in these equations. If $\phi > 37^\circ$, the following equations may be used to determine the weighted average unit weight:

$$\gamma = (2D - z_w)(z_w \gamma_m / D^2)(z_w \gamma_m / D^2) + \gamma' / D^2 (D - z_w)^2 \quad (4.4.7.1.1.6-4)$$

$$D = 0.5B \tan(45^\circ + \phi/2) \quad (4.4.7.1.1.6-5)$$

4.4.7.1.1.7 Layered Soils

If the soil profile is layered, the general bearing capacity equation shall be modified to account for differences

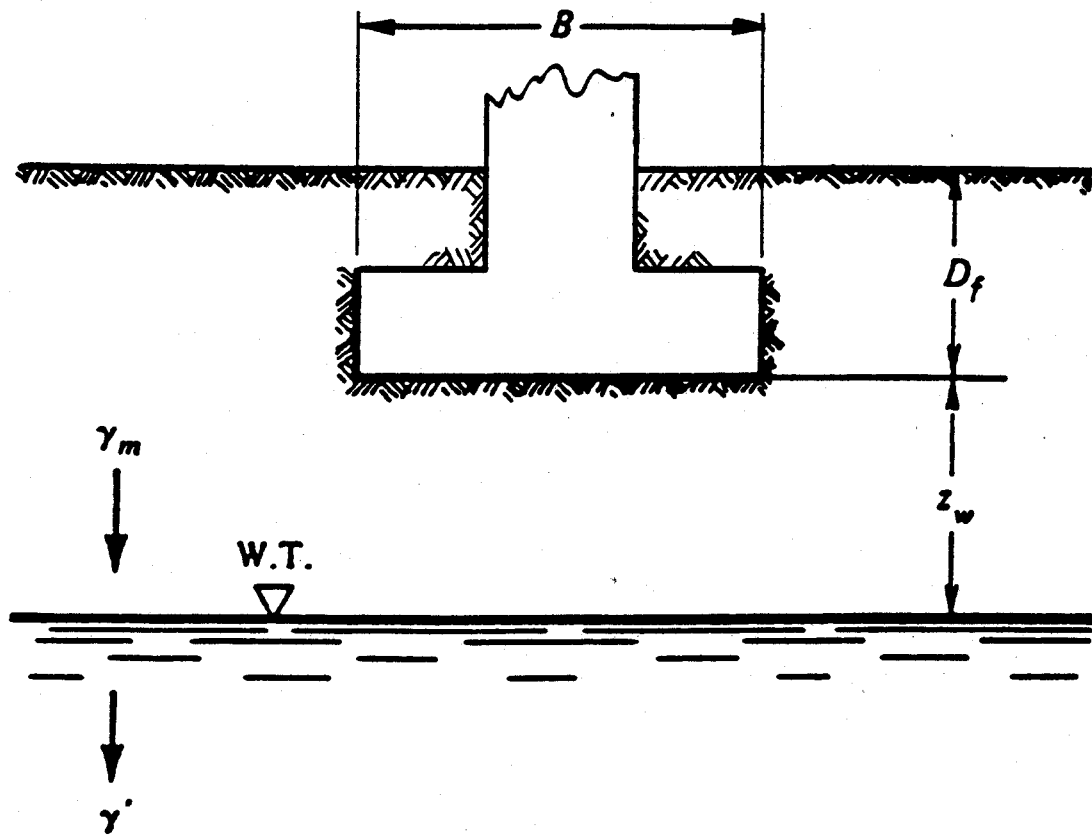

FIGURE 4.4.7.1.1.6A Definition Sketch for Influence of Ground Water Table on Bearing Capacity

in failure modes between the layered case and the homogeneous soil case assumed in Equation 4.4.7.1.1-1.

Undrained Loading

For undrained loading of a footing supported on the upper layer of a two-layer cohesive soil system, q_{ult} may be determined by the following:

$$q_{ult} = c_1 N_m + q \quad (4.4.7.1.1.7-1)$$

Refer to Figure 4.4.7.1.1.7A for the definition of c_1 . For undrained loading, c_1 equals the undrained soil shear strength s_{ul} , and $\phi_1=0$.

If the bearing stratum is a cohesive soil which overlies a stiffer cohesive soil, refer to Figure 4.4.7.1.1.7B to determine N_m . If the bearing stratum overlies a softer layer, punching shear should be assumed and N_m may be calculated by the following:

$$N_m = (1/b_m + k s_c N_c) \leq s_c N_c \quad (4.4.7.1.1.7-2)$$

Drained Loading

For drained loading of a footing supported on a strong layer overlying a weak layer in a two-layer system, q_{ult} may be determined using the following:

$$q_{ult} = [q_2 + (1/K)c_1' \cot \phi_1'] \exp + \{2[1 + (B/L)]K \tan \phi_1' (H/B)\} - (1/K)c_1' \cot \phi_1' \quad (4.4.7.1.1.7-3)$$

The subscripts 1 and 2 refer to the upper and lower layers, respectively. $K = (1 - \sin^2 \phi_1') / (1 + \sin^2 \phi_1')$ and q_2 equals q_{ult} of a fictitious footing of the same size and shape as the actual footing but supported on the second (or lower) layer. Reduced shear strength values shall be used to determine q_2 in accordance with Article 4.4.7. 1.

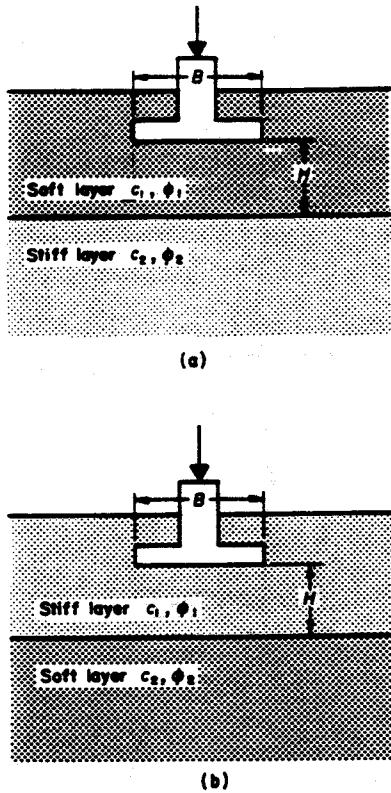

FIGURE 4.4.7.1.1.7A
Typical Two-Layer Soil Profiles

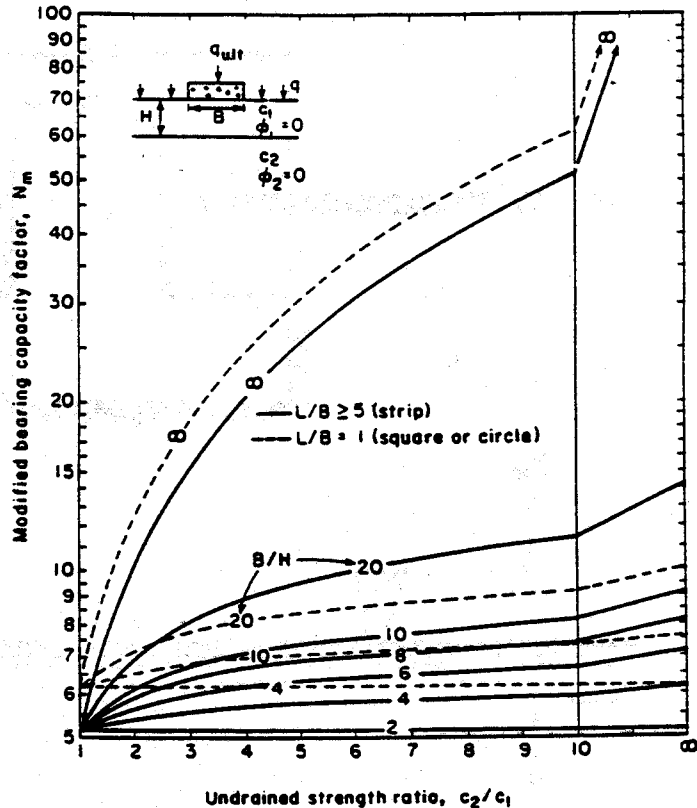

FIGURE 4.4.7.1.1.7B Modified Bearing Capacity
Factor for Two-Layer Cohesive Soil with Softer Soil
Overlying Stiffer Soil EPRI (1983)

If the upper layer is a cohesionless soil and ϕ' equals 25° to 50° , Equation 4.4.7.1.1.7-3 reduces to:

$$q_{ult} = q_2 \exp\{0.67[1 + (B/L)]H/B\} \quad (4.4.7.1.1.7-4)$$

The critical depth of the upper layer beyond which the bearing capacity will generally be unaffected by the presence of the lower layer is given by the following:

$$H_{crit} = [3B1n(q_1/q_2)]/[2(1 + B/L)] \quad (4.4.7.1.1.7-5)$$

In the equation, q_1 equals the bearing capacity of the upper layer assuming the upper layer is of infinite extent.

4.4.7.1.1.8 Inclined Base

Footings with inclined bases are generally not recommended. Where footings with inclined bases are necessary, the following factors shall be applied in Equation 4.4.7.1.1-1:

$$b_q = b_\gamma = (1 - \alpha \tan \phi)^2 \quad (4.4.7.1.1.8-1)$$

$$b_c = b_\gamma - (1 - b_\gamma)/(N_c \tan \phi) \quad (\text{for } \phi > 0) \quad (4.4.7.1.1.8-2)$$

$$b_c = 1 - [2\alpha/(\pi + 2)] \quad (\text{for } \phi = 0) \quad (4.4.7.1.1.8-3)$$

Refer to Figure 4.4.7.1.1.8A for definition sketch. Where footings must be placed on sloping surfaces, refer to Article 4.4.6 for anchorage requirements.

4.4.7.1.2 Factors of Safety

Spread footings on soil shall be designed for Group 1 loadings using a minimum factor of safety (FS) of 3.0 against a bearing capacity failure.

4.4.7.2 Settlement

The total settlement includes elastic, consolidation, and secondary components and may be determined using the following:

$$S_t = S_e + S_c + S_s \quad (4.4.7.2-1)$$

Elastic settlement shall be determined using the unfactored dead load, plus the unfactored component of live and impact loads assumed to extend to the footing level. Consolidation and secondary settlement may be determined using the full unfactored dead load only.

Other factors which can affect settlement (e.g., embankment loading, lateral and/or eccentric loading, and for footings on granular soils, vibration loading from dynamic live loads or earthquake loads) should also be considered, where appropriate. Refer to Gifford, et al.,

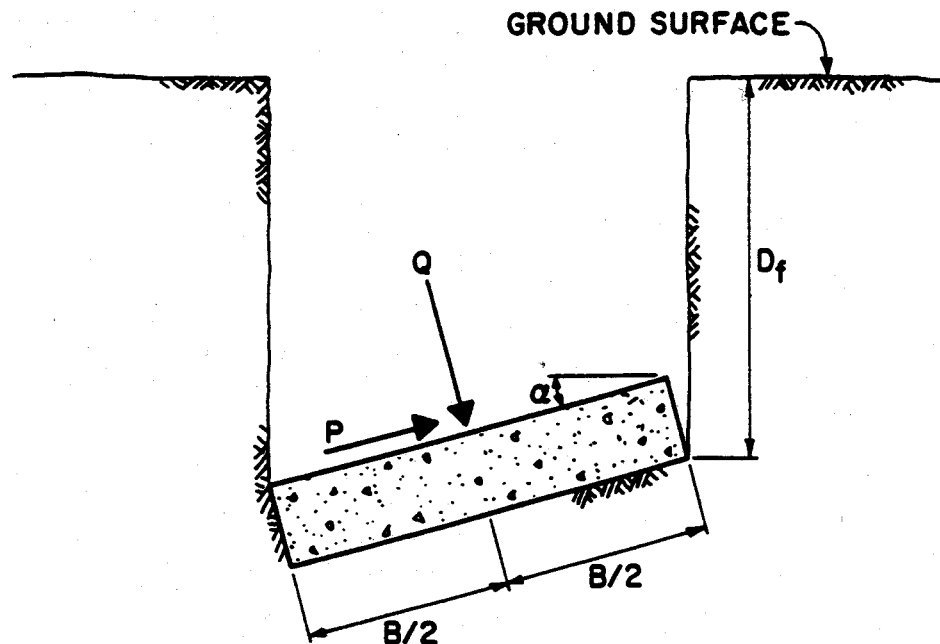

FIGURE 4.4.7.1.1.8A Definition Sketch for Footing Base Inclination

(1987) for general guidance regarding static loading conditions and Lam and Martin (1986) for guidance regarding dynamic/seismic loading conditions.

4.4.7.2.1 Stress Distribution

Figure 4.4.7.2.1A may be used to estimate the distribution of vertical stress increase below circular (or square) and long rectangular footings (i.e., where $L > 5B$). For other footing geometries, refer to Poulos and Davis (1974).

Some methods used for estimating settlement of footings on sand include an integral method to account for the effects of vertical stress increase variations. Refer to Gifford, et al., (1987) for guidance regarding application of these procedures.

4.4.7.2.2 Elastic Settlement

The elastic settlement of footings on cohesionless soils and stiff cohesive soils may be estimated using the following:

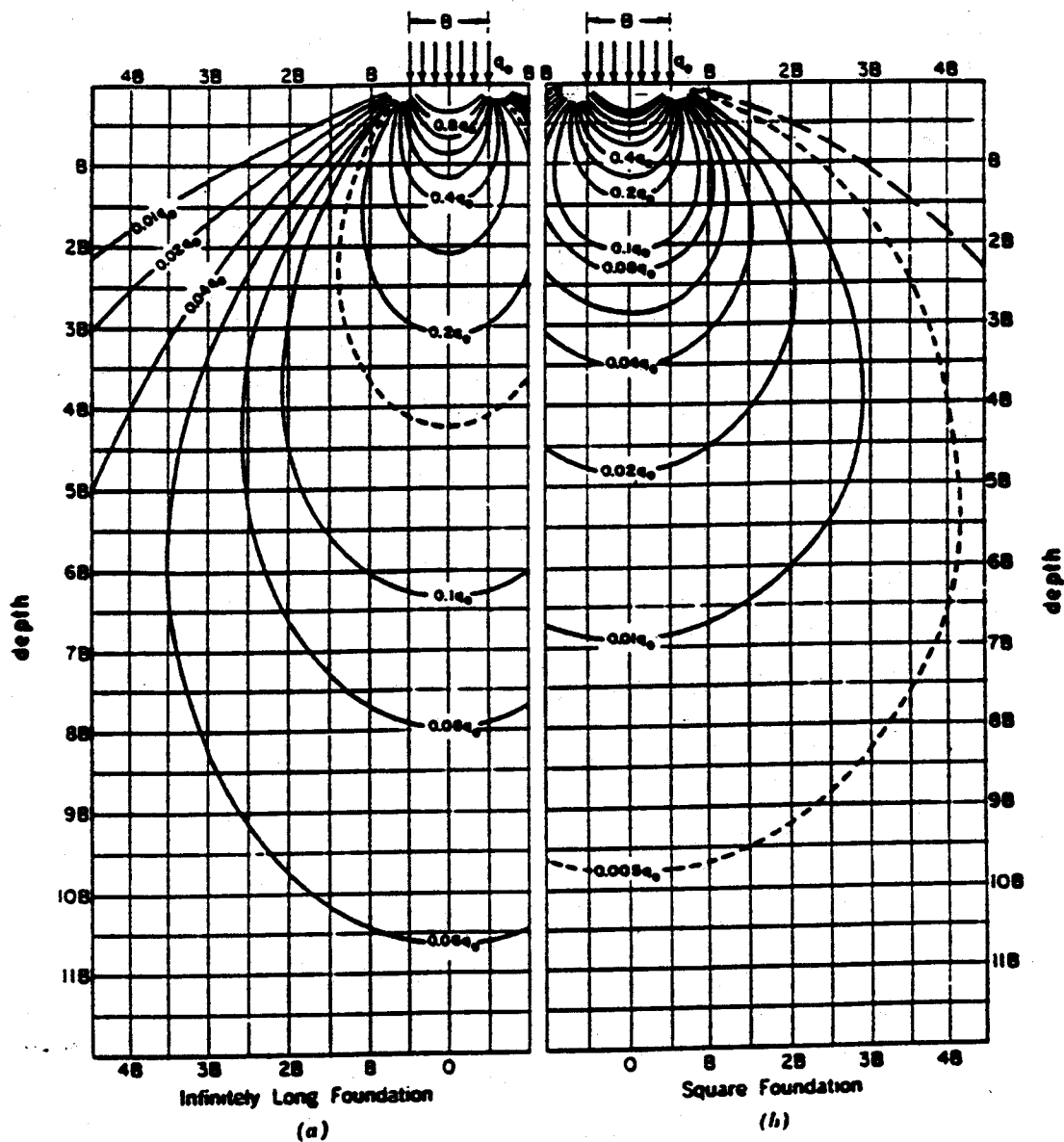

FIGURE 4.4.7.2.1A Boussinesq Vertical Stress Contours for Continuous and Square Footings Modified after Sowers (1979)

TABLE 4.4.7.2.2A Elastic Constants of Various Soils
Modified after U.S. Department of the Navy (1982) and Bowles (1982)

Typical Range of Values			Estimating E_s From E_s From $N^{(1)}$		
Soil Type	Young's Modulus, E_s (ksf)	Poisson's Ratio, ν (dim)	Soil Type	E_s (ksf)	
Clay:					
Soft sensitive	50-300	0.4-0.5	Silts, sandy silts, slightly cohesive mixtures	$8N_1^{(2)}$	
Medium stiff to stiff	300-1,000	(undrained)	Clean fine to medium sands and slightly silty sands	$14N_1$	
Very stiff	1,000-2,000		Coarse sands and sands with little gravel	$20N_1$	
			Sandy gravel and gravels	$24N_1$	
Loess	300-1,200	0.1-0.3			
Silt	40-400	0.3-0.35			
Fine sand:					
Loose	160-240	0.25	Estimating E_s From $s_u^{(3)}$		
Medium dense	240-400				
Dense	400-600				
Sand:					
Loose	200-600	0.2-0.35	Soft sensitive clay	$400s_u-1,000s_u$	
Medium dense	600-1,000	0.3-0.4	Medium stiff to stiff clay	$1,500s_u-2,400s_u$	
Dense	1,000-1,600		Very stiff clay	$3,000s_u-4,000s_u$	
Gravel:					
Loose	600-1,600	0.2-0.35	Estimating E_s From $q_c^{(4)}$		
Medium dense	1,600-2,000	0.3-0.4	Sandy soils	$4q_c$	
Dense	2,000-4,000				

⁽¹⁾ N = Standard Penetration Test (SPT) resistance.

⁽²⁾ N_1 = SPT corrected for depth.

⁽³⁾ s_u = Undrained shear strength (ksf).

⁽⁴⁾ q_c = Cone penetration resistance (ksf).

TABLE 4.4.7.2.2B Elastic Shape and Rigidity Factors EPRI (1983)

L/B	β_z Flexible (average)	β_z Rigid
Circular	1.04	1.13
1	1.06	1.08
2	1.09	1.10
3	1.13	1.15
5	1.22	1.24
10	1.41	1.41

$$S_e = \lfloor q_o (1 - \nu^2) \sqrt{A} \rfloor / E_s \beta_z \quad (4.4.7.2.2-1)$$

Refer to Table 4.4.7.2.2A for approximate values of E_s and ν for various soil types, and Table 4.4.7.2.2B for values of β_z for various shapes of flexible and rigid footings. Unless E_s varies significantly with depth, E_s should be determined at a depth of about $1/2$ to $2/3$ of B below the footing. If the soil modulus varies significantly with depth, a weighted average value of E_s may be used.

Refer to Gifford, et al., (1987) for general guidance regarding the estimation of elastic settlement of footings on sand.

For determining the nominal bearing resistance, q_{os} shall be the value of q_o which produces elastic settlements of

$S_e = 1$ inch in structures with continuous spans or multi-column bents

$S_e = 2$ inches in simple span structures.

4.4.7.2.3 Consolidation Settlement

The consolidation settlement of footings on saturated or nearly saturated cohesive soils may be estimated using the following when laboratory test results are expressed in terms of void ratio (e):

- For initial overconsolidated soils (i.e., $s_p' > s_o'$):

$$S_c = [H_c / (1 + e_o)] [(C_{cr} \log \{s_p' / s_o'\} + C_c \log \{s_f' / s_p'\})] \quad (4.4.7.2.3-1)$$
- For initial normally consolidated soils (i.e., $s_p' = s_o'$):

$$S_c = [H_c / (1 + e_o)] [C_c \log (s_f' / s_p')] \quad (4.4.7.2.3-2)$$

If laboratory test results are expressed in terms of vertical strain (ϵ_v) consolidation settlement may be estimated using the following:

- For initial overconsolidated soils (i.e., $s_p' > s_o'$):

$$S_c = H_c [C_{re} \log (s_p' / s_o') + C_{ce} \log (s_f' / s_p')] \quad (4.4.7.2.3-3)$$
- For initial normally consolidated soils (i.e., $s_p' = s_o'$):

$$S_c = H_c C_{ce} \log (s_f' / s_p') \quad (4.4.7.2.3-4)$$

Refer to Figures 4.4.7.2.3A and 4.4.7.2.3B for the definition of terms used in the equations.

To account for the decreasing stress with increased depth below a footing, and variations in soil compressibility with depth, the compressible layer should be divided into vertical increments (i.e., typically 5 to 10

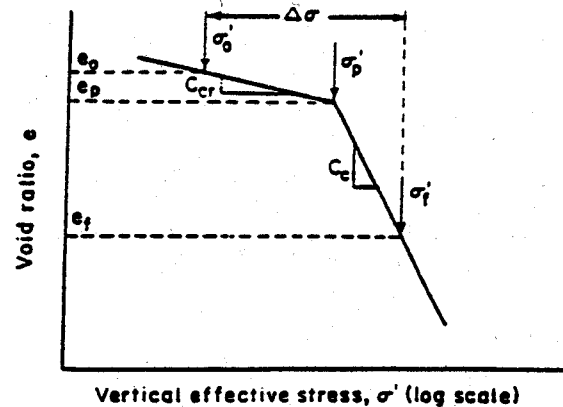

FIGURE 4.4.7.2.3A Typical Consolidation Compression Curve for Overconsolidated Soil-Void Ratio Versus Vertical Effective Stress EPRI (1983)

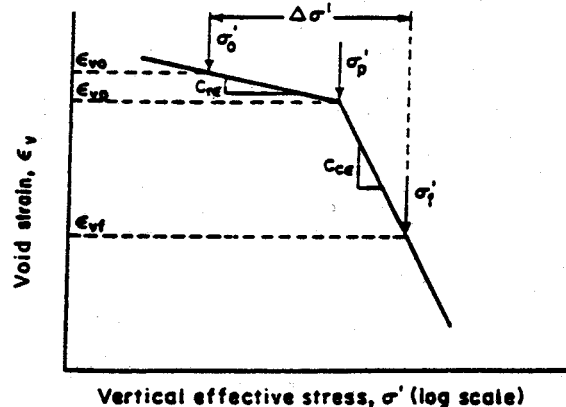

FIGURE 4.4.7.2.3B Typical Consolidation Compression Curve for Overconsolidated Soil-Void Strain Versus Vertical Effective Stress

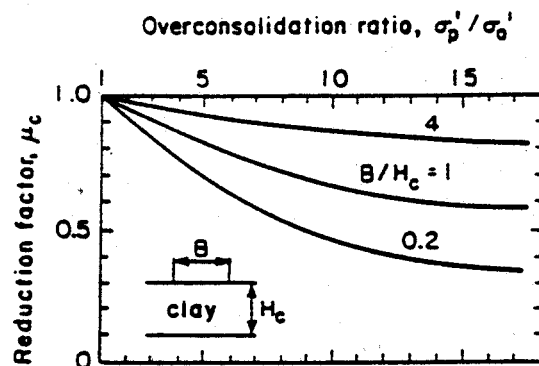

FIGURE 4.4.7.2.3C Reduction Factor to Account for Effects of Three-Dimensional Consolidation Settlement EPRI (1983)

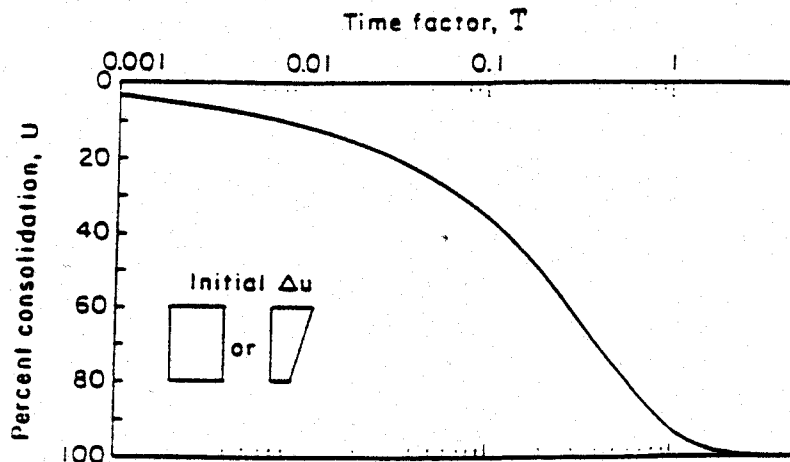

FIGURE 4.4.7.2.3D Percentage of Consolidation as a Function of Time Factor, T
EPRI (1983)

feet for most normal width footings for highway applications), and the consolidation settlement of each increment analyzed separately. The total value of S_c is the summation of S_c for each increment.

If the footing width is small relative to the thickness of the compressible soil, the effect of three-dimensional (3-D) loading may be considered using the following:

$$S_{c(3-D)} = \mu_c S_{c(1-D)} \quad (4.4.7.2.3-5)$$

Refer to Figure 4.4.7.2.3C for values of μ_c .

The time (t) to achieve a given percentage of the total estimated 1-D consolidation settlement may be estimated using the following:

$$t = TH_d^2/c_v \quad (4.4.7.2.3-6)$$

Refer to Figure 4.4.7.2.3D for values of T for constant and linearly varying excess pressure distributions. See Winterkorn and Fang (1975) for values of T for other excess pressure distributions. Values of c_v may be estimated from the results of laboratory consolidation testing of undisturbed soil samples or from in-situ measurements using devices such as a piezoprobe or piezocone.

4.4.7.2.4 Secondary Settlement

Secondary settlement of footings on cohesive soil may be estimated using the following:

$$S_c = C_{\alpha\epsilon} H_c \log(t_2/t_1) \quad (4.4.7.2.4-1)$$

t_1 is the time when secondary settlement begins (typically at a time equivalent to 90-percent average degree of consolidation), and t_2 is an arbitrary time which could represent the service life of the structure. Values of $C_{\alpha\epsilon}$ may be estimated from the results of consolidation testing of undisturbed soil samples in the laboratory.

4.4.7.2.5 Deleted

4.4.7.3 Deleted

4.4.8 Geotechnical Design on Rock

Spread footings supported on rock shall be designed to support the design loads with adequate bearing and structural capacity and with tolerable settlements in conformance with Articles 4.4.8 and 4.4.11. For footings on rock, the location of the resultant of pressure (R) on the base of footings shall be maintained within $B/4$ of the center of the footing.

The bearing capacity and settlement of footings on rock is influenced by the presence, orientation and condition of discontinuities, weathering profiles, and other similar features. The methods used for design of footings on rock should consider these factors as they apply at a particular site, and the degree to which they should be incorporated in the design.

For footings on competent rock, reliance on simple and direct analyses based on uniaxial compressive rock strengths and RQD may be applicable. Competent rock is defined as a rock mass with discontinuities that are tight

or open not wider than $\frac{1}{8}$ inch. For footings on less competent rock, more detailed investigations and analyses should be used to account for the effects of weathering, the presence and condition of discontinuities, and other geologic factors.

4.4.8.1 Bearing Capacity

4.4.8.1.1 Footings on Competent Rock

The allowable bearing capacity for footings supported on level surfaces in competent rock may be determined using Figure 4.4.8.1.1 A (Peck, et al. 1974). In no instance shall the maximum allowable bearing capacity exceed the allowable bearing stress in the concrete. The RQD used in Figure 4.4.8.1.1 A shall be the average RQD for the

rock within a depth of B below the base of the footing, where the RQD values are relatively uniform within that interval. If rock within a depth of 0.5B below the base of the footing is of poorer quality, the RQD of the poorer rock shall be used to determine q_{all} .

4.4.8.1.2 Footings on Broken or Jointed Rock

The design of footings on broken or jointed rock must account for the condition and spacing of joints and other discontinuities. The ultimate bearing capacity of footings on broken or jointed rock may be estimated using the following relationship:

$$q_{ult} = N_{ms}C_o \quad (4.4.8.1.2-1)$$

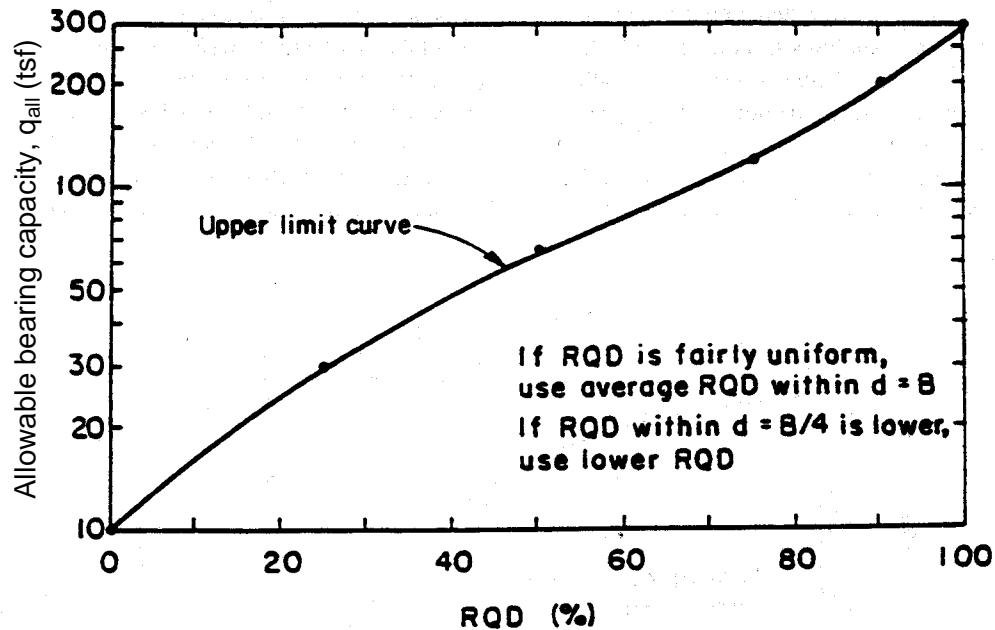

Note:

q_{all} shall not exceed the unconfined compressive strength of the rock or 0.595 f'_c of the concrete.

FIGURE 4.4.8.1.1A Allowable Contact Stress for Footings on Rock with Tight Discontinuities
Peck, et al. (1974)

TABLE 4.4.8.1.2A Values of Coefficient N_{ms} for Estimation of the Ultimate Bearing Capacity of Footings on Broken or Jointed Rock (Modified after Hoek, (1983))

Rock Mass Quality	General Description	RMR ⁽¹⁾ Rating	NGI ⁽²⁾ Rating	RQD ⁽³⁾ (%)	N_{ms} ⁽⁴⁾				
					A	B	C	D	E
Excellent	Intact rock with joints spaced > 10 feet apart	100	500	95-100	3.8	4.3	5.0	5.2	6.1
Very good	Tightly interlocking, undisturbed rock with rough unweathered joints spaced 3 to 10 feet apart	85	100	90-95	1.4	1.6	1.9	2.0	2.3
Good	Fresh to slightly weathered rock, slightly disturbed with joints spaced 3 to 10 feet apart	65	10	75-90	0.28	0.32	0.38	0.40	0.46
Fair	Rock with several sets of moderately weathered joints spaced 1 to 3 feet apart	44	1	50-75	0.049	0.056	0.066	0.069	0.081
Poor	Rock with numerous weathered joints spaced 1 to 20 inches apart with some gouge	23	0.1	25-50	0.015	0.016	0.019	0.020	0.024
Very poor	Rock with numerous highly weathered joints spaced < 2 inches apart	3	0.01	< 25	Use q_{ult} for an equivalent soil mass				

⁽¹⁾Geomechanics Rock Mass Rating (RMQ) System—Bieniawski, 1988.

⁽²⁾Norwegian Geotechnical Institute (NGI) Rock Mass Classification System, Barton, et al., 1974.

⁽³⁾Range of RQD values provided for general guidance only; actual determination of rock mass quality should be based on RMR or NGI rating systems.

⁽⁴⁾Value of N_{ms} as a function of rock type; refer to Table 4.4.8.1.2B for typical range of values of C_o for different rock type in each category.

Refer to Table 4.4.8.1.2A for values of N_{ms} . Values of C_o should preferably be determined from the results of laboratory testing of rock cores obtained within 2B of the base of the footing. Where rock strata within this interval are variable in strength, the rock with the lowest capacity should be used to determine q_{ult} . Alternatively, Table 4.4.8.1.2B may be used as a guide to estimate C_o . For rocks defined by very poor quality, the value of q_{ult} should be determined as the value of q_{ult} for an equivalent soil mass.

4.4.8.1.3 Factors of Safety

Spread footings on rock shall be designed for Group 1 loadings using a minimum factor of safety (FS) of 3.0 against a bearing capacity failure.

4.4.8.2 Settlement

4.4.8.2.1 Footings on Competent Rock

For footings on competent rock, elastic settlements will generally be less than $\frac{1}{2}$ inch when footings are designed in accordance with Article 4.4.8.1.1. When elastic settlements of this magnitude are unacceptable or when the rock is not competent, an analysis of settlement based on rock mass characteristics must be made. For rock masses which have time-dependent settlement characteristics, the procedure in Article 4.4.7.2.3 may be followed to determine the time-dependent component of settlement.

TABLE 4.4.8.1.2B Typical Range of Uniaxial Compressive Strength (C_o) as a Function of Rock Category and Rock Type

Rock Category	General Description	Rock Type	$C_o^{(1)}$	
			(ksf)	(psi)
A	Carbonate rocks with well-developed crystal cleavage	Dolostone	700- 6,500	4,800- 45,000
		Limestone	500- 6,000	3,500- 42,000
		Carbonatite	800- 1,500	5,500- 10,000
		Marble	800- 5,000	5,500- 35,000
		Tactite-Skarn	2,700- 7,000	19,000- 49,000
B	Lithified argillaceous rock	Argillite	600- 3,000	4,200- 21,000
		Claystone	30- 170	200- 1,200
		Marlstone	1,000- 4,000	7,600- 28,000
		Phyllite	500- 5,000	3,500- 35,000
		Siltstone	200- 2,500	1,400- 17,000
		Shale ⁽²⁾	150- 740	1,000- 5,100
		Slate	3,000- 4,400	21,000- 30,000
C	Arenaceous rocks with strong crystals and poor cleavage	Conglomerate	700- 4,600	4,800- 32,000
		Sandstone	1,400- 3,600	9,700- 25,000
		Quartzite	1,300- 8,000	9,000- 55,000
D	Fine-grained igneous crystalline rock	Andesite	2,100- 3,800	14,000- 26,000
		Diabase	450-12,000	3,100- 83,000
E	Coarse-grained igneous and metamorphic crystalline rock	Amphibolite	2,500- 5,800	17,000- 40,000
		Gabbro	2,600- 6,500	18,000- 45,000
		Gneiss	500- 6,500	3,500- 45,000
		Granite	300- 7,000	2,100- 49,000
		Quartzdiorite	200- 2,100	1,400- 14,000
		Quartzmonzonite	2,700- 3,300	19,000- 23,000
		Schist	200- 3,000	1,400- 21,000
Syenite	3,800- 9,000	26,000- 62,000		

⁽¹⁾Range of Uniaxial Compressive Strength values reported by various investigations.

⁽²⁾Not including oil shale.

4.4.8.2.2 Footings on Broken or Jointed Rock

Where the criteria for competent rock are not met, the influence of rock type, condition of discontinuities and degree of weathering shall be considered in the settlement analysis.

The elastic settlement of footings on broken or jointed rock may be determined using the following:

- For circular (or square) footings;

$$\rho = q_o (1 - \nu^2) r I_p / E_m, \text{ with } I_p = (\quad) / \beta_z \quad (4.4.8.2.2-1)$$

- For rectangular footings;

$$\rho = q_o (1 - \nu^2) B I_p / E_m, \text{ with } I_p = (L/B)^{1/2} / \beta_z \quad (4.4.8.2.2-2)$$

Values of I_p may be computed using the β_z values presented in Table 4.4.7.2.2B from Article 4.4.7.2.2 for rigid footings. Values of Poisson's ratio (ν) for typical rock types are presented in Table 4.4.8.2.2A. Determination of the rock mass modulus (E_m) should be based on the results of in-situ and laboratory tests. Alternatively, values of E_m may be estimated by multiplying the intact rock modulus (E_o) obtained from uniaxial compression tests by a reduction factor (α_E) which accounts for frequency of discontinuities by the rock quality designation (RQD), using the following relationships (Gardner, 1987):

**TABLE 4.4.8.2.2A Summary of Poisson's Ratio for Intact Rock
Modified after Kulhawy (1978)**

Rock Type	No. of Values	No. of Rock Types	Poisson's Ratio, ν			Standard Deviation
			Maximum	Minimum	Mean	
Granite	22	22	0.39	0.09	0.20	0.08
Gabbro	3	3	0.20	0.16	0.18	0.02
Diabase	6	6	0.38	0.20	0.29	0.06
Basalt	11	11	0.32	0.16	0.23	0.05
Quartzite	6	6	0.22	0.08	0.14	0.05
Marble	5	5	0.40	0.17	0.28	0.08
Gneiss	11	11	0.40	0.09	0.22	0.09
Schist	12	11	0.31	0.02	0.12	0.08
Sandstone	12	9	0.46	0.08	0.20	0.11
Siltstone	3	3	0.23	0.09	0.18	0.06
Shale	3	3	0.18	0.03	0.09	0.06
Limestone	19	19	0.33	0.12	0.23	0.06
Dolostone	5	5	0.35	0.14	0.29	0.08

**TABLE 4.4.8.2.2B Summary of Elastic Moduli for Intact Rock
Modified after Kulhawy (1978)**

Rock Type	No. of Values	No. of Rock Types	Elastic Modulus, E_o (psi x 10^6) ⁽¹⁾			Standard Deviation
			Maximum	Minimum	Mean	
Granite	26	26	14.5	0.93	7.64	3.55
Diorite	3	3	16.2	2.48	7.45	6.19
Gabbro	3	3	12.2	9.80	11.0	0.97
Diabase	7	7	15.1	10.0	12.8	1.78
Basalt	12	12	12.2	4.20	8.14	2.60
Quartzite	7	7	12.8	5.29	9.59	2.32
Marble	14	13	10.7	0.58	6.18	2.49
Gneiss	13	13	11.9	4.13	8.86	2.31
Slate	11	2	3.79	0.35	1.39	0.96
Schist	13	12	10.0	0.86	4.97	3.18
Phyllite	3	3	2.51	1.25	1.71	0.57
Sandstone	27	19	5.68	0.09	2.13	1.19
Siltstone	5	5	4.76	0.38	2.39	1.65
Shale	30	14	5.60	0.001	1.42	1.45
Limestone	30	30	13.0	0.65	5.70	3.73
Dolostone	17	16	11.4	0.83	4.22	3.44

⁽¹⁾1.0 x 10⁶ psi = 1.44 x 10⁵ ksf.

$$E_m = \alpha_E E_o \quad (4.4.8.2.2-3)$$

$$\alpha_E = 0.0231 \text{ (RQD)} - 1.32 \geq 0.15 \quad (4.4.8.2.2-4)$$

For preliminary design or when site-specific test data cannot be obtained, guidelines for estimating values of E_o (such as presented in Table 4.4.8.2.2B or Figure 4.4.8.2.2A) may be used. For preliminary analyses or for final design when in-situ test results are not available, a value of $\alpha_E = 0.15$ should be used to estimate E_m .

+ 4.4.8.2.3 Deleted

4.4.9 Overall Stability

The overall stability of footings, slopes, and foundation soil or rock shall be evaluated for footings located on or near a slope by limiting equilibrium methods of analysis which employ the Modified Bishop, simplified Janbu, Spenser or other generally accepted methods of slope stability analysis. Where soil and rock parameters and ground water levels are based on in-situ and/or laboratory tests, the minimum factor of safety shall be 1.3 (or 1.5 where abutments are supported above a slope). Otherwise, the minimum factor of safety shall be 1.5 (or 1.8 where abutments are supported above a retaining wall).

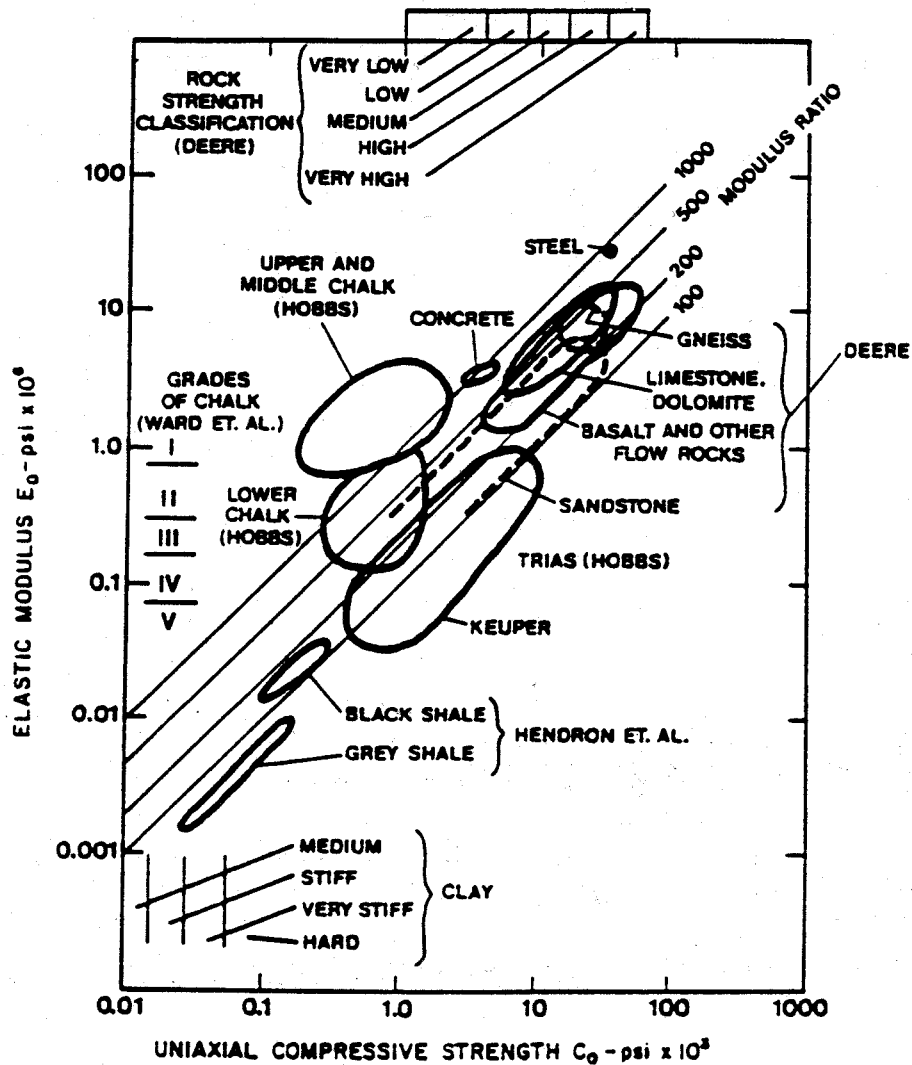

FIGURE 4.4.8.2.2A Relationship Between Elastic Modulus and Uniaxial Compressive Strength for Intact Rock Modified after Deere (1968)



+ 4.4.10 Deleted

4.4.11 Structural Design

4.4.11.1 Loads and Reactions

4.4.11.1.1 Action of Loads and Reactions

Footings shall be considered as under the action of downward forces, due to the superimposed loads, resisted by an upward pressure exerted by the foundation materials and distributed over the area of the footings as determined by the eccentricity of the resultant of the downward forces. Where piles are used under footings, the upward reaction of the foundation shall be considered as a series of concentrated loads applied at the pile centers, each pile being assumed to carry the computed portion of the total footing load.

4.4.11.1.2 Isolated and Multiple Footing Reactions

When a single isolated footing supports a column, pier or wall, the footing shall be assumed to act as a cantilever. When footings support more than one column, pier, or wall, the footing slab shall be designed for the actual conditions of continuity and restraint.

4.4.11.2 Moments

4.4.11.2.1 Critical Section

External moment on any section of a footing shall be determined by passing a vertical plane through the footing, and computing the moment of the forces acting over the entire area of footing on one side of that vertical plane.

+ The critical section for bending shall be taken at the face
+ of column, pier, wall or at edge of hinge. In the case of
+ columns that are not square or rectangular, the critical
section shall be taken at the side of the concentric square
of equivalent area. For footings under masonry walls, the
critical section shall be taken as halfway between the
middle and edge of the wall. For footings under metallic
column bases, the critical section shall be taken as half-
way between the column face and the edge of the metallic
base. Reinforcement for footing flexural moments shall
+ be in accordance with Article 8.16.3.

4.4.11.2.2 Distribution of Reinforcement

Reinforcement of one-way and two-way square footings shall be distributed uniformly across the entire width of footing.

In two-way rectangular footings, reinforcement shall
be distributed as follows: +

Reinforcement in the long direction shall be distrib-
uted uniformly across entire width of footing. +

For reinforcement in the long direction, the area of
reinforcement to be placed shall be not less than $2L/(L+S)$
times the area of reinforcement required to resist the
applied moment and shall be distributed uniformly over
the entire width. L and S equal the lengths of the long side
and short side of the footing, respectively. +

The minimum top flexural reinforcement for footings
shall be that required to resist loads which cause tension
in the top fiber, Article 8.17.1 or Article 8.20 whichever
controls. +

4.4.11.3 Shear

4.4.11.3.1 Computation of shear in footings, and
location of critical section, shall be in accordance with
Article 8.15.5.6 or 8.16.6.6. Location of critical section
shall be measured from the face of column, pier, wall, or
at edge of hinge, for footings supporting a column, pier,
or wall. For footings supporting a column or pier with
metallic base plate, the critical section shall be measured
from the location defined in Article 4.4.11.2.1. +

4.4.11.3.2 For footings supported on piles, shear
on the critical section shall be in accordance with the
following, where d_p is the diameter of a round pile or depth
of H pile at footing base: +

- (a) Entire reaction from any pile whose center is located $d_p/2$ or more outside the critical section shall be considered as producing shear on that section.
- (b) Reaction from any pile whose center is located $d_p/2$ or more inside the critical section shall be considered as producing no shear on that section.
- (c) For intermediate positions of pile center, the portion of the pile reaction to be considered as producing shear on the critical section shall be based on linear interpolation between full value at

$d_p/2$ outside the section and zero value at $d_p/2$ inside the section.

+ **4.4.11.3.3 Minimum Reinforcement**

+ The minimum shear reinforcement for column footings shall be vertical No. 5 bars at 12 inch spacing in each direction in a band between “ d ” of the footing from the column surface and 6 inches maximum from the column reinforcement. Shear bars shall be hooked around the top and bottom flexure reinforcement in the footing.

4.4.11.4 Development of Reinforcement

4.4.11.4.1 Development Length

Computation of development of reinforcement in footings shall be in accordance with Articles 8.24 through 8.32.

4.4.11.4.2 Critical Section

Critical sections for development of reinforcement shall be assumed at the same locations as defined in Article 4.4.11.2 and at all other vertical planes where changes in section, or reinforcement occur. See also Article 8.24.1.5.

4.4.11.5 Transfer of Force at Base of Column

4.4.11.5.1 Transfer of Force

All forces and moments applied at base of column or pier shall be transferred to top of footing by bearing on concrete and by reinforcement.

+ Fixed bases shall meet the requirements of this Article. Pinned bases shall meet the requirements of Article 8.16.4.6.

4.4.11.5.2 Lateral Forces

Lateral forces shall be transferred to supporting footing in accordance with shear-transfer provisions of Articles 8.15.5.4 or 8.16.6.4.

4.4.11.5.3 Bearing

Bearing on concrete at contact surface between supporting and supported member shall not exceed concrete bearing strength for either surface as given in Articles 8.15.2 or 8.16.7.

4.4.11.5.4 Reinforcement

Reinforcement shall be provided across interface between supporting and supported member either by extending main longitudinal reinforcement into footings or by dowels. Reinforcement across interface shall be sufficient to satisfy all of the following:

- Reinforcement shall be provided to transfer all force that exceeds concrete bearing strength in supporting or supported member.
- If required loading conditions include uplift, total tensile force shall be resisted by reinforcement.
- Area of reinforcement shall not be less than 0.005 times gross area of supported member, with a minimum of four bars.

4.4.11.5.5 Dowel Size

Diameter of dowels, if used, shall not exceed diameter of longitudinal reinforcement by more than 0.15 inch.

4.4.11.5.6 Development Length

For transfer of force by reinforcement, development of reinforcement in supporting and supported member shall be in accordance with Articles 8.24 through 8.32.

4.4.11.5.7 Splicing

At footings, No. 14 and 18 main longitudinal reinforcement, in compression only, may be lap spliced with footing dowels to provide the required area, but not less than that required by Article 4.4.11.5.4. Dowels shall not be larger than No. 11 and shall extend into the column a distance of not less than the development length of the No. 14 or 18 bars or the splice length of the dowels, whichever is greater; and into the footing a distance of not less than the development length of the dowels.

The bars shall be terminated in the footings with a standard hook. Lap splices shall not be used. +

4.4.11.6 Unreinforced Concrete Footings

4.4.11.6.1 Design Stress

Design stresses in plain concrete footings or pedestals shall be computed assuming a linear stress distribution. For footings and pedestals cast against soil, effective thickness used in computing stresses shall be taken as the overall thickness minus 3 inches. Extreme fiber stress in tension shall not exceed that specified in Article 8.15.2.1.1. Bending need not be considered unless projection of footing from face to support member exceeds footing thickness.

4.4.11.6.2 Pedestals

The ratio of unsupported height to average least lateral dimension of plain concrete pedestals shall not exceed 3.

4.5 DRIVEN PILES

4.5.1 General

The provisions of this article shall apply to the design of axially and laterally loaded driven piles in soil or extending through soil to rock.

4.5.1.1 Application

Piling may be considered when footings cannot be founded on rock, or on granular or stiff cohesive soils within a reasonable depth. At locations where soil conditions would normally permit the use of spread footings but the potential for scour exists, piles may be used as a protection against scour. Piles may also be used where an unacceptable amount of settlement of spread footings may occur.

4.5.1.2 Materials

Piles may be structural steel sections, steel pipe, precast concrete, cast-in-place concrete, prestressed concrete, timber, or a combination of materials. In every case, materials shall be supplied in accordance with the provisions of this Article.

+ 4.5.1.3 Deleted

4.5.1.4 Lateral Tip Restraint

No piling shall be used to penetrate a soft or loose upper stratum overlying a hard or firm stratum unless the piles penetrate the hard or firm stratum by a sufficient distance to fix the ends against lateral movement of the pile tip. Driving points or shoes may be necessary to accomplish this penetration.

4.5.1.5 Estimated Lengths

Estimated pile lengths for each substructure shall be shown on the plans and shall be based upon careful evaluation of available subsurface information, static and lateral capacity calculations, and/or past experience.

4.5.1.6 Estimated and Minimum Tip Elevation

Estimated and minimum pile tip elevations for each substructure should be shown on the contract plans. Estimated pile tip elevations shall reflect the elevation where the required ultimate pile capacity can be obtained. Minimum pile tip elevations shall reflect the penetration required to support lateral pile loads (including scour considerations where appropriate) and/or penetration of overlying, unsuitable soil strata.

4.5.1.7 Deleted

4.5.1.8 Test Piles

Test piles shall be considered for each substructure unit (See Article 7.1.1 for definition of substructure unit) to determine pile installation characteristics, evaluate pile capacity with depth and to establish contractor pile order lengths. Piles may be tested by static loading, dynamic testing, conducting driveability studies, or a combination thereof, based upon the knowledge of subsurface conditions. The number of test piles required may be increased in non-uniform subsurface conditions. Test piles may not be required where previous experience exists with the same pile type and ultimate pile capacity in similar subsurface conditions.

4.5.2 Pile Types

Piles shall be classified as “friction” or “end bearing” or a combination of both according to the manner in which load transfer is developed.

4.5.2.1 Friction Piles

A pile shall be considered to be a friction pile if the major portion of support capacity is derived from soil resistance mobilized along the side of the embedded pile.

4.5.2.2 End Bearing Piles

A pile shall be considered to be an end bearing pile if the major portion of support capacity is derived from the resistance of the foundation material on which the pile tip rests.

4.5.2.3 Combination Friction and End Bearing Piles

Under certain soil conditions and for certain pile materials, the bearing capacity of a pile may be considered as the sum of the resistance mobilized on the embedded shaft and that developed at the pile tip, even though the forces that are mobilized simultaneously are not necessarily maximum values.

4.5.2.4 Batter Piles

When the lateral resistance of the soil surrounding the piles is inadequate to counteract the horizontal forces transmitted to the foundation, or when increased rigidity of the entire structure is required, batter piles should be used in the foundation. Where negative skin friction loads are expected, batter piles should be avoided, and an alternate method of providing lateral restraint should be used.

4.5.3 Notations

The following notations shall apply for the design of driven pile foundations:

- A_s = Area of pile circumference (ft²)
- A_t = Area of pile tip (ft²)
- B = Pile diameter or width (ft)
- f'_c = Concrete compression strength (ksi)
- f_{pc} = Concrete compression stress due to prestressing after all losses (ksi)
- FS = Factor of safety (dim)
- F_y = Yield strength of steel (ksi)
- L = Pile length (ft)
- Q_{all} = Design capacity (k)
- Q_s = Ultimate shaft resistance (k)
- Q_t = Ultimate tip resistance (k)

- Q_{ult} = Ultimate pile capacity (k)
- r_s = Unit side resistance (ksi)
- R_s = Side resistance (ksi)
- r_t = Unit tip resistance (ksi)
- R_t = Tip resistance (k)
- ρ = Percentage of reinforcement (dim)
- σ_a = Allowable stress (ksi)

The notations for dimension units include the following: dim = Dimensionless; ft = foot; square feet = ft²; k = kip; ksi = kip/in² and in. = inch. The dimensional units provided with each notation are presented for illustration only to demonstrate a dimensionally correct combination of units for the footing capacity procedures presented herein. If other units are used, the dimensional correctness of the equations shall be confirmed.

4.5.4 Design Terminology

Refer to Figure 4.5.4A for terminology used in the design of driven pile foundations.

4.5.5 Selection of Soil and Rock Properties

Soil and rock properties defining the strength and compressibility characteristics of the foundation materials, are required for driven pile design. Refer to Article 4.3 for guidelines for subsurface exploration to obtain soil and rock properties.

4.5.6 Selection of Design Pile Capacity

The design pile capacity is the maximum load the pile shall support with tolerable movement. In determining the design pile capacity, the following items shall be considered:

- Ultimate geotechnical capacity; and
- Structural capacity of the pile section.

4.5.6.1 Ultimate Geotechnical Capacity

The ultimate axial capacity of a driven pile shall be determined from:

$$Q_{ult} = Q_s + Q_t \quad (4.5.6.1-1)$$

The allowable design axial capacity shall be determined from:

$$Q_{all} = Q_{ult}/FS \quad (4.5.6.1-2)$$

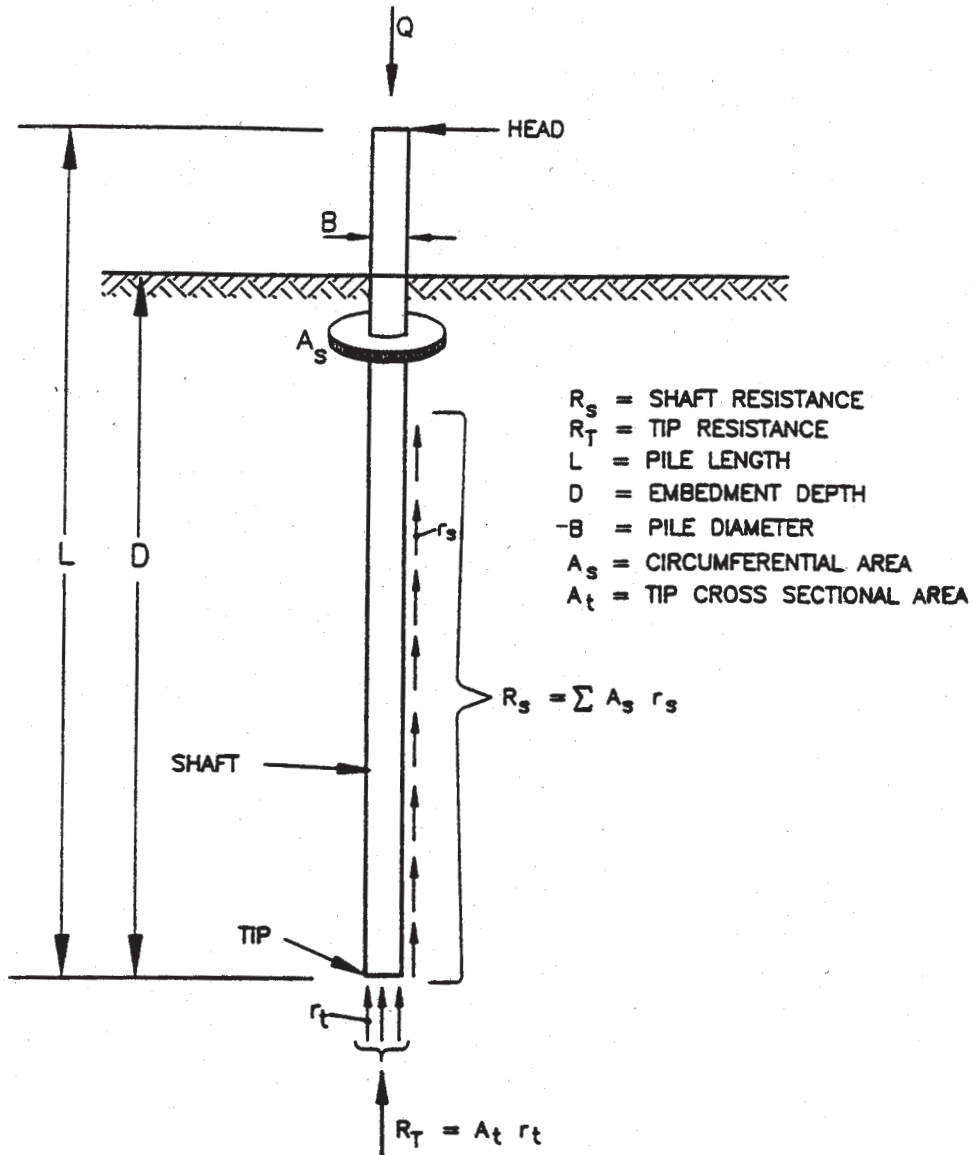

FIGURE 4.5.4A Design Terminology for Driven Pile Foundations

4.5.6.1.1 Factors Affecting Axial Capacity

In determining the design axial capacity, consideration shall be given to:

- The difference between the supporting capacity of a single pile and that of a group of piles;
- The capacity of an underlying strata to support the load of the pile group;
- The effects of driving piles on adjacent structures or slopes;
- The possibility of scour and its effect on axial and lateral capacity;
- The effects of negative skin friction or downdrag loads from consolidating soil and the effects of uplift loads from expansive or swelling soils;
- The influence of construction techniques such as augering or jetting on capacity; and
- The influence of fluctuations in the elevation of the ground water table on capacity.

4.5.6.1.2 Axial Capacity in Cohesive Soils

The ultimate axial capacity of piles in cohesive soils may be calculated using a total stress method (e.g., Tomlinson, 1957) for undrained loading conditions, or an effective stress method (e.g., Meyerhof, 1976) for drained loading conditions. The axial capacity may also be calculated from in-situ testing methods such as the cone penetration (e.g., Schmertmann, 1978) or pressuremeter tests (e.g., Baguelin, 1978).

4.5.6.1.3 Axial Capacity in Cohesionless Soils

The ultimate axial capacity of piles in cohesionless soils may be calculated using an empirical effective stress method (e.g., Nordlund, 1963) or from in-situ testing methods and analysis such as the cone penetration (e.g., Schmertmann, 1978) or pressuremeter tests (e.g., Baguelin, 1978).

4.5.6.1.4 Axial Capacity on Rock

For piles driven to competent rock, the structural capacity in Article 4.5.7 will generally govern the design axial capacity. For piles driven to weak rock such as shale and mudstone or poor quality weathered rock, a static

load test is recommended. Pile relaxation should be considered in certain kinds of rock when performing load tests.

4.5.6.2 Factor of Safety Selection

The required nominal resistance is twice the design service load. The Division of Structural Foundations will determine the geotechnical capacity to meet or exceed the required nominal resistance. The safety margin between the required nominal resistance and the ultimate geotechnical capacity shall be determined by the Division of Structural Foundations considering the uncertainties of the ultimate soil capacity determination and pile installation control.

4.5.6.3 Deleted

4.5.6.4 Group Pile Loading

Group pile capacity should be determined as the product of the group efficiency, number of piles in the group, and the capacity of a single pile. In general, a group efficiency value of 1.0 should be used; however, for friction piles in cohesive soil, a group efficiency value less than 1.0 may be required depending upon the center-to-center spacing of the piles. The Division of Structural Foundations should be consulted to determine the efficiency factors for friction piles in cohesive soils.

4.5.6.5 Lateral Loads on Piles

The design of laterally loaded piles is usually governed by lateral movement criteria. The design of laterally loaded piles shall account for the effects of soil/rock structure interaction between the pile and ground (e.g., Reese, 1984). Methods of analysis evaluating the ultimate capacity or deflection of laterally loaded piles (e.g., Broms, 1964a and 1964b; Singh, et al., 1971) may be used for preliminary design only as a means to evaluate appropriate pile sections.

4.5.6.5.1 Lateral Resistance

Lateral resistance of piles fully embedded in soil with standard penetration resistance value, N , of 10 and with a $1/4$ inch maximum horizontal deflection under Service Load shall be:



- + CIDH Concrete (16") 13 kips
- + Driven Concrete(15" or 14") 13kips
- + Driven Concrete (12") 5 kips
- + Steel (12" or 10" flange) 5 kips
- + Steel (8" flange) 4 kips
- + Timber 5 kips

+ The lateral resistance of piles not within these criteria shall be determined by geotechnical analysis and structural adequacy of the pile.

+ At bent and pier footings the number of piles required for lateral pile resistance shall not be governed by Group VII loads.

+ The horizontal component of a battered pile's axial load may be added to the lateral resistance.

4.5.6.6 Uplift Loads on Pile

The uplift design capacity of single piles and pile groups shall be determined in accordance with Articles 4.5.6.6.1 and 4.5.6.6.2 respectively. Proper provision shall be made for anchorage of the pile into the pile cap.

4.5.6.6.1 Single Pile

+ Friction piles may be considered to resist an intermittent but not sustained uplift. Uplift resistance may be equivalent to 40 percent of the allowable structural compressive load capacity. Adequate pile anchorage, tensile strength, and geotechnical capacity must be provided.

4.5.6.6.2 Pile Group

The uplift design capacity for a pile group shall be the lesser of: (1) The single pile uplift design capacity multiplied by the number of piles in the group, or (2) two-thirds of the effective weight of the pile group and the soils contained within a block defined by the perimeter of the group and the embedded length of the piles, or (3) one-half the effective weight of the pile group and the soil contained within a block defined by the perimeter of the group and the embedded pile length plus one-half the total soil shear on the peripheral surface of the group.

4.5.6.6.3 Seal Course

+ In seals, the bond between timber, steel, or concrete piles and surrounding concrete may be assumed to be 10 pounds per square inch. The total bond force used shall be no greater than the resistance of the pile to uplift.

4.5.6.7 Vertical Ground Movement

The potential for external loading on a pile by vertical ground movements shall be considered as part of the design. Vertical ground movements may result in negative skin friction or downdrag loads due to settlement of compressible soils or may result in uplift loads due to heave of expansive soils. For design purposes, the full magnitude of maximum vertical ground movement shall be assumed.

4.5.6.7.1 Negative Skin Friction

The potential for external loading on a pile by negative skin friction/downdrag due to settlement of compressible soil shall be considered as a part of the design. Evaluation of negative skin friction shall include a load-transfer method of analysis to determine the neutral point (i.e., point of zero relative displacement) and load distribution along shaft (e.g., Fellenius, 1984, Reese and O'Neill, 1988). Due to the possible time dependence associated with vertical ground movement, the analysis shall consider the effect of time on load transfer between the ground and shaft and the analysis shall be performed for the time period relating to the maximum axial load transfer to the pile. If necessary, negative skin friction loads that cause excessive settlement may be reduced by application of bitumen or other viscous coatings to the pile surfaces before installation.

4.5.6.7.2 Expansive Soil

Piles driven in swelling soils may be subjected to uplift forces in the zone of seasonal moisture change. Piles shall extend a sufficient distance into moisture-stable soils to provide adequate resistance to swelling uplift forces. In addition, sufficient clearance shall be provided between the ground surface and the underside of pile caps or grade beams to preclude the application of uplift loads at the pile cap. Uplift loads may be reduced by application of bitumen or other viscous coatings to the pile surface in the swelling zone.

4.5.6.8 Deleted

4.5.7 Structural Capacity of Pile Section

4.5.7.1 Load Capacity Requirements

Piles shall be designed as structural members capable of safely supporting all loads imposed on them by the structure or surrounding soil.

4.5.7.2 Piles Extending Above Ground Surface

For portions of piles in air or water, or in soil not capable of providing adequate lateral support throughout the pile length to prevent buckling, the structural design provisions for compression members of Sections 8, 9, 10, and 13 shall apply except: timber piles shall be designed in accordance with Article 13.5 using the allowable unit stresses given in Article 13.2 for lumber and in Table 4.5.7.3A.

4.5.7.3 Allowable Stresses in Piles

+ The maximum allowable stress on a pile shall not exceed the following limits in severe subsurface conditions.

+ Where pile damage or deterioration is possible, it may be prudent to use a lower stress level than the maximum allowable stress.

- + • For steel H-piles, and unfilled steel pipe piles, the maximum allowable stress shall not exceed $0.28F_y$ over the net cross-sectional area of the pile, not including the area of any tip reinforcement. Net section equals gross section less $1/16$ inch from all surfaces.
- + • For concrete filled steel pipe piles, the maximum allowable stress shall not exceed $0.28F_y + 0.40f'_c$ applied over the net cross-sectional area of the steel pipe and on the cross-sectional area of the concrete, respectively.
- + • For precast concrete piles, the maximum allowable stress shall not exceed $0.33 f'_c$ on the gross cross-sectional area of the concrete.
- + • For prestressed concrete piles fully embedded in soils providing lateral support, the maximum allowable stress shall not exceed $0.33 f'_c - 0.27f_{pe}$ on the gross cross-sectional area of the concrete.
- + • For round timber piles, the maximum allowable

stress shall not exceed the values in Table 4.5.7.3A for the pile tip area. For sawn timber piles, the values applicable to "wet condition" for allowable compression parallel to grain shall be used in accordance with Article 13.2.

TABLE 4.5.7.3A Allowable Working Stress for Round Timber Piles

Species	Allowable Unit Working Stress Compression Parallel to Grain for Normal Duration of Loading σ_a (psi)
Ash, white	1,200
Beech	1,300
Birch	1,300
Chestnut	900
Cypress, Southern	1,200
Cypress, Tidewater red	1,200
Douglas Fir, coast type	1,200
Douglas Fir, inland	1,100
Elm, rock	1,300
Elm, soft	850
Gum, black and red	850
Hemlock, Eastern	800
Hemlock, West Coast	1,000
Hickory	1,650
Larch	1,200
Maple, hard	1,300
Oak, red and white	1,100
Pecan	1,650
Pine, Lodgepole	800
Pine, Norway	850
Pine, Southern	1,200
Pine, Southern, dense	1,400
Poplar, yellow	800
Redwood	1,100
Spruce, Eastern	850
Tupelo	850

+ 4.5.7.4 Deleted

4.5.7.5 Scour

The probable depth of scour shall be determined by subsurface exploration and hydraulic studies as described in Article 4.3.5. If heavy scour is expected, consideration shall be given to designing the portion of the pile that would be exposed as a column. In all cases, the pile length shall be determined such that the design structural load may be safely supported entirely below the probable scour depth. The pile shall be of adequate cross-section to withstand the driving necessary to penetrate through the anticipated scour depth to the design embedment.

4.5.8 Protection Against Corrosion and Abrasion

Where conditions of exposure warrant, concrete encasement or other corrosion protection shall be used on steel piles and steel shells. Exposed steel piles or steel shells shall not be used in salt or brackish water, and only with caution in fresh water. Where the piling is exposed to the abrasive action of the bed load of materials, the section shall be increased in thickness or positive protection shall be provided.

4.5.9 Wave Equation Analysis

The constructability of the pile foundation design should be evaluated using a wave equation computer program. The wave equation should be used to confirm that the design pile section can be installed to the desired depth, ultimate capacity, and within the allowable driving stress levels specified in Article 4.5.11 using an appropriately sized driving system.

4.5.10 Dynamic Monitoring

Dynamic monitoring may be specified for piles installed in difficult subsurface conditions such as soils with obstructions and boulders, or a steeply sloping bedrock surface to evaluate compliance with structural pile capacity. Dynamic monitoring may also be considered for geotechnical capacity verification where the size of the project or other limitations deter static load testing.

4.5.11 Maximum Allowable Driving Stresses

Maximum allowable driving stresses in pile material for top driven piles shall not exceed the following limits:

Steel piles	0.90F _y (Compression) 0.90F _y (Tension)
Concrete piles	0.85 f' _c (Compression) 0.70F _y of Steel Reinforcement (Tension)
Prestressed concrete piles	0.85 f' _c - f _{pe} (Compression)
Normal environments	3√f' _c + f _{pe} (Tension)
	(f' _c and f _{pe} must be in psi. The resulting max stress is also in psi.)
Severe corrosive environments	f _{pe} (Tension)
Timber piles	3σ _a (Compression) 3σ _a (Tension)

Driving stresses may be estimated by performing wave equation analyses or by dynamic monitoring of force and acceleration at the pile head during pile driving.

4.5.12 Tolerable Movement

Tolerable axial and lateral displacement criteria for driven pile foundations shall be developed by the structural engineer consistent with the function and type of structure, fixity of bearings, anticipated service life, and consequences of unacceptable displacements on the structural performance. Driven pile displacement analyses shall be based on the results of in-situ and/or laboratory testing to characterize the load deformation behavior of the foundation materials.

4.5.13 Buoyancy

The effect of hydrostatic pressure shall be considered in the design as provided in Article 3.19.

4.5.14 Protection Against Deterioration

4.5.14.1 Steel Piles

A steel pile foundation design shall consider that steel piles may be subject to corrosion, particularly in fill soils, low ph soils (acidic) and marine environments. A field

electric resistivity survey, or resistivity testing and ph testing of soil and ground water samples should be used to evaluate the corrosion potential. Methods of protecting steel piling in corrosive environments include use of protective coatings, cathodic protection, and increased pile steel area.

4.5.14.2 Concrete Piles

A concrete pile foundation design shall consider that deterioration of concrete piles can occur due to sulfates in soil, ground water, or sea water; chlorides in soils and chemical wastes; acidic ground water and organic acids. Laboratory testing of soil and ground water samples for sulfates and ph is usually sufficient to assess pile deterioration potential. A full chemical analysis of soil and ground water samples is recommended when chemical wastes are suspected. Methods of protecting concrete piling can include dense impermeable concrete, sulfate resisting portland cement, minimum cover requirements for reinforcing steel, and use of epoxies, resins, or other protective coatings.

4.5.14.3 Timber Piles

A timber pile foundation design shall consider that deterioration of timber piles can occur due to decay from wetting and drying cycles or from insects or marine borers. Methods of protecting timber piling include pressure treating with creosote or other wood preservers.

4.5.15 Spacing, Clearances, and Embedment

4.5.15.1 Pile Footings

+ Footings shall be proportioned to provide the required
+ minimum spacing, clearance and embedment of piles.

4.5.15.1.1 Pile Spacing

+ The minimum center to center spacing of piles shall be
+ two times either the diameter or the maximum dimension
+ of the pile, but not less than 3 feet. The spacing shall be
+ increased when required by subsurface conditions.

+ The minimum distance from the center of the pile to the
+ nearest edge of the footing shall be equal to either the
+ diameter or the maximum dimension of the pile, but not
+ less than 1 foot 6 inches.

4.5.15.1.2 Minimum Projection into CAP +

Piles shall be embedded into concrete footings as
follows: concrete piles –3 inches; steel piles –5 inches;
timber piles –8 inches. +

4.5.15.2 Bent Caps

Piles shall be embedded into concrete bent caps as
follows: concrete piles –1 inch; steel piles –5 inches;
timber piles –8 inches. +

4.5.16 Precast Concrete Piles

4.5.16.1 Size and Shape

Precast concrete piles shall be of approved size and shape but may be either of uniform section or tapered. In general, tapered piling shall not be used for trestle construction except for the portion of the pile which lies below the ground line; nor shall tapered piles be used in any location where the piles are to act as columns.

4.5.16.2 Minimum Area

In general, concrete piles shall have a cross-sectional area, measured above the taper, of not less than 98 square inches. In saltwater a minimum cross-sectional area of 140 square inches shall be used. If a square section is employed, the corners shall be chamfered at least 1 inch.

4.5.16.3 Minimum Diameter of Tapered Piles

The diameter of tapered piles measured at the point shall be not less than 8 inches. In all cases the diameter shall be considered as the least dimension through the center.

4.5.16.4 Driving Points

Piles preferably shall be cast with a driving point and, for hard driving, preferably shall be shod with a metal shoe of approved pattern.

4.5.16.5 Vertical Reinforcement

Vertical reinforcement shall consist of not less than four bars spaced uniformly around the perimeter of the pile, except that if more than four bars are used, the number may be reduced to four in the bottom 4 feet of the

pile. The amount of reinforcement shall be at least 1 1/2 percent of the total section measured above the taper.

4.5.16.6 Spiral Reinforcement

The full length of vertical steel shall be enclosed with spiral reinforcement or equivalent hoops. The spiral reinforcement at the ends of the pile shall have a pitch of 3 inches and gage of not less than No. 5 (U.S. Steel Wire Gage). In addition, the top 6 inches of the pile shall have five turns of spiral winding at 1-inch pitch. For the remainder of the pile, the lateral reinforcement shall be a No. 5 gage spiral with not more than 6-inch pitch, or 1/4-inch round hoops spaced on not more than 6-inch centers.

4.5.16.7 Reinforcement Cover

The reinforcement shall be placed at a clear distance from the face of the pile of not less than 2 inches and, when piles are used in saltwater or alkali soils, this clear distance shall not be less than 3 inches.

4.5.16.8 Splices

Piles may be spliced provided that the splice develops the full strength of the pile. Splices should be detailed on the contract plans. Any alternative method of splicing that provides equal results may be considered for approval.

4.5.16.9 Handling Stresses

In computing stresses due to handling, the static loads shall be increased by 50 percent as an allowance for impact and shock.

4.5.17 Cast-In-Place Concrete Piles

4.5.17.1 Materials

Cast-in-place concrete piles shall be, in general, cast in metal shells that shall remain permanently in place. However, other types of cast-in-place piles, plain or reinforced, cased or uncased, may be used if the soil conditions permit their use and if their design and method of placing are satisfactory.

4.5.17.2 Shape

Cast-in-place concrete piles may have a uniform cross-section or may be tapered over any portion.

4.5.17.3 Minimum Area

The minimum area at the butt of the pile shall be 100 inches and the minimum diameter at the tip of the pile shall be 8 inches. Above the butt or taper, the minimum size shall be as specified for precast piles.

4.5.17.4 General Reinforcement Requirements

Cast-in-place piles, carrying axial loads only where the possibility of lateral forces being applied to the piles is insignificant, need not be reinforced where the soil provides adequate lateral support. Those portions of cast-in-place concrete piles that are not supported laterally shall be designed as reinforced concrete columns in accordance with Articles 8.15.4 and 8.16.4, and the reinforcing steel shall extend 10 feet below the plane where the soil provides adequate lateral restraint. Where the shell is smooth pipe and more than 0.12 inch in thickness, it may be considered as load carrying in the absence of corrosion. Where the shell is corrugated and is at least 0.075 inch in thickness, it may be considered as providing confinement in the absence of corrosion.

4.5.17.5 Reinforcement into Superstructure

Sufficient reinforcement shall be provided at the junction of the pile with the superstructure to make a suitable connection. The embedment of the reinforcement into the cap shall be as specified for precast piles.

4.5.17.6 Shell Requirements

The shell shall be of sufficient thickness and strength so that it will hold its original form and show no harmful distortion after it and adjacent shells have been driven and the driving core, if any, has been withdrawn. The plans shall stipulate that alternative designs of the shell must be approved by the Engineer before any driving is done.

4.5.17.7 Splices

Piles may be spliced provided the splice develops the full strength of the pile. Splices should be detailed on the contract plans. Any alternative method of splicing providing equal results may be considered for approval.

4.5.17.8 Reinforcement Cover

The reinforcement shall be placed a clear distance of not less than 2 inches from the cased or uncased sides. When piles are in corrosive or marine environments, or when concrete is placed by the water or slurry displacement methods, the clear distance shall not be less than 3 inches for uncased piles and piles with shells not sufficiently corrosion resistant.

4.5.17.9 Spacing Limitations

- + The spacing limitation for reinforcement shall be
- + considered in the design as provided in Article 8.21.7.

4.5.18 Steel H-Piles

4.5.18.1 Metal Thickness

Steel piles shall have a minimum thickness of web of 0.400 inch. Splice plates shall not be less than 1/8 in. thick.

4.5.18.2 Splices

Piles shall be spliced to develop the net section of pile. The flanges and web shall be either spliced by butt welding or with plates that are welded, riveted, or bolted. Splices shall be detailed on the contract plans. Prefabricated splicers may be used if the splice can develop the net section of the pile in compression, tension, shear, and bending.

4.5.18.3 Caps

In general, caps are not required for steel piles embedded in concrete.

4.5.18.4 Lugs, Scabs, and Core-Stoppers

These devices may be used to increase the bearing capacity of the pile where necessary. They may consist of structural shapes—welded, riveted, or bolted—of plates welded between the flanges, or of timber or concrete blocks securely fastened.

4.5.18.5 Point Attachments

If pile penetration through cobbles, boulders, debris fill or obstructions is anticipated, pile tips shall be rein-

forced with structural shapes or with prefabricated cast steel points. Cast steel points shall meet the requirements of ASTM A27.

4.5.19 Unfilled Tubular Steel Piles

4.5.19.1 Metal Thickness

Piles shall have a minimum thickness not less than indicated in the following table:

Outside Diameter	Less than 14 inches	14 inches and over
Wall Thickness	0.25 inch	0.375 inch

4.5.19.2 Splices

Piles shall be spliced to develop the full section of the pile. The piles shall be spliced either by butt welding or by the use of welded sleeves. Splices shall be detailed on the contract plans.

4.5.19.3 Driving

Tubular steel piles may be driven either closed or open ended. Closure plates should not extend beyond the perimeter of the pile.

4.5.19.4 Column Action

Where the piles are to be used as part of a bent structure or where heavy scour is anticipated that would expose a portion of the pile, the pile will be investigated for column action. The provisions of Article 4.5.8 shall apply to unfilled tubular steel piles.

4.5.20 Prestressed Concrete Piles

4.5.20.1 Size and Shape

Prestressed concrete piles that are generally octagonal, square or circular shall be of approved size and shape. Air entrained concrete shall be used in piles that are subject to freezing and thawing or wetting and drying. Concrete in prestressed piles shall have a minimum compressive strength, f'_c of 5,000 psi at 28 days. Prestressed concrete piles may be solid or hollow. For hollow piles, precautionary measures should be taken to

prevent breakage due to internal water pressure during driving, ice pressure in trestle piles, and gas pressure due to decomposition of material used to form the void.

4.5.20.2 Main Reinforcement

Main reinforcement shall be spaced and stressed so as to provide a compressive stress on the pile after losses, f_{pe} , general not less than 700 psi to prevent cracking during handling and installation. Piles shall be designed to resist stresses developed during handling as well as under service load conditions. Bending stresses shall be investigated for all conditions of handling, taking into account the weight of the pile plus 50-percent allowance for impact, with tensile stresses limited to $5\sqrt{f'_c}$.

4.5.20.3 Vertical Reinforcement

The full length of vertical reinforcement shall be enclosed within spiral reinforcement. For piles up to 24 inches in diameter, spiral wire shall be No. 5 (U.S. Steel Wire Gage). Spiral reinforcement at the ends of these piles shall have a pitch of 3 inches for approximately 16 turns. In addition, the top 6 inches of pile shall have five turns of spiral winding at 1-inch pitch. For the remainder of the pile, the vertical steel shall be enclosed with spiral reinforcement with not more than 6-inch pitch. For piles having diameters greater than 24 inches, spiral wire shall be No. 4 (U.S. Steel Wire Gage). Spiral reinforcement at the end of these piles shall have a pitch of 2 inches for approximately 16 turns. In addition, the top 6 inches of pile shall have four turns of spiral winding at 1 $\frac{1}{2}$ inches. For the remainder of the pile, the vertical steel shall be enclosed with spiral reinforcement with not more than 4-inch pitch. The reinforcement shall be placed at a clear distance from the face of the prestressed pile of not less than 2 inches.

4.5.20.4 Hollow Cylinder Piles

- + Large diameter hollow cylinder piles shall be of approved size and shape. The wall thickness for cylinder
- + piles shall not be less than 5 inches.

4.5.20.5 Splices

When prestressed concrete piles are spliced, the splice shall be capable of developing the full section of the pile. Splices shall be detailed on the contract plans.

4.5.21 Timber Piles

4.5.21.1 Materials

Timber piles shall conform to the requirements of the Specifications for Wood Products, AASHTO M 168. Timber piles shall be treated or untreated as indicated on the contract plans. Preservative treatment shall conform to the requirements of Section 16, "Preservative Treatments for Lumber."

4.5.21.2 Limitations on Untreated Timber Pile Use

Untreated timber piles may be used for temporary construction, revetments, fenders, and similar work, and in permanent construction under the following conditions:

- For foundation piling when the cutoff is below permanent ground water level.
- For trestle construction when it is economical to do so, although treated piles are preferable.
- They shall not be used where they will, or may, be exposed to marine borers.
- They shall not be used where seismic design considerations are critical.

4.5.21.3 Limitations on Treated Timber Pile Use

Treated timber piles shall not be used where seismic design considerations are critical.

4.6 DRILLED SHAFTS

4.6.1 General

The provisions of this article shall apply to the design of axially and laterally loaded drilled shafts in soil or extending through soil to or into rock.

4.6.1.1 Application

Drilled shafts may be considered when spread footings cannot be founded on suitable soil or rock strata within a reasonable depth and when piles are not economically viable due to high loads or obstructions to driving. Drilled shafts may be used in lieu of spread footings as a

protection against scour. Drilled shafts may also be considered to resist high lateral or uplift loads when deformation tolerances are small.

4.6.1.2 Materials

Shafts shall be cast-in-place concrete and may include deformed bar steel reinforcement, structural steel sections, and/or permanent steel casing as required by design. In every case, materials shall be supplied in accordance with the provisions of this Standard.

4.6.1.3 Construction

Drilled shafts may be constructed using the dry, casing, or wet method of construction, or a combination of methods. In every case, hole excavation, concrete placement, and all other aspects of shaft construction shall be performed in conformance with the provisions of this Standard.

4.6.1.4 Embedment

Shaft embedment shall be determined based on vertical and lateral load capacities of both the shaft and subsurface materials.

4.6.1.5 Shaft Diameter

For rock-socketed shafts which require casing through the overburden soils, the socket diameter should be at least 6 inches less than the inside diameter of the casing to facilitate drill tool insertion and removal through the casing. For rock-socketed shafts not requiring casing through the overburden soils, the socket diameter can be equal to the shaft diameter through the soil.

4.6.1.6 Batter Shafts

The use of battered shafts to increase the lateral capacity of foundations is not recommended due to their difficulty of construction and high cost. Instead, consideration should first be given to increasing the shaft diameter to obtain the required lateral capacity.

4.6.1.7 Shafts Through Embankment Fill

Shafts extending through embankments shall extend a minimum of 10 feet into original ground unless bedrock or competent bearing strata occurs at a lesser penetration.

Fill used for embankment construction shall be random fill material having adequate capacity which shall not obstruct shaft construction to the required depth. Negative skin friction loads due to settlement and consolidation of embankment or underlying soils shall be evaluated for shafts in embankments. (See Article 4.6.5.2.5.)

4.6.2 Notations

The following notations shall apply for the design of drilled shaft foundations in soil and rock:

- a = Tip bearing factor to account for large diameter shaft tip (dim); (See Article 4.6.5.1.3)
- A = Area of shaft (ft²)
- A_t = Area of shaft tip (ft²)
- b = Tip bearing factor to account for large diameter shaft tip (dim); (See Article 4.6.5.1.3)
- B = Shaft diameter (ft); (See Article 4.6.3)
- B_b = Diameter of enlarged base (ft); (See Article 4.6.3)
- B₁ = Least width of shaft group (ft); (See Article 4.6.5.2.4.3)
- B_r = Diameter of rock socket (ft); (See Article 4.6.3)
- B_t = Tip diameter (ft); (See Article 4.6.5.1.3)
- C_m = Uniaxial compressive strength of rock mass (ksf); (See Article 4.6.5.3. 1)
- C_o = Uniaxial compressive strength of intact rock (ksf)
- D = Shaft length (ft); (See Article 4.6.3)
- D_r = Length of rock socket (ft); (See Article 4.6.3)
- E_c = Elastic modulus of concrete shaft or reinforced shaft (ksf)
- E_o = Elastic modulus of intact rock (ksf)
- E_m = Elastic modulus of rock mass (ksf)
- FS = Factor of safety (dim)
- f_{si} = Ultimate load transfer along shaft (ksf); (See Article 4.6.5.1.1 and 4.6.5.1.2)
- H = Distance from shaft tip to top of weak soil layer (ft); (See Article 4.6.5.2.4.3)
- i = Depth interval (dim); (See Articles 4.6.5.1.1 and 4.6.5.1.2)
- I_{ps} = Displacement influence factor for rock-socketed shafts loaded in compression (dim); (See Article 4.6.5.5.2)
- I_{pu} = Displacement influence factor for rock-socketed shafts loaded in uplift (dim); (See Article 4.6.5.5.2)
- N = Standard penetration resistance (blows/ft)
- N' = Standard penetration test blow count corrected for effects of overburden (blows/ft)

N_c	= Bearing capacity factor (dim); (See Article 4.6.5.1.3)		
N_i	= Number of depth intervals into which shaft is divided for determination of side resistance (dim); (See Articles 4.6.5.1.1 and 4.6.5.1.2)	β_i	= Load transfer factor in the i th interval (dim); (See Article 4.6.5.1.2)
P	= Lateral load on shaft (k)	γ'_i	= Effective soil unit weight in i th interval (kcf); (See Article 4.6.5.1.2)
Q	= Total axial compression load applied to shaft butt (k)	Δz_i	= i th increment of shaft length (ft)
q_E	= Ultimate unit tip capacity for an equivalent shaft for a group of shafts supported in strong layer overlying weaker layer (ksf); (See Article 4.6.5.2.4.3)	ζ	= Factor to account for reduced individual capacity of closely spaced shafts in group (dim); (See Article 4.6.5.2.4.1)
q_{Lo}	= Ultimate unit tip capacity of an equivalent shaft bearing in weaker underlying soil layer (ksf); (See Article 4.6.5.2.4.3)	ρ_e	= Elastic shortening of shaft (ft); (See Articles 4.6.5.5.1.1 and 4.6.5.5.1.2)
Q_u	= Total axial uplift load applied to shaft butt (k)	ρ_s	= Total settlement displacement at butt for shaft with rock socket (ft); (See Article 4.6.5.5.2)
q_{UP}	= Ultimate unit tip capacity of an equivalent shaft bearing in stronger upper soil layer (ksf); (See Article 4.6.5.2.4.3)	ρ_u	= Total uplift displacement at butt for shaft with rock socket (ft); (See Equation 4.6.5.5.2)
Q_S	= Ultimate side resistance in soil (k); (See Articles 4.6.5.1.1 and 4.6.5.1.2)	π	= 3.1415 (dim)
q_{SR}	= Ultimate unit shear resistance along shaft/rock interface (psi); (See Article 4.6.5.3.1)	ν	= Poisson's ratio (dim)
Q_{SR}	= Ultimate side resistance of rock socket (k); (See Article 4.6.5.3.1)	σ_c	= Unconfined compressive strength of rock mass or concrete, whichever is weaker (psi); (See Article 4.6.5.3.1)
q_T	= Ultimate unit tip resistance for shafts (ksf); (See Articles 4.6.5.1.3 and 4.6.5.1.4)	σ_{vi}	= Effective vertical stress at midpoint of i th depth interval (ksf); (See Article 4.6.5.1.2)
q_{TR}	= Ultimate unit tip resistance for shafts reduced for size effects (ksf); (See Equations 4.6.5.1.3-3 and 4.6.5.1.4-2)		
Q_T	= Ultimate tip resistance in soil (k); (See Articles 4.6.5.1.3 and 4.6.5.1.4)		
Q_{TR}	= Ultimate tip resistance of rock socket (k); (See Article 4.6.5.3.2)		
Q_{ult}	= Ultimate axial load capacity (k); (See Article 4.6.5.1)		
RQD	= Rock Quality Designation (dim)		
s_{ui}	= Incremental undrained shear strength as a function over i th depth interval (ksf); (See Article 4.6.5.1.1)		
s_{ut}	= Undrained shear strength within 2B below shaft tip (ksf); (See Article 4.6.5.1.3)		
W	= Weight of shaft (k)		
z_i	= Depth to midpoint of i th interval (ft); (See Article 4.6.5.1.2)		
α	= Adhesion factor (dim)		
α_i	= Adhesion factor as a function over i th depth interval (dim); (See Article 4.6.5.1.1)		
α_E	= Reduction factor to estimate rock mass modulus and uniaxial strength from the modulus and uniaxial strength of intact rock (dim); (See Article 4.6.5.3.1)		

The notations for dimension units include the following: dim = Dimensionless; deg = degree; ft = foot; k = kip; k/ft = kip/ft; ksf = kip/ft² and kcf = kip/ft³. The dimensional units provided with each notation are presented for illustration only to demonstrate a dimensionally correct combination of units for the shaft capacity and settlement procedures presented below. If other units are used, the dimensional correctness of the equations should be confirmed.

4.6.3 Design Terminology

Refer to Figure 4.6.3A for terminology used in design of drilled shafts.

4.6.4 Selection of Soil and Rock Properties

Soil and rock properties defining the strength and compressibility characteristics of the foundation materials are required for drilled shaft design.

4.6.4.1 Presumptive Values

Presumptive values for allowable bearing pressures on soil and rock may be used only for guidance, preliminary design or design of temporary structures. The use of presumptive values shall be based on the results of

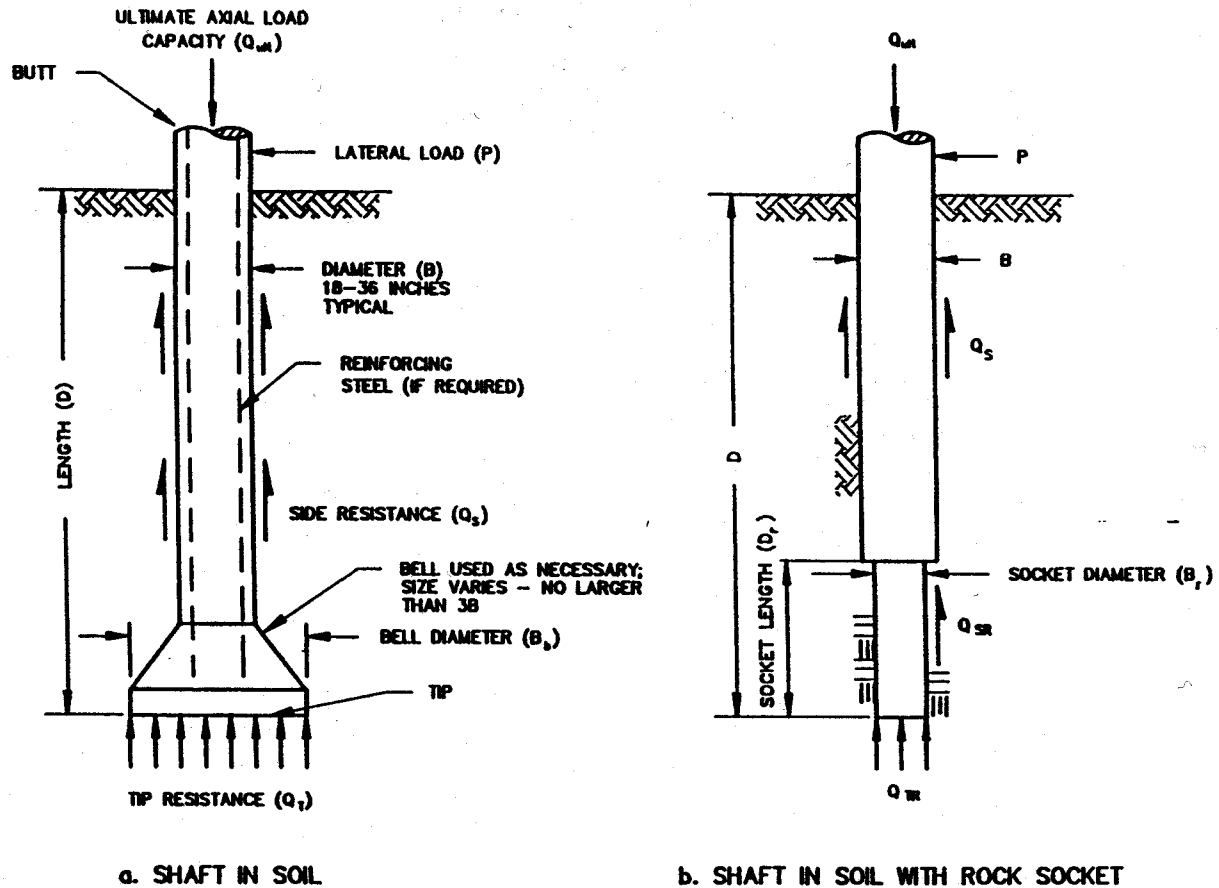

FIGURE 4.6.3A Design Terminology for Drilled Shaft Foundations

subsurface exploration to identify soil and rock conditions. All values used for design shall be confirmed by field and/or laboratory testing.

4.6.4.2 Measured Values

Foundation stability and settlement analyses for final design shall be performed using soil and rock properties based on the results of field and/or laboratory testing.

4.6.5 Geotechnical Design

- + Drilled shafts shall be designed to support the design
- + loads with adequate bearing and structural capacity, and
- + with tolerable settlements in conformance with Articles
- + 4.6.5 and 4.6.6.

Shaft design shall be based on working stress prin-

ciples using maximum unfactored loads derived from calculations of dead and live loads from superstructures, substructures, earth (i.e., sloping ground), wind and traffic. Allowable axial and lateral loads may be determined by separate methods of analysis.

The design methods presented herein for determining axial load capacity assume drilled shafts of uniform cross-section, with vertical alignment, concentric axial loading and a relatively horizontal ground surface. The effects of an enlarged base, group action, and sloping ground are treated separately.

4.6.5.1 Axial Capacity in Soil

The ultimate axial capacity (Q_{ult}) of drilled shafts shall be determined in accordance with the following for

compression and uplift loading, respectively:

$$Q_{ult} = Q_S + Q_T - W \quad (4.6.5.1-1)$$

$$Q_{ult} \leq 0.7 Q_S + W \quad (4.6.5.1-2)$$

The allowable or working axial load shall be determined as:

$$Q_{all} = Q_{ult}/FS \quad (4.6.5.1-3)$$

Shafts in cohesive soils may be designed by total and effective stress methods of analysis, for undrained and drained loading conditions, respectively. Shafts in cohesionless soils shall be designed by effective stress methods of analysis for drained loading conditions.

4.6.5.1.1 Side Resistance in Cohesive Soil

For shafts in cohesive soil loaded under undrained loading conditions, the ultimate side resistance may be estimated using the following:

$$Q_S = \pi B \sum_{i=1}^N \alpha_i s_{ui} \Delta z_i \quad (4.6.5.1.1-1)$$

The ultimate unit load transfer in side resistance at any depth f_{si} is equal to the product of α_i and s_{ui} . Refer to Table 4.6.5. 1. 1 A for guidance regarding selection of α_i and limiting values of f_{si} for shafts excavated dry in open or cased holes. Environmental, long-term loading or construction factors may dictate that a depth greater than 5 feet should be ignored in estimating Q_S . Refer to Figure

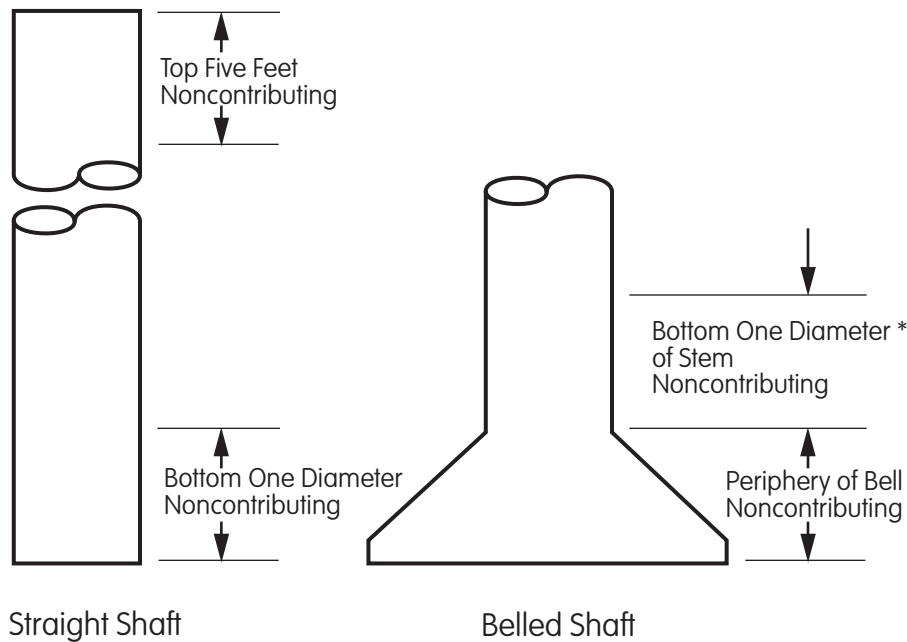

* Two Diameters in Stiff Fissured Clay.

FIGURE 4.6.5.1.1A Identification of Portions of Drilled Shafts Neglected for Estimation of Drilled Shaft Side Resistance in Cohesive Soil
Reese and O'Neill (1988)

4.6.5.1.1A for identification of portions of drilled shaft not considered in contributing to the computed value of Q_S . For shafts in cohesive soil under drained loading conditions, Q_S may be determined using the procedure in Article 4.6.5.1.2.

Where time-dependent changes in soil shear strength may occur (e.g., swelling of expansive clay or downdrag from a consolidating clay), effective stress methods (Article 4.6.5.1.2) should be used to compute Q_S in the zone where such changes may occur.

4.6.5.1.2 Side Resistance in Cohesionless Soil

For shafts in cohesionless soil or for effective stress analysis of shafts in cohesive soils under drained loading conditions, the ultimate side resistance of axially loaded drilled shafts may be estimated using the following:

$$\pi B \sum_{i=1}^N \gamma'_i z_i \beta_i \Delta z_i \quad (4.6.5.1.2-1)$$

The value of β_i may be determined using the following:

$$\beta_i = 1.5 - 0.5 - 0.135 \sqrt{z_i}; 1.2 > \beta_i > 0.25 \quad (4.6.5.1.2-2)$$

The value of γ'_i should be determined from measurements from undisturbed samples along the length of the shaft or from empirical correlations with SPT or other in-situ test methods. The ultimate unit load transfer in side resistance at any depth, f_{si} is equal to the product of β_i and σ'_{vi} . The limiting value of f_{si} for shafts in cohesionless soil is 4 ksf.

TABLE 4.6.5.1.1A Recommended Values of α and f_{si} for Estimation of Drilled Shaft Side Resistance in Cohesive Soil Reese and O'Neill (1988)

Location Along Drilled Shaft	Value of α	Limiting Value of Load Transfer, f_{si} (ksf)
From ground surface to depth along drilled shaft of 5 ft*	0	–
Bottom 1 diameter of the drilled shaft or 1 stem diameter above the top of the bell (if skin friction is being used)	0	–
All other points along the sides of the drilled shaft	0.55	5.5

*The depth of 5 ft may need adjustment if the drilled shaft is installed in expansive clay or if there is substantial groundline deflection from lateral loading.

4.6.5.1.3 Tip Resistance in Cohesive Soil

For axially loaded shafts in cohesive soil subjected to undrained loading conditions, the ultimate tip resistance of drilled shafts may be estimated using the following:

$$Q_T = q_T A_t = N_c S_{ut} A_t \quad (4.6.5.1.3-1)$$

Values of the bearing capacity factor N_c may be determined using the following:

$$N_c = 6.0[1 + 0.2(D/B_t)]; N_c \leq 9 \quad (4.6.5.1.3-2)$$

The limiting value of unit end bearing ($q_T = N_c S_{ut}$) is 80 ksf.

The value of S_{ut} should be determined from the results of in-situ and/or laboratory testing of undisturbed samples obtained within a depth of $2B$ below the tip of the shaft. If the soil within $2B$ of the tip is of soft consistency, the value of N_c should be reduced by one-third.

If $B_t > 6.25$ feet (75 inches) and shaft settlements will not be evaluated, the value of q_T should be reduced to q_{TR} as follows:

$$q_{TR} = F_r q_T = (2.5/[aB_t/12 + 2.5b])q_T \quad (4.6.5.1.3-3)$$

$$a = 0.0071 + 0.0021(D/B_t); a \leq 0.015 \quad (4.6.5.1.3-4)$$

$$b = 0.45(s_{ult})^{0.5}; 0.5 \leq b \leq 1.5(4.6.5.1.3-5)$$

The limiting value of q_{TR} is 80 ksf.

For shafts in cohesive soil under drained loading conditions, Q_T may be estimated using the procedure described in Article 4.6.5.1.4.

4.6.5.1.4 Tip Resistance in Cohesionless Soil

For axially loaded drilled shafts in cohesionless soils or for effective stress analysis of axially loaded drilled shafts in cohesive soil, the ultimate tip resistance may be estimated using the following:

$$Q_T = q_T A_t \quad (4.6.5.1.4-1)$$

The value of q_T may be determined from the results of standard penetration testing using uncorrected blow count readings within a depth of 2B below the tip of the shaft. Refer to Table 4.6.5.1.4A for recommended values of q_T .

If $B_t > 4.2$ feet (50 inches) and shaft settlements will not be evaluated, the value of q_T should be reduced to q_{TR} as follows:

$$q_{TR} = (50/12B_t)q_T \quad (4.6.5.1.4-2)$$

4.6.5.2 Factors Affecting Axial Capacity in Soil

4.6.5.2.1 Soil Layering and Variable Soil Strength with Depth

The design of shafts in layered soil deposits or soil deposits having variable strength with depth requires evaluation of soil parameters characteristic of the respective layers or depths. Q_S in such soil deposits may be estimated by dividing the shaft into layers according to soil type and properties, determining Q_S for each layer, and summing values for each layer to obtain the total Q_S . If the soil below the shaft tip is of variable consistency, Q_T may be estimated using the predominant soil strata within 2B below the shaft tip.

For shafts extending through soft compressible layers to tip bearing on firm soil or rock, consideration shall be given to the effects of negative skin friction (Article 4.6.5.2.5) due to the consolidation settlement of soils surrounding the shaft. Where the shaft tip would bear on

a thin firm soil layer underlain by a softer soil unit, the shaft shall be extended through the softer soil unit to eliminate the potential for a punching shear failure into the softer deposit.

TABLE 4.6.5.1.4A Recommended Values of q_T^* for Estimation of Drilled Shaft Tip Resistance in Cohesionless Soil after Reese and O'Neill (1988)

Standard Penetration Resistance N (Blows/Foot) (uncorrected)	Value of q_T (ksf)
0 to 75	1.20 N
Above 75	90

*Ultimate value or value at settlement of 5 percent of base diameter.

4.6.5.2.2 Ground Water

The highest anticipated water level shall be used for design.

4.6.5.2.3 Enlarged Bases

An enlarged base (bell or underream may be used at the shaft tip in stiff cohesive soil to increase the tip bearing area and reduce the unit end bearing pressure, or to provide additional resistance to uplift loads.

The tip capacity of an enlarged base shall be determined assuming that the entire base area is effective in transferring load. Allowance of full effectiveness of the enlarged base shall be permitted only when cleaning of the bottom of the drilled hole is specified and can be acceptably completed before concrete placement.

4.6.5.2.4 Group Action

Evaluation of group shaft capacity assumes the effects of negative skin friction (if any) are negligible.

4.6.5.2.4.1 Cohesive Soil

Evaluation of group capacity of shafts in cohesive soil shall consider the presence and contact of a cap with the ground surface and the spacing between adjacent shafts.

For a shaft group with a cap in firm contact with the ground, Q_{ult} may be computed as the lesser of (1) the sum

of the individual capacities of each shaft in the group or (2) the capacity of an equivalent pier defined in the perimeter area of the group. For the equivalent pier, the shear strength of soil shall not be reduced by any factor (e.g., α_1 to determine the Q_s component of Q_{ult} , the total base area of the equivalent pier shall be used to determine the Q_T component of Q_{ult} , and the additional capacity of the cap shall be ignored.

+ If the cap is not in firm contact with the ground, or if
 + the soil at the surface is loose or soft, the individual
 + capacity of each shaft should be reduced to ζ times Q_T for
 + an isolated shaft, where $\zeta = 1.0$ for a center-to-center
 + (CTC) spacing of $6B$ or greater, for a CTC of less than $6B$
 + the Division of Structural Foundations should be con-
 + sulted to determine the value of ζ . The group capacity
 + may then be computed as the lesser of (1) the sum of the
 + modified individual capacities of each shaft in the group,
 + or (2) the capacity of an equivalent pier as described
 + above.

4.6.5.2.4.2 Cohesionless Soil

+ Evaluation of group capacity of shafts in cohesionless
 + soil shall consider the spacing between adjacent shafts.
 + Regardless of cap contact with the ground, the individual
 + capacity of each shaft should be reduced to ζ times Q_T for
 + an isolated shaft, where $\zeta = 1.0$ for a center-to-center
 + (CTC) spacing of $8B$ or greater, for a CTC of less than $8B$
 + the Division of Structural Foundations should be con-
 + sulted to determine the value of ζ . The group capacity
 + may be computed as the lesser of (1) the sum of the
 + modified individual capacities of each shaft in the group
 + or (2) the capacity of an equivalent pier circumscribing
 + the group, including resistance over the entire perimeter
 + and base areas.

4.6.5.2.4.3 Group in Strong Soil Overlying Weaker Soil

If a group of shafts is embedded in a strong soil deposit which overlies a weaker deposit (cohesionless and cohesive soil), consideration shall be given to the potential for a punching failure of the tip into the weaker soil strata. For this case, the unit tip capacity of the equivalent shaft (q_E) may be determined using the following:

$$q_E = q_{LO} + (H/10B)(q_{up}) \leq q_{up} \quad (4.6.5.2.4.3-1)$$

If the underlying soil unit is a weaker cohesive soil strata, careful consideration shall be given to the potential for large settlements in the weaker layer.

4.6.5.2.5 Vertical Ground Movement

The potential for external loading on a shaft by vertical ground movement (i.e., negative skin friction/downdrag due to settlement of compressible soil or uplift due to heave of expansive soil) shall be considered as a part of design. For design purposes, it shall be assumed that the full magnitude of maximum potential vertical ground movement occurs.

Evaluation of negative skin friction shall include a load-transfer method of analysis to determine the neutral point (i.e., point of zero relative displacement) and load distribution along shaft (e.g., Reese and O'Neill, 1988). Due to the possible time dependence associated with vertical ground movement, the analysis shall consider the effect of time on load transfer between the ground and shaft and the analysis shall be performed for the time period relating to the maximum axial load transfer to the shaft.

Shafts designed for and constructed in expansive soil shall extend to a sufficient depth into moisture-stable soils to provide adequate anchorage to resist uplift movement. In addition, sufficient clearance shall be provided between the ground surface and underside of caps or beams connecting shafts to preclude the application of uplift loads at the shaft/cap connection from swelling ground conditions. Uplift capacity shall rely only on side resistance in conformance with Article 4.6.5.1. If the shaft has an enlarged base, Q_s shall be determined in conformance with Article 4.6.5.2.3.

4.6.5.2.6 Method of Construction

The load capacity and deformation behavior of drilled shafts can be greatly affected by the quality and method(s) of construction. The effects of construction methods are incorporated in design by application of a factor of safety consistent with the expected construction method(s) and level of field quality control measures (Article 4.6.5.4).

Where the spacing between shafts in a group is restricted, consideration shall be given to the sequence of construction to minimize the effect of adjacent shaft construction operations on recently constructed shafts.

4.6.5.3 Axial Capacity in Rock

Drilled shafts are socketed into rock to limit axial displacements, increase load capacity and/or provide fixity for resistance to lateral loading. In determining the axial capacity of drilled shafts with rock sockets, the side resistance from overlying soil deposits may be ignored.

Typically, axial compression load is carried solely by the side resistance on a shaft socketed into rock until a total shaft settlement (ρ_s) on the order of 0.4 inches occurs. At this displacement, the ultimate side resistance, Q_{SR} is mobilized and slip occurs between the concrete and rock. As a result of this slip, any additional load is transferred to the tip.

The design procedures assume the socket is constructed in reasonably sound rock that is little affected by construction (i.e., does not rapidly degrade upon excavation and/or exposure to air or water) and which is cleaned prior to concrete placement (i.e., free of soil and other debris). If the rock is degradable, consideration of special construction procedures, larger socket dimensions, or reduced socket capacities should be considered.

4.6.5.3.1 Side Resistance

The ultimate side resistance (Q_{SR}) for shafts socketed into rock may be determined using the following:

$$Q_{SR} = \pi B_r D_r (0.144 q_{SR}) \quad (4.6.5.3.1-1)$$

Refer to Figure 4.6.5.3.1 A for values of q_{SR} . For uplift loading Q_{ult} of a rock socket shall be limited to $0.7Q_{SR}$.

The design of rock sockets shall be based on the unconfined compressive strength of the rock mass (C_m) or concrete, whichever is weaker (σ_c). C_m may be estimated using the following relationship:

$$C_m = \alpha_E C_o \quad (4.6.5.3.1-2)$$

Refer to Article 4.4.8.2.2 for the procedure to determine α_E as a function of RQD.

4.6.5.3.2 Tip Resistance

Evaluation of ultimate tip resistance (Q_{TR}) for rock-socketed drilled shafts shall consider the influence of rock discontinuities. Q_{TR} for rock-socketed drilled shafts may be determined using the following:

$$Q_{TR} = N_{ms} C_o A_t \quad (4.6.5.3.2-1)$$

Preferably, values of C_o should be determined from the results of laboratory testing of rock cores obtained within $2B$ of the base of the footing. Where rock strata within this interval are variable in strength, the rock with the lowest

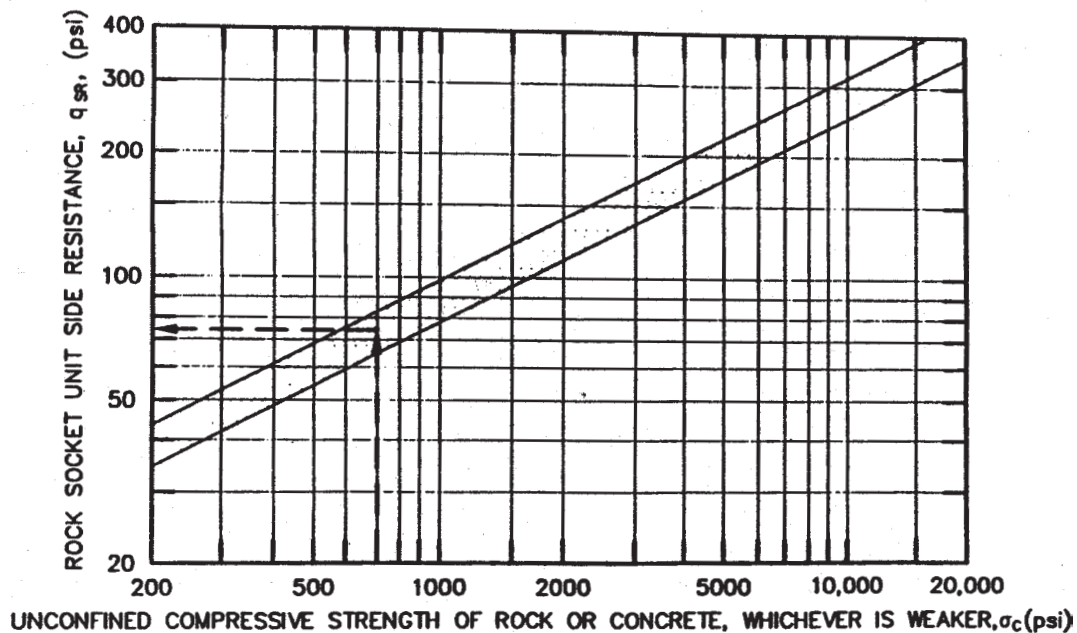

FIGURE 4.6.5.3.1A Procedure for Estimating Average Unit Shear for Smooth Wall Rock-Socketed Shafts Horvath, et al. (1983)

capacity should be used to determine Q_{TR} . Alternatively, Table 4.4.8.1.2B may be used as a guide to estimate C_o . For rocks defined by very poor quality, the value of Q_{TR} cannot be less than the value of Q_T for an equivalent soil mass.

4.6.5.3.3 Factors Affecting Axial Capacity in Rock

4.6.5.3.3.1 Rock Stratification

Rock stratification shall be considered in the design of rock sockets as follows:

- Sockets embedded in alternating layers of weak and strong rock shall be designed using the strength of the weaker rock.
- The side resistance provided by soft or weathered rock should be neglected in determining the required socket length where a socket extends into more competent underlying rock. Rock is defined as soft when the uniaxial compressive strength of the weaker rock is less than 20 percent of that of the stronger rock, or weathered when the RQD is less than 20 percent.
- Where the tip of a shaft would bear on thin rigid rock strata underlain by a weaker unit, the shaft shall be extended into or through the weaker unit (depending on load capacity or deformation requirements) to eliminate the potential for failure due to flexural tension or punching failure of the thin rigid stratum.
- Shafts designed to bear on strata in which the rock surface is inclined should extend to a sufficient depth to ensure that the shaft tip is fully bearing on the rock.
- Shafts designed to bear on rock strata in which bedding planes are not perpendicular to the shaft axis shall extend a minimum depth of 2B into the dipping strata to minimize the potential for shear failure along natural bedding planes and other slippage surfaces associated with stratification.

4.6.5.3.3.2 Rock Mass Discontinuities

The strength and compressibility of rock will be affected by the presence of discontinuities (joints and fractures). The influence of discontinuities on shaft behavior will be dependent on their attitude, frequency and condition, and shall be evaluated on a case-by-case basis as necessary.

4.6.5.3.3.3 Method of Construction

The effect of the method of construction on the engineering properties of the rock and the contact between the rock and shaft shall be considered as a part of the design process.

4.6.5.4 Factors of Safety

Drilled shafts in soil or socketed in rock shall be designed for a minimum factor of safety of 2.0 against bearing capacity failure (end bearing, side resistance or combined). The minimum recommended factors of safety are based on an assumed normal level of field quality control during shaft construction. If a normal level of field quality control cannot be assured, higher minimum factors of safety shall be used.

4.6.5.5 Deformation of Axially Loaded Shafts

The settlement of axially loaded shafts at working or allowable loads shall be estimated using elastic or load transfer analysis methods. For most cases, elastic analysis will be applicable for design provided the stress levels in the shaft are moderate relative to Q_{ult} . Where stress levels are high, consideration should be given to methods of load transfer analysis.

4.6.5.5.1 Shafts in Soil

Settlements should be estimated for the design or working load.

4.6.5.5.1.1 Cohesive Soil

The short-term settlement of shafts in cohesive soil may be estimated using Figures 4.6.5.5.1.1A and 4.6.5.5.1.1B. The curves presented indicate the proportions of the ultimate side resistance (Q_s) and ultimate tip resistance (Q_t) mobilized at various magnitudes of settlement. The total axial load on the shaft (Q) is equal to the sum of the mobilized side resistance (Q_s) and mobilized tip resistance (Q_t).

The settlement in Figure 4.6.5.5.1.1A incorporates the effects of elastic shortening of the shaft provided the shaft is of typical length (i.e., $D < 100$ ft). For longer shafts, the effects of elastic shortening may be estimated using the following:

$$\rho_e = PD/AE_c \quad (4.6.5.5.1.1-1)$$

For a shaft with an enlarged base in cohesive soil, the diameter of the shaft at the base (B_b) should be used in Figure 4.6.5.5.1.1B to estimate shaft settlement at the tip.

Refer to Article 4.4.7.2.3 for procedures to estimate the consolidation settlement component for shafts extending into cohesive soil deposits.

4.6.5.5.1.2 Cohesionless Soil

The short-term settlement of shafts in cohesionless soil may be estimated using Figures 4.6.5.5.1.2A and 4.6.5.5.1.2B. The curves presented indicate the proportions of the ultimate side resistance (Q_s) and ultimate tip resistance (Q_t) mobilized at various magnitudes of settlement. The total axial load on the shaft (Q) is equal to the sum of the mobilized side resistance (Q_s) and mobilized tip resistance (Q_t). Elastic shortening of the shaft shall be estimated using the following relationship:

$$\rho_e = PD/AE_c \quad (4.6.5.5.1.2-1)$$

4.6.5.5.1.3 Mixed Soil Profile

The short-term settlement of shafts in a mixed soil profile may be estimated by summing the proportional settlement components from layers of cohesive and cohesionless soil comprising the subsurface profile.

4.6.5.5.2 Shafts Socketed into Rock

In estimating the displacement of rock-socketed drilled shafts, the resistance to deformation provided by overlying soil deposits may be ignored. Otherwise, the load transfer to soil as a function of displacement may be estimated in accordance with Article 4.6.5.5.1.

The butt settlement (ρ_s) of drilled shafts fully socketed into rock may be determined using the following which is modified to include elastic shortening of the shaft:

$$\rho_e = Q \left[\left(I_{ps} / B_r E_m \right) + \left(D_r / AE_c \right) \right] \quad (4.6.5.5.2-1)$$

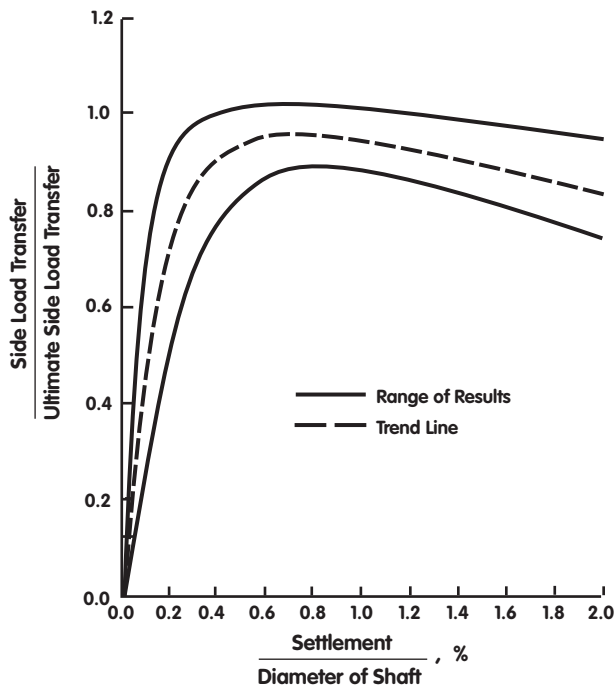

FIGURE 4.6.5.5.1.1A Load Transfer in Side Resistance Versus Settlement Drilled Shafts in Cohesive Soil After Reese and O'Neill (1988)

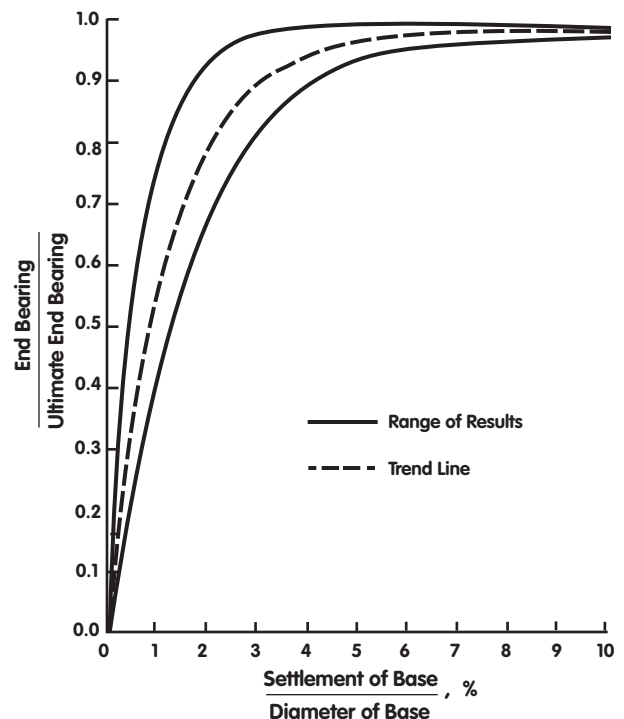

FIGURE 4.6.5.5.1.1B Load Transfer in Tip Bearing Settlement Drilled Shafts in Cohesive Soil After Reese and O'Neill (1988)

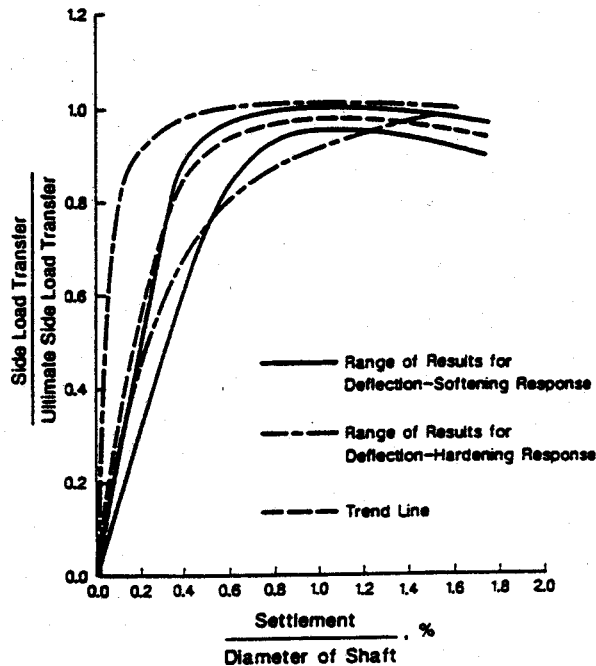

FIGURE 4.6.5.5.1.2A Load Transfer in Side Resistance Versus Settlement Drilled Shafts in Cohesionless Soil After Reese and O'Neill (1988)

Refer to Figure 4.6.5.5.2A to determine I_{ps} .

The uplift displacement (ρ_u) at the butt of drilled shafts fully socketed into rock may be determined using the following which is modified to include elastic shortening of the shaft:

$$\rho_u = Q_u \left[\left(I_{pu} / B_r E_m \right) + \left(D_r / AE_c \right) \right] \quad (4.6.5.5.2-2)$$

Refer to Figure 4.6.5.5.2B to determine I_{pu} .

The rock mass modulus (E_m) should be determined based on the results of in-situ testing (e.g., pressuremeter) or estimated from the results of laboratory tests in which E_m is the modulus of intact rock specimens, and (E_o) is estimated in accordance with Article 4.4.8.2.2.

For preliminary design or when site-specific test data cannot be obtained, guidelines for estimating values of E_o , such as presented in Table 4.4.8.2.2B or Figure 4.4.8.2.2A, may be used. For preliminary analyses or for final design when in-situ test results are not available, a value of $\alpha_E = 0.15$ should be used to estimate E_m .

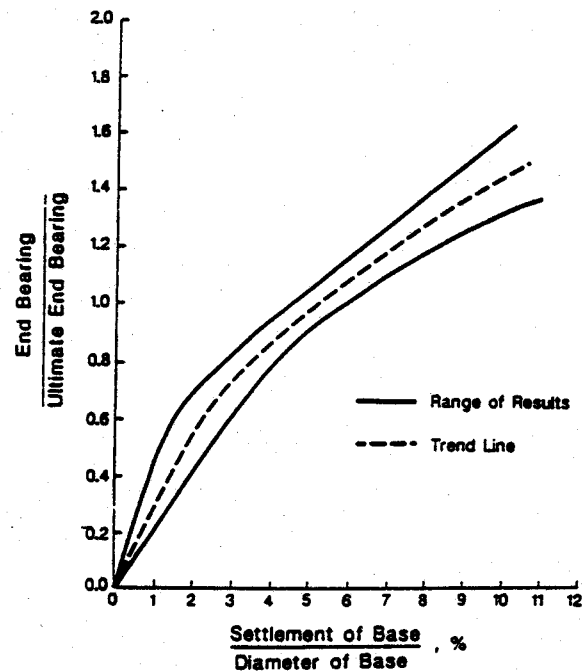

FIGURE 4.6.5.5.1.2B Load Transfer in Tip Bearing Versus Settlement Drilled Shafts in Cohesionless Soil After Reese and O'Neill (1988)

4.6.5.5.3 Tolerable Movement

Tolerable axial displacement criteria for drilled shaft foundations shall be developed by the structural designer consistent with the function and type of structure, fixity of bearings, anticipated service life, and consequences of unacceptable displacements on the structure performance. Drilled shaft displacement analyses shall be based on the results of in-situ and/or laboratory testing to characterize the load-deformation behavior of the foundation materials.

4.6.5.6 Lateral Loading

The design of laterally loaded drilled shafts shall account for the effects of soil/rock-structure interaction between the shaft and ground (e.g., Reese, 1984; Borden and Gabr, 1987). Methods of analysis evaluating the ultimate capacity or deflection of laterally loaded shafts (e.g., Broms, 1964a, b; Singh, et al., 1971) may be used for preliminary design only as a means to determine approximate shaft dimensions.

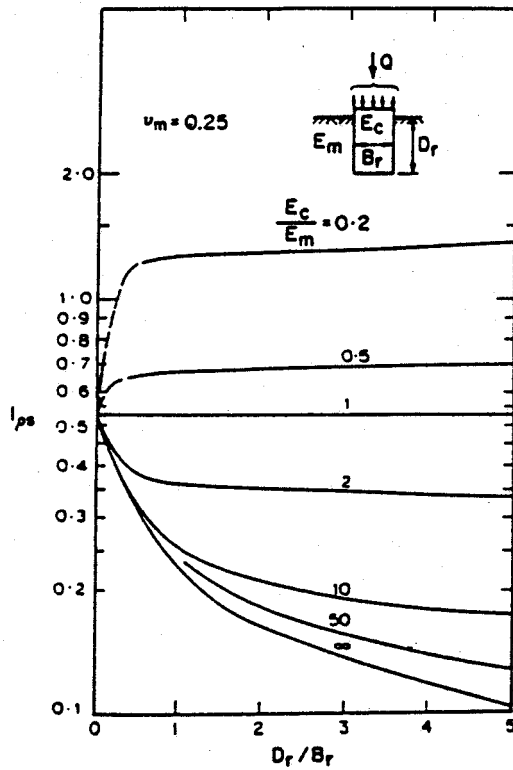

FIGURE 4.6.5.5.2A Influence Coefficient for Elastic Settlement of Rock-Socketed Drilled Shafts Modified after Pells and Turner (1979)

4.6.5.6.1 Factors Affecting Laterally Loaded Shafts

4.6.5.6.1.1 Soil Layering

The design of laterally loaded drilled shafts in layered soils shall be based on evaluation of the soil parameters characteristic of the respective layers.

4.6.5.6.1.2 Ground Water

The highest anticipated water level shall be used for design.

4.6.5.6.1.3 Scour

The potential for loss of lateral capacity due to scour shall be considered in the design. Refer to Article 1.3.2 and FHWA (1988) for general guidance regarding hydraulic studies and design. If heavy scour is expected, consideration shall be given to designing the portion of

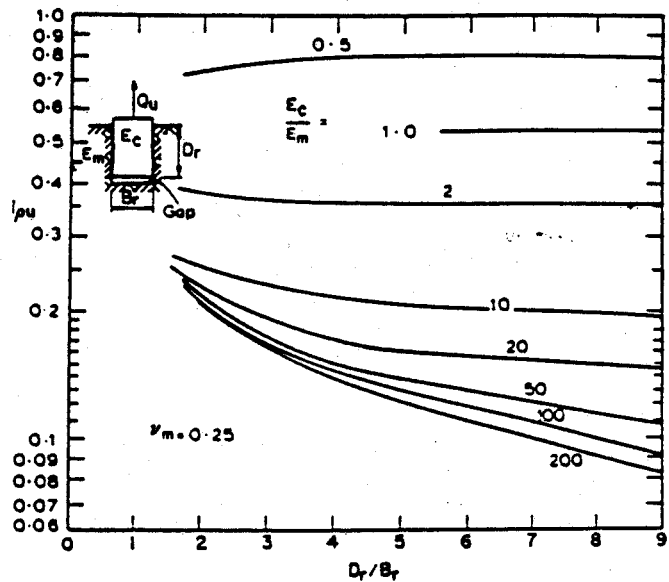

FIGURE 4.6.5.5.2B Influence Coefficient for Elastic Uplift Displacement of Rock-Socketed Drilled Shafts Modified after Pells and Turner (1979)

the shaft that would be exposed as a column. In all cases, the shaft length shall be determined such that the design structural load can be safely supported entirely below the probable scour depth.

4.6.5.6.1.4 Group Action

There is no reliable rational method for evaluating the group action for closely spaced, laterally loaded shafts. Therefore, as a general guide, drilled shafts in a group may be considered to act individually when the center-to-center (CTC) spacing, is greater than $2.5B$ in the direction normal to loading, and $CTC > 8B$ in the direction parallel to loading. For shaft layouts not conforming to these criteria, the effects of shaft interaction shall be considered in the design.

4.6.5.6.1.5 Cyclic Loading

The effects of traffic, wind, and other nonseismic cyclic loading on the load-deformation behavior of laterally loaded drilled shafts shall be considered during design. Analysis of drilled shafts subjected to cyclic loading may be considered in the COM624 analysis (Reese, 1984).

4.6.5.6.1.6 *Combined Axial and Lateral Loading*

The effects of lateral loading in combination with axial loading shall be considered in the design. Analysis of drilled shafts subjected to combined loading may be considered in the COM624 analysis (Reese, 1984).

4.6.5.6.1.7 *Sloping Ground*

For drilled shafts which extend through or below sloping ground, the potential for additional lateral loading shall be considered in the design. The general method of analysis developed by Borden and Gabr (1987) may be used for the analysis of shafts in stable slopes. For shafts in marginally stable slopes, additional consideration should be given for low factors of safety against slope failure or slopes showing ground creep, or when shafts extend through fills overlying soft foundation soils and bear into more competent underlying soil or rock formations. For unstable ground, detailed explorations, testing and analysis are required to evaluate potential additional lateral loads due to slope movements.

4.6.5.6.2 *Tolerable Lateral Movements*

Tolerable lateral displacement criteria for drilled shaft foundations shall be developed by the structural designer consistent with the function and type of structure, fixity of bearings, anticipated service life, and consequences of unacceptable displacements on the structure performance. Drilled shaft lateral displacement analysis shall be based on the results of in-situ and/or laboratory testing to characterize the load-deformation behavior of the foundation materials.

4.6.5.7 *Deleted*

4.6.6 **Structural Design and General Shaft Dimensions**

4.6.6.1 **General**

Drilled shafts shall be designed to insure that the shaft will not collapse or suffer loss of serviceability due to excessive stress and/or deformation. Shafts shall be designed to resist failure following applicable procedures presented in Section 8.

The diameter of shafts with rock sockets should be sized a minimum of 6 inches larger than the diameter of

the socket. The diameter of columns supported by shafts shall be less than or equal to B.

4.6.6.2 **Reinforcement**

Where the potential for lateral loading is insignificant, drilled shafts need to be reinforced for axial loads only. Those portions of drilled shafts that are not supported laterally shall be designed as reinforced concrete columns in accordance with Articles 8.15.4 and 8.16.4, and the reinforcing steel shall extend a minimum of 10 feet below the plane where the soil provides adequate lateral restraint.

Where permanent steel casing is used and the shell is smooth pipe and more than 0.12 inch in thickness, it may be considered as load carrying in the absence of corrosion.

The design of longitudinal and spiral reinforcement shall be in conformance with the requirements of Articles 8.18.1 and 8.18.2.2, respectively. Development of deformed reinforcement shall be in conformance with the requirements of Articles 8.24, 8.26, and 8.27.

4.6.6.2.1 *Spacing Limitation*

The spacing limitation for reinforcement shall be considered in the design as provided in Article 8.21.7

4.6.6.2.2 *Splices*

Splices shall develop the full capacity of the bar in tension and compression. The location of splices shall be staggered around the perimeter of the reinforcing cage so as not to occur at the same horizontal plane. Splices may be developed by lapping, welding, and special approved connectors. Splices shall be in conformance with the requirements of Article 8.32.

4.6.6.2.3 *Transverse Reinforcement*

Transverse reinforcement shall be designed to resist stresses caused by fresh concrete flowing from inside the cage to the side of the excavated hole. Transverse reinforcement may be constructed of hoops or spiral steel.

4.6.6.2.4 *Handling Stresses*

Reinforcement cages shall be designed to resist handling and placement stresses.

4.6.6.2.5 Reinforcement Cover

The reinforcement shall be placed a clear distance of not less than 2 inches from the permanently cased or 3 inches from the uncased sides. When shafts are constructed in corrosive or marine environments, or when concrete is placed by the water or slurry displacement methods, the clear distance should not be less than 4 inches for uncased shafts and shafts with permanent casings not sufficiently corrosion resistant.

The reinforcement cage shall be centered in the hole using centering devices. All steel centering devices shall be epoxy coated.

4.6.6.2.6 Reinforcement into Superstructure

Sufficient reinforcement shall be provided at the junction of the shaft with the superstructure to make a suitable connection. The embedment of the reinforcement into the cap shall be in conformance with Articles 8.24 and 8.25.

4.6.6.3 Enlarged Bases

Enlarged bases shall be designed to insure that plain concrete is not overstressed. The enlarged base shall slope at a side angle not less than 30 degrees from the vertical and have a bottom diameter not greater than 3 times the diameter of the shaft. The thickness of the bottom edge of the enlarged base shall not be less than 6 inches.

4.6.6.4 Center-to-Center Shaft Spacing

The center-to-center spacing of drilled shafts should be 3B or greater to avoid interference between adjacent shafts during construction. If closer spacing is required, the sequence of construction shall be specified and the interaction effects between adjacent shafts shall be evaluated by the designer.

4.6.7 Load Testing

4.6.7.1 General

Where necessary, a full scale load test (or tests) should be conducted on a drilled shaft foundation(s) to confirm response to load. Load tests shall be conducted using a test shaft(s) constructed in a manner and of dimensions and materials identical to those planned for the produc-

tion shafts into the materials planned for support. Load testing should be conducted whenever special site conditions or combinations of load are encountered, or when structures of special design or sensitivity (e.g., large bridges) are to be supported on drilled shaft foundations.

4.6.7.2 Load Testing Procedures

Load tests shall be conducted following prescribed written procedures which have been developed from accepted standards (e.g., ASTM, 1989; Crowther, 1988) and modified, as appropriate, for the conditions at the site. Standard pile load testing procedures developed by the American Society for Testing and Materials which may be modified for testing drilled shafts include:

- ASTM D1143, Standard Method of Testing Piles Under Static Axial Compressive Load;
- ASTM D3689, Standard Method of Testing Individual Piles Under Static Axial Tensile Load; and
- ASTM D3966, Standard Method for Testing Piles Under Lateral Loads.

A simplified procedure for testing drilled shafts permitting determination of the relative contribution of side resistance and tip resistance to overall shaft capacity is also available (Osterberg, 1984).

As a minimum, the written test procedures should include the following:

- Apparatus for applying loads including reaction system and loading system.
- Apparatus for measuring movements.
- Apparatus for measuring loads.
- Procedures for loading including rates of load application, load cycling and maximum load.
- Procedures for measuring movements.
- Safety requirements.
- Data presentation requirements and methods of data analysis.
- Drawings showing the procedures and materials to be used to construct the load test apparatus.

As a minimum, the results of the load test(s) shall provide the load-deformation response at the butt of the shaft. When appropriate, information concerning ultimate load capacity, load transfer, lateral load-displacement with depth, the effects of shaft group interaction, the degree of fixity provided by caps and footings, and other data pertinent to the anticipated loading conditions on the production shafts shall be obtained.

4.6.7.3 Load Test Method Selection

Selection of an appropriate load test method shall be based on an evaluation of the anticipated types and duration of loads during service, and shall include consideration of the following:

- The immediate goals of the load test (i.e., to proof load the foundation and verify design capacity).
- The loads expected to act on the production foundation (compressive and/or uplift, dead and/or live) and the soil conditions predominant in the region of concern.
- The local practice or traditional method used in similar soil/rock deposits.
- Time and budget constraints.

Part C Strength Design Method Load Factor Design

Note to User: *Article Number 4.7 has been omitted intentionally.*

4.8 SCOPE

Provisions of this section shall apply for the design of spread footings, driven piles, and drilled shaft foundations.

4.9 DEFINITIONS

Batter Pile – A pile driven at an angle inclined to the vertical to provide higher resistance to lateral loads.

Combination End-Bearing and Friction Pile – Pile that derives its capacity from the contributions of both end bearing developed at the pile tip and resistance mobilized along the embedded shaft.

Deep Foundation – A foundation which derives its support by transferring loads to soil or rock at some depth below the structure by end bearing, by adhesion or friction or both.

Design Load – All applicable loads and forces or their related internal moments and forces used to proportion a foundation. In load factor design, design load refers to nominal loads multiplied by appropriate load factors.

Design Strength – The maximum load-carrying capacity of the foundation, as defined by a particular limit state. In load factor design, design strength is computed as the product of the nominal resistance and the appropriate performance factor.

Drilled Shaft – A deep foundation unit, wholly or partly embedded in the ground, constructed by placing fresh concrete in a drilled hole with or without steel reinforcement. Drilled shafts derive their capacities from the surrounding soil and/or from the soil or rock strata below their tips. Drilled shafts are also commonly referred to as caissons, drilled caissons, bored piles or drilled piers.

End-Bearing Pile – A pile whose support capacity is derived principally from the resistance of the foundation material on which the pile tip rests.

Factored Load – Load, multiplied by appropriate load factors, used to proportion a foundation in load factor design.

Friction Pile – A pile whose support capacity is derived principally from soil resistance mobilized along the side of the embedded pile.

Limit State – A limiting condition in which the foundation and/or the structure it supports are deemed to be unsafe (i.e., strength limit state), or to be no longer fully useful for their intended function (i.e., serviceability limit state).

Load Effect – The force in a foundation system (e.g., axial force, sliding force, bending moment, etc.) due to the applied loads.

Load Factor – A factor used to modify a nominal load effect, which accounts for the uncertainties associated with the determination and variability of the load effect.

Load Factor Design – A design method in which safety provisions are incorporated by separately accounting for uncertainties relative to load and resistance.

Nominal Load – A typical value or a code-specified value for a load.

Nominal Resistance – The analytically estimated load-carrying capacity of a foundation calculated using nominal dimensions and material properties, and established soil mechanics principles.

Performance Factor – A factor used to modify a nominal resistance, which accounts for the uncertainties associated with the determination of the nominal resistance and the variability of the actual capacity.

Pile – A relatively slender deep foundation unit, wholly or partly embedded in the ground, installed by driving, drilling, augering, jetting, or otherwise, and which derives its capacity from the surrounding soil and/or from the soil or rock strata below its tip.

Piping – Progressive erosion of soil by seeping water, producing an open pipe through the soil, through which water flows in an uncontrolled and dangerous manner.

Shallow Foundation – A foundation which derives its support by transferring load directly to the soil or rock at shallow depth. If a single slab covers the supporting stratum beneath the entire area of the superstructure, the foundation is known as a combined footing. If various parts of the structure are supported individually, the individual supports are known as spread footings, and the foundation is called a footing foundation.

4.10 LIMIT STATES, LOAD FACTORS, AND RESISTANCE FACTORS

4.10.1 General

All relevant limit states shall be considered in the design to ensure an adequate degree of safety and serviceability.

4.10.2 Serviceability Limit States

Service limit states for foundation design shall include:

- settlements, and
- lateral displacements.

The limit state for settlement shall be based upon rideability and economy. The cost of limiting foundation movements shall be compared to the cost of designing the superstructure so that it can tolerate larger movements, or of correcting the consequences of movements through maintenance, to determine minimum lifetime cost. More stringent criteria may be established by the owner.

4.10.3 Strength Limit States

Strength limit states for foundation design shall include:

- bearing resistance failure,
- excessive loss of contact,
- sliding at the base of footing,
- loss of overall stability, and
- structural capacity.

Foundations shall be proportioned such that the factored resistance is not less than the effects of factored loads specified in Section 3.

4.10.4 Strength Requirement

Foundations shall be proportioned by the methods specified in Articles 4.11 through 4.13 so that their design strengths are at least equal to the required strengths.

The required strength is the combined effect of the factored loads for each applicable load combination stipulated in Article 3.22. The design strength is calculated for each applicable limit state as the nominal resistance, R_n or q_n , multiplied by an appropriate performance (or resistance) factor, ϕ . Methods for calculating nominal resistance are provided in Articles 4.11 through 4.13, and values of performance factors are given in Article 4.10.6.

4.10.5 Load Combinations and Load Factors

Foundations shall be proportioned to withstand safely all load combinations stipulated in Article 3.22 which are applicable to the particular site or foundation type. With

the exception of the portions of concrete or steel piles that are above the ground line and are rigidly connected to the superstructure as in rigid frame or continuous structures, impact forces shall not be considered in foundation design. (See Article 3.8.1.)

Values of γ and β coefficients for load factor design, as given in Table 3.22.1A, shall apply to strength limit state considerations; while those for service load design (also given in Table 3.22.1B) shall apply to serviceability considerations.

+ **4.10.6 Performance Factors**

+ The performance (or resistance) factor, f , shall be as follows:

	Soil Bearing Pressure	Pile Capacity
Group Loads I through VI	$\phi = 0.50$	$= 0.75$
Group Loads VII	$= 1.00$	$= 1.00$

+ Structure Design will determine the required nominal resistance for piles based on the above performance factors. Geotechnical Services will determine the geotechnical capacity to meet or exceed the required nominal resistance. The safety margin between the required nominal resistance and the ultimate geotechnical capacity shall be determined by the Geotechnical Services considering the reliability of the ultimate soil capacity determination and pile installation control.

+ **4.11 SPREAD FOOTINGS**

+ **4.11.1 General Considerations**

+ **4.11.1.1 General**

Provisions of this Article shall apply to design of isolated footings, and where applicable, to combined footings. Special attention shall be given to footings on fill.

Footings shall be designed to keep the soil pressure as nearly uniform as practicable. The distribution of soil pressure shall be consistent with properties of the soil and the structure, and with established principles of soil mechanics.

4.11.1.2 Depth

The depth of footings shall be determined with respect to the character of the foundation materials and the possibility of undermining. Footings at stream crossings shall be founded at depth below the maximum anticipated depth of scour as specified in Article 4.11.1.3.

Footings not exposed to the action of stream current shall be founded on a firm foundation and below frost level.

Consideration shall be given to the use of either a geotextile or graded granular filter layer to reduce susceptibility to piping in rip rap or abutment backfill.

4.11.1.3 Scour Protection

Footings supported on soil or degradable rock strata shall be embedded below the maximum computed scour depth or protected with a scour counter-measure. Footings supported on massive, competent rock formations which are highly resistant to scour shall be placed directly on the cleaned rock surface. Where required, additional lateral resistance shall be provided by drilling and grouting steel dowels into the rock surface rather than blasting to embed the footing below the rock surface.

4.11.1.4 Frost Action

In regions where freezing of the ground occurs during the winter months, footings shall be founded below the maximum depth of frost penetration in order to prevent damage from frost heave.

4.11.1.5 Anchorage

Footings which are founded on inclined smooth solid rock surfaces and which are not restrained by an overburden of resistant material shall be effectively anchored by means of rock anchors, rock bolts, dowels, keys or other suitable means. Shallow keying of large footing areas shall be avoided where blasting is required for rock removal.

4.11.1.6 Groundwater

Footings shall be designed for the highest anticipated position of the groundwater table.

The influence of the groundwater table on bearing capacity of soils or rocks, and settlements of the structure shall be considered. In cases where seepage forces are present, they should also be included in the analyses.

4.11.1.7 Uplift

Where foundations may be subjected to uplift forces, they shall be investigated both for resistance to pullout and for their structural strength.

4.11.1.8 Deterioration

Deterioration of the concrete in a foundation by sulfate, chloride, and acid attack should be investigated. Laboratory testing of soil and groundwater samples for sulfates, chloride and pH should be sufficient to assess deterioration potential. When chemical wastes are suspected, a more thorough chemical analyses of soil and groundwater samples should be considered.

4.11.1.9 Nearby Structures

In cases where foundations are placed adjacent to existing structures, the influence of the existing structures on the behavior of the foundation, and the effect of the foundation on the existing structures, shall be investigated.

4.11.2 Notations

B	= footing width (in length units)
B'	= reduced effective footing width (see Article 4.11.4.1.5) (in length units)
c	= soil cohesion (in units of force/length ²)
C _{w1} , C _{w2}	= correction factors for groundwater effect (dimensionless)
D _f	= depth to footing base (in length units)
D _w	= depth to groundwater table (in length units)
E _m	= elastic modulus of rock masses (in units of force/length ²)
i	= type of load
L'	= reduced effective length (see Article 4.11.4.1.5) (in length units)
L _i	= load type i
N	= average value of standard penetration test blow count (dimensionless)
N _m , N _{cm} , N _{qm}	= modified bearing capacity factors used in analytic theory (dimensionless)
q _c	= cone resistance (in units of force/length ²)
q _{max}	= maximum factored footing contact pressure (in units of force/length ²)
q _n	= nominal bearing resistance (in units of force/length ²)

q _{ult}	= ultimate bearing capacity (in units of force/length ²)
R _l	= reduction factor due to the effect of load inclination (dimensionless)
R _n	= nominal resistance
RQD	= rock quality designation
s	= span length (in length units)
s _u	= undrained shear strength of soil (in units of force/length ²)
β _i	= load factor coefficient for load type i (see Article C 4.10.4)
γ	= load factor (see Article C 4.10.4)
γ	= total (moist) unit weight of soil (see Article C 4.11.4.1.1)
δ	= differential settlement between adjacent footings
φ	= performance factor
φ _f	= friction angle of soil

4.11.3 Movement Under Serviceability Limit States

4.11.3.1 General

Movement of foundations in both vertical settlement and lateral displacement directions shall be investigated at service limit states.

Lateral displacement of a foundation shall be evaluated when:

- horizontal or inclined loads are present,
- the foundation is placed on an embankment slope,
- possibility of loss of foundation support through erosion or scour exists, or
- bearing strata are significantly inclined.

4.11.3.2 Loads

Immediate settlement shall be determined using the service load combinations given in Table 3.22.1B. Time dependent settlement shall be determined using only the permanent loads.

Settlement and horizontal movements caused by embankment loadings behind bridge abutments should be investigated.

In seismically active areas, consideration shall be given to the potential settlement of footings on sand resulting from ground motions induced by earthquake loadings.

4.11.3.3 Movement Criteria

The vertical settlement criteria in Article 4.4.7.2.2 represents general conditions and should be modified if, in the Engineer's judgement, expected loads, service conditions, or foundation materials are different from those anticipated by the specifications.

+ Vertical and horizontal movement criteria for footings shall be developed consistent with the function and type of structure, anticipated service life, and consequences of unacceptable movements on structure performance. The tolerable movement criteria shall be established by empirical procedures or structural analyses.

4.11.3.4 Settlement Analyses

Foundation settlements shall be estimated using deformation analyses based on the results of laboratory or in-situ testing. The soil parameters used in the analyses shall be chosen to reflect the loading history of the ground, the construction sequence and the effect of soil layering.

Both total and differential settlements, including time effects, shall be considered.

4.11.3.4.1 Settlement of Footings on Cohesionless Soils

Estimates of settlement of cohesionless soils shall make allowance for the fact that settlements in these soils can be highly erratic.

No method should be considered capable of predicting settlements of footings on sand with precision.

Settlements of footings on cohesionless soils may be estimated using empirical procedures or elastic theory.

4.11.3.4.2 Settlement of Footings on Cohesive Soils

For foundations on cohesive soils, both immediate and consolidation settlements shall be investigated. If the footing width is small relative to the thickness of a compressible soil, the effect of three-dimensional loading shall be considered. In highly plastic and organic clay, secondary settlements are significant and shall be included in the analysis.

4.11.3.4.3 Settlements of Footings on Rock

The magnitude of consolidation and secondary settlements in rock masses containing soft seams shall be estimated by applying procedures discussed in Article 4.11.3.4.2.

4.11.4 Safety Against Soil Failure

4.11.4.1 Bearing Capacity of Foundation Soils

Several methods may be used to calculate ultimate bearing capacity of foundation soils. The calculated value of ultimate bearing capacity shall be multiplied by an appropriate performance factor, as given in Article 4.10.6, to determine the factored bearing capacity.

Footings are considered to be adequate against soil failure if the factored bearing capacity exceeds the effect of factored design loads ($\phi q_n \geq q_{max}$).

4.11.4.1.1 Theoretical Estimation

The bearing capacity should be estimated using accepted soil mechanics theories based on measured soil parameters. The soil parameter used in the analysis shall be representative of the soil shear strength under the considered loading and subsurface conditions.

4.11.4.1.2 Semi-empirical Procedures

The bearing capacity of foundation soils may be estimated from the results of in-situ tests or by observing foundations on similar soils. The use of a particular in-situ test and the interpretation of the results shall take local experience into consideration. The following in-situ tests may be used:

- Standard penetration test (SPT)
- Cone penetration test (CPT), and
- Pressuremeter test.

4.11.4.1.3 Plate Loading Test

Bearing capacity may be determined by load tests providing that adequate subsurface explorations have been made to determine the soil profile below the foundation.

The bearing capacity determined from a load test may be extrapolated to adjacent footings where the subsurface profile is similar.

Plate load test shall be performed in accordance with the procedures specified in ASTM Standard D 1194-87 or AASHTO Standard T 235-74.

4.11.4.1.4 *Presumptive Values*

Presumptive values for allowable bearing pressures on soil and rock, given in Table 4.11.4.1.4-1, shall be used only for guidance, preliminary design or design of temporary structures. The use of presumptive values shall be based on the results of subsurface exploration to identify soil and rock conditions. All values used for design shall be confirmed by field and/or laboratory testing.

The values given in Table 4.11.4.1.4-1 are applicable directly for working stress procedures. When these values are used for preliminary design, all load factors shall be taken as unity.

4.11.4.1.5 *Effect of Load Eccentricity*

For loads eccentric to the centroid of the footing, a reduced effective footing area ($B' \times L'$) shall be used in design. The reduced effective area is always concentrically loaded, so that the design bearing pressure on the reduced effective area is always uniform.

Footings under eccentric loads shall be designed to ensure that: (1) the product of the bearing capacity and an appropriate performance factor exceeds the effect of vertical design loads, and (2) eccentricity of loading, evaluated based on factored loads, is less than $1/4$ of the footing dimension in any direction for footings on soils.

For structural design of an eccentrically loaded foundation, a triangular or trapezoidal contact pressure distribution based on factored loads shall be used.

4.11.4.1.6 *Effect of Groundwater Table*

Ultimate bearing capacity shall be determined based on the highest anticipated position of groundwater level at the footing location. In cases where the groundwater table is at a depth less than 1.5 times the footing width below the bottom of the footing, reduction of bearing capacity, as a result of submergence effects, shall be considered.

4.11.4.2 **Bearing Capacity of Foundations on Rock**

The bearing capacity of footings on rock shall consider the presence, orientation and condition of

discontinuities, weathering profiles and other similar profiles as they apply at a particular site, and the degree to which they shall be incorporated in the design.

For footings on competent rock, reliance on simple and direct analyses based on uniaxial compressive rock strengths and RQD may be applicable. Competent rock shall be defined as a rock mass with discontinuities that are tight or open not wider than one-eighth inch. For footings on less competent rock, more detailed investigations and analyses shall be performed to account for the effects of weathering, and the presence and condition of discontinuities.

Footings on rocks are considered to be adequate against bearing capacity failure if the product of the ultimate bearing capacity determined using procedures described in Articles 4.11.4.2.1 through 4.11.4.2.3 and an appropriate performance factor exceeds the effect of design loads.

4.11.4.2.1 *Semi-empirical Procedures*

Bearing capacity of foundations on rock may be determined using empirical correlation with RQD or other systems for evaluating rock mass quality, such as the Geomechanic Rock Mass Rating (RMR) system, or Norwegian Geotechnical Institute (NGI) Rock Mass Classification System. The use of these semi-empirical procedures shall take local experience into consideration.

4.11.4.2.2 *Analytic Method*

The ultimate bearing capacity of foundations on rock shall be determined using established rock mechanics principles based on the rock mass strength parameters. The influence of discontinuities on the failure mode shall also be considered.

4.11.4.2.3 *Load Test*

Where appropriate, load tests may be performed to determine the bearing capacity of foundations on rock.

4.11.4.2.4 *Presumptive Bearing Values*

For simple structures on good quality rock masses, values of presumptive bearing pressure given in Table 4.11.4.2.4-1 may be used for preliminary design. The use of presumptive values shall be based on the results of subsurface exploration to identify rock conditions. All

**TABLE 4.11.4.1.4-1 Presumptive Allowable Bearing Pressures for Spread Footing Foundations
(Modified after U.S. Department of the Navy, 1982)**

Type of Bearing Material	Consistency in Place	Allowable Bearing Pressure (tsf)	
		Ordinary Range	Recommended Value for Use
Massive crystalline igneous and metamorphic rock: graphite, diorite, basalt, gneiss, thoroughly cemented conglomerate (sound condition allows minor cracks)	Very hard, sound rock	60 to 100	80
Foliated metamorphic rock: slate, schist (sound condition allows minor cracks)	Hard sound rock	30 to 40	35
Sedimentary rock: hard cemented shales, siltstone, sandstone, limestone without cavities	Hard sound rock	15 to 25	20
Weathered or broken bedrock of any kind except highly argillaceous rock (shale)	Medium hard rock	8 to 12	10
Compaction shale or other highly argillaceous rock in sound condition	Medium hard rock	8 to 12	10
Well-graded mixture of fine- and coarse-grained soil: glacial till, hardpan, boulder clay (GW-GC, GC, SC)	Very dense	8 to 12	10
Gravel, gravel-sand mixtures, boulder-gravel mixtures (GW, GP, SW, SP)	Very dense	6 to 10	7
	Medium dense to dense	4 to 7	5
	Loose	2 to 6	3
Coarse to medium sand, sand with little gravel (SW, SP)	Very dense	4 to 6	4
	Medium dense to dense	2 to 4	3
	Loose	1 to 3	1.5
Fine to medium sand, silty or clayey medium to coarse sand (SW, SM, SC)	Very dense	3 to 5	3
	Medium dense to dense	2 to 4	2.5
	Loose	1 to 2	1.5
Fine sand, silty or clayey medium to fine sand (SP, SM, SC)	Very dense	3 to 5	3
	Medium dense to dense	2 to 4	2.5
	Loose	1 to 2	1.5
Homogeneous inorganic clay, sandy or silty clay (CL, CH)	Very stiff to hard	3 to 6	4
	Medium stiff to stiff	1 to 3	2
Inorganic silt, sandy or clayey silt, varved silt-clay fine sand (ML, MH)	Soft	0.5 to 1	0.5
	Very stiff to hard	2 to 4	3
	Medium stiff to stiff	1 to 3	1.5
	Soft	0.5 to 1	0.5

values used in design shall be confirmed by field and/or laboratory testing. The values given in Table 4.11.4.2.4-1 are directly applicable to working stress procedure, i.e., all the load factors shall be taken as unity.

4.11.4.2.5 *Effect of Load Eccentricity*

If the eccentricity of loading on a footing is less than $\frac{1}{6}$ of the footing width, a trapezoidal bearing pressure shall be used in evaluating the bearing capacity. If the eccentricity is between $\frac{1}{6}$ and $\frac{1}{4}$ of the footing width, a triangular bearing pressure shall be used. The maximum bearing pressure shall not exceed the product of the ultimate bearing capacity multiplied by a suitable performance factor. The eccentricity of loading evaluated using factored loads shall not exceed $\frac{3}{8}$ (37.5%) of the footing dimensions in any direction.

4.11.4.3 **Failure by Sliding**

Failure by sliding shall be investigated for footings that support inclined loads and/or are founded on slopes.

For foundations on clay soils, possible presence of a shrinkage gap between the soil and the foundation shall be considered. If passive resistance is included as part of the shear resistance required for resisting sliding, consideration shall also be given to possible future removal of the soil in front of the foundation.

4.11.4.4 **Loss of Overall Stability**

The overall stability of footings, slopes and foundation soil or rock, shall be evaluated for footings located on or near a slope using applicable factored load combinations in Article 3.22 and a performance factor of 0.75.

4.11.5 **Structural Capacity**

The structural design of footings shall comply to the provisions given in Article 4.4.11 and Article 8.16.

4.11.6 **Construction Considerations for Shallow Foundations**

4.11.6.1 **General**

The ground conditions should be monitored closely during construction to determine whether or not the ground conditions are as foreseen and to enable prompt intervention, if necessary. The control investigation should be performed and interpreted by experienced and

qualified engineers. Records of the control investigations should be kept as part of the final project data, among other things, to permit a later assessment of the foundation in connection with rehabilitation, change of neighboring structures, etc.

4.11.6.2 **Excavation Monitoring**

Prior to concreting footings or placing backfill, an excavation shall be free of debris and excessive water.

Monitoring by an experienced and trained person should always include a thorough examination of the sides and bottom of the excavation, with the possible addition of pits or borings to evaluate the geological conditions.

The assumptions made during the design of the foundations regarding strength, density, and groundwater conditions should be verified during construction, by visual inspection.

4.11.6.3 **Compaction Monitoring**

Compaction shall be carried out in a manner so that the fill material within the section under inspection is as close as practicable to uniform. The layering and compaction of the fill material should be systematic everywhere, with the same thickness of layer and number of passes with the compaction equipment used as for the inspected fill. The control measurements should be undertaken in the form of random samples.

4.12 **DRIVEN PILES**

4.12.1 **General**

The provisions of the specifications in Articles 4.5.1 through 4.5.21 with the exception of Article 4.5.6, shall apply to strength design (load factor design) of driven piles. Article 4.5.6 covers the allowable stress design of piles and shall be replaced by the articles in this section for load factor design of driven piles, unless otherwise stated.

4.12.2 **Notations**

a_s	= pile perimeter
A_p	= area of pile tip
A_s	= surface area of shaft of pile
CPT	= cone penetration test

TABLE 4.11.4.2.4-1 Presumptive Bearing Pressures (tsf) for Foundations on Rock (After Putnam, 1981)

Code	Year ¹	Bedrock ²	Sound Foliated Rock	Sound Sedimentary Rock	Soft Rock ³	Soft Shale	Broken Shale
Baltimore	1962	100	35	...	10	...	(⁴)
BOCA	1970	100	40	25	10	4	1.5
Boston	1970	100	50	10	10	...	(⁴)
Chicago	1970	100	100
Cleveland	1951/1969	25
Dallas	1968	.2q _u ⁵	.2q _u	.2q _u	.2q _u	.2q _u	.2q _u
Detroit	1956	100	100	9,600	.12	12	...
Indiana	1967	.2q _u	.2q _u	.2q _u	.2q _u	.2q _u	.2q _u
Kansas City	1961/1969	.2q _u	.2q _u	.2q _u	.2q _u	.2q _u	.2q _u
Los Angeles	1970	10	4	3	1	1	1
New York City	1970	60	60	60	8
New York State	...	100	40	15
Ohio	1970	100	40	15	10	4	...
Philadelphia	1969	50	15	10-15	8
Pittsburgh	1959/1969	25	25	25	8	8	...
Richmond	1968	100	40	25	10	4	1.5
St. Louis	1960/1970	100	40	25	10	1.5	1.5
San Francisco	1969	3-5	3-5	3-5
Uniform Building Code	1970	.2q _u	.2q _u	.2q _u	.2q _u	.2q _u	.2q _u
NBC Canada	1970	100
New South Wales, Australia	1974	33	13	4.5	...

Note: 1-Year of code or original year and date of revision.

2-Massive crystalline bedrock.

3-Soft and broken rock, not including shale.

4-Allowable bearing pressure to be determined by appropriate city official.

5-q_u = unconfined compressive strength.

d	= dimensionless depth factor for estimating tip capacity of piles in rock	H _s	= depth of embedment of pile socketed into rock
D	= pile width or diameter	I	= influence factor for the effective group embedment
D'	= effective depth of pile group	I _p	= moment of inertia of a pile
D _b	= depth of embedment of pile into a bearing stratum	K	= coefficient of lateral earth pressure
D _s	= diameter of socket	K _c	= correction factor for sleeve friction in clay
e _x	= eccentricity of load in the x-direction	K _s	= correction factor for sleeve friction in sand
e _y	= eccentricity of load in the y-direction	K _{sp}	= dimensionless bearing capacity coefficient
E _p	= Young's modulus of a pile	L _f	= depth to point considered when measuring sleeve friction
E _s	= soil modulus	n _h	= rate of increase of soil modulus with depth
f _s	= sleeve friction measured from a CPT at point considered	\bar{N}	= Standard Penetration Test (SPT) blow count
H	= distance between pile tip and a weaker underlying soil layer	N	= average uncorrected (SPT) blow count along pile shaft

N_{corr} = average SPT-N value corrected for effect of overburden
 N_{pile} = number of piles in a pile group
 OCR = overconsolidation ratio
 P_D = unfactored dead load
 P_g = factored total axial load acting on a pile group
 $P_{x,y}$ = factored axial load acting on a pile in a pile group; the pile has coordinates (X,Y) with respect to the centroidal origin in the pile group
 PI = plasticity index
 q = net foundation pressure
 q_c = static cone resistance
 q_l = limiting tip resistance
 q_o = limiting tip resistance in lower stratum
 q_p = ultimate unit tip resistance
 q_s = ultimate unit side resistance
 q_u = average uniaxial compressive strength of rock cores
 q_{ult} = ultimate bearing capacity
 Q_p = ultimate load carried by tip of pile
 Q_s = ultimate load carried by shaft of pile
 Q_{ug} = ultimate uplift resistance of a pile group or a group of drilled shafts
 Q_{ult} = ultimate bearing capacity
 R = characteristic length of soil-pile system in cohesive soils
 s_d = spacing of discontinuities
 S = average spacing of piles
 S_u = undrained shear strength
 SPT = Standard Penetration Test
 S_u = average undrained shear strength along pile shaft
 t_d = width of discontinuities
 T = characteristic length of soil-pile system in cohesionless soils
 W_g = weight of block of soil, piles and pile cap
 x = distance of the centroid of the pile from the centroid of the pile cap in the x-direction
 X = width of smallest dimension of pile group
 y = distance of the centroid of the pile from the centroid of the pile cap in the y-direction
 Y = length of pile group or group of drilled shafts
 Z = total embedded pile length
 α = adhesion factor applied to S_u
 β = coefficient relating the vertical effective stress and the unit skin friction of a pile or drilled shaft
 γ = effective unit weight of soil
 δ = angle of shearing resistance between soil and pile

λ = empirical coefficient relating the passive lateral earth pressure and the unit skin friction of a pile
 η = pile group efficiency factor
 ρ = settlement
 ρ_{tol} = tolerable settlement
 σ'_h = horizontal effective stress
 σ'_v = vertical effective stress
 v_{av} = average shear stress along side of pile
 ϕ = performance factor
 ϕ_g = performance factor for the bearing capacity of a pile group failing as a unit consisting of the piles and the block of soil contained within the piles
 ϕ_q = performance factor for the total ultimate bearing capacity of a pile
 ϕ_{qs} = performance factor for the ultimate shaft capacity of a pile
 ϕ_{qp} = performance factor for the ultimate tip capacity of a pile
 ϕ_u = Performance factor for the uplift capacity of a single pile
 ϕ_{ug} = performance factor for the uplift capacity of pile groups

4.12.3 Selection of Design Pile Capacity

Piles shall be designed to have adequate bearing and structural capacity, under tolerable settlements and tolerable lateral displacements.

The supporting capacity of piles shall be determined by static analysis methods based on soil-structure interaction. Capacity may be verified with pile load test results, use of wave equation analysis, use of the dynamic pile analyzer or, less preferably, use of dynamic formulas.

4.12.3.1 Factors Affecting Axial Capacity

See Article 4.5.6. 1. 1. The following sub-articles shall supplement Article 4.5.6.1.1.

4.12.3.1.1 Pile Penetration

Piling used to penetrate a soft or loose upper stratum overlying a hard or firm stratum, shall penetrate the hard or firm stratum by a sufficient distance to limit lateral and vertical movement of the piles, as well as to attain sufficient vertical bearing capacity.

4.12.3.1.2 *Groundwater Table and Buoyancy*

Ultimate bearing capacity shall be determined using the groundwater level consistent with that used to calculate load effects. For drained loading, the effect of hydrostatic pressure shall be considered in the design.

4.12.3.1.3 *Effect Of Settling Ground and Downdrag Forces*

Possible development of downdrag loads on piles shall be considered where sites are underlain by compressible clays, silts or peats, especially where fill has recently been placed on the earlier surface, or where the groundwater is substantially lowered. Downdrag loads shall be considered as a load when the bearing capacity and settlement of pile foundations are investigated. Downdrag loads shall not be combined with transient loads.

The downdrag loads may be calculated, as specified in Article 4.12.3.3.2 with the direction of the skin friction forces reversed. The factored downdrag loads shall be added to the factored vertical dead load applied to the deep foundation in the assessment of bearing capacity. The effect of reduced overburden pressure caused by the downdrag shall be considered in calculating the bearing capacity of the foundation.

The downdrag loads shall be added to the vertical dead load applied to the deep foundation in the assessment of settlement at service limit states.

4.12.3.1.4 *Uplift*

Pile foundations designed to resist uplift forces should be checked both for resistance to pullout and for structural capacity to carry tensile stresses. Uplift forces can be caused by lateral loads, buoyancy effects, and expansive soils.

4.12.3.2 **Movement Under Serviceability Limit State**

4.12.3.2.1 *General*

For purposes of calculating the settlements of pile groups, loads shall be assumed to act on an equivalent footing located at two-thirds of the depth of embedment of the piles into the layer which provide support as shown in Figure 4.12.3.2.1-1.

Service loads for evaluating foundation settlement

shall include both the unfactored dead and live loads for piles in cohesionless soils and only the unfactored dead load for piles in cohesive soils.

Service loads for evaluating lateral displacement of foundations shall include all lateral loads in each of the load combinations as given in Article 3.22.

4.12.3.2.2 *Tolerable Movement*

Tolerable axial and lateral movements for driven pile foundations shall be developed consistent with the function and type of structure, fixity of bearings, anticipated service life and consequences of unacceptable displacements on performance of the structure.

4.12.3.2.3 *Settlement*

The settlement of a pile foundation shall not exceed the tolerable settlement, as selected according to Article 4.12.3.2.2.

4.12.3.2.3a *Cohesive Soil*

Procedures used for shallow foundations shall be used to estimate the settlement of a pile group, using the equivalent footing location shown in Figure 4.12.3.2.1-1.

4.12.3.2.3b *Cohesionless Soil*

The settlement of pile groups in cohesionless soils can be estimated using results of in situ-tests, and the equivalent footing location shown in Figure 4.12.3.2.1-1.

4.12.3.2.4 *Lateral Displacement*

The lateral displacement of a pile foundation shall not exceed the tolerable lateral displacement, as selected according to Article 4.12.3.2.2.

The lateral displacement of pile groups shall be estimated using procedures that consider soil-structure interaction.

4.12.3.3 **Resistance at Strength Limit States**

The strength limit states that shall be considered include:

- bearing capacity of piles,
- uplift capacity of piles,
- punching of piles in strong soil into a weaker layer, and
- structural capacity of the piles.

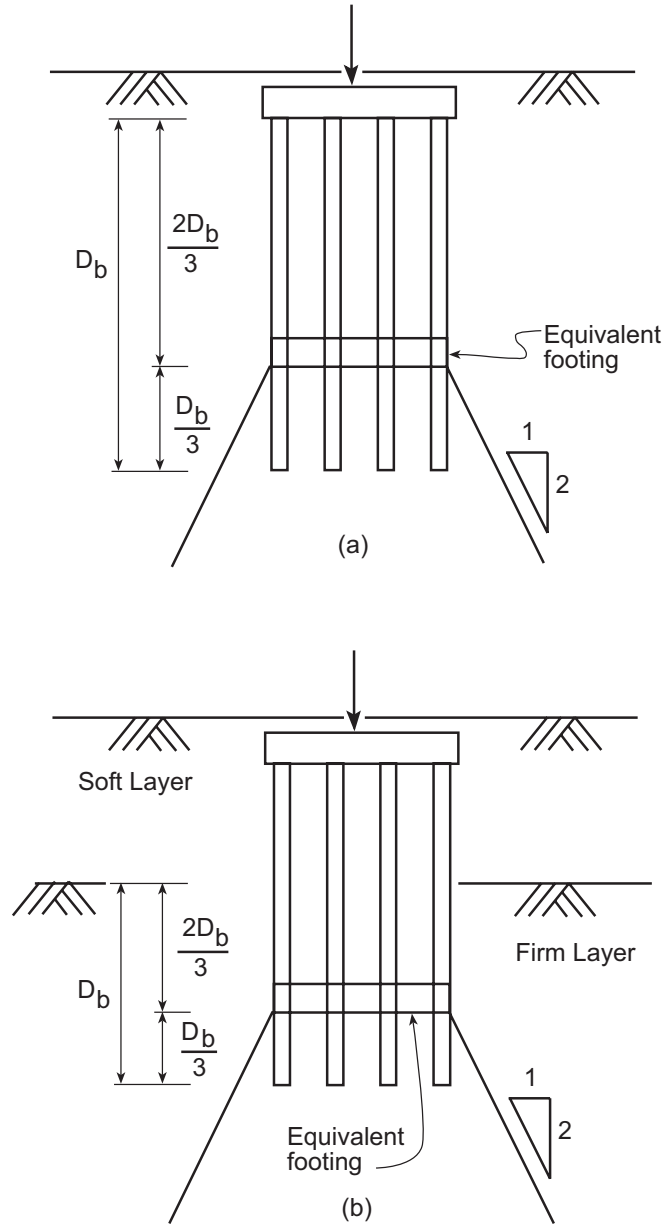

Figure 4.12.3.2.1-1 Location of Equivalent Footing (After Duncan and Buchignani, 1976)

4.12.3.3.1 Axial Loading of Piles

Preference shall be given to a design process based upon static analyses in combination with either field monitoring during driving or load tests. Load test results may be extrapolated to adjacent substructures with similar subsurface conditions. The ultimate bearing capacity of piles may be estimated using analytic methods or in-situ test methods.

4.12.3.3.2 Analytic Estimates of Pile Capacity

Analytic methods may be used to estimate the ultimate bearing capacity of piles in cohesive and cohesionless soils. Both total and effective stress methods may be used provided the appropriate soil strength parameters are evaluated.

4.12.3.3.3 Pile of Capacity Estimates Based on In-Situ Tests

In-situ test methods may be used to estimate the ultimate axial capacity of piles.

4.12.3.3.4 Piles Bearing on Rock

For piles driven to weak rock such as shales and mudstones or poor quality weathered rock, the ultimate tip capacity shall be estimated using semi-empirical methods.

4.12.3.3.5 Pile Load Test

The load test method specified in ASTM D 1143-81 may be used to verify the pile capacity. Tensile load testing of piles shall be done in accordance with ASTM D 3689-83. Lateral load testing of piles shall be done in accordance with ASTM D 3966-81.

4.12.3.3.6 Presumptive End Bearing Capacities

Presumptive values for allowable bearing pressures given in Table 4.11.4.1.4-1 on soil and rock shall be used only for guidance, preliminary design or design of temporary structures. The use of presumptive values shall be based on the results of subsurface exploration to identify soil and rock conditions. All values used for design shall be confirmed by field and/or laboratory testing.

4.12.3.3.7 Uplift

Uplift shall be considered when the force effects calculated based on the appropriate strength limit state load combinations are tensile.

When piles are subjected to uplift, they should be investigated for both resistance to pullout and structural ability to resist tension.

4.12.3.3.7a Single Pile Uplift Capacity

Friction piles may be considered to resist an intermittent but not sustained uplift. Uplift resistance may be equivalent to 40 percent of the ultimate structural compressive load capacity for Groups I through VI loadings and 50 percent of the ultimate structural compressive load capacity for Groups VII loading. Adequate pile anchorage, tensile strength, and geotechnical capacity must be provided.

4.12.3.3.7b Pile Group Uplift Capacity

The ultimate uplift capacity of a pile group shall be estimated as the lesser of the sum of the individual pile uplift capacities, or the uplift capacity of the pile group considered as a block. The block mechanism for cohesionless soil shall be taken as provided in Figure C4.12.3.7.2-1 and for cohesive soils as given in Figure C4.12.3.7.2-2. Buoyant unit weights shall be used for soil below the groundwater level.

4.12.3.3.8 Lateral Load

The effects of soil-structure or rock-structure interaction between the piles and ground, including the number and spacing of the piles in the group, shall be accounted for in the design of laterally loaded piles.

4.12.3.3.9 Batter Pile

The bearing capacity of a pile group containing batter piles may be estimated by treating the batter piles as vertical piles.

4.12.3.3.10 Group Capacity

4.12.3.3.10a Cohesive Soil

If the cap is not in firm contact with the ground, and if the soil at the surface is soft, the individual capacity of

+ each pile shall be multiplied by an efficiency factor η ,
 + where $\eta = 1.0$ for a center-to-center (CTC) spacing of 6B
 + or greater, for a CTC of less than 6B the Division of
 + Structural Foundations should be consulted to determine
 + the value of η .

If the cap is not in firm contact with the ground and if the soil is stiff, then no reduction in efficiency shall be required.

If the cap is in firm contact with the ground, then no reduction in efficiency shall be required.

The group capacity shall be the lesser of:

- the sum of the modified individual capacities of each pile in the group, or
- the capacity of an equivalent pier consisting of the piles and a block of soil within the area bounded by the piles.

For the equivalent pier, the full shear strength of soil shall be used to determine the skin friction resistance, the total base area of the equivalent pier shall be used to determine the end bearing resistance, and the additional capacity of the cap shall be ignored.

4.12.3.3.10b Cohesionless Soil

The ultimate bearing capacity of pile groups in cohesionless soil shall be the sum of the capacities of all the piles in the group. The efficiency factor, η shall be 1.0 where the pile cap is, or is not, in contact with the ground.

4.12.3.3.10c Pile Group in Strong Soil Overlying a Weak or Compressible Soil

If a pile group is embedded in a strong soil deposit overlying a weaker deposit, consideration shall be given to the potential for a punching failure of the pile tips into the weaker soil stratum. If the underlying soil stratum consists of a weaker compressible soil, consideration shall be given to the potential for large settlements in that weaker layer.

+ 4.12.3.3.11 Deleted

4.12.4 Structural Design

The structural design of driven piles shall be in accordance with the provisions of Articles 4.5.7, which was developed for allowable stress design procedures. To use load factor design procedures for the structural design of

driven piles, the load factor design procedures for reinforced concrete, prestressed concrete and steel in Sections 8, 9, and 10, respectively, shall be used in place of the allowable stress design procedures.

4.12.4.1 Buckling of Piles

Stability of piles shall be considered when the piles extend through water or air for a portion of their lengths.

4.12.5 Deleted

4.13 DRILLED SHAFTS

4.13.1 General

The provisions of the specifications in Articles 4.6.1 through 4.6.7 with the exception of Article 4.6.5, shall apply to the strength design (load factor design) of drilled shafts. Article 4.6.5 covers the allowable stress design of drilled shafts, and shall be replaced by the articles in this section for load factor design of drilled shafts, unless otherwise stated.

The provisions of Article 4.13 shall apply to the design of drilled shafts, but not drilled piles installed with continuous flight augers that are concreted as the auger is being extracted.

4.13.2 Notations

a	=	parameter used for calculating F_r
A_p	=	area of base of drilled shaft
A_s	=	surface area of a drilled pier
A_{soc}	=	cross-sectional area of socket
A_u	=	annular space between bell and shaft
b	=	perimeter used for calculating F_r
CPT	=	cone penetration test
d	=	dimensionless depth factor for estimating tip capacity of drilled shafts in rock
D	=	diameter of drilled shaft
D_b	=	embedment of drilled shaft in layer that provides support
D_p	=	diameter of base of a drilled shaft
D_s	=	diameter of a drilled shaft socket in rock
E_c	=	Young's modulus of concrete
E_i	=	intact rock modulus
E_p	=	Young's modulus of a drilled shaft
E_r	=	modulus of the in-situ rock mass
E_s	=	soil modulus
F_r	=	reduction factor for tip resistance of large diameter drilled shaft

H_s	= depth of embedment of drilled shaft socketed into rock
I_p	= moment of inertia of a drilled shaft
I_p	= influence coefficient (see Figure C4.13.3.3.4-1)
I_π	= influence coefficient for settlement of drilled shafts socketed in rock
k	= factor that reduces the tip capacity for shafts with a base diameter larger than 20 inches so as to limit the shaft settlement to 1 inch
K	= coefficient of lateral earth pressure or load transfer factor
K_b	= dimensionless bearing capacity coefficient for drilled shafts socketed in rock using pressuremeter results
K_E	= modulus modification ratio
K_{sp}	= dimensionless bearing capacity coefficient (see Figure C4.13.3.3.4-4)
LL	= liquid limit of soil
N	= uncorrected Standard Penetration Test (SPT) blow count
N_c	= bearing capacity factor
N_{corr}	= corrected SPT-N value
N_u	= uplift bearing capacity factor
p1	= limit pressure determined from pressuremeter tests within 2D above and below base of shaft
P_o	= at rest horizontal stress measured at the base of drilled shaft
P_D	= unfactored dead load
PL	= plastic limit of soil
q_p	= Ultimate unit tip resistance
q_{pr}	= reduced ultimate unit tip resistance of drilled shafts
q_s	= ultimate unit side resistance
q_s bell	= unit uplift capacity of a belled drilled shaft
q_u	= uniaxial compressive strength of rock core
q_{ult}	= ultimate bearing capacity
Q_p	= ultimate load carried by tip of drilled shaft
Q_s	= ultimate load carried by side of drilled shaft
Q_{SR}	= ultimate side resistance of drilled shafts socketed in rock
Q_{ult}	= total ultimate bearing capacity
R	= characteristic length of soil-drilled shaft system in cohesive soils
RQD	= Rock Quality Designation
s_d	= spacing of discontinuities
SPT	= Standard Penetration Test
S_u	= undrained shear strength
t_d	= width of discontinuities
T	= characteristic length of soil-drilled shaft system in cohesionless soils

z	= depth below ground surface
Z	= total embedded length of drilled shaft

Greek

α	= adhesion factor applied to S_u
β	= coefficient relating the vertical effective stress and the unit skin friction of a drilled shaft
γ'	= effective unit weight of soil
δ	= angle of shearing resistance between soil and drilled shaft
η	= drilled shaft group efficiency factor
ρ_{base}	= settlement of the base of the drilled shaft
ρ_e	= elastic shortening of drilled shaft
ρ_{tol}	= tolerable settlement
σ'_v	= vertical effective stress
σ_v	= total vertical stress
ΣP_i	= working load at top of socket
ϕ	= performance factor
ϕ' or ϕ_f	= angle of internal friction of soil
ϕ_q	= performance factor for the total ultimate bearing capacity of a drilled shaft
ϕ_{qs}	= performance factor for the ultimate shaft capacity of a drilled shaft
ϕ_{qp}	= performance factor for the ultimate tip capacity of a drilled shaft

4.13.3 Geotechnical Design

Drilled shafts shall be designed to have adequate bearing and structural capacities under tolerable settlements and tolerable lateral movements.

The supporting capacity of drilled shafts shall be estimated by static analysis methods (analytical methods based on soil-structure interaction). Capacity may be verified with load test results.

The method of construction may affect the drilled shaft capacity and shall be considered as part of the design process. Drilled shafts may be constructed using the dry, casing or wet method of construction, or a combination of methods.

4.13.3.1 Factors Affecting Axial Capacity

See Article 4.6.5.2 for drilled shafts in soil and Article 4.6.5.3.3 for drilled shafts in rock. The following sub-articles shall supplement Articles 4.6.5.2 and 4.6.5.3.3.

4.13.3.1.1 Downdrag Loads

Downdrag loads shall be evaluated, where appropriate, as indicated in Article 4.12.3.1.3.

4.13.3.1.2 Uplift

The provisions of Article 4.12.3.1.4 shall apply as applicable.

Shafts designed for and constructed in expansive soil shall extend for a sufficient depth into moisture-stable soils to provide adequate anchorage to resist uplift. Sufficient clearance shall be provided between the ground surface and underside of caps or beams connecting shafts to preclude the application of uplift loads at the shaft/cap connection due to swelling ground conditions. Uplift capacity of straight-sided drilled shafts shall rely only on side resistance in conformance with Article 4.13.3.3.2 for drilled shafts in cohesive soils, and Article 4.13.3.3.3 for drilled shafts in cohesionless soils. If the shaft has an enlarged base, Q_s shall be determined in conformance with Article 4.13.3.3.6.

4.13.3.2 Movement Under Serviceability Limit State

4.13.3.2.1 General

The provisions of Article 4.12.3.2.1 shall apply as applicable.

In estimating settlements of drilled shafts in clay, only unfactored permanent loads shall be considered. However unfactored live loads must be added to the permanent loads when estimating settlement of shafts in granular soil.

4.13.3.2.2 Tolerable Movement

The provisions of Article 4.12.3.2.2 shall apply as applicable.

4.13.3.2.3 Settlement

The settlement of a drilled shaft foundation involving either single drilled shafts or groups of drilled shafts shall not exceed the tolerable settlement as selected according to Article 4.13.3.2.2

4.13.3.2.3a Settlement of Single Drilled Shafts

The settlement of single drilled shafts shall be estimated considering short-term settlement, consolidation

settlement (if constructed in cohesive soils), and axial compression of the drilled shaft.

4.13.3.2.3b Group Settlement

The settlement of groups of drilled shafts shall be estimated using the same procedures as described for pile groups, Article 4.12.3.2.3.

- Cohesive Soil, See Article 4.12.3.2.3a
- Cohesionless Soil, See Article 4.12.3.2.3b

4.13.3.2.4 Lateral Displacement

The provisions of Article 4.12.3.2.4 shall apply as applicable.

4.13.3.3 Resistance at Strength Limit States

The strength limit states that must be considered include: (1) bearing capacity of drilled shafts, (2) uplift capacity of drilled shafts, and (3) punching of drilled shafts bearing in strong soil into a weaker layer below.

4.13.3.3.1 Axial Loading of Drilled Shafts

The provisions of Article 4.12.3.3.1 shall apply as applicable.

4.13.3.3.2 Analytic Estimates of Drilled Shaft Capacity in Cohesive Soils

Analytic (rational) methods may be used to estimate the ultimate bearing capacity of drilled shafts in cohesive soils.

4.13.3.3.3 Estimation of Drilled-Shaft Capacity in Cohesionless Soils

The ultimate bearing capacity of drilled shafts in cohesionless soils shall be estimated using applicable methods, and the factored capacity selected using judgment, and any available experience with similar conditions.

4.13.3.3.4 Axial Capacity in Rock

In determining the axial capacity of drilled shafts with rock sockets, the side resistance from overlying soil deposits shall be ignored.

If the rock is degradable, consideration of special construction procedures, larger socket dimensions, or reduced socket capacities shall be considered.

4.13.3.3.5 Load Test

Where necessary, a full scale load test or tests shall be conducted on a drilled shaft or shafts to confirm response to load. Load tests shall be conducted using shafts constructed in a manner and of dimensions and materials identical to those planned for the production shafts.

Load tests shall be conducted following prescribed written procedures which have been developed from accepted standards and modified, as appropriate, for the conditions at the site. Standard pile load testing procedures developed by the American Society for Testing and Materials as specified in Article 4.12.3.3.5 may be modified for testing drilled shafts.

4.13.3.3.6 Uplift Capacity

Uplift shall be considered when (i) upward loads act on the drilled shafts and (ii) swelling or expansive soils act on the drilled shafts. Drilled shafts subjected to uplift forces shall be investigated, both for resistance to pullout and for their structural strength.

4.13.3.3.6a Uplift Capacity of a Single Drilled Shaft

The uplift capacity of a single straight-sided drilled shaft shall be estimated in a manner similar to that for estimating the ultimate side resistance for drilled shafts in compression (Articles 4.13.3.3.2, 4.13.3.3.3, and 4.13.3.3.4).

The uplift capacity of a belled shaft shall be estimated neglecting the side resistance above the bell, and assuming that the bell behaves as an anchor.

4.13.3.3.6b Group Uplift Capacity

See Article 4.12.3.3.7b

4.13.3.3.7 Lateral Load

The design of laterally loaded drilled shafts is usually governed by lateral movement criteria (Article 4.13.3.2) or structural failure of the drilled shaft. The design of laterally loaded drilled shafts shall account for the effects of interaction between the shaft and ground, including the number of piers in the group.

4.13.3.3.8 Group Capacity

Possible reduction in capacity from group effects shall be considered.

4.13.3.3.8a Cohesive Soil

The provisions of Article 4.12.3.3.10a shall apply.

4.13.3.3.8b Cohesionless Soil

Evaluation of group capacity of shafts in cohesionless soil shall consider the spacing between adjacent shafts. Regardless of cap contact with the ground, the individual capacity of each shaft shall be reduced by a factor η for an isolated shaft, where $\eta = 1.0$ for a center-to-center (CTC) spacing of 8 diameters or greater, for a CTC of less than 8 diameters the Division of Structural Foundations should be consulted to determine the value of η .

4.13.3.3.8c Group in Strong Soil Overlying Weaker Compressible Soil

The provisions of Article 4.12.3.3.10c shall apply as applicable.

4.13.3.3.9 Deleted

4.13.4 Structural Design

The structural design of drilled shafts shall be in accordance with the provisions of Article 4.6.6, which was developed for allowable stress design procedures. In order to use load factor design procedures for the structural design of drilled shafts, the load factor design procedures in Section 8 for reinforced concrete shall be used in place of the allowable stress design procedures.

4.13.4.1 Buckling of Drilled Shafts

Stability of drilled shafts shall be considered when the shafts extend through water or air for a portion of their length.