

# **CHAPTER # 4**

# **ANALYSIS AND DESIGN OF BEAMS**

## **1/2**

**Teacher:**

**Dr. Ali Ahmed**

**Book by:**

**Prof. Dr. Zahid Ahmed SIDDIQUE**



**Department of Civil Engineering  
University of Engineering & Technology  
Lahore**

# ANALYSIS AND DESIGN OF BEAMS

## INTRODUCTION

A beam is a structural member in which the major deformation is **bending**.

The bending moment is primarily generated due to **transverse loads**. This member carries the loads throughout its span and transfers it to its ends with or without accompanying moment.

Beam is a combination of a compression member on one side of neutral axis and a tension member on the other side, joined together through a shear element.

Following terms are used for various types of beams according to their use:

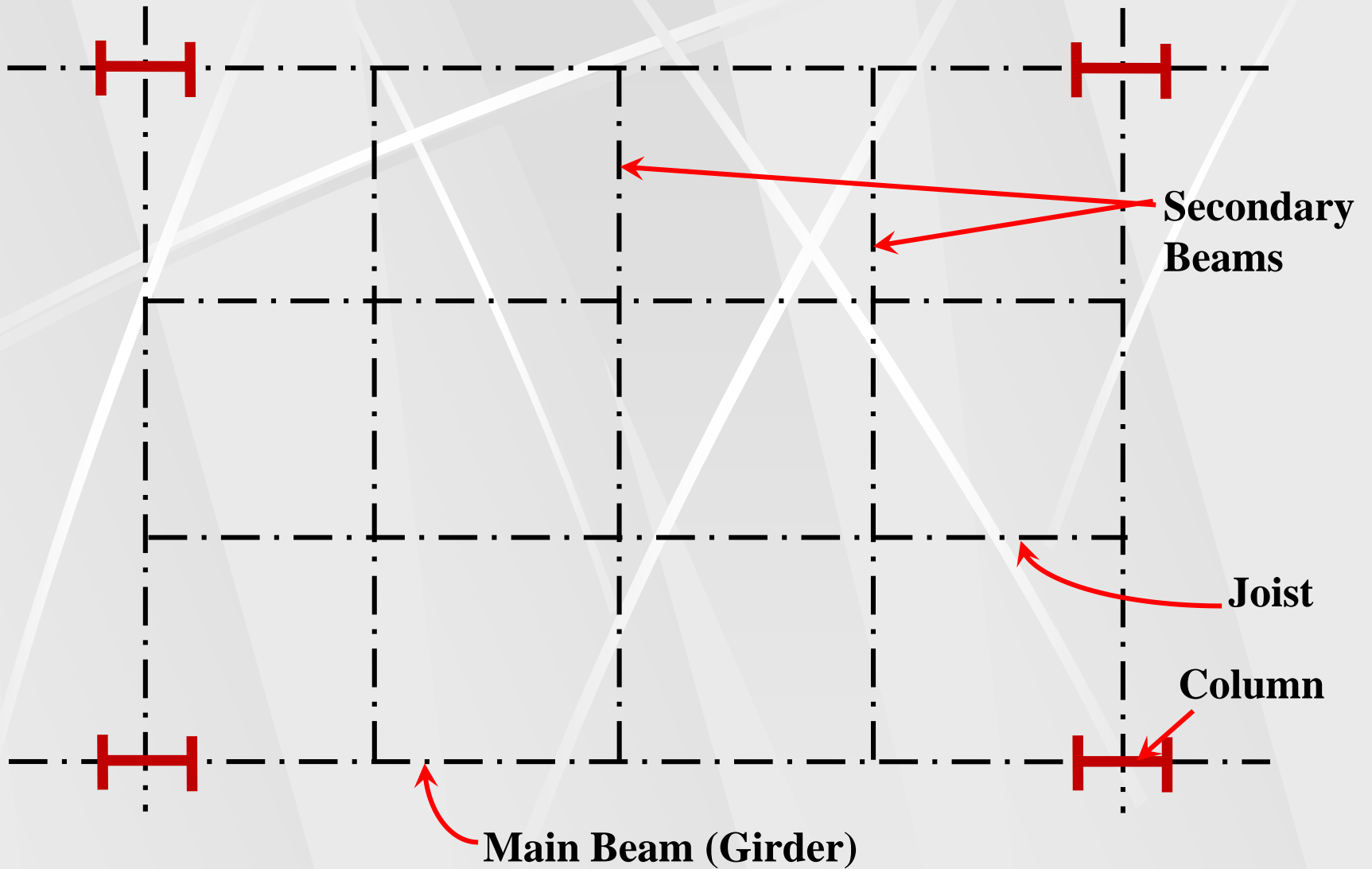
### **Girder:**

The primary beams that are frequently used at wide spacing supporting the smaller beams and other structural components are called girders.

Frequently, girders are made of built-up sections and carry heavier loads over larger spans. These are supported directly on columns (Figure 4.1).

### **Secondary Beam:**

These are relatively smaller beams resting on primary beams/girders carrying load of lesser part of roof and having smaller span lengths (Figure 4.1).



***Figure 4.1. Typical Plan of a Building Showing Layout of Columns and Beams***

**Joists:** Joists are less important beams that are closely spaced and are frequently having truss-type webs.

These are closely spaced smaller beams resting on secondary beams in majority of the cases.

With the presence of joists, the strength requirements of the roof sheathing or slab are greatly reduced (Figure 4.1).

**Purlins:** These are roof beams spanning between trusses.

Roof sheathing is connected with purlins, which is in turn are connected to panel points of the truss, with no direct connection between the roof and the truss top chord.

Uniformly distributed roof load is carried by the purlins and is converted into point loads acting at panel points of the truss.

Because of inclination of the load with the centroidal axes of the section and application of load on top chord, these beams are subjected to biaxial bending along with torsion.

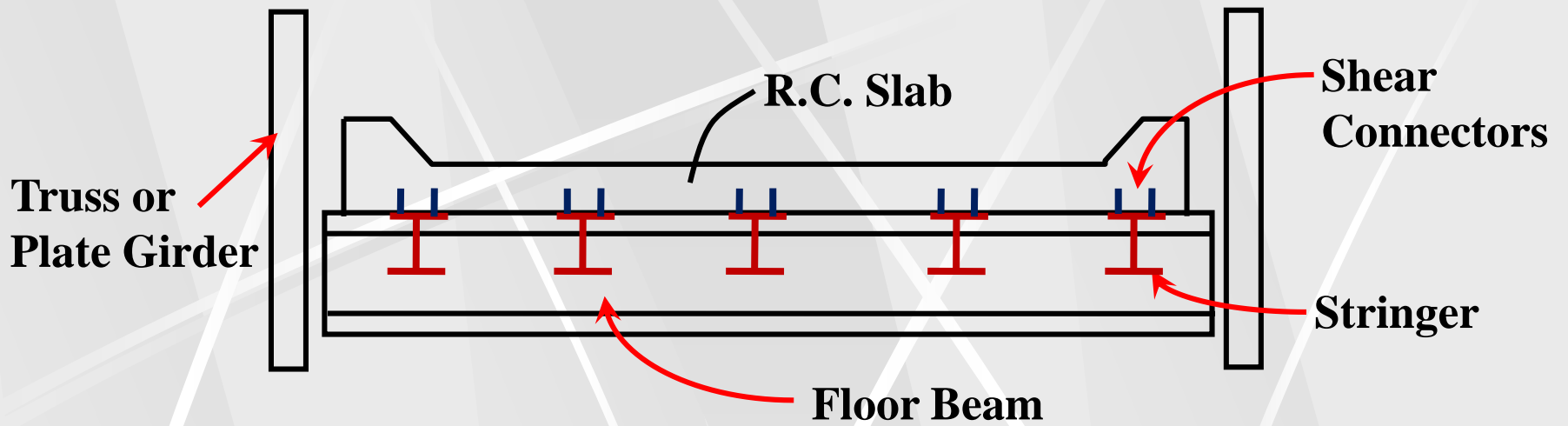
**Stringers:** Longitudinal bridge beams spanning between floor beams and placed parallel to roadway are called stringers (Figure 4.2).

**Floor Beams:** Floor beams are main girders of the bridge spanning between trusses or plate girders and running perpendicular to the roadway of the bridge (Figure 4.2).

**Girts:** Horizontal wall beams used to resist horizontal bending due to wind acting on the side of an industrial building are referred to as girts.

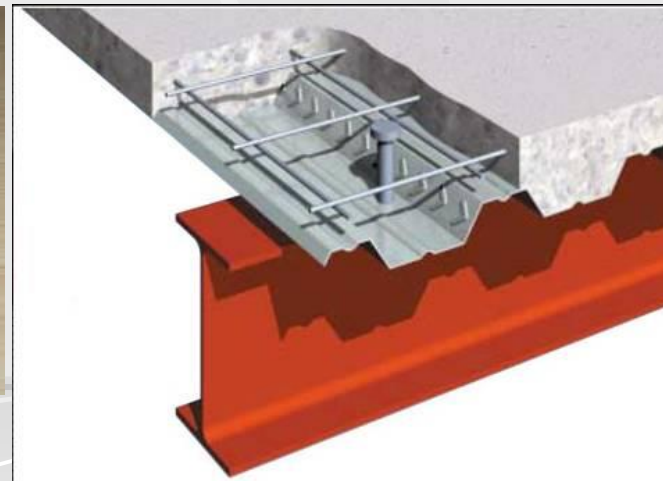


**Girts**



*Figure 4.2. Typical Cross-Section of a Steel Bridge.*

## Typical shear connectors for beams





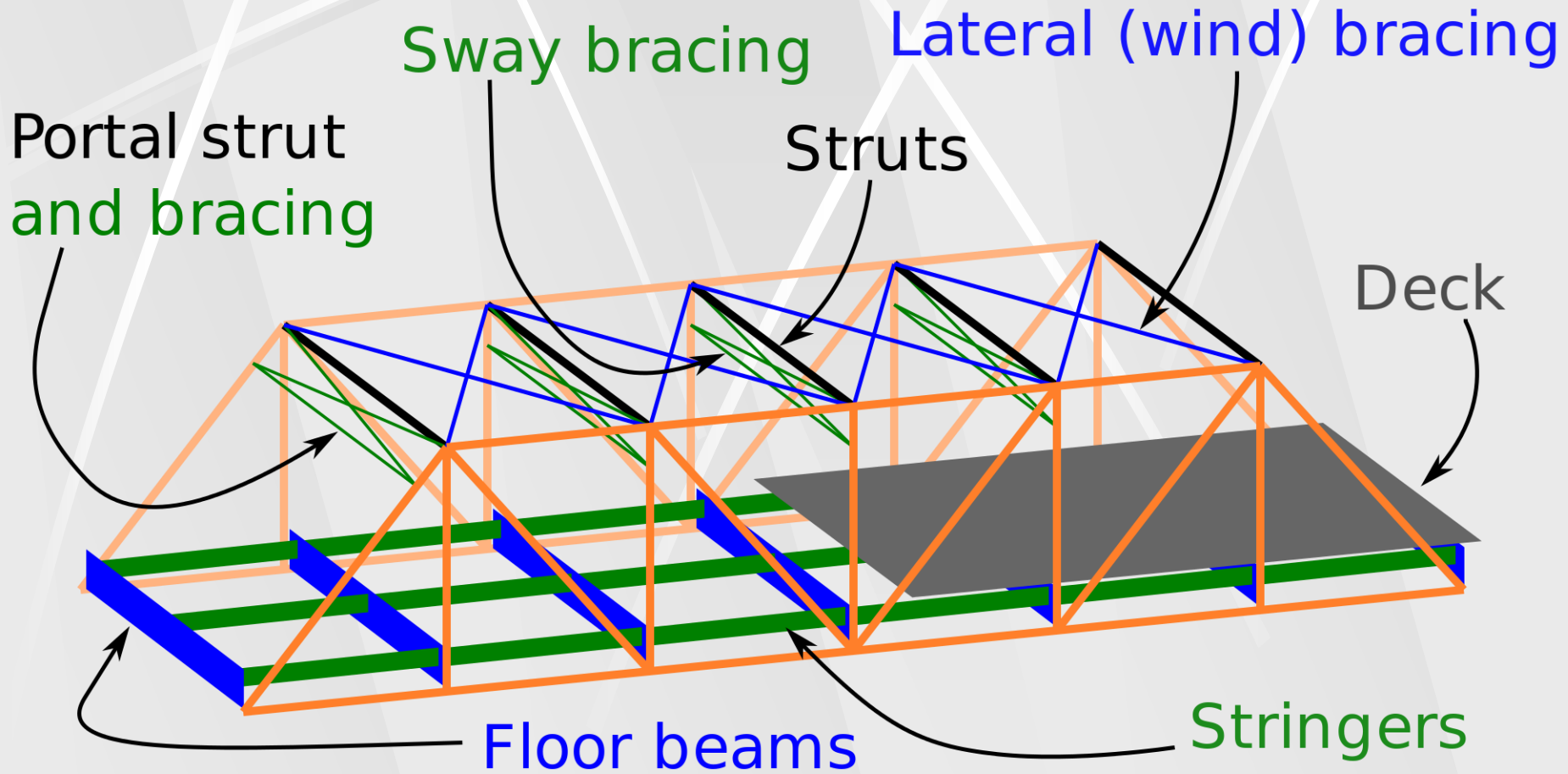
**Lintels:** Lintels are members supporting a wall over window or door openings.

**Spandrels:** In case of high-rise buildings, the masonry walls are usually not able to withstand their self-weight and the slab weight.

In such cases, beams are provided in exterior walls at each floor level to support the wall load and perhaps some roof load also.

These beams are termed as spandrels.

# STRUCTURAL COMPONENTS OF BRIDGE



# THE FLEXURE FORMULA

By denoting the elastic section modulus by  $S$  and the applied bending moment by  $M$ , the bending stresses may be calculated using the flexure formula as under:

Elastic bending stress,

$$F_b = \frac{M y}{I} = \frac{M}{I / y} = \frac{M}{S}$$

Using the above expression, the required section modulus to resist a particular bending moment may be obtained as follows:

$$S_{req} = \frac{M}{F_a}$$

Here,  $F_a$  = allowable bending stress

In a similar manner, plastic section modulus ( $Z$ ) to provide a particular ultimate moment capacity may be calculated for a laterally supported and compact section beam by using the formula:

$$Z_{req} = \frac{M_u}{\phi F_y}$$

## STABILITY OF BEAM SECTIONS

### *Local Stability*

If width over thickness ratio of the compression flange is greater than a certain limit, flange can buckle locally.

The phenomenon is called *Flange Local Buckling (FLB)* and is shown in Figure 4.3.

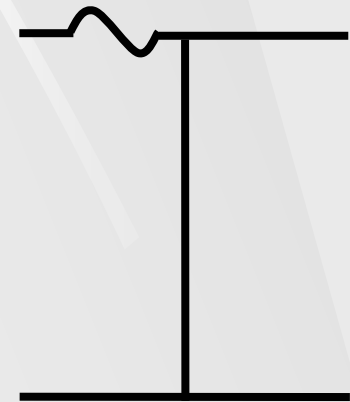


Figure 4.3. Flange Local Buckling

Similarly, if depth over thickness ratio is greater for the web, it can locally buckle or cripple under compression.

This phenomenon is called as *Web Local Buckling (WLB)*.

Web local buckling usually occurs in a diagonal position and is produced by the diagonal compression existing in the web due to shear.

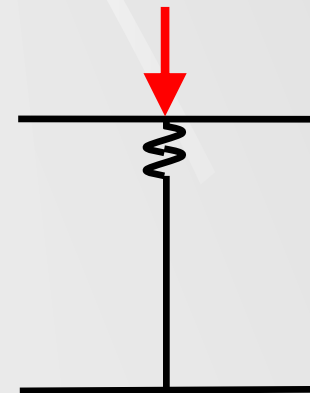
On the other hand, *Web Crippling* occurs due to local compression transferred by the flange to the connecting portion of web.

**Figure 4.4.**  
**Web Instability**

**Buckling is  
diagonal  
perpendicular to  
the paper**

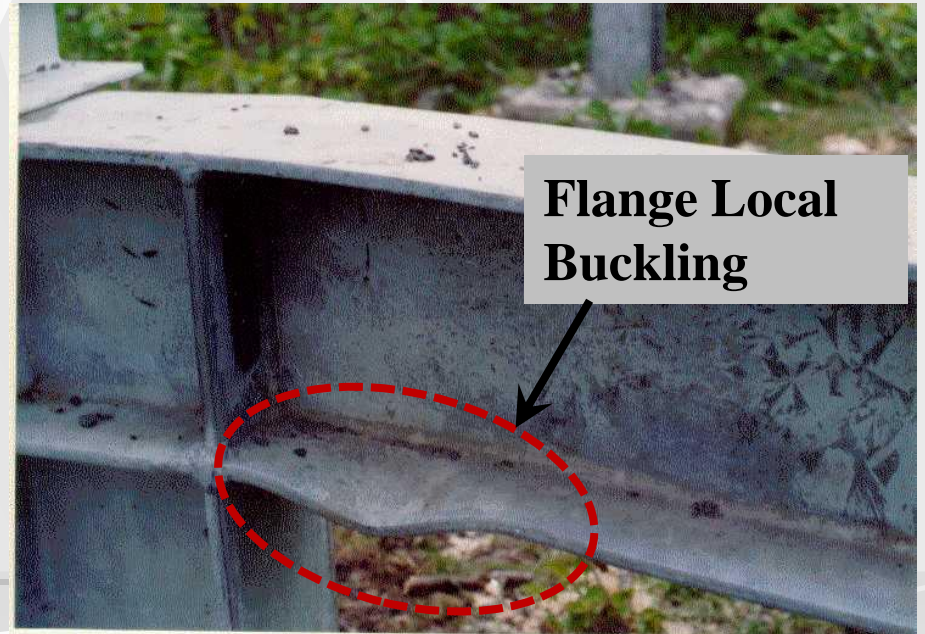
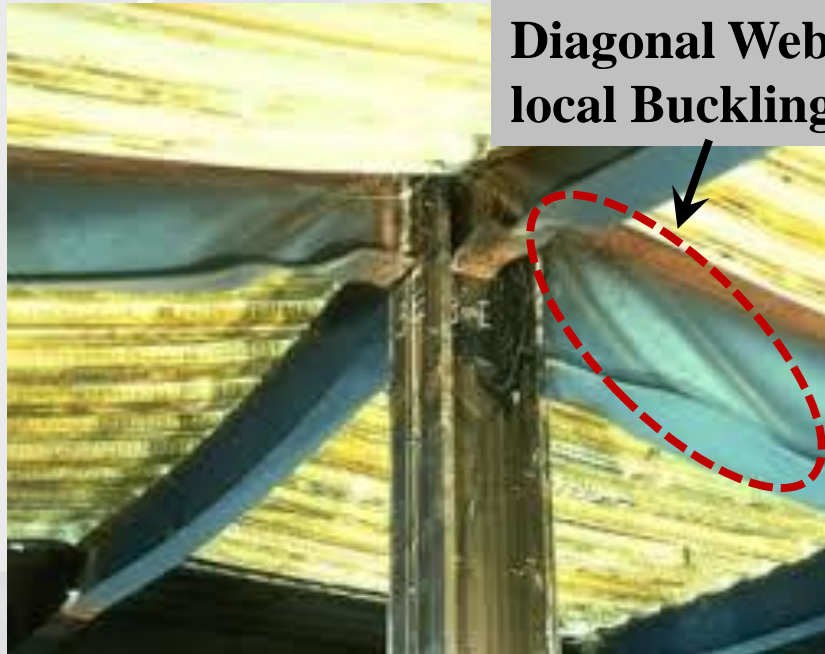


**(a) Web Local Buckling**

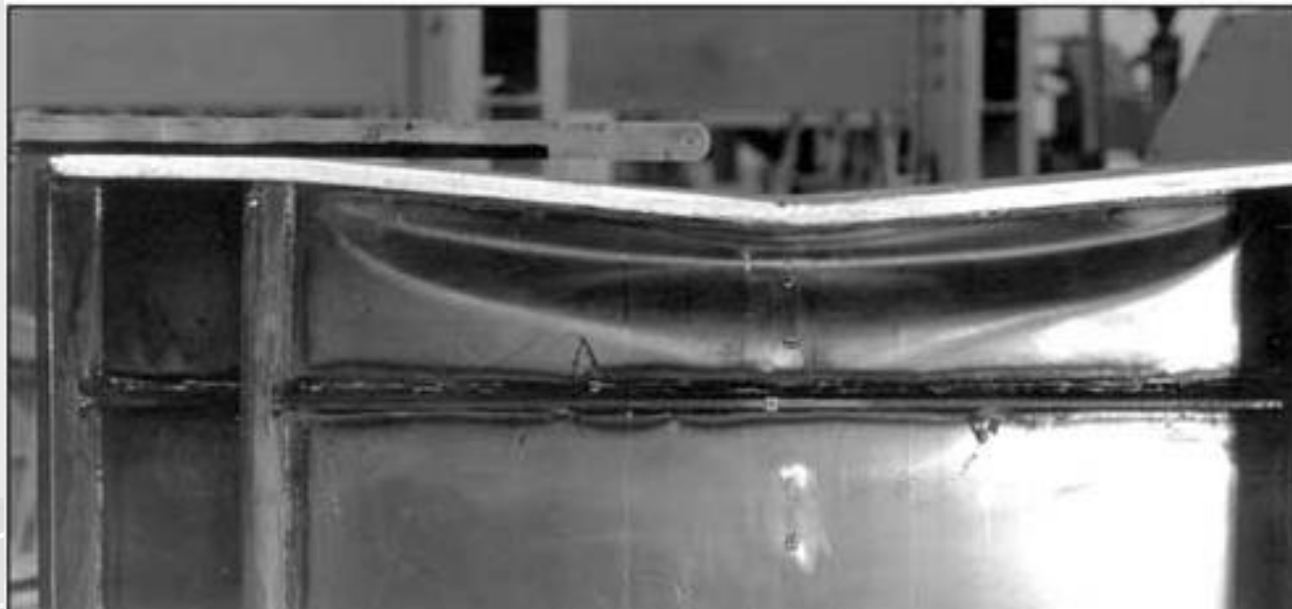


**(b) Web Crippling Due to  
Concentrated Load**

# ***LOCAL BUCKLING IN BEAM***



# *WEB CRIPPLING*

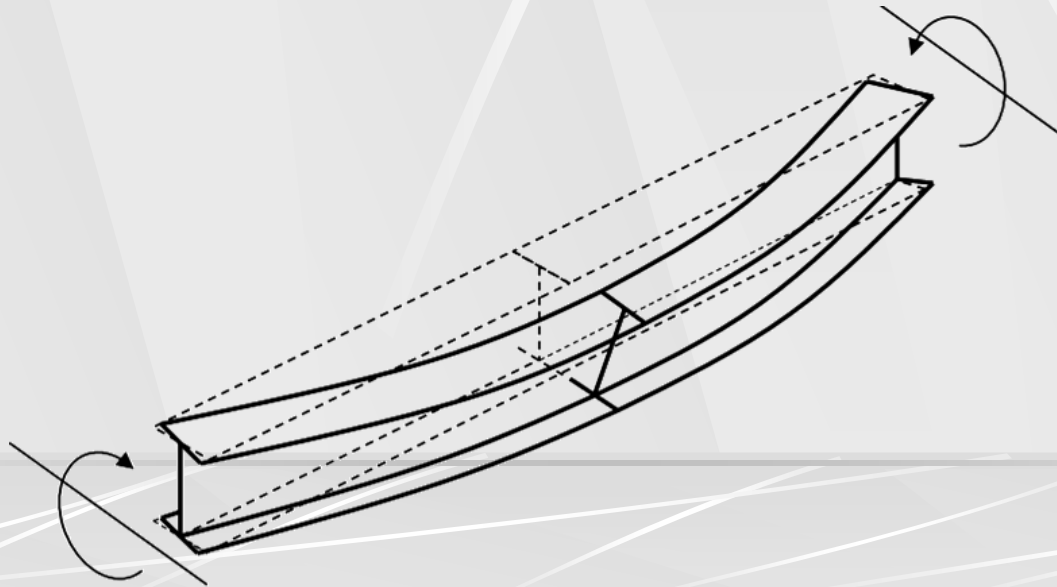


# LATERAL STABILITY

Due to lateral buckling of the compression zone, the section is twisted as a whole due to the fact that tension zone remains stable and tries to retain its position.

This combined twisting and buckling of beam in a lateral direction is called *Lateral Torsional Buckling (LTB)*.

It depends upon the laterally unsupported length besides the loading and the sectional dimensions.





## Unbraced or unsupported length of beam ( $L_b$ )

It is defined as the length of beam within its two sections whose compression flange is laterally supported or braced against twist of the cross section by perpendicular beams, slab or by some other means.

In other words, it is the distance between two points **braced against lateral displacement** of the compression flange denoted by  $L_b$ .

The sections braced to prevent twist of the member are considered better for the bracing against the lateral torsional buckling.

## Lateral stability against LTB

AISC-F2 deals with doubly symmetric compact I-shaped members and channels bent about their major axis.

These provisions are valid for sections having compact webs and compact flanges.

The nominal flexural strength ( $M_n$ ) is the lower value for limits states of *yielding* and *lateral - torsional buckling*.

A member will be safe against lateral torsional buckling up to its full plastic moment capacity if the unbraced length of the beam ( $L_b$ ) is not greater than  $L_p$ ,

*i.e.,*

$$L_b \leq L_p \quad \text{for no LTB}$$

where,

$L_p$  = Limiting laterally unbraced length for full plastic bending capacity ( $M_p = Z_x \times F_y$ ) in uniform moment case ( $C_b = 1.0$ ).

For I-shaped members including hybrid sections and channels

$$L_p = 1.76r_y \sqrt{\frac{E}{F_y}} \cong 50r_y \quad (\text{for A-36 Steel})$$

A section may develop yielding only at some points in case of *inelastic buckling*, when the unbraced length is between the two limiting lengths  $L_p$  and  $L_r$ , that is, when,

$$L_p < L_b \leq L_r$$

Where,

$L_r$  = Limiting laterally unbraced length for inelastic torsional buckling, mm.

$M_r$  = Limiting buckling moment dividing elastic and inelastic buckling for  $C_b = 1.0$ , ( $C_b$  will be defined later)  
 $= 0.7F_y S_x / 10^6$  kN-m

**For doubly symmetric I-shaped members:**

$$L_r = 1.95 r_{ts} \frac{E}{0.7F_y} \sqrt{\frac{Jc}{S_x h_o}} \sqrt{1 + \sqrt{1 + 6.76 \left( \frac{0.7F_y S_x h_o}{E Jc} \right)^2}}$$

$$L_r \approx 1.95 r_{ts} \frac{E}{0.7F_y} \quad \text{(very conservative estimate)}$$

$$r_{ts}^2 = \frac{\sqrt{I_y C_w}}{S_x} = \frac{I_y h_o}{2S_x} \quad \text{for doubly symmetric I-sections}$$

$r_{ts} \approx$  Radius of gyration of the compression flange plus one-sixth of the web for doubly symmetric I-sections

**OR**

$$r_{ts} = \frac{b_f}{\sqrt{12 \left( 1 + \frac{1}{6} \frac{h t_w}{b_f t_f} \right)}}$$

**c** = 1.0 for a doubly symmetric I-shape

**h<sub>o</sub>** = distance between the flange centroids

$$= d - t_f$$

**C<sub>w</sub>** = warping torsional constant for the section, mm<sup>6</sup>

**For symmetrical sections**  $C_w = \frac{I_f h_o^2}{2} \approx \frac{I_y h_o^2}{4}$

**I<sub>f</sub>** = moment of inertia of one flange in lateral direction, mm<sup>4</sup>

**J** = torsional constant for the section, mm<sup>4</sup>

$$J \approx \sum \frac{1}{3} b t^3$$

For the above expression,  $b$  is the long dimension and  $t$  is the short dimension of any rectangular element of the section and summation is for all the elements of that section.

When  $L_b > L_r$

$$M_n = F_{cr} S_x \leq M_p$$

$F_{cr}$  = compression flange critical buckling stress

$$F_{cr} = \frac{C_b \pi^2 E}{\left(\frac{L_b}{r_{ts}}\right)^2} \sqrt{1 + 0.078 \frac{J c}{S_x h_o} \left(\frac{L_b}{r_{ts}}\right)}$$
$$\approx \frac{C_b \pi^2 E}{\left(L_b / r_{ts}\right)^2}$$

# TYPES OF BEAM SECTIONS

## *Types According to Section Stability*

Depending upon the stability, sectional shapes can be classified as compact, non-compact and slender sections. The details of this classification are explained in the following paragraphs.

### *Compact section*

A compact section is the one that is capable of developing its full plastic moment capacity before any local buckling occurs.

In order to qualify under this category, a member must meet the following requirements (Table B4.1 of AISC Specification):

1. *Web is continuously connected with the flange.*
2. *Flange local stability criterion is satisfied.*
3. *Web local buckling criterion is satisfied.*
4. *Lateral torsional buckling is absent.*

### *Flange local stability criterion*

Flange is locally stable when the width over thickness ratio ( $\lambda=b/t$ ) for the flange is lesser than the limiting slenderness parameter for compact element ( $\lambda_p$ ).

The parameter  $\lambda$  for flange may be calculated as  $b_f / 2t_f$  or  $b_f / t_f$  depending on the whether half of the flange undergoes buckling or the full flange acts as one element for buckling, respectively.

$$\lambda \leq \lambda_p$$



## $\lambda_p$ for compact section

1. Unstiffened flanges of I-shaped rolled beams, channels, tees and built-up doubly and single symmetric I-sections.

$$\lambda_p = 0.38\sqrt{E / F_y} \quad \lambda_p = \mathbf{10.8 \text{ for A-36 steel}}$$

2. Unstiffened legs of single angles.

$$\lambda_p = 0.54\sqrt{E / F_y} \quad \lambda_p = \mathbf{15.3 \text{ for A-36 steel}}$$

3. Stiffened flanges of HSS shapes

$$\lambda_p = 1.12\sqrt{E / F_y} \quad \lambda_p = \mathbf{31.8 \text{ for A-36 steel}}$$

## *Web local buckling criterion*

Web is locally stable when the following condition is satisfied

$$\lambda \leq \lambda_p \quad \text{where, } \lambda = h/t_w$$

and assumed web depth for stability (***h***) is defined as under:

***h<sub>w</sub>*** = twice the distance from the neutral axis to the inside face of the compression flange less the fillet or corner radius for rolled sections

### ***$\lambda_p$ for compact section***

1. For webs of doubly symmetric I-sections and channels:

$$\lambda_p = 3.76\sqrt{E / F_y} \quad \lambda_p = 107 \text{ for A-36 steel}$$

2. For webs of rectangular HSS ( $\lambda = h / t$ ):

$$\lambda_p = 2.42\sqrt{E / F_y} \quad \lambda_p = 68.7 \text{ for A-36 steel}$$

## *Lateral torsional buckling*

The member is laterally stable

$$\text{If } L_b \leq L_p \quad \text{when, } C_b = 1.0.$$

## **Non-compact section**

A non-compact section is the one, which can develop yielding at least on one of its outer edges before showing local instability.

The width-thickness ratio of one or more elements exceeds  $\lambda_p$ , but  $\lambda$  for all elements do not exceed  $\lambda_r$ . *The values of  $\lambda_r$  are given in Table 4.1.*

## **Slender section**

This type of section cannot develop yielding at any point within the cross-section before it shows local instability.

The width over thickness ratio of any element exceeds  $\lambda_r$ .

**Table 4.1.  $\lambda_r$  For Non-Compact Sections**

<b>Sr. No.</b>	<b>Type of Element</b>	<b>Expression For <math>\lambda_r</math></b>	<b><math>\lambda_r</math> for A36 steel</b>
<b>i)</b>	Unstiffened rolled flanges	$1.0\sqrt{E / F_y}$	28.4
<b>ii)</b>	Unstiffened flanges of doubly and singly symmetric built-up I-sections	$0.95\sqrt{\frac{Ek_c}{F_L}}$	to be calculated
<b>iii)</b>	Flexure in legs of single angles	$0.91\sqrt{E / F_y}$	25.8
<b>iv)</b>	Stiffened webs purely in flexure	$5.70\sqrt{E / F_y}$	162

## In table 4.1

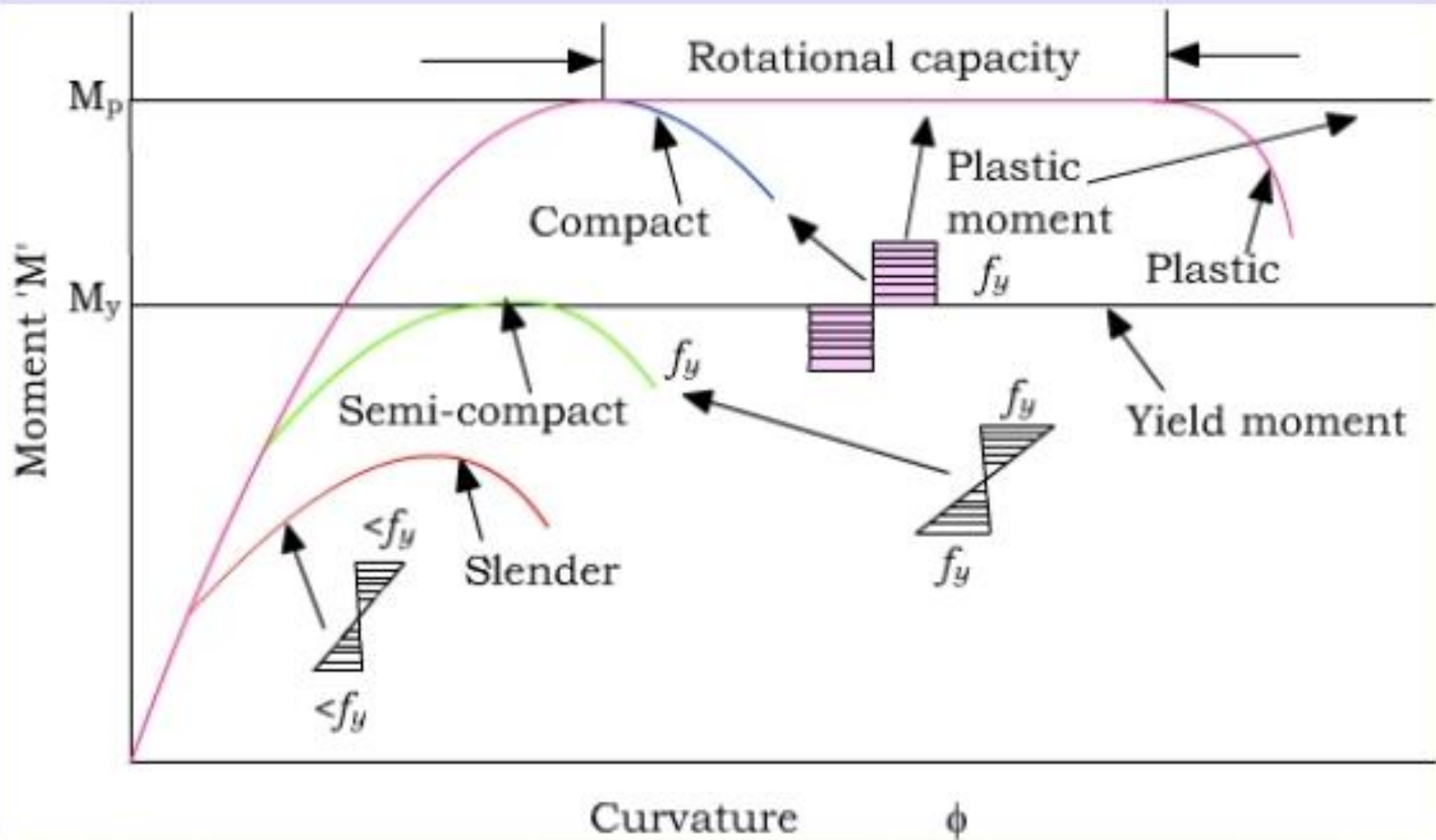
$F_L = 0.7F_y$  for minor axis bending, major axis bending of slender web of built-up I-shaped member and major axis bending of compact and non-compact webs of built-up I-sections with  $S_{xt} / S_{xc} \geq 0.7$ .

$= F_y (S_{xt} / S_{xc}) \geq 0.5 F_y$  for other cases.

$$k_c = \frac{4}{\sqrt{h/t_w}}$$

$K_c$  is between 0.35 and 0.76.

# Flexural Member Performance using Section Classification



# TYPES OF BEAMS

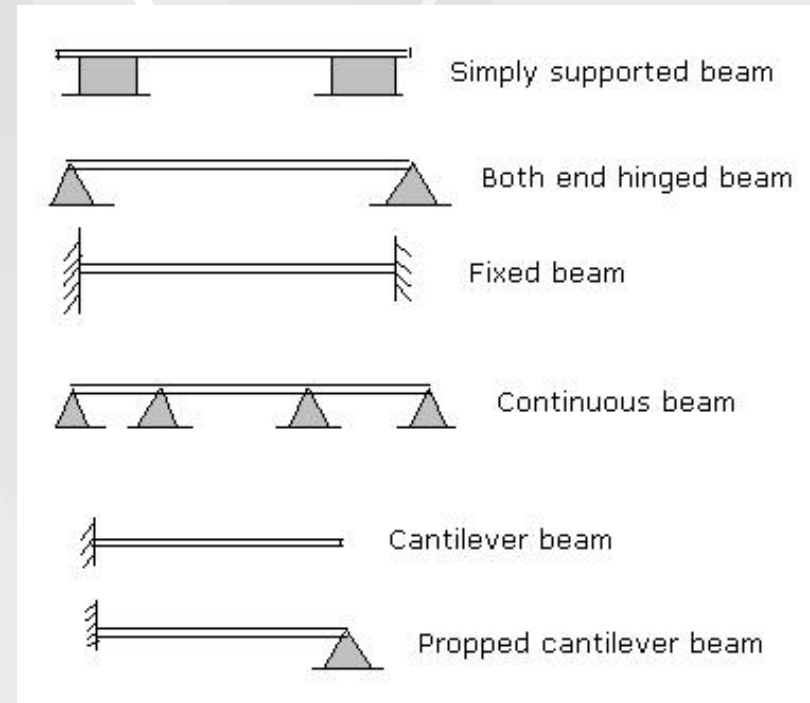
Depending on various aspects, the beams may be categorized as under:

## Position

- i. Central beams.
- ii. End beams.

## End Conditions

- i. Simple beams. The simple beams, girders and trusses have an effective length equal to the distance between centres of gravity of the members on which they rest.
- ii. Cantilever beams
- iii. Continuous beams
- iv. Fixed ended beams
- v. Propped cantilever beams



# Fabrication

## (a) Rolled steel sections

W-sections are most economic and widely used shapes as beams. However, beams may also be of S or M shapes. Angle and channel sections are used for smaller beams.

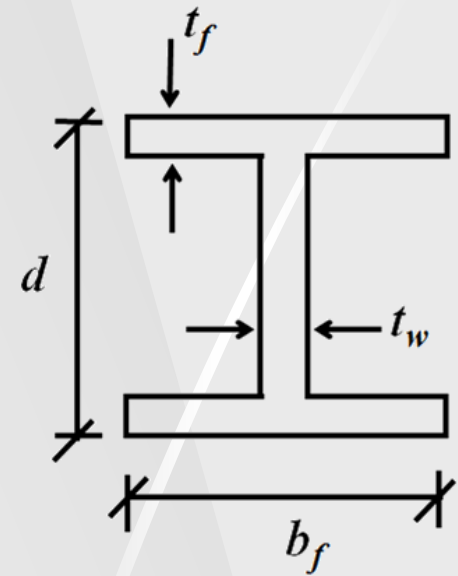


Figure 4.5. Standard Notation for Sizing of I- Section Beams

## (b) Cold formed beams

These are formed by bending high strength steel plates at room temperature, in the form of shapes shown in Figure 4.6, and are used for less loads and smaller spans.

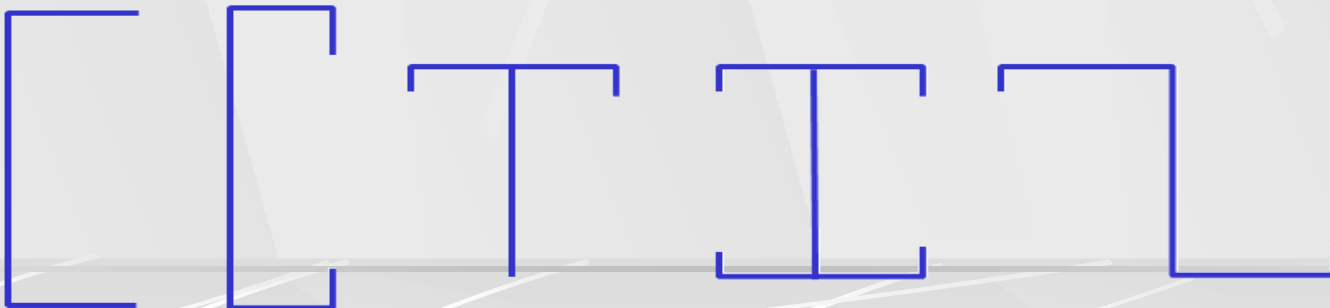


Figure 4.6. Cold Formed Shapes



### *(c) Built-up sections*

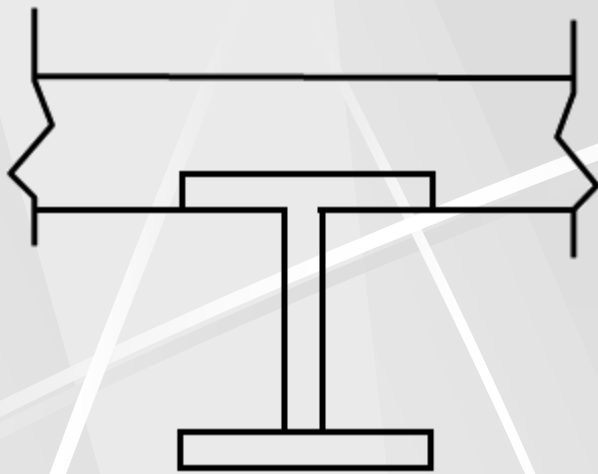
When the largest rolled steel section does not satisfy the requirements of loads or span exceeds approximately 12m, built-up sections are used.

Rolled steel sections with cover plates are used for spans up to approximately 14 m.

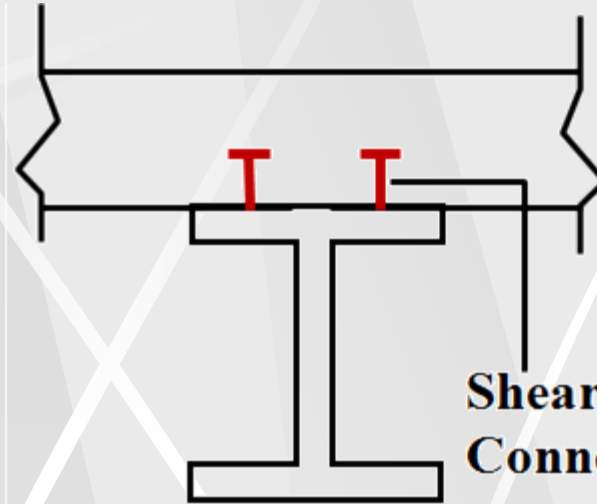
Typical built-up sections are shown in Figure 4.7.

### *(d) Composite sections*

When steel beams and some part of reinforced concrete slab act together due to some type of shear connection between the two, the resulting beam is said to have a composite section, as shown in Figure 4.8.

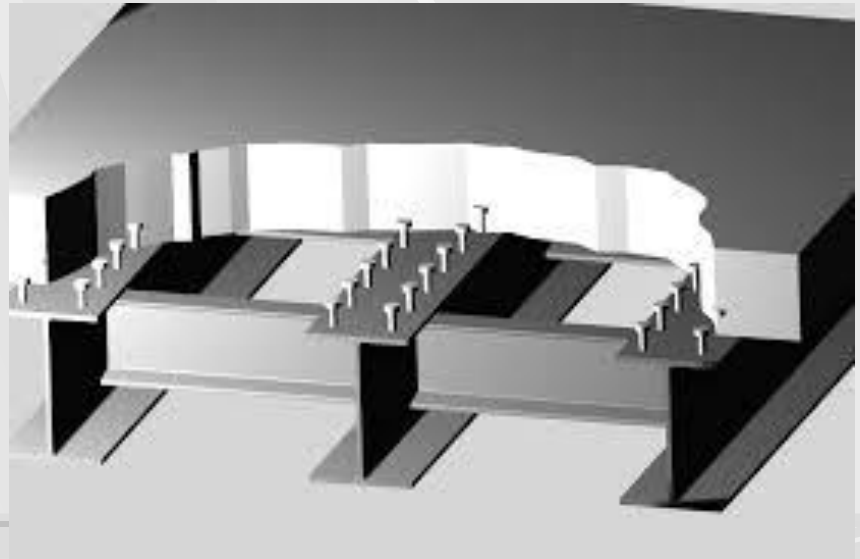
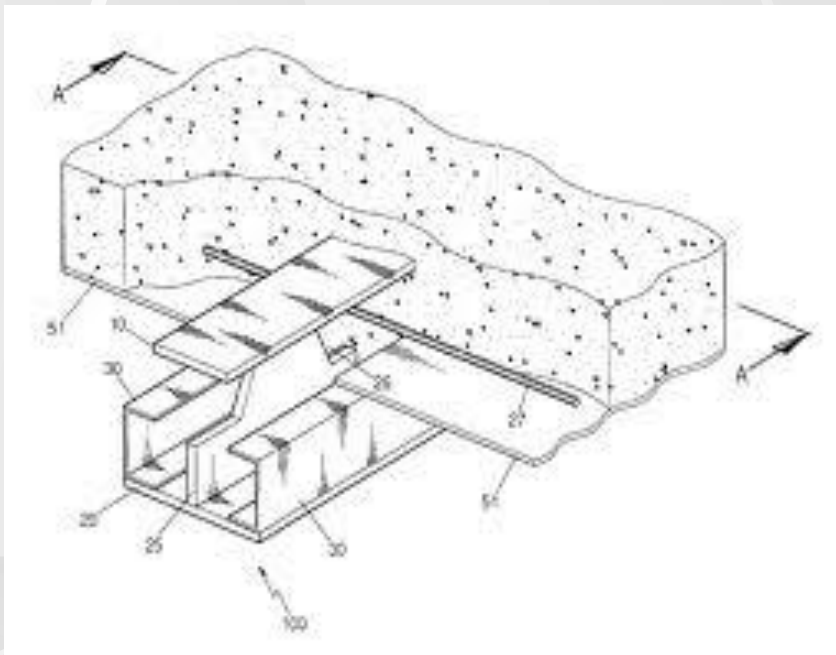


a) Top Flange of Beam Embedded in RC Slab.



b) Top Flange of Beam Connected to RC Slab By Shear Connections

Figure 4.8. Different Types of Composite Beams



# General Spans

**Table 4.2. General Span Range for Beams**

S. No.	Type of Beam	Span Range
a)	Main beams	$\leq 12$ m
b)	Secondary beams	4 – 6 m
c)	Steel joists	2 – 4 m

## Stiffeners

**a) Stiffened beam:** Stiffening plates are provided for webs, flanges, or for stability as in built-up sections.

**b) Unstiffened beam:** Beams without any additional stiffeners such as rolled steel sections alone are called unstiffened beams.

## **Stability of Section**

The beams may consist of compact, non-compact and slender sections depending on the braced length and the loading.

The flexural capacity and economy of the beam greatly depends on the stability of the section used.

## **Lateral Support**

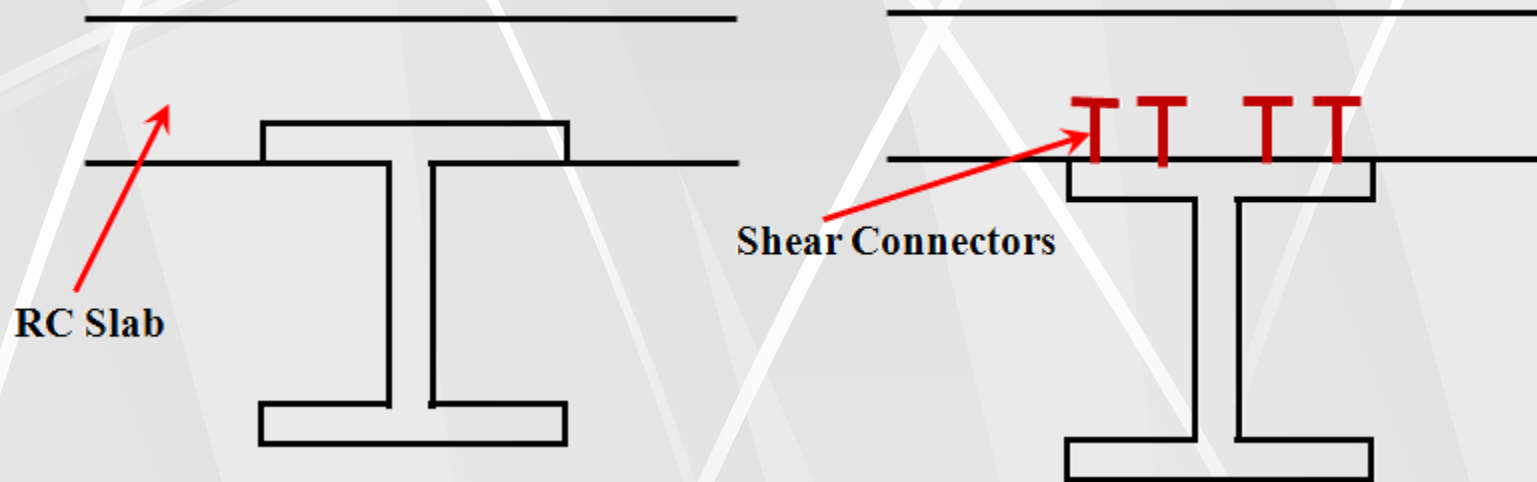
In case of a beam, lateral support is generally required to be provided for the compression flange to prevent lateral torsional buckling.

However, a full support preventing the rotation of the section is considered preferable.

The lateral support can be of the following types:

## *(a) Continuous lateral support*

In this case, compression flange is braced laterally along its entire span.



**Figure 4.9. Types of Continuous Lateral Supports**

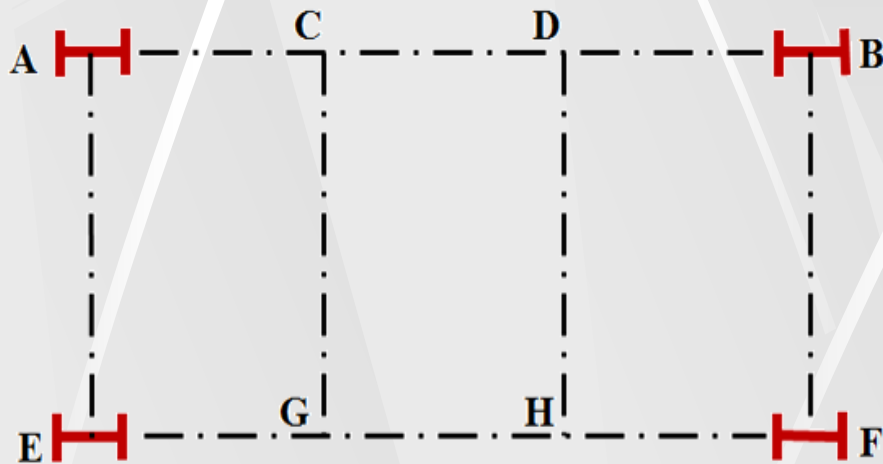
For example, as shown in Figure 4.9, if compression flange is encased in concrete slab or is connected by sufficient shear connectors with the slab, a continuous bracing is provided.

Chances of local instability of compression flange and overall lateral instability are eliminated.

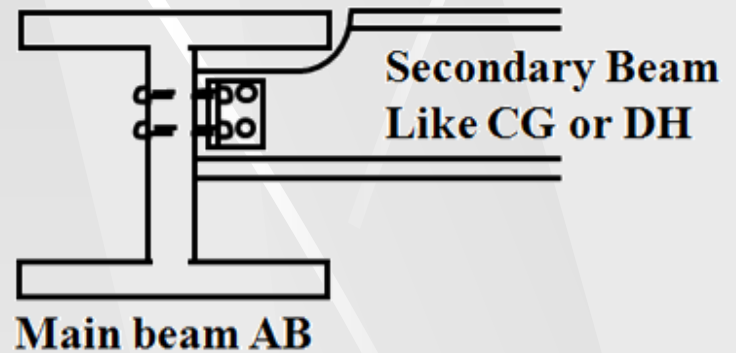
## *(b) Lateral support at intervals*

This can be provided by cross beams, cross frames, ties, or struts, framing in laterally.

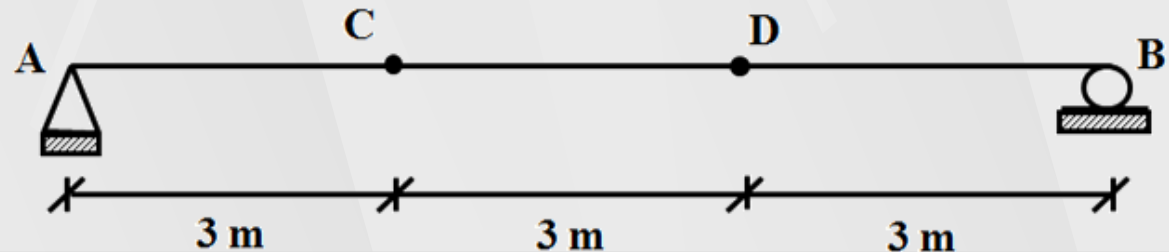
The lateral system supporting the braces should itself be adequately stiff and braced.



(a) Plan View of a Building



(b) Connection of Secondary Beam (Brace) to the Main Beam



(c) Unbraced Lengths for the Main Beam, AB

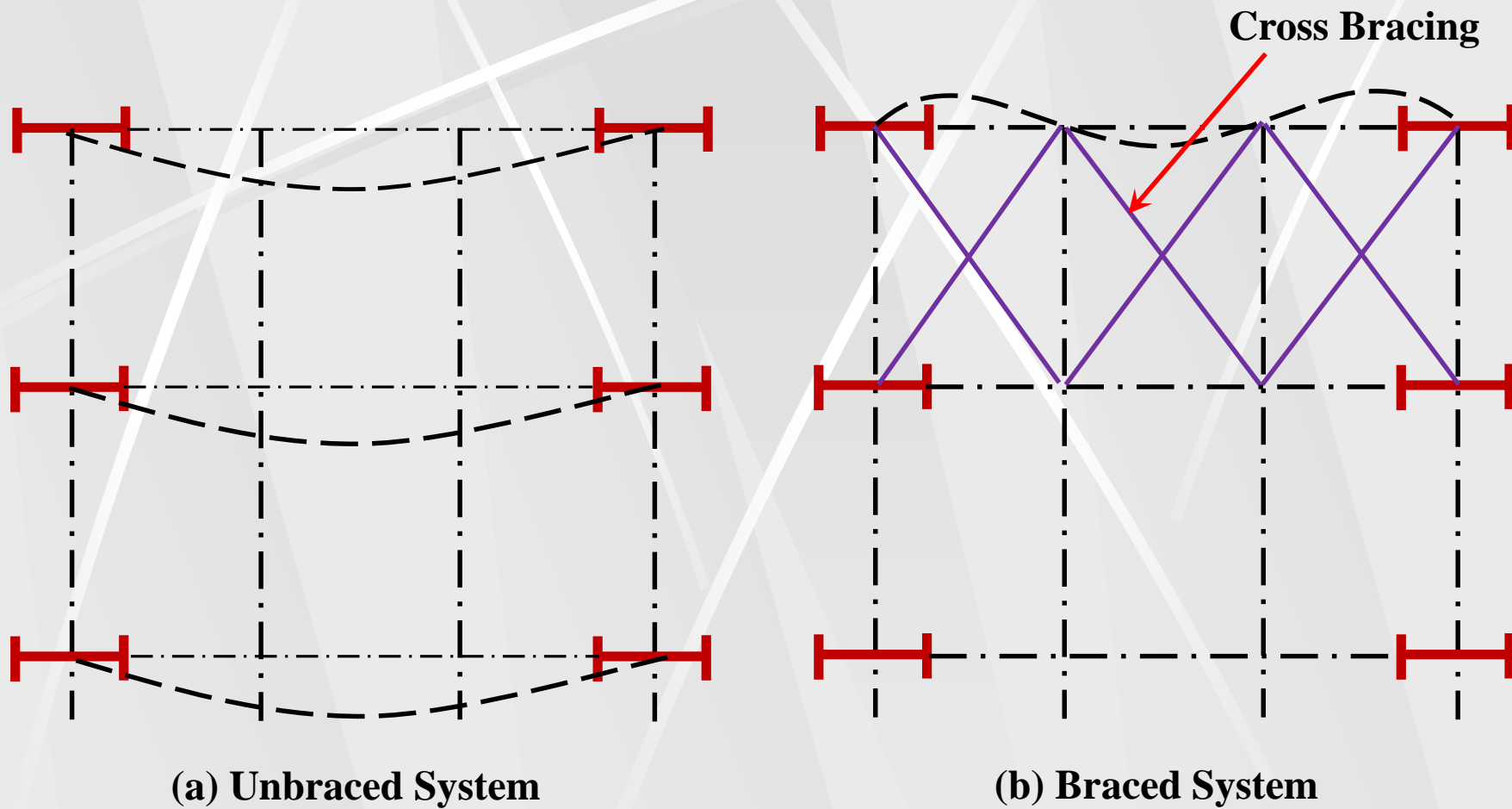
**Figure 4.10. Lateral Supports at Intervals**

While providing lateral support at intervals, it is necessary to make sure that the supporting structure itself does not buckle simultaneously.

Figure 4.11(a) represents a case in which all the main beams can buckle as a whole with unbraced length equal to their full span even if cross beams are present.

However, cross bracing is provided in Figure 4.11(b), which makes the lateral bracing effective.

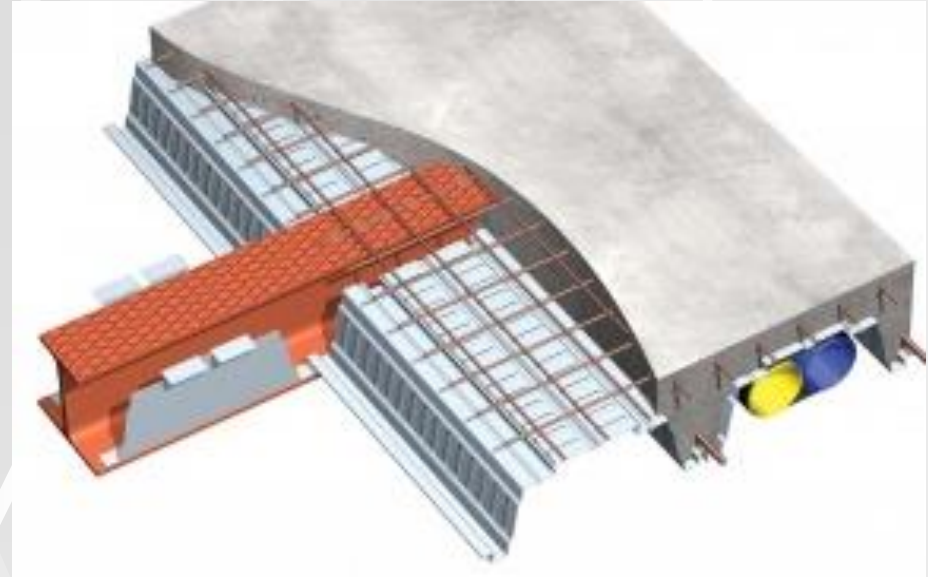
The system of cross bracing provided in one of the bays will act as sufficient lateral support for the beams of several bays.

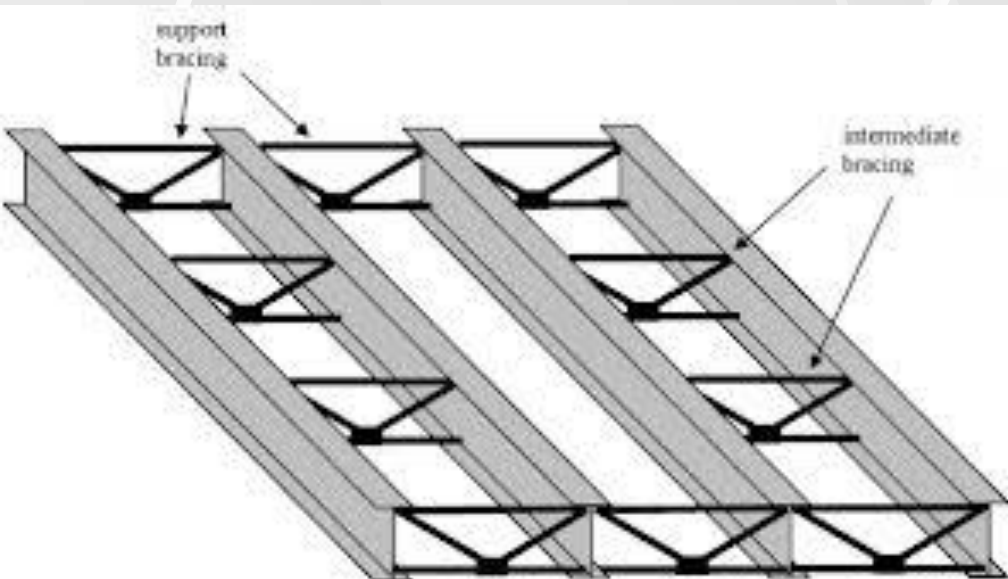


**Figure 4.11. Example of Cross Bracing**



# LATERAL BRACING FOR THE BEAM



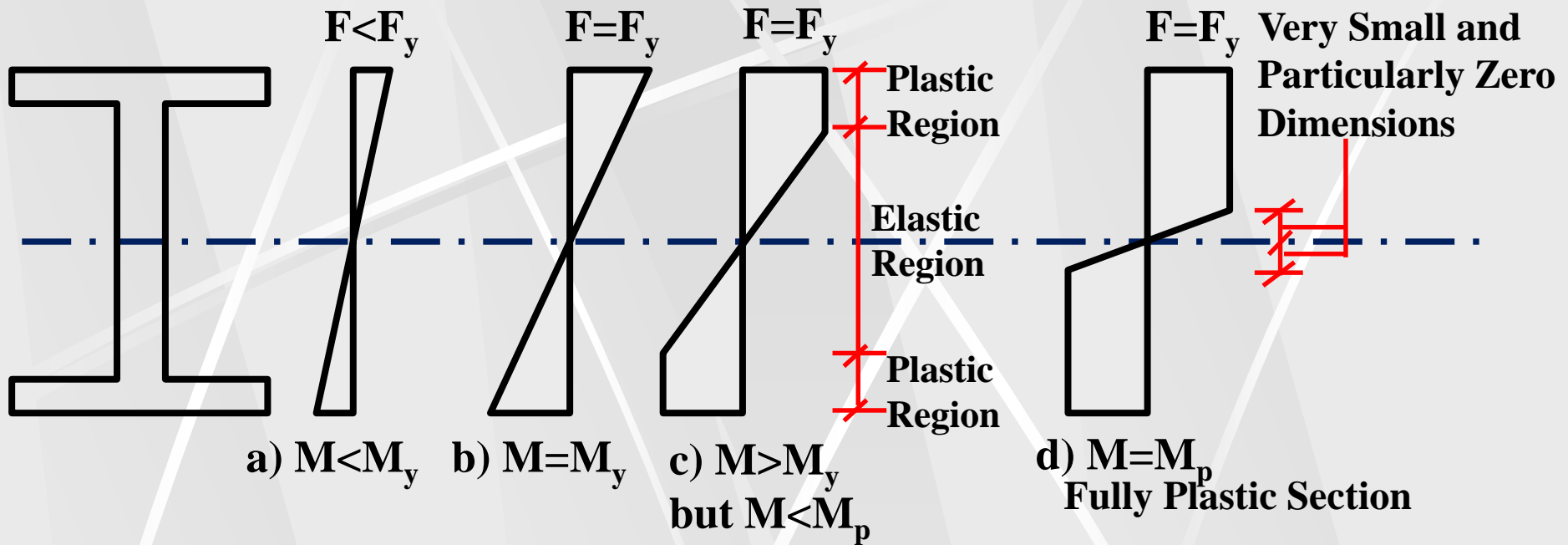


# **FLEXURAL BEHAVIOR OF COMPACT BEAMS**

When beams have adequate lateral stability of the compression flange, the only stability limit state that might limit moment strength is local buckling in compression flange and/or web plate elements making up the cross-section.

For an internally compact section, even these types of instabilities do not occur and the section may reach the limit state of yielding throughout the depth of the cross section.

The stress distribution on a typical wide-flange shape subjected to increasing bending moment is shown in Figure 4.12.



**Figure 4.12. Flexural Stresses in a Beam**

When the yield stress is reached at the extreme fibre, the nominal moment strength  $M_n$  is referred to as the yield moment  $M_y$  and is computed as

$$M_n = M_y = S_x F_y$$

When the condition of part **(d)** is reached, every fibre has a strain equal to or greater than  $\varepsilon_y = F_y / E_s$  and is in the *plastic range*.

*The nominal moment strength  $M_n$*  in this case is, therefore, referred to as the *plastic moment ( $M_p$ )*, which is computed as follows:

$$M_p = F_y \int_A y dA = F_y Z_x$$

Where  $Z_x$ , equal to  $\int y dA$ , is first moment of all the area about an axis that equally divides the area (equal area axis) and is called *plastic section modulus*.

It is observed that the ratio  $M_p / M_y$  is a property of the cross-sectional shape and is independent of the material properties.

It tells how much the moment at a section can be increased beyond first yield moment.

This ratio is referred to as the *Shape Factor* denoted by the letter *f*.

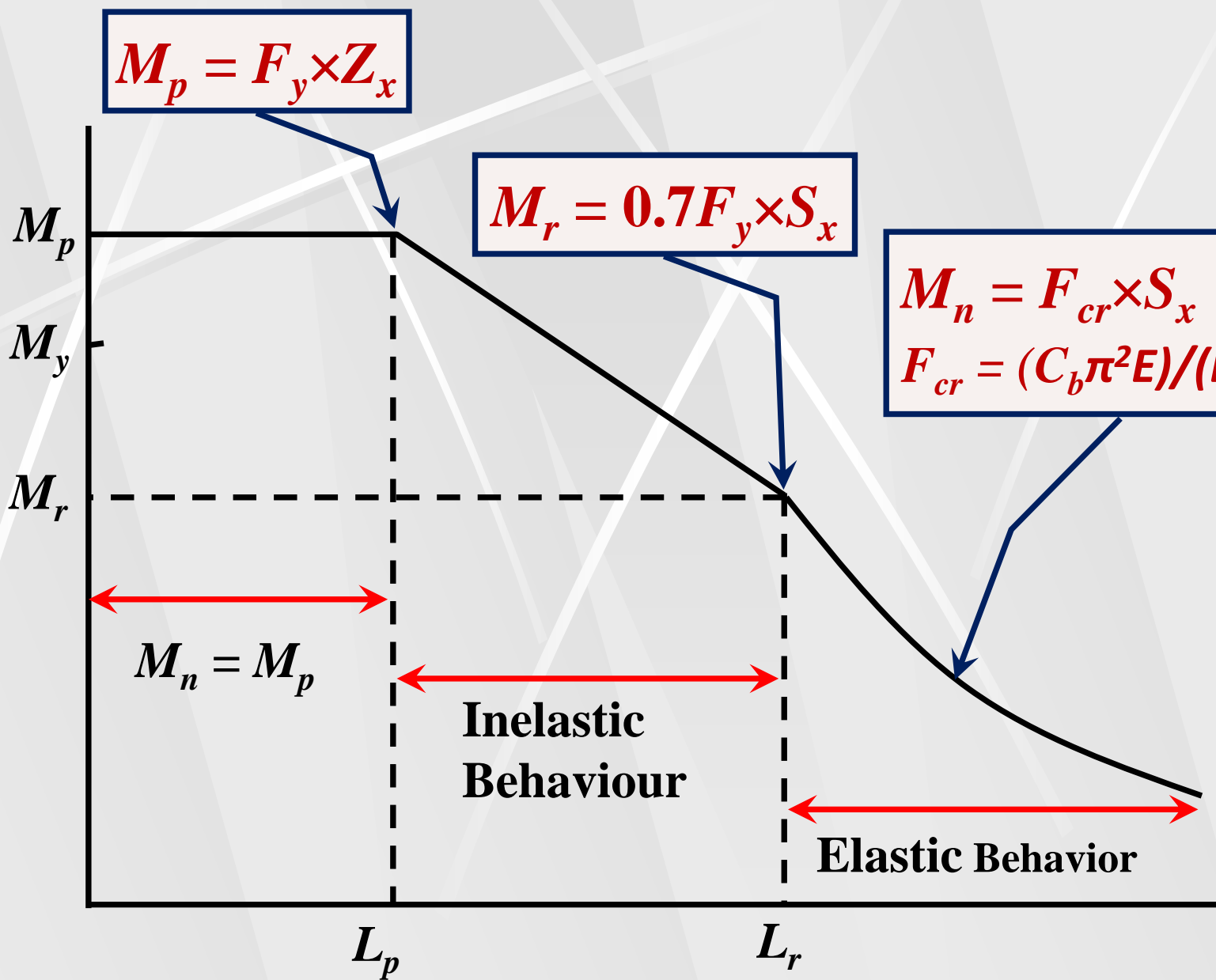
$$f = \frac{M_p}{M_y} = \frac{Z_x}{S_x}$$

Once the plastic moment strength  $M_p$  has been reached, the section can offer no additional resistance to rotation, behaving as a fictitious hinge but with constant resistive moment  $M_p$ , a condition known as a plastic hinge.

Plastic hinge acts just like a real hinge in producing instability of the structure.

In general, any combination of three hinges, real or plastic, in a span will result in an unstable condition known as a *collapse mechanism*.

Nominal Moment Strength ( $M_n$ )



$$M_p = F_y \times Z_x$$

$$M_r = 0.7 F_y \times S_x$$

$$M_n = F_{cr} \times S_x$$
$$F_{cr} = (C_b \pi^2 E) / (L_b / r_{ts})^2$$

$M_n = M_p$

Inelastic Behaviour

Elastic Behavior

Laterally Unbraced Length ( $L_b$ )

Further, the nominal flexural strength,  $M_n$ , of a beam is the lowest value obtained for the following limit states:

- a) yielding,
- b) lateral-torsional buckling,
- c) flange local buckling, and
- d) web local buckling.

## **LTB BUCKLING MODIFICATION FACTOR ( $C_b$ )**

According to AISC,  $C_b$  is the *Lateral-Torsional Buckling Modification Factor* for non-uniform moment diagrams when both ends of the unsupported segment are braced.

The factor  $C_b$  accounts for the moment gradient or the shape of the bending moment diagram.



Effect of the maximum moment present throughout the beam segment is much more severe and  $C_b = 1.0$  for this case. Greater values of  $C_b$  indicate more flexural strength.

If bending moment is lesser within the span than the ends,  $C_b$  can be taken greater than one.

Similarly, in addition to above, if reverse curvature is present, the situation becomes still less severe and value of  $C_b$  may further be increased.

### Value of $C_b$

$C_b = 1.0$  for cantilevers or overhangs with unbraced free ends.

$$C_b = \frac{12.5 M_{\max}}{2.5 M_{\max} + 3 M_A + 4 M_B + 3 M_C}$$

where  $M$  is the absolute value of a moment in the unbraced beam segment defined as follows:

$M_{\max}$  = the maximum absolute moment in the unbraced beam segment

$M_A$  = absolute moment at the quarter point of the unbraced beam segment

$M_B$  = absolute moment at the centreline of the unbraced beam segment

$M_C$  = absolute moment at the three-quarter point of the unbraced beam segment

## Unbraced Length And $C_b$ For Cantilever Beams

If no lateral brace is provided in the cantilever length.

$L_b =$  actual length and  $C_b = 1.0$ .

If lateral brace is provided at free end.

$L_b =$  actual length and  $C_b$  is calculated by the formula.

### Note:

While using the beam selection curves of *Reference-1* (Page 193-279),  $C_b$  factor may be combined with  $L_b$  and  $L_b/C_b$  value may be used as modified unbraced values

# FLEXURAL STRENGTH OF BEAMS

For a safe beam, the applied moment (service moment  $M_a$  in ASD and factored moment  $M_u$  in LRFD) must be lesser than or equal to the design strength of the beam.

$$M_u \leq \phi_b M_n \quad \phi_b = 0.90 \quad (\text{LRFD})$$

$$M_a \leq M_n / \Omega_b \quad \Omega_b = 1.67 \quad (\text{ASD})$$

where  $M_n$  = nominal flexural strength as determined by the limit state of yielding, lateral torsional buckling, or local buckling.

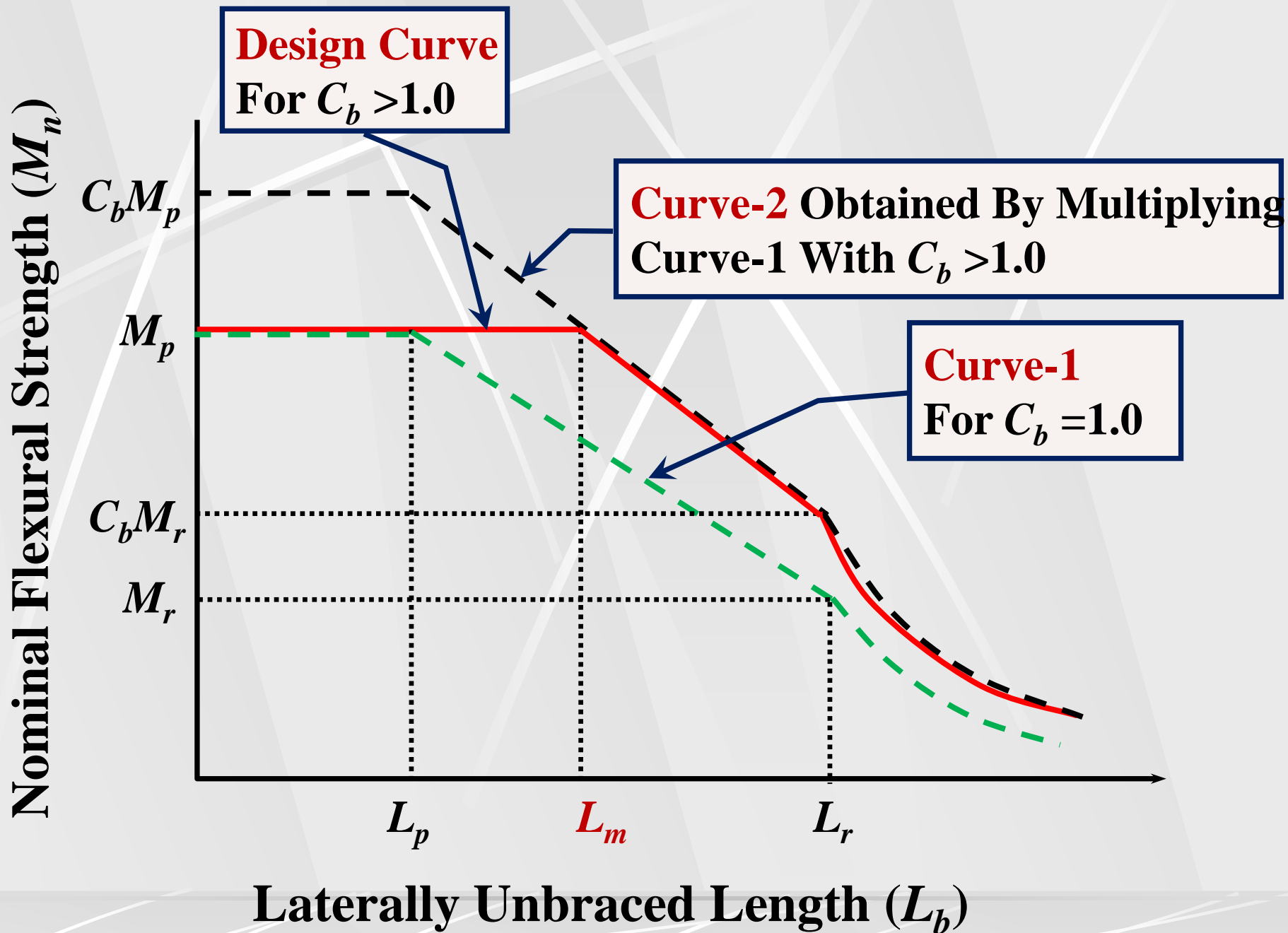
To graphically show the effect of a value of  $C_b$  greater than one on the design flexural strength of a beam, the curve of Figure 4.13 is multiplied with  $C_b = 1.0$  and is reproduced in Figure 4.14 as **Curve-1**.

The flexural capacity is increased by multiplying with  $C_b$  (greater than one) and is presented as **Curve-2**.

However, the flexural capacity of any section cannot be greater than the full plastic moment capacity. Applying this condition, **Curve-2** is changed into the applicable curve shown by solid line in the figure.

A new value of limiting unbraced length denoted by  $L_m$  is to be defined in place of  $L_p$  as follows:

$L_m$  = limiting unbraced length for full plastic bending capacity when  $C_b > 1.0$  which is between the lengths  $L_p$  and  $L_r$ .



This length  $L_m$  may be calculated by using the following expression:

$$\begin{aligned}L_m &= L_p + \frac{(C_b M_p - M_p)(L_r - L_p)}{C_b (M_p - M_r)} \\&= L_p + \frac{(C_b M_p - M_p)}{C_b \times BF} \\&= L_p + \frac{M_p}{BF} \left( \frac{C_b - 1}{C_b} \right) \leq L_r\end{aligned}$$

**$BF$**  = slope of moment capacity versus unbraced length for inelastic lateral torsional buckling.

$$BF = \frac{M_p - M_r}{L_r - L_p}$$

When  $C_b = 1.0$ ,  $L_m = L_p$

Design moment capacity ( $M_n$ ) is determined for various cases of unbraced lengths as follows:

**Case I:** Compact Sections,  $C_b \geq 1.0$ ,  $L_b \leq L_m$

$$M_n = M_p = Z_x F_y / 10^6 \text{ (kN-m)}$$

**Case II:** Compact Sections,  $C_b \geq 1.0$ ,  $L_m < L_b \leq L_r$

$$M_n = C_b \left[ M_p - (M_p - M_r) \left( \frac{L_b - L_p}{L_r - L_p} \right) \right] \leq M_p, \text{ (kN-m)}$$

$$M_n = C_b [M_p - BF(L_b - L_p)] \leq M_p \text{ (kN-m)}$$

**Case III:** Compact Sections,  $C_b \geq 1.0$ ,  $L_b > L_r$

For doubly symmetric I-shaped and channel section members:

$$M_n = C_b F_{cr} S_x \leq M_p \text{ (kN-m)}$$



Where

$$F_{cr} = \frac{C_b \pi^2 E}{\left(\frac{L_b}{r_{ts}}\right)^2} \sqrt{1 + 0.078 \frac{J c}{S_x h_o} \left(\frac{L_b}{r_{ts}}\right)^2} \approx \frac{C_b \pi^2 E}{\left(\frac{L_b}{r_{ts}}\right)^2}$$

The variables  $r_{ts}$  and others are as defined earlier. *The square root term may conservative be taken equal to 1.0.*

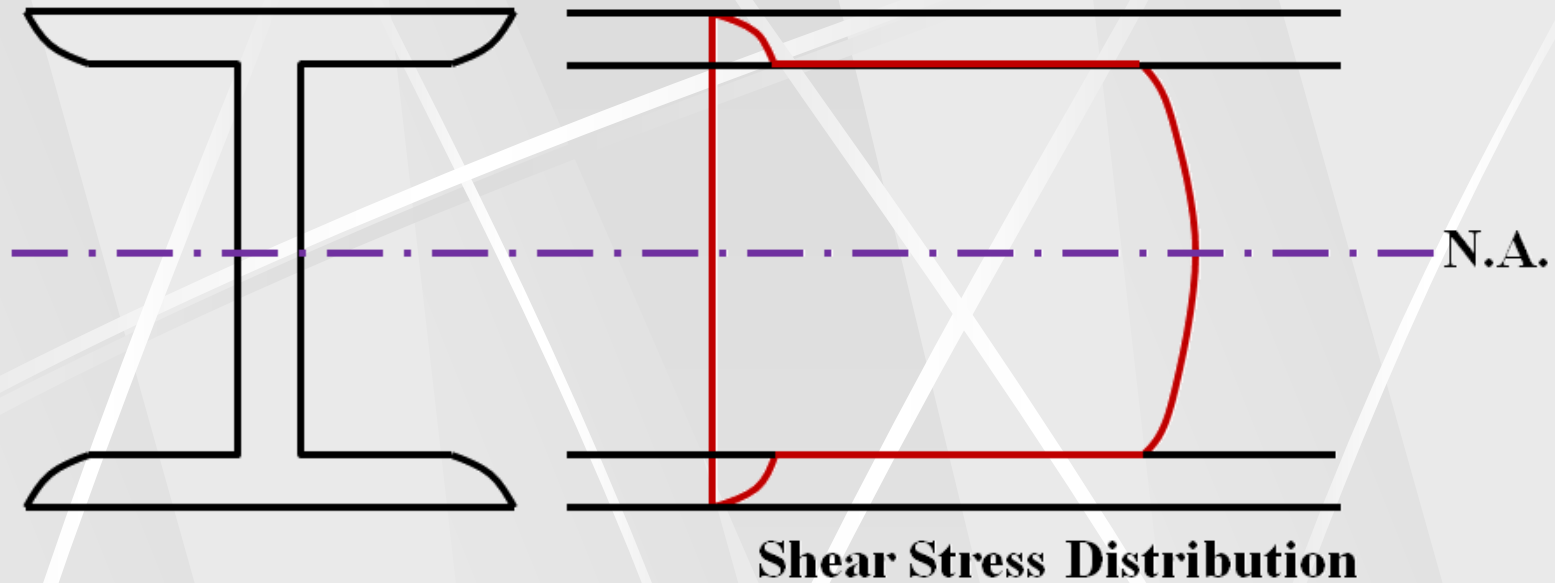
## DESIGN SHEAR STRENGTH

In case of beams, the shear stress distribution creates negligibly less stresses in the flanges and only web resists most of the applied shear.

This fact is schematically shown in Figure 4.15.

Hence, the area resisting shear is equal to area of web as under:

$$A_w = d \times t_w$$



**Figure 4.15. Shear Stress Distribution in An I-Section Beam.**

The stable web of a beam may reach its limit by web yielding, in which yielding in shear takes place when the applied shear stress ( $\tau$ ) becomes equal to shear yield stress ( $\tau_y$ ).

For ductile materials, shear yield stress is approximately equal to 60 percent of the tension yield stress ( $0.6 F_y$ ).

The factor 0.6 is not a factor of safety but is a factor to approximately change principal tensile stress into shear stress at maximum shear stress plane or vice versa.

The design shear strength of webs is  $\phi_v V_n$  with  $\phi_v = 0.90$  (LRFD) and the allowable shear strength is  $V_n / \Omega_v$  with  $\Omega_v = 1.67$  (ASD).

For webs of rolled I-shaped members:

$$V_n = 0.6F_y A_w C_v$$

**Web Yielding:**

$$\text{For } \frac{h}{t_w} \leq 2.24 \sqrt{E / F_{yw}}$$

$$(\text{= } 63.4 \text{ for A36 steel}) \quad : \quad C_v = 1.0$$

**Note:**

- 1) Average applied shear stress,  $f_v = \frac{V_u}{dt_w}$  (LRFD)
- 2) Beam is safe in shear when  $V_u \leq \phi_v V_n$  (LRFD)

## DEFLECTIONS

Deflection check is a ***serviceability limit state check*** and hence, it is applied using the service loads and not the factored loads.

Further, for steel structures, this check is usually applied only using the service live load and the deflection due to dead loads are not considered.

The reason for not including the dead load in the calculation of deflections is that the structure is given a negative camber during construction to balance the dead load deflections.

There are several justifications for limiting service live load deflections, some of which are as under:

1. The deflections produced should not be visible to the people. It is important to remember that some deflection always occur which can be measured by instruments. Common people may consider a structure that is completely safe from strength point of view unsafe and dangerous if the deflections are larger.

2. The appearance of structures may be damaged by excessive deflections such as the plaster may crack and other surface finishes may be disturbed.
3. Excessive deflections in a member may damage other members attached to it. For example, deflections produced in a main beam may cause high extra stresses in the secondary beams and roofing resting on it.
4. In case the structure is supporting any type of machinery, the deflection of one part may disturb the alignment of the machinery shafts.
5. Sometimes, it may be required that different parts of structure deflect by same amount when symmetric loads are applied on them.

- In case of buildings, the maximum service live load deflection is usually limited to  **$L/360$** . This limit is considered invisible not damaging the surface finishes.
- The deflections may be limited to  **$L/1500$**  or  **$L/2000$**  for structures supporting delicate machinery.
- In case of bridge, deflections due to live and impact loads are restricted to  **$L/800$** .
- During initial proportioning of steel beams, it is customary to indirectly control deflections by limiting the span-over-depth ratio ( **$L/d$  ratio**) for the members. When these conditions are satisfied it is more likely that the deflection check, to be performed later on, will be satisfied eliminating the need for greater number of trials to get a reasonable section.

Typical span-over-depth ratios used for various types of members are as under:

- 1- For buildings,  $L/d$  ratio is usually limited to a maximum of  $5500 / F_y$ .

$$L/d \leq 5500 / F_y$$

$$\therefore d_{min} = F_y L / 5500 \text{ (} L/22 \text{ for A36 steel)}$$

- 2- For bridge components and other beams subjected to impact or vibratory loads,

$$L/d \leq 20$$

- 3- For roof purlins,

$$L/d \leq 6900 / F_y \text{ (} 27.5 \text{ for A36 steel, sometimes relaxed to a value equal to 30)}$$



The actual expected deflections may be calculated using the mechanics principles.

However, results given in Manuals and Handbooks may also be used directly.

Some of the typical deflection formulas are reproduced here.

1- For uniformly loaded and simply supported beams

$$\Delta_{\max} = \frac{5w_L L^4}{384 EI}$$

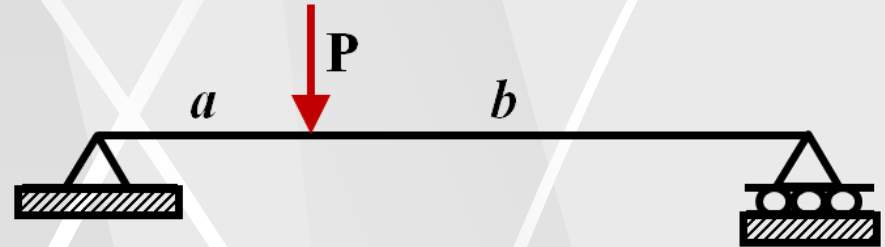
2- For uniformly loaded continuous beams

$$\Delta_{\text{midspan}} = \frac{5L^2}{48 EI} [M_c - 0.1(M_a + M_b)]$$

Where  $M_c$  = magnitude of central moment  
 $M_a, M_b$  = magnitude of end moments

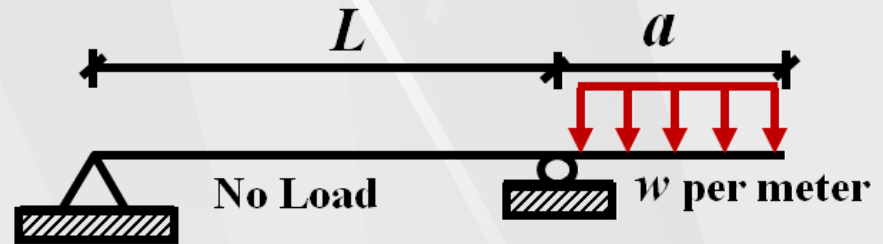
- 3- For simply supported beams subjected to point load (refer to Figure 4.16), where  $a \leq L/2$

$$\Delta_{midspan} = \frac{Pa}{12EI} \left( \frac{3}{4}L^2 - a^2 \right)$$



- 4- For overhanging part of beam subjected to UDL

$$\Delta_{max} \cong \frac{wa^3}{24EI} (4L + 3a)$$



- 5- For the above case, with UDL also present within supports,

$$\Delta_{max} \cong \frac{wa}{24EI} (4a^2L - L^3 + 3a^3)$$

6- For overhanging part of beam subjected to point load

$$\Delta_{\max} = \frac{P a^2 (L + a)}{3EI}$$



7- For cantilever beam subjected to point load  $P$  at distance  $a$  from the fix end

$$\Delta_{\max} = \frac{P a^2 (3L - a)}{6EI}$$

8- For cantilever beam subjected to a uniformly distributed load

$$\Delta_{\max} = \frac{w L^4}{8EI}$$