

## **Module 8 : Sewer Appurtenances**

### **Lecture 10 : Sewer Appurtenances**

The structures, which are constructed at suitable intervals along the sewerage system to help its efficient operation and maintenance, are called as sewer appurtenances. These include:

- (1) Manholes,                      (2) Drop manholes,                      (3) Lamp holes,
- (4) Clean-outs,                      (5) Street inlets called Gullies,                      (6) Catch basins,
- (7) Flushing Tanks,                      (8) Grease & Oil traps,                      (9) Inverted Siphons, and
- (10) Storm Regulators.

### 8.1 Manholes

The manhole is masonry or R.C.C. chamber constructed at suitable intervals along the sewer lines, for providing access into them. Thus, the manhole helps in inspection, cleaning and maintenance of sewer. These are provided at every bend, junction, change of gradient or change of diameter of the sewer. The sewer line between the two manholes is laid straight with even gradient. For straight sewer line manholes are provided at regular interval depending upon the diameter of the sewer. The spacing of manhole is recommended in IS 1742-1960. For sewer up to 0.3 m diameter or sewers which cannot be entered for cleaning or inspection the maximum spacing between the manholes recommended is 30 m, and 300 m spacing for pipe greater than 2.0 m diameter (Table 8.1). A spacing allowance of 100 m per 1 m diameter of sewer is a general rule in case of very large sewers (CPHEEO, 1993). The internal dimensions required for the manholes are provided in Table 8.2 (CPHEEO, 1993). The minimum width of the manhole should not be less than internal diameter of the sewer pipe plus 150 mm benching on both the sides.

**Table 8.1** Spacing of Manholes

Pipe Diameter	Spacing
Small sewers	45 m
0.9 to 1.5 m	90 to 150 m
1.5 to 2.0 m	150 to 200 m
Greater than 2.0 m	300 m

**Table 8.2** The minimum internal dimensions for manhole chambers

Depth of sewer	Internal dimensions
0.9 m or less depth	0.90 m x 0.80 m
For depth between 0.9 m and 2.5 m	1.20 m x 0.90 m, 1.2 m dia. for circular
For depth above 2.5 m and up to 9.0 m	For circular chamber 1.5 m dia.
For depth above 9.0 m and up to 14.0 m	For circular chamber 1.8 m dia.

### 8.1.1 Classification of Manholes

Depending upon the depth the manholes can be classified as:

(a) Shallow Manholes, (b) Normal Manholes, and (c) Deep Manholes

**Shallow Manholes:** These are 0.7 to 0.9 m depth, constructed at the start of the branch sewer or at a place not subjected to heavy traffic conditions (Figure 8.1). These are provided with light cover at top and called inspection chamber.

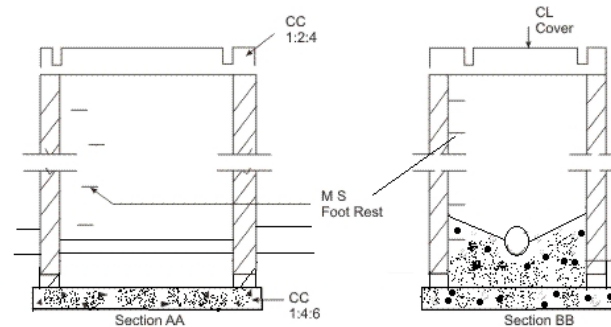

Figure 8.1 Shallow manhole

**Normal Manholes:** These manholes are 1.5 m deep with dimensions 1.0 m x 1.0 m square or rectangular with 1.2 m x 0.9 m (Figure 8.2). These are provided with heavy cover at its top to support the anticipated traffic load.

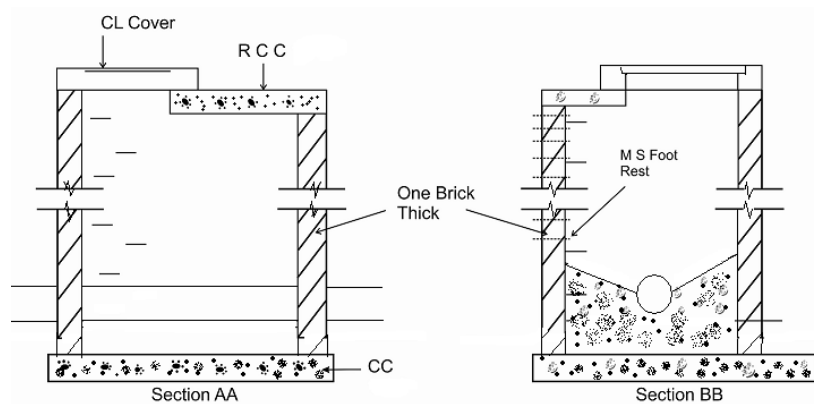
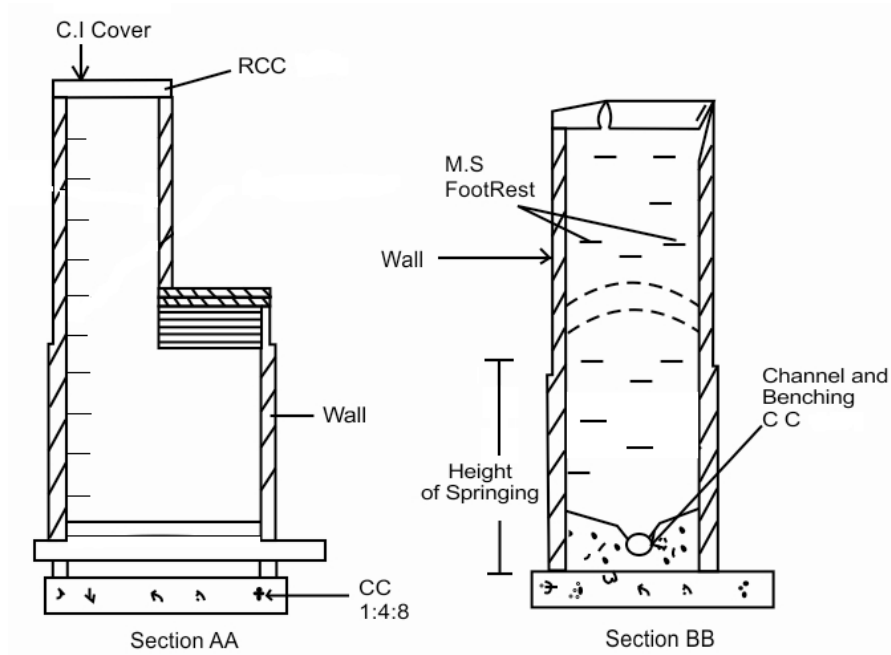
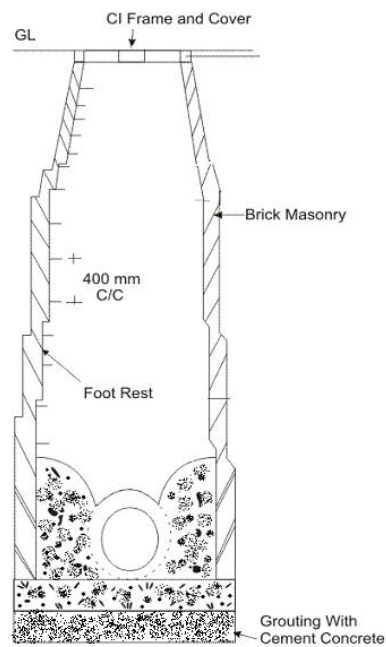

Figure 8.2 Rectangular manhole for depth 0.9 m to 2.5 m

**Deep Manholes:** The depth of these manholes is more than 1.5 m. The section of such manhole is not uniform throughout (Figure 8.3). The size in upper portion is reduced by providing an offset. Steps are provided in such manholes for descending into the manhole. These are provided with heavy cover at its top to support the traffic load.



(a)



(b)

Figure 8.3 (a) Rectangular and (b) Circular deep manhole

### 8.1.2 Other Types of Manholes

#### **Straight – Through Manholes**

This is the simplest type of manhole, which is built on a straight run of sewer with no side junctions. Where there is change in the size of sewer, the soffit or crown level of the two sewers should be the same, except where special conditions require otherwise.

***Junction Manholes***

This type of manholes are constructed at every junction of two or more sewers, and on the curved portion of the sewers, with curved portion situated within the manhole. This type of manholes can be constructed with the shape other than rectangular to suit the curve requirement and achieve economy. The soffit of the smaller sewer at junction should not be lower than that of the larger sewer. The gradient of the smaller sewer may be made steeper from the previous manhole to reduce the difference of invert at the point of junction to a convenient amount.

***Side entrance Manholes***

In large sewers where it is difficult to obtain direct vertical access to the sewer from the top ground level due to obstructions such as, other pipe lines like water, gas, etc., the access shaft should be constructed in the nearest convenient position off the line of sewer, and connected to the manhole chamber by a lateral passage. The floor of the side entrance passage which should fall at about 1 in 30 towards the sewer should enter the chamber not lower than the soffit level of the sewer. In large sewers necessary steps or a ladder (with safety chain or removable handrail) should be provided to reach the benching from the side entrance above the soffit.

***Drop Manholes***

When a sewer connects with another sewer, where the difference in level between invert level of branch sewer and water line in the main sewer at maximum discharge is greater than 0.6 m, a manhole may be built either with vertical or nearly vertical drop pipe from higher sewer to the lower one (Figure 8.4). The drop manhole is also required in the same sewer line in sloping ground, when drop more than 0.6 m is required to control the gradient and to satisfy the maximum velocity i.e., non-scouring velocity.

The drop pipe may be outside the shaft and encased in concrete or supported on brackets inside the shaft. If the drop pipe is outside the shaft, a continuation of the sewer should be built through the shaft wall to form a rodding and inspection eye, provided with half blank flange (Figure 8.4). When the drop pipe is inside the shaft, it should be of cast iron and provided with adequate arrangements for rodding and with water cushion of 150 mm depth at the end. The diameter of the drop pipe should be at least equal to incoming pipe.

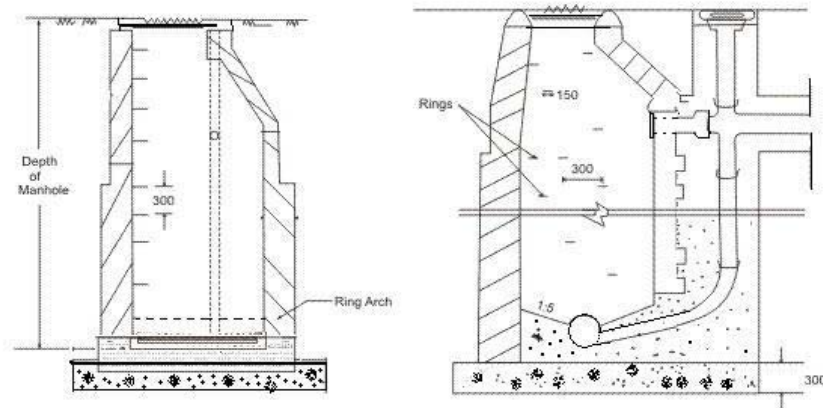

Figure 8.4 Drop manhole

### ***Scraper (service) type manhole***

All sewers above 450 mm in diameter should have one manhole at intervals of 110 to 120 m of scraper type. This manhole should have clear opening of 1.2 m x 0.9 m at the top to facilitate lowering of buckets.

### ***Flushing Manholes***

In flat ground for branch sewers, when it is not possible to obtain self cleansing velocity at all flows, due to very little flow, it is necessary to incorporate flushing device. This is achieved by making grooves at intervals of 45 to 50 m in the main drains in which wooden planks are inserted and water is allowed to head up. When the planks are removed, the water will rush with high velocity facilitating cleaning of the sewers. Alternatively, flushing can be carried out by using water from overhead water tank through pipes and flushing hydrants or through fire hydrants or tankers and hose.

Flushing manholes are provided at the head of the sewers. Sufficient velocity shall be imparted in the sewer to wash away the deposited solids. In case of heavy chocking in sewers, care should be exercised to ensure that there is no possibility of back flow of sewage into the water supply mains.

## **8.2 INVERTED SIPHONS**

An inverted siphon or depressed sewer is a sewer that runs full under gravity flow at a pressure above atmosphere in the sewer. Inverted siphons are used to pass under obstacles such as buried pipes, subways, etc (Fig. 8.5). This terminology 'siphon' is misnomer as there

is no siphon action in the depressed sewer. As the inverted siphon requires considerable attention for maintenance, it should be used only where other means of passing an obstacle in line of the sewer are impracticable.

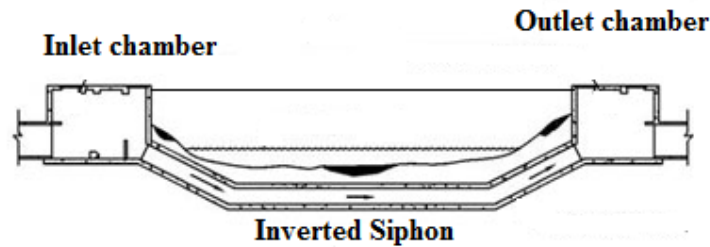

Figure 8.5 Inverted siphon

### 8.3 STORMWATER INLETS

Storm water inlets are provided to admit the surface runoff to the sewers. These are classified in three major groups viz. curb inlets, gutter inlets, and combined inlets. They are provided either depressed or flush with respect to the elevation of the pavement surface. The structure of the inlet is constructed with brickwork with cast iron grating at the opening conforming to IS 5961. Where the traffic load is not expected, fabricated steel grating can be used. The clear opening shall not be more than 25 mm. The connecting pipe from the street inlet to the sewer should be minimum of 200 mm diameter and laid with sufficient slope. A maximum spacing of 30 m is recommended between the inlets, which depends upon the road surface, size and type of inlet and rainfall.

**Curb Inlet:** These are vertical opening in the road curbs through which stormwater flow enters the stormwater drains. These are preferred where heavy traffic is anticipated (Figure 8.6a).

**Gutter Inlets:** These are horizontal openings in the gutter which is covered by one or more grating through which stormwater is admitted (Figure 8.6b).

**Combined Inlets:** In this, the curb and gutter inlet both are provided to act as a single unit. The gutter inlet is normally placed right in front of the curb inlets.

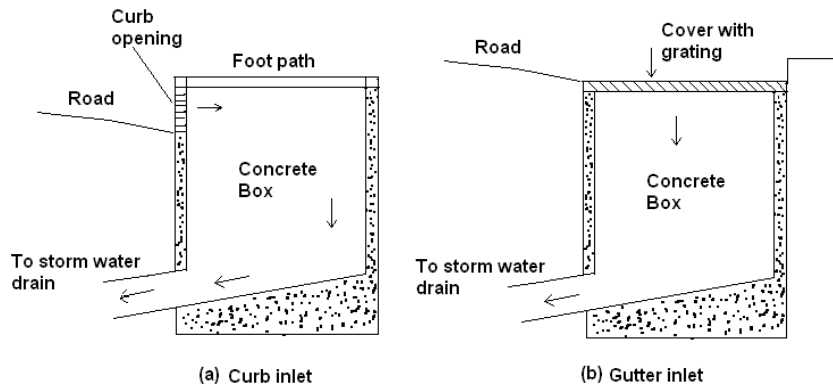

Figure 8.6 (a) Curb inlet and (b) Gutter inlet

#### 8.4 CATCH BASINS

Catch basins are provided to stop the entry of heavy debris present in the storm water into the sewers. However, their use is discouraged because of the nuisance due to mosquito breeding apart from posing substantial maintenance problems. At the bottom of the basin space is provided for the accumulation of impurities. Perforated cover is provided at the top of the basin to admit rain water into the basin. A hood is provided to prevent escape of sewer gas (Figure 8.7).

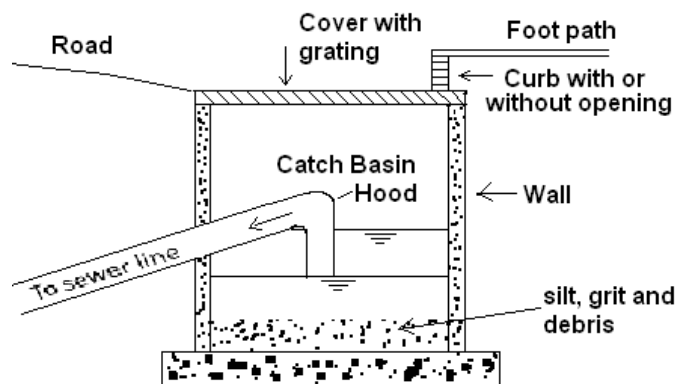

Figure 8.7 Catch basin

#### 8.5 CLEAN-OUTS

It is a pipe which is connected to the underground sewer. The other end of the clean-out pipe is brought up to ground level and a cover is placed at ground level (Figure 8.8). A clean-out is generally provided at the upper end of lateral sewers in place of manholes. During blockage of pipe, the cover is taken out and water is forced through the clean-out pipe to lateral sewers to remove obstacles in the sewer line. For large obstacles, flexible rod may be



inserted through the clean-out pipe and moved forward and backward to remove such obstacle.

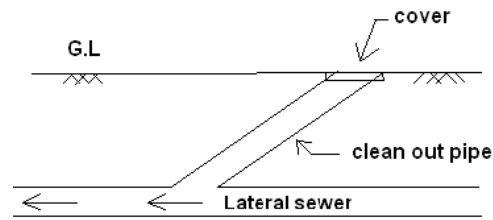

Figure 8.8 Clean-out

## 8.6 REGULATOR OR OVERFLOW DEVICE

These are used for preventing overloading of sewers, pumping stations, treatment plants or disposal arrangement, by diverting the excess flow to relief sewer. The overflow device may be side flow or leaping weirs according to the position of the weir, siphon spillways or float actuated gates and valves.

### 8.6.1 Side Flow Weir

It is constructed along one or both sides of the combined sewer and delivers the excess flow during storm period to relief sewers or natural drainage courses (Figure 8.9). The crest of the weir is set at an elevation corresponding to the desired depth of flow in the sewer. The weir length must be sufficient long for effective regulation of the flow.

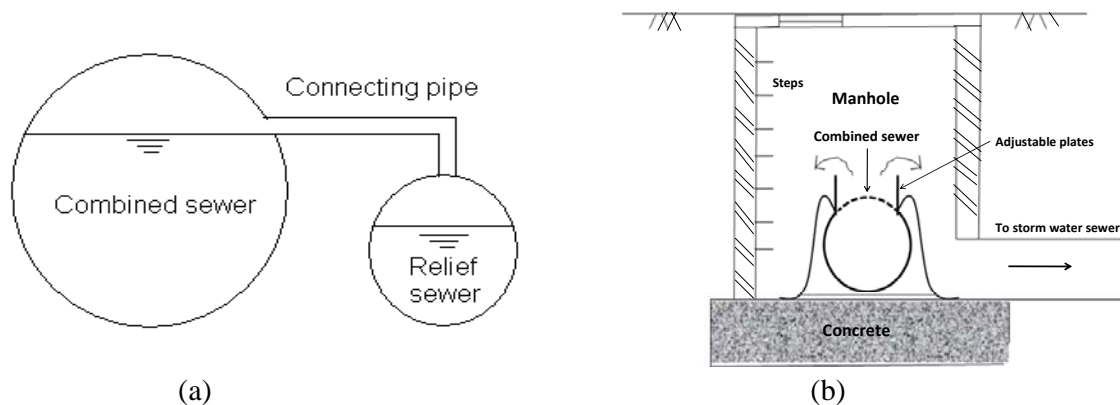

Figure 8.9 (a) Side flow weir (b) Overflow weir arrangement

### 8.6.2 Leaping Weir

The term leaping weir is used to indicate the gap or opening in the invert of a combined sewer. The leaping weir is formed by a gap in the invert of a sewer through which the dry weather flow falls and over which a portion of the entire storm leaps. This has an advantage

of operating as regulator without involving moving parts. However, the disadvantage of this weir is that, the grit material gets concentrated in the lower flow channel. From practical consideration, it is desirable to have moving crests to make the opening adjustable. When discharge is small, the sewage falls directly into the intercepting sewer through the opening. But when the discharge exceeds a certain limit, the excess sewage leaps or jumps across the weir and it is carried to natural stream or river. This arrangement is shown in the Figure 8.10.

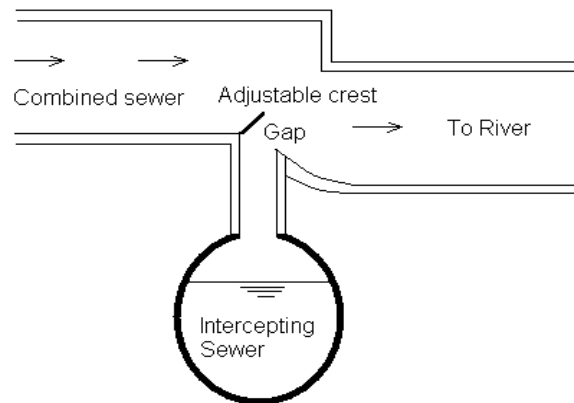

Figure 8.10 Leaping weir with adjustable crest

### 8.6.3 Float Actuated Gates and Valves

The excess flow in the sewer can also be regulated by means of automatic mechanical regulators. These are actuated by the float according to the water level in the sump interconnected to the sewers. Since, moving part is involved in this, regular maintenance of this regulator is essential.

### 8.6.4 Siphon Spillway

This arrangement of diverting excess sewage from the combined sewer is most effective because it works on the principle of siphon action and it operates automatically. The overflow channel is connected to the combined sewer through the siphon. An air pipe is provided at the crest level of siphon to activate the siphon when water will reach in the combined sewer at stipulated level (Figure 8.11).

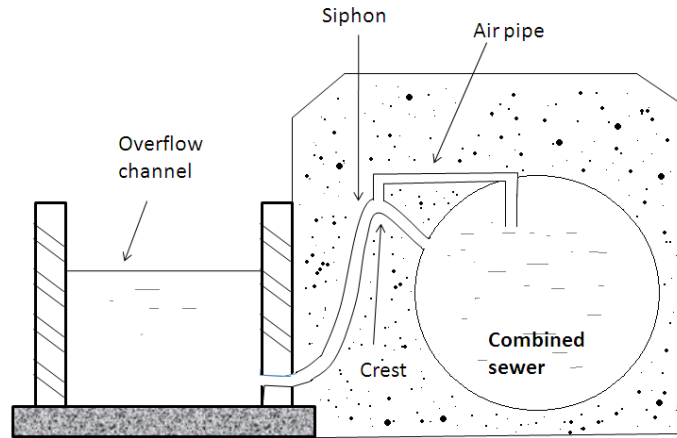

Figure 8.11 Siphon spillway

### 8.7 FLAP GATES AND FLOOD GATES

Flap gates or backwater gates are installed at or near sewer outlets to prevent back flow of water during high tide, or at high stages in the receiving stream. These gates can be rectangular or circular in shape and made up of wooden planks or metal alloy sheets. Such gates should be designed such that the flap should get open at a very small head difference. Adequate storage in outfall sewer is also necessary to prevent back flow into the system due to the closure of these gates at the time of high tides, if pumping is to be avoided.

### 8.8 SEWER VENTILATORS

Ventilation to the sewer is necessary to make provision for the escape of air to take care of the exigencies of full flow and to keep the sewage as fresh as possible. In case of stormwater, this can be done by providing ventilating manhole covers. In modern sewerage system, provision of ventilators is not necessary due to elimination of intercepting traps in the house connections allowing ventilation.

### 8.9 LAMP HOLE

It is an opening or hole constructed in a sewer for purpose of lowering a lamp inside it. It consists of stoneware or concrete pipe, which is connected to sewer line through a T-junction as shown in the Figure 8.12. The pipe is covered with concrete to make it stable. Manhole cover of sufficient strength is provided at ground level to take the load of traffic. An electric lamp is inserted in the lamp hole and the light of lamp is observed from manholes. If the sewer length is unobstructed, the light of lamp will be seen. It is constructed when

construction of manhole is difficult. In present practice as far as possible the use of lamp hole is avoided. This lamp hole can also be used for flushing the sewers. If the top cover is perforated it will also help in ventilating the sewer, such lamp hole is known as fresh air inlet.

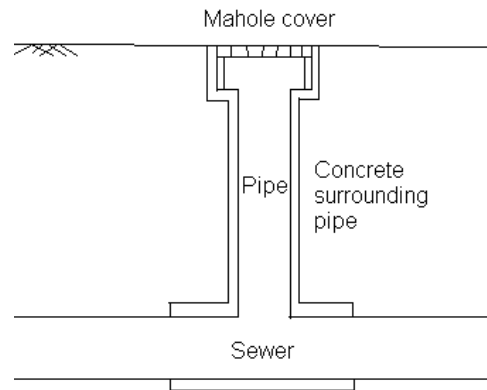

Figure 8.12 Lamp hole

### Questions

1. Define sewer appurtenances. What are the appurtenances used in sewerage?
2. Describe different types of Manholes used in collection system.
3. When the drop manhole is used in sewers?
4. Describe different types of storm water inlets used in collection system.
5. Why flow regulator device is used in sewers? Describe different types of regulators used.