

Suggested Analysis and Design Procedures for Combined Footings and Mats

Reported by ACI Committee 336

Edward J. Ulrich
Chairman

Shyam N. Shukla
Secretary

Clyde N. Baker, Jr.
Steven C. Ball
Joseph E. Bowles
Joseph P. Colaco
XI. T. Davisson

John A. Focht, Jr.
M. Gaynor
John P. Gnaedinger
Fritz Kramrisch

Hugh S. Lacy
Jim Lewis
James S. Notch
Ingvar Schousboe

John F. Seidensticker
Bruce A. Suprenant
Jagdish S. Syal
John J. Zils

This report deals with the design of foundations carrying more than a single column of wall load. These foundations are called combined footings and mats. Although it is primarily concerned with the structural aspects of the design, considerations of soil mechanics cannot be eliminated and the designer should focus on the important interrelation of the two fields in connection with the design of such structural elements. This report is limited to vertical effects of all loading conditions. The report excludes slabs on grade.

Keywords: concretes; earth pressure; footings; foundations; loads (forces); mat foundations; reinforced concrete; soil mechanics; stresses; structural analysis; structural design.

CONTENTS

Chapter 1 -General, p. 336.2R-2

- 1.1-Notation
- 1.2-Scope
- 1.3-Definitions and loadings
- 1.4-Loading combinations
- 1.5-Allowable pressure
- 1.6-Time-dependent considerations
- 1.7-Design overview

Chapter 2-Soil structure interaction, p. 336.2R-4

- 2.1-General
- 2.2-Factors to be considered
- 2.3-Investigation required to evaluate variable factors

Chapter 3-Distribution of soil reactions, p. 336.2R-6

- 3.1-General
- 3.2-Straight-line distribution
- 3.3-Distribution of soil pressure governed by modulus of subgrade reaction

Chapter 4-Combined footings, p. 336.2R-7

- 4.1-Rectangular-shaped footings
- 4.2-Trapezoidal or irregularly shaped footings
- 4.3-Overturning calculations

Chapter 5-Grid foundations and strip footings supporting more than two columns, p. 336.2R-8

- 5.1-General
- 5.2-Footings supporting rigid structures
- 5.3-Column spacing
- 5.4-Design procedure for flexible footings
- 5.5-Simplified procedure for flexible footings

Chapter 6-Mat foundations, p. 336.2R-9

- 6.1-General
- 6.2-Finite difference method
- 6.3-Finite grid method
- 6.4-Finite element method
- 6.5-Column loads
- 6.6-Symmetry
- 6.7-Node coupling of soil effects
- 6.8-Consolidation settlement
- 6.9-Edge springs for mats
- 6.10-Computer output
- 6.11-Two-dimensional or three-dimensional analysis
- 6.12--Mat thickness
- 6.13-Parametric studies
- 6.4-Mat foundation detailing/construction

Chapter 7-Summary, p. 336.2R-20

ACI Committee Reports, Guides, Standard Practices, and Commentaries are intended for guidance in designing, planning, executing, or inspecting construction and in preparing specifications. Reference to these documents shall not be made in the Project Documents. If items found in these documents are desired to be part of the Project Documents they should be phrased in mandatory language and incorporated into the Project Documents.

This report supercedes ACI 336.2R-66 (Reapproved 1980).

Copyright © 2002, American Concrete Institute.
All rights reserved including rights of reproduction and use in any form or by any means, including the making of copies by any photo process, or by any electronic or mechanical device, printed, written, or oral, or recording for sound or visual reproduction or for use in any knowledge or retrieval system or device, unless permission in writing is obtained from the copyright proprietors.

Chapter 8-References, p. 336.2R-21

- 8.1 -Specified and/or recommended references
8.2-Cited references

CHAPTER 1-GENERAL

1.1-Notation

The following dimensioning notation is used: F = force; ℓ = length; Q = dimensionless.

- A = base area of footing, ℓ^2
 b = width of pressed edge, ℓ
 B = foundation width, or width of beam column element, 4
 B_m = mat width, ℓ
 B_p = plate width, ℓ
 c = distance from resultant of vertical forces to overturning edge of the base, ℓ
 D = dead load or related internal moments and forces, F
 D_o = dead load for overturning calculations, F
 D_f = the depth D_f should be the depth of soil measured adjacent to the pressed edge of the combined footing or mat at the time the loads being considered are applied
 D_{st} = stage dead load consisting of the unfactored dead load of the structure and foundation at a particular time or stage of construction, F
 e = eccentricity of resultant of all vertical forces, ℓ
 e_i = eccentricity of resultant of all vertical forces with respect to the x- and y-axes (e_x and e_y , respectively), ℓ
 E = vertical effects of earthquake simulating forces or related internal moment or force, F
 E_c = modulus of elasticity of concrete, F/ℓ^2
 E^s = modulus of elasticity of the materials used in the superstructure, F/ℓ^2
 E_s = soil modulus of elasticity, F/ℓ^2
 F_{vh} = vertical effects of lateral loads such as earth pressure, water pressure, fill pressure, surcharge pressure, or similar lateral loads, F
 G = shear modulus of concrete, F/ℓ^2
 h_w = height of any shearwalls in structure, ℓ
 H = settlement of foundation or point, ℓ
 H_{ci} = consolidation (or recompression) settlement of point i , ℓ
 AH = magnitude of computed foundation settlement, ℓ
 I = plan moment of inertia of footing (or mat) about any axis $x(I_x)$ or $y(I_y)$, ℓ^4
 I_B = moment of inertia of one unit width of the superstructure, ℓ^4
 I_F = moment of inertia per one unit width of the foundation, ℓ^4
 I_w = base shape factor depending on foundation shape and flexibility, ℓ^4
 i = vertical displacement of a node, ℓ
 J = torsion constant for finite grid elements, ℓ^4
 k_p = coefficient of subgrade reaction from a plate load test, F/ℓ^3
 k_{si} = coefficient of subgrade reaction contribution to node i , F/E'
 $k_{,si}$ = revised coefficient of subgrade reaction contribution to node i , F/ℓ^3 , see Section 6.8
 k_s = q/δ = coefficient (or modulus) of vertical subgrade reaction; generic term dependent on dimensions of loaded area, F/ℓ^3
 k_{vl} = basic value of coefficient of vertical subgrade reaction for a square area with width $B = 1$ ft, F/ℓ^3
 K = spring constant computed as contributory node area $\times k_s$, F/ℓ
 K_r = relative stiffness factor for foundation, Q
 L = live load or related internal moments and forces produced by the load, F
 L_s = sustained live loads used to estimate settlement, F . A typical value would be 50 percent of all live loads.
 L_{st} = stage service live load consisting of the sum of all unfactored live loads at a particular stage of construction, F
 M' = bending moment per unit length, $F\ell$
 M_E = overturning moment about base of foundation caused by an earthquake simulating force, $F\ell$

- M_F = overturning moment about base of foundation, caused by F_{vh} loads, $F\ell$
 M_w = overturning moment about base of foundation, caused by wind loads, blast, or similar lateral loads, $F\ell$
 M_o = largest overturning moment about the pressed edge or centroid of the base, $F\ell$
 M_R = resultant resisting moment, $F\ell$
 n = exponent used to relate plate k_p to mat k_s , Q
 P = any force acting perpendicular to base area, F
 q = soil contact pressure computed or actual, F/ℓ^2
 q_a = allowable soil contact pressure, F/ℓ^2
 q_u = unconfined (undrained) compression strength of a cohesive soil, F/ℓ^2
 q_{ult} = ultimate soil bearing capacity; a computed value to allow computation of ultimate strength design moments and shears for the foundation design, also used in overturning calculations, F/ℓ^2
 q_i = actual or computed soil contact pressure at a node point as furnished by the mat analysis. The contact pressures are evaluated by the geotechnical analysis for compatibility with q_a and foundation movement, F/ℓ^2
 A_q = average increase in soil pressure due to unit surface contact pressure, F/ℓ^2
 R_v = resultant of all given design loads acting perpendicular to base area, F
 $R_{v\ min}$ = least resultant of all forces acting perpendicular to base area under any condition of loading simultaneous with the overturning moment, F
 S = section modulus of mat plan area about a specified axis; S_x about x-axis; S_y about y-axis, ℓ^3
 SR = stability ratio (formerly safety factor), Q
 t_w = thickness of shearwalls, ℓ
 W = vertical effects of wind loads, blast, or similar lateral loads, F
 X_i = the maximum deflection of the spring at node i as a linear model, ℓ
 Z = foundation base length or length of beam column element, ℓ
 Z' = footing effective length measured from the pressed edge to the position at which the contact pressure is zero, ℓ
 δ = vertical soil displacement, ℓ
 α = torsion constant adjustment factor, Q
 λ = footing stiffness evaluation factor defined by Eq. (5-3), $1/\ell$
 μ = Poisson's ratio, Q
 v = distance from the pressed edge to $R_{v\ min}$ (see Fig. 4-1 and 4-2, ℓ
 Σ = summation symbol, Q
 γ = unit weight of soil, F/ℓ^3

1.2-Scope

This report addresses the design of shallow foundations carrying more than a single column or wall load. Although the report focuses on the structural aspects of the design, soil mechanics considerations are vital and the designer should include the soil-structure interaction phenomenon in connection with the design of combined footings and mats. The report excludes slabs-on-grade.

1.3-Definitions and loadings

Soil contact pressures acting on a combined footing or mat and the internal stresses produced by them should be determined from one of the load combinations given in Section 1.3.2, whichever produces the maximum value for the element under investigation. Critical maximum moment and shear may not necessarily occur with the largest simultaneously applied load at each column.

1.3.1 Definitions

Coefficient of vertical subgrade reaction k_s -Ratio between the vertical pressure against the footing or mat and the deflection at a point of the surface of contact

$$k_s = q/\delta$$

Combined footing-A structural unit or assembly of units supporting more than one column load.

Contact pressure q -Pressure acting at and perpendicular to the contact area between footing and soil, produced by the weight of the footing and all forces acting on it.

Continuous footing-A combined footing of prismatic or truncated shape, supporting two or more columns in a row.

Grid foundation-A combined footing, formed by intersecting continuous footings, loaded at the intersection points and covering much of the total area within the outer limits of assembly.

Mat foundation-A continuous footing supporting an array of columns in several rows in each direction, having a slablike shape with or without depressions or openings, covering an area of at least 75 percent of the total area within the outer limits of the assembly.

Mat area-Contact area between mat foundation and supporting soil.

Mat weight-Weight of mat foundation.

Modulus of subgrade reaction-See coefficient of vertical subgrade reaction.

Overburden-Weight of soil or backfill from base of foundation to ground surface. Overburden should be determined by the geotechnical engineer.

Overturning-The horizontal resultant of any combination of forces acting on the structure tending to rotate the structure as a whole about a horizontal axis.

Pressed edge-Edge of footing or mat along which the greatest soil pressure occurs under the condition of overturning.

Soil stress-strain modulus-Modulus of elasticity of soil and may be approximately related (Bowles 1982) to the coefficient of subgrade reaction by the equation

$$E_s = k_s B(1 - \mu^2) I_n$$

Soil pressure-See **contact pressure**.

Spring constant-Soil resistance in load per unit deflection obtained as the product of the contributory area and k_s . See coefficient of vertical subgrade reaction.

Stability ratio (SR)-Formally known as safety factor, it is the ratio of the resisting moment M_R to the overturning moment M_o .

Strip footing: See continuous footing definition.

Subgrade reaction: See contact pressure and **Chapter 3**.

Surcharge: Load applied to ground surface above the foundation.

1.3.2 Loadings-Loadings used for design should conform to the considerations and factors in Chapter 9 of ACI 318 unless more severe loading conditions are required by the governing code, agency, structure, or conditions.

1.3.2.1 Dead loads-Dead load D consisting of the sum of:

- a. Weight of superstructure.
- b. Weight of foundation.
- c. Weight of surcharge.
- d. Weight of fill occupying a known volume.

1.3.2.2 Live loads-Live load L consisting of the sum of:

- a. Stationary or moving loads, taking into account allowable reductions for multistory buildings or large floor areas, as stated by the applicable building code.
- b. Static equivalents of occasional impacts.

Repetitive impacts at regular intervals, such as those caused by drop hammers or similar machines, and vibratory excitations, are not covered by these design recommendations and require special treatment.

1.3.2.3 Effects of lateral loads-Vertical effects of lateral loads F_{vh} such as:

- a. Earth pressure.
- b. Water pressure.
- c. Fill pressure, surcharge pressure, or similar.
- d. Differential temperature, differential creep and shrinkage in concrete structures, and differential settlement.

Vertical effects of wind loads, -blast, or similar lateral loads W .

Vertical effects of earthquake simulating forces E .

Overturning moment about base of foundation, caused by earthquake simulating forces M_E .

Overturning moment about base of foundation, caused by F_{VH} loads M_F .

Overturning moment about foundation base, caused by wind loads, blast, or similar lateral loads M_w .

Dead load for overturning calculations D_o , consisting of the dead load of the structure and foundation but including any buoyancy effects caused by parts presently submerged or parts that may become submerged in the future. The influence of unsymmetrical fill loads on the overturning moments M_o , as well as the resultant of all vertical forces R_v , shall be investigated and used if found to have a reducing effect on the stability ratio SR .

Service live load L_s , consisting of the sum of all un-factored live loads, reasonably reduced and averaged over area and time to provide a useful magnitude for the evaluation of service settlements. Also called *sustained live load*.

Stage dead load D_{sr} , consisting of the un-factored Dead Load of the structure and foundation at a particular time or stage of construction.

Stage service live load L_{sr} , consisting of the sum of all un-factored Live Loads up to a particular time or stage of construction, reasonably reduced and averaged over area and time, to provide a useful magnitude for the evaluation of settlements at a certain stage.

1.4-Loading combinations

In the absence of conflicting code requirements, the following conditions should be analyzed in the design of combined footings and mats.

1.4.1 Evaluation of soil pressure-Select the combinations of unfactored (service) loads which will produce the greatest contact pressure on a base area of given shape and size. The allowable soil pressure should be determined by a geotechnical engineer based on a geotechnical investigation.

Loads should be of Types D , L , F_{vh} , W , and E as described in Section 1.3.2, and should include the vertical effects of moments caused by horizontal components of these forces and by eccentrically (eccentric with regard to the centroid of the area) applied vertical loads.

a. Consider buoyancy of submerged parts where this reduces the stability ratio or increases the contact pressures, as in flood conditions.

b. Obtain earthquake forces using the applicable building code, and rational analysis.

1.4.2 Foundation strength design-Although the allowable stress design according to the Alternate Design Method (ADM) is considered acceptable, it is best to design footings or mat foundations based on the Strength Design Method of ACI 318. Loading conditions applicable to the design of mat foundations are given in more detail in Chapter 6.

After the evaluation of soil pressures and settlement, apply the load factors in accordance with Section 9.2 of ACI 318.

1.4.3 Overturning-Select from the several applicable loading combinations the largest overturning moment M_o as the sum of all simultaneously applicable unfactored (service) load moments (M_F , M_w , and M_E) and the least unfactored resistance moment MR resulting from D_o and F_{vh} to determine the stability ratio SR against overturning in accordance with the provisions of Chapter 4.

1.4.4 Settlement-Select from the combinations of unfactored (service) loads, the combination which will produce the greatest settlement or deformation of the foundation, occurring either during and immediately after the load application or at a later date, depending on the type of subsoil. Loadings at various stages of construction such as D , D_{sp} , and L_{st} should be evaluated to determine the initial settlement, long-term settlement due to consolidation, and differential settlement of the foundation.

1.5-Allowable pressure

The maximum unfactored design contact pressures should not exceed the allowable soil pressure, q_a . q_a should be determined by a geotechnical engineer. Where wind or earthquake forces form a part of the load combination, the allowable soil pressure may be increased as allowed by the local code and in consultation with the geotechnical engineer.

1.6-Time-dependent considerations

Combined footings and mats are sensitive to time-dependent subsurface response. Time-dependent con-

siderations include (1) stage loading where the initial load consists principally of dead load; (2) foundation settlement with small time dependency such as mats on sand and soft carbonate rock; (3) foundation settlement which is time-dependent (usually termed consolidation settlements) where the foundation is sited over fine-grained soils of low permeability such as silt and clay or silt-clay mixtures; (4) variations in live loading; and (5) soil shear displacements. These five factors may produce time dependent changes in the shears and moments.

1.7-Design overview

Many structural engineers analyze and design mat foundations by computer using the finite element method. Soil response can be estimated by modeling with coupled or uncoupled "soil springs." The spring properties are usually calculated using a modulus of subgrade reaction, adjusted for footing size, tributary area to the node, effective depth, and change of modulus with depth. The use of uncoupled springs in the model is a simplified approximation. Section 6.7 considers a simple procedure to couple springs within the accuracy of the determination of subgrade response. The time-dependent characteristics of the soil response, consolidation settlement or partial-consolidation settlement, often can significantly influence the subgrade reaction values. Thus, the use of a single constant modulus of subgrade reaction can lead to misleading results.

Ball and Notch (1984), Focht et al. (1978) and Banavalkar and Ulrich (1984) address the design of mat foundations using the finite element method and time-dependent subgrade response. A simplified method, using tables and diagrams to calculate moments, shears, and deflections in a mat may be found in Bowles (1982), Hetenyi (1946), and Shukla (1984).

Caution should be exercised when using finite element analysis for soils. Without good empirical results, soil springs derived from values of subgrade reaction may only be a rough approximation of the actual response of soils. Some designers perform several finite element analyses with soil springs calculated from a range of subgrade moduli to obtain an adequate design.

CHAPTER 2-SOIL STRUCTURE INTERACTION

2.1-General

Foundations receive loads from the superstructure through columns, walls, or both and act to transmit these loads into the soil. The response of a footing is a complex interaction of the footing itself, the superstructure above, and the soil. That interaction may continue for a long time until final equilibrium is established between the superimposed loads and the supporting soil reactions. Moments, shears, and deflections can only be computed if these soil reactions can be determined.

2.2-Factors to be considered

No analytical method has been devised that can evaluate all of the various factors involved in the problem of soil-structure interaction and allow the accurate determination of the contact pressures and associated subgrade response. Simplifying assumptions must be made for the design of combined footings or mats. The validity of such simplifying assumptions and the accuracy of any resulting computations must be evaluated on the basis of the following variables.

2.2.1 Soil type below the footing-Any method of analyzing a combined footing should be based on a determination of the physical characteristics of the soil located below the footing. If such information is not available at the time the design is prepared, assumptions must be made and checked before construction to determine their validity. Consideration must be given to the increased unit pressures developed along the edges of rigid footings on nongranular soils and the opposite effect for footings on granular soils. The effect of embedment of the footing on pressure variation must also be considered.

2.2.2 Soil type at greater depths-Consideration of long-term consolidation of deep soil layers should be included in the analysis of combined footings and mats. Since soil consolidation may not be complete for a number of years, it is necessary to evaluate the behavior of the foundations immediately after the structure is built, and then calculate and superimpose stresses caused by consolidation.

2.2.3 Size of footing-The effect of the size of the footing on the magnitude and distribution of the contact pressure will vary with the type of soil. This factor is important where the ratio of perimeter to area of a footing affects the magnitude of contact pressures, such as in the case of the increased edge pressure, Section 2.2.1, and the long-term deformation under load, Section 2.2.2. The size of the footing must also be considered in the determination of the subgrade modulus. See Section 3.3.

2.2.4 Shape of footing-This factor also affects the perimeter-to-area ratio. Generally, simple geometric forms of squares and rectangles are used. Other shapes such as trapezoids, octagons, and circles are employed to respond to constraints dictated by the superstructure and property lines.

2.2.5 Eccentricity of loading-Analysis should include consideration of the variation of contact pressures from eccentric loading conditions.

2.2.6 Footing stiffness-The stiffness of the footing may influence the deformations that can occur at the contact surface and this will affect the variation of contact pressures (as will be seen in Fig. 3.1). If a flexible footing is founded on sand and the imposed load is uniformly distributed on top of the footing, then the soil pressure is also uniformly distributed. Since the resistance to pressure will be smallest at the edge of the footing, the settlement of the footing will be larger at the edges and smaller at the center. If, however, the footing stiffness is large enough that the footing can be

considered to act as a rigid body, a uniform settlement of the footing occurs and the pressure distribution must change to higher values at the center where the resistance to settlement is greater and lower values at the perimeter of the footing where the resistance to settlement is lower.

For nongranular soils, the stiffness of the footing will affect the problem in a different manner. The settlement of a relatively flexible footing supported on a clay soil will be greatest at the center of the footing although the contact soil pressure is uniform. This occurs because the distribution of soil pressure at greater depths has a higher intensity under the center of the footing. If the footing may be considered to act as a rigid body, the settlement must be uniform and the unit soil pressures are greater at the edge of the footing.

2.2.7 Superstructure stiffness-This factor tends to restrict the free response of the footing to the soil deformation. Redistribution of reactions occur within the superstructure frame as a result of its stiffness, which reduces the effects of differential settlements. This factor must be considered together with Section 2.2.6 to evaluate the validity of stresses computed on the basis of foundation modulus theories. Also, such redistribution may increase the stresses in elements of the superstructure.

2.2.8 Modulus of subgrade reaction-For small foundations [B less than 5 ft (1.5 m)], this soil property may be estimated on the basis of field experiments which yield load-deflection relationships, or on the basis of known soil characteristics. Soil behavior is generally more complicated than that which is assumed in the calculation of stresses by subgrade reaction theories. However, provided certain requirements and limitations are fulfilled, sufficiently accurate results can be obtained by the use of these theories. For mat foundations, this soil property cannot be reliably estimated on the basis of field plate load tests because the scale effects are too severe.

Sufficiently accurate results can be obtained using subgrade reaction theory, but modified to individually consider dead loading, live loading, size effects, and the associated subgrade response. Zones of different constant subgrade moduli can be considered to provide a more accurate estimate of the subgrade response as compared to that predicted by a single modulus of subgrade reaction. A method is described in Ball and Notch (1984) and Bowles (1982), and case histories are given in Banavalkar and Ulrich (1984) and Focht et al. (1978). Digital computers allow the designer to use mat models having discrete elements and soil behavior having variable moduli of subgrade reaction. The modulus of subgrade reaction is addressed in more detail in Section 3.3 and Chapter 6.

2.3-Investigation required to evaluate variable factors

Methods are available to estimate the influence of each of the soil structure interaction factors listed in Section 2.2. Desired properties of the structure and the

combined footing can be chosen by the design engineer. The designer, however, must usually accept the soil as it exists at the building site, and can only rely on careful subsurface exploration and testing, and geotechnical analyses to evaluate the soil properties affecting the design of combined footings and mats. In some instances it may be practical to improve soil properties. Some soil improvement methods include: dynamic consolidation, vibroflotation, vibroreplacement, surcharging, removal and replacement, and grouting.

CHAPTER 3-DISTRIBUTION OF SOIL REACTIONS

3.1- General

Except for unusual conditions, the contact pressures at the base of a combined footing may be assumed to follow either a distribution governed by elastic subgrade reaction or a straight-line distribution. At no place should the calculated contact pressure exceed the maximum allowable value, q_0 .

3.2-Straight-line distribution of soil pressure

A linear soil pressure distribution may be assumed for footings which can be considered to be a rigid body to the extent that only very small relative deformations result from the loading. This rigid body assumption may result from the spacing of the columns on the footing, from the stiffness of the footing itself, or the rigidity of the superstructure. Criteria that must be fulfilled to make this assumption valid are discussed in the sections following.

3.2.1 Contact pressure over total base area- If the resultant of all forces is such that all portions of the foundation contact area are in compression, the maximum and minimum soil pressure may then be calculated from the following formula, which applies only to rectangular base areas and only when e is located along one of the principal axes

$$q_{min}^{max} = \frac{\Sigma M'}{B \cdot Z} \pm \frac{6e}{Z} \quad (3-1)$$

3.2.2 Contact pressure over part of area- The soil pressure distribution should be assumed to be triangular. The resultant of this distribution has the same magnitude and colinear, but acts in the opposite direction of the resultant of the acting forces.

The maximum and minimum soil pressure under this condition can be calculated from the following expressions

At the footing edge

$$q_{ult} = \frac{2P}{3B} \left(\frac{Z}{2} - e \right) \quad (3-2)$$

At distance Z' from the pressed edge

$$q_{min} = 0 \quad (3-3)$$

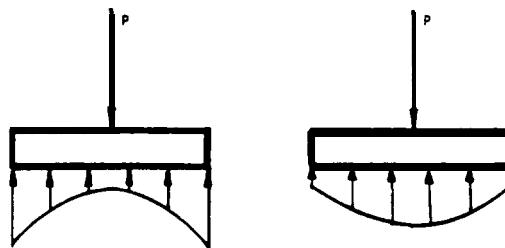

a. Foundation on saturated clay b. Foundation on cohesionless soil

Fig. 3.1-Contact pressure on bases of rigid foundations •

$$Z' = 3 \left(\frac{Z}{2} - e \right) \quad (3-4)$$

Eq. (3-1) to (3-4) are based on the assumption that no tensile (-) stresses exist between footing and soil. The equations may be applied with the details to be shown in the stability ratio calculation in Chapter 4, Fig. 4.2. Eq. (3-2) through (3-4) apply for cases where the resultant force falls out of the middle third of the base.

3.3-Distribution of soil pressure governed by the modulus of subgrade reaction

The assumption of a linear pressure distribution is commonly used and is satisfactory in most cases because of conservative load estimates and ample safety factors in materials and soil. The actual contact pressure distribution in cohesionless soils is concave; in cohesive soils, the pressure distribution is convex (Fig. 3.1). See Chapter 2 for more discussion of foundation stiff and pressure distributions.

The suggested initial design approach is to size the thickness for shear without using reinforcement. The flexural steel is then obtained by assuming a linear soil pressure distribution and using simplified procedures in which the foundation satisfies statics. The flexural steel may also be obtained by assuming that the foundation is an elastic member interacting with an elastic soil. Simplified methods are found in some textbooks and references: Bowles (1974, 1982); Hetenyi (1946); Kramrisch (1984); and Teng (1962).

3.3.1 Beams on elastic foundations - If a combined footing is assumed to be a flexible slab, it may be analyzed as a beam on elastic foundation using the methods found in Bowles (1974, 1982); Hetenyi (1946); Kramrisch and Rogers (1961); or Kramrisch (1984). The discrete element method has distinct advantages of allowing better modeling of boundary conditions of soil, load, and footing geometry than closed-form solutions of the Hetenyi type. The finite element method using beam elements is superior to other discrete element methods.

It is common in discrete element analyses of beams to use uncoupled springs. Special attention should be given to end springs because studies with large-scale models have shown that doubling the end springs was needed to give good agreement between the analysis

and performance (Bowles 1974). End-spring doubling for beams will give a minimal spring coupling effect.

3.3.2 Estimating the modulus of subgrade reaction - It is necessary to estimate a value for the modulus of subgrade reaction for use in elastic foundation analysis.

Several procedures are available for design:

a. Estimate a value from published sources (Bowles 1974, 1982, and 1984; Dept. of Navy 1982; Kramrisch 1984; Terzaghi 1955).

b. Estimate the value from a plate load test (Terzaghi 1955). Since plate load tests are of necessity on small plates, great care must be exercised to insure that results are properly extrapolated. The procedure (Sowers 1977) for converting the k_s of a plate k_p to that for the mat k_s may be as in the following

$$K_s = K_p \left(\frac{B_p}{B_m} \right)^n \quad (3-8)$$

where n ranges from 0.5 to 0.7 commonly. One must allow for the depth of compressible strata beneath the mat and if it is less than about $4B$ the designer should use lower values of n .

c. Estimate the value based on laboratory or in situ tests to determine the elastic parameters of the foundation material (Bowles 1982). This may be done by numerically integrating the strain over the depth of influence to obtain a settlement ΔH and back computing k_s as

$$K_s = q / \Delta H$$

Several values of strain should be used in the influence depth of approximately $4B$ where B is the largest dimension of the base. Values of elastic parameters determined in the laboratory are heavily dependent on sample disturbance and the quality and type of triaxial test results.

d. Use one of the preceding methods for estimating the modulus of subgrade reaction, but, in addition, consider the time-dependent subgrade response to the loading conditions. This time-dependent soil response may be consolidation settlement or partial-elastic movement. An iterative procedure outlined in Section 6.8, and described by Ulrich (1988), Banavalkar and Ulrich (1984), and Focht et al. (1978), may be necessary to compare the mat deflections with computed soil response. The computed soil responses are used in a manner similar to producing the coupling factor to back compute springs at appropriate nodes. Since the soil response profile is based on contact stresses which are in turn based on mat loads, flexibility, and modulus of subgrade reaction, iterations are necessary until the computed mat deflection and soil response converge within user-acceptable tolerance.

CHAPTER 4-COMBINED FOOTINGS

4.1-Rectangular-shaped footings

The length and width of rectangular-shaped footings should be established such that the maximum contact

pressure at no place exceeds the allowable soil pressure. All moments should be calculated about the centroid of the footing area and the bottom of the footing. All footing dimensions should be computed on the assumption that the footing acts as a rigid body. When the resultant of the column loads, including consideration of the moments from lateral forces, coincides with the centroid of the footing area, the contact pressure may be assumed to be uniform over the entire area of the footing.

When the resultant is eccentric with respect to the center of the footing area, the contact pressure may be assumed to follow a linear distribution based on the assumption that the footing acts as a rigid body (see Section 3.2). The contact pressure varies from a maximum at the pressed edge to a minimum either beneath the footing or at the opposite edge.

Although the effect of horizontal forces are beyond the scope of this analysis and design procedure, horizontal forces can provide a major component to the vertical resultant. Horizontal forces that can generate vertical components to the foundation may originate from (but are not limited to) wind, earth pressure, and unbalanced hydrostatic pressure. A careful examination of the free body must be made with the geotechnical engineer to fully define the force systems acting on the foundation before the structural analyses are attempted.

4.2-Trapezoidal or irregularly shaped footings

To reduce eccentric loading conditions, a trapezoidal or irregularly shaped footing may be designed. In this case the footing can be considered to act as a rigid body and the soil pressure determined in a manner similar to that for a rectangular footing.

4.3-Overturning calculations

For calculations that involve overturning, use the combination of loading that produces the greatest ratio of overturning moment to the corresponding vertical load.

For footings resting on rock or very hard soil, overturning will occur when the eccentricity e of the loads P falls outside the footing edge. Where the eccentricity is inside the footing edge, the stability ratio SR against overturning can be evaluated from

$$SR = M_R / M_o \quad (4-1)$$

In Eq. (4-1), M_o is the maximum overturning moment and M_R is the resisting moment caused by the minimum dead weight of the structure; both are calculated about the pressed edge of the footing. The stability ratio should generally not be less than 1.5.

Overturning may occur by yielding of the subsoil inside and along the pressed edge of the footing. In this case, rectangular or triangular distributions of the soil pressure along the pressed edge of the footing as shown in Fig. 4.1 and 4.2, respectively, are indicated. In this case the stability ratio SR against overturning is calcu-

lated from Eq. (4-1), with

$$M_R = R_v \min (c - v) \quad (4-2)$$

The calculation of the stability ratio is illustrated in Fig. 4.1 and 4.2. Since the actual pressure distribution may fall between triangular and rectangular, the true stability ratio may be less than that indicated by rectangular distribution. A stability ratio of at least 1.5 is recommended for overturning.

CHAPTER 5-GRID FOUNDATIONS AND STRIP FOOTINGS

SUPPORTING MORE THAN TWO COLUMNS

5.1 -General

Strip footings are used to support two or more columns and other loadings in a line. They are commonly used where it is desirable to assume a constant soil pressure beneath the foundation; where site and building geometries require a lateral load transfer to exterior columns; or where columns in a line are too close to be supported by individual foundations. Grid foundations should be analyzed as independent continuous strips using column loads proportioned in direct ratio to the stiffness of the strips acting in each direction. The following design principles defined for continuous strip footings will also apply with modifications for grid foundations.

5.2-Footings supporting rigid structures

Continuous strip footings supporting structures which, because of their stiffness, will not allow the individual columns to settle differentially, may be designed using the rigid body assumption with a linear distribution of soil pressure. This distribution can be determined based on statics.

To determine the approximate stiffness of the structure, an analysis must be made comparing the combined stiffness of the footing, superstructure framing members, and shearwalls with the stiffness of the soil. This relative stiffness K_r will determine whether the footing should be considered as flexible or to act as a rigid body. The following formulas (Meyerhof 1953) may be used in this analysis

$$K_r = \frac{E' I_B}{E_s B^3} \quad (5-1)$$

An approximate value of $E' I_B$ per unit width of building can be determined by summing the flexural stiffness of the footing $E' I_F$, the flexural stiffness of each framed member $E' I_b'$ and the flexural stiffness of any shearwalls $E' t_w h_w^3 / 12$ where t_w and h_w are the thickness and height of the walls, respectively

$$E' I_B = E' I_F + \Sigma E' I_b' + E' \frac{t_w h_w^3}{12} \quad (5-2)$$

Computations indicate that as the relative stiffness K_r increases, the differential settlement decreases rapidly.

For $K_r = 0$, the ratio of differential to total settlement is 0.5 for a long footing and 0.35 for a square one. For $K_r = 0.5$, the ratio of differential to total settlement is about 0.1.

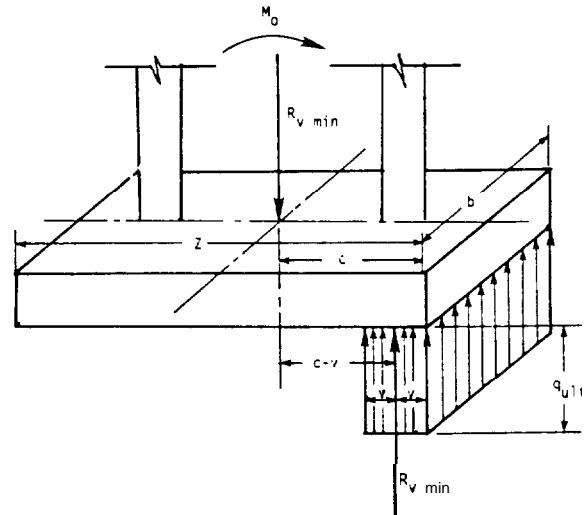

STABILITY RATIO: $S.R. = \frac{M_o}{M} \geq 1.5$

WHERE $M_R = R_v \min (c - v)$

$v = \frac{R_v \min}{2b q_{ult}}$

Fig. 4.1-Stability ratio calculation (rectangular distributions of soil pressure along pressed edge of footing)

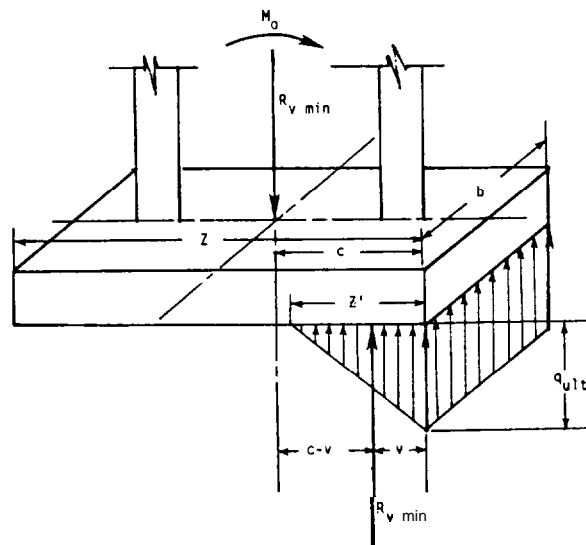

STABILITY RATIO: $S.R. = \frac{M_o}{M} \geq 1.5$

WHERE $M_R = R_v \min (c - v)$

$v = \frac{2R_v \min}{3b q_{ult}}$

Fig. 4.2-Stability ratio calculation (triangular distributions of soil pressure along pressed edge of footing)

If the analysis of the relative stiffness of the footing yields a value of 0.5, the footing can be considered rigid and the variation of soil pressure determined on the basis of simple statics. If the relative stiffness factor is found to be less than 0.5, the footing should be designed as a flexible member using the foundation modulus approach as described under Section 5.4.

5.3-Column spacing

The column spacing on continuous footings is important in determining the variation in soil pressure distribution. If the average of two adjacent spans in a continuous strip having adjacent loads and column spacings that vary by not more than 20 percent of the greater value, and is less than $1.75/\lambda$, the footing can be considered rigid and the variation of soil pressure determined on the basis of simple statics.

The beam-on-elastic foundation method (see Section 2.2.8) should be used if the average of two adjacent spans as limited above is greater than $1.75/\lambda$.

For general cases falling outside the limitations given above, the critical spacing at which the subgrade modulus theory becomes effective should be determined individually.

The factor λ is

$$\lambda = \sqrt[4]{\frac{K_s}{4E_c I}} \quad (5-3)$$

5.4-Design procedure for flexible footings

A flexible strip footing (either isolated or taken from a mat) should be analyzed as a beam-on-elastic foundation. Thickness is normally established on the basis of allowable wide beam or punching shear without use of shear reinforcement; however, this does not prohibit the designer's use of shear reinforcement in specific situations.

Either closed-form solutions (Hetenyi 1946) or computer methods can be used in the analysis.

5.5-Simplified procedure for flexible footings

The evaluation of moments and shears can be simplified from the procedure involved in the classical theory of a beam supported by subgrade reactions, if the footing meets the following basic requirements (Kramrisch and Rogers 1961 and Kramrisch 1984):

- The minimum number of bays is three.
- The variation in adjacent column loads is not greater than 20 percent.
- The variation in adjacent spans is not greater than 20 percent.
- The average of adjacent spans is between the limits $1.75/\lambda$ and $3.50/\lambda$.

If these limitations are met, the contact pressures can be assumed to vary linearly, with the maximum value under the columns and a minimum value at the center of each bay. This simplified procedure is described in some detail by Kramrisch and Rogers (1961) and Kramrisch (1984).

CHAPTER 6-MAT FOUNDATIONS

6.1-General

Mat foundations are commonly used on erratic or relatively weak subsurfaces where a large number of spread footings would be required and a well defined bearing stratum for deep foundations is not near the foundation base. Often, a mat foundation is used when spread footings cover more than one-half the foundation area. A common mat foundation configuration is shown in Fig. 6.1(a).

The flexural stiffness EI of the mat may be of considerable aid in the horizontal transfer of column loads to the soil (similar to a spread footing) and may aid in limiting differential settlements between adjacent columns. Structure tilt may be more pronounced if the mat is very rigid. Load concentrations and weak subsurface conditions can offset the benefits of mat flexural stiffness.

Mats are often placed so that the thickness of the mat is fully embedded in the surrounding soil. Mats for buildings are usually beneath a basement that extends at least one-half story below the surrounding grade. Additionally, the top mat surface may function as a basement floor. However, experience has shown that utilities and piping are more easily installed and maintained if they are placed above the mat concrete. Depending on the structure geometry and weight, a mat foundation may "float" the structure in the soil so that settlement is controlled. In general, the pressure causing settlement in a mat analysis may be computed as

$$\text{Net pressure} = \frac{\{[\text{Total (including mat) structure weight}] - \text{Weight of excavated soil}\}}{\text{Mat area}} \quad (6-1)$$

Part of the total structure weight may be controlled by using cellular mat construction, as illustrated in Fig. 6.1(b). Another means of increasing mat stiffness while limiting mat weight is to use inverted ribs between columns in the basement area as in Fig. 6.1(c). The cells in a cellular mat may be used for liquid storage or to alter the weight by filling or pumping with water. This may be of some use in controlling differential settlement or tilt.

Mats may be designed and analyzed as either rigid bodies or as flexible plates supported by an elastic foundation (the soil). A combination analysis is common in current practice. An exact theoretical design of a mat as a plate on an elastic foundation can be made; however, a number of factors rapidly reduce the exactness to a combination of approximations. These include:

1. Great difficulty in predicting subgrade responses and assigning even approximate elastic parameters to the soil.
2. Finite soil-strata thickness and variations in soil properties both horizontally and vertically.
3. Mat shape.
4. Variety of superstructure loads and assumptions in their development.

5. Effect of superstructure stiffness on mat (and vice versa).

With these factors in mind, it is necessary to design conservatively to maintain an adequate factor of safety. The designer should work closely with the geotechnical engineer to form realistic subgrade response predictions, and not rely on values from textbooks.

There are a large number of commercially available computer programs that can be used for a mat analysis. ACI Committee 336 makes no individual program recommendation since the program user is responsible for the design. A program should be used that the designer is most familiar with or has investigated sufficiently to be certain that the analyses and output are correct.

6.1.1 Excavation heave-Heave or expansion of the base soil into the excavation often occurs when excavating for a mat foundation. The amount depends on several factors:

- Depth of excavation (amount of lost overburden pressure).
- Type of soil (sand or clay)-soil heave is less for sand than clay. The principal heave in sand overlying clay is usually developed in the clay.
- Previous stress history of the soil.
- Pore pressures developed in the soil during excavation from construction operations.

The amount of heave can range from very little-1/2 to 2 in. (12 to 50 mm)-to much larger values. Ulrich and Focht (1982) report values in the Houston, Tex., area of as much as 4 in. (102 mm). Some heave is al-

most immediately recovered when the mat concrete is placed, since concrete density is from 1.5 to 2.5 times that of soil.

The influence of heave on subgrade response should be determined by the geotechnical engineer working closely with the structural designer. Recovery of the heave remaining after placing the mat must be treated as either a recompression or as an elastic problem. If the problem is analyzed as a recompression problem, the subsurface response related to recompression should be obtained from the geotechnical engineer. The subsurface response may be in the form of a recompression index or deflections computed by the geotechnical engineer based on elastic and consolidation subsurface behavior. If the recovery is treated as an elastic problem, the modulus of subgrade reaction should be reduced as outlined in Section 6.8, where the consolidation settlement used in Eq. (6.8) includes the amount of recompression.

6.1.2 Design procedure-A mat may be designed using either the Strength Design Method (SDM) or working stress design according to the Alternate Design Method (ADM) of ACI 318-83, Appendix B. The ADM is an earlier method, and most designers prefer to use the SDM.

The suggested design procedure is to:

- Proportion the mat plan using unfactored loads and any overturning moments as

$$q = \frac{\Sigma P}{BZ} \left(1 \pm \frac{6e_x}{B} \pm \frac{6e_y}{Z} \right) \quad (6-2)$$

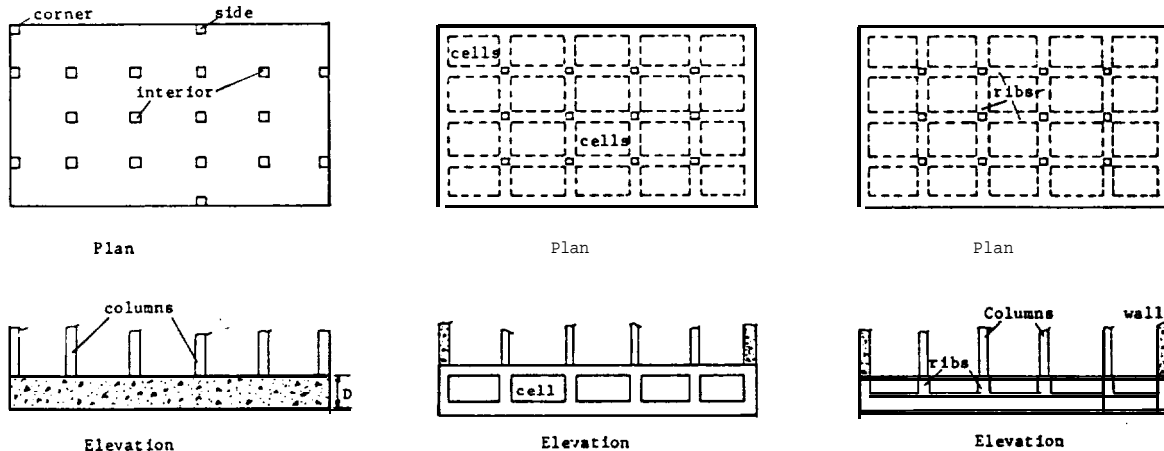

- Solid mat of reinforced concrete; most common configuration. D = depth for shear, moment or stability and ranges from about 1.5 to 6+ ft (0.5 to 2+ m).
- Mat using cell construction. Cells may be filled with water or sand to control settlements or for stability.
- Ribbed mat used to control bending with minimum concrete. Ribs may be either one or two-way.

Fig. 6.1--Mat configurations for various applications: (a) mat ideally suited for finite element or finite grid method; (b) mat that can be modeled either as two parallel plates with the upper plate supported by cell walls modeled as springs, or as a series of plates supported on all edges; and (c) mat ideally suited for analysis using finite grid method, since ribs make direct formulation of element properties difficult

The eccentricity e_x, e_y of the resultant of column loads ΣP includes the effect of any column moments and any overturning moment due to wind or other effects. The eccentricities e_x, e_y are computed using statics, summing moments about two of the adjacent mat edges [say, Lines O-X, O-Y of Fig. 6.1(a)]. The values of design e_x, e_y will be slightly different if computed using unfactored or factored design loads.

The actual unfactored loads are used here as the comparison to the soil pressure furnished by the geotechnical engineer is

$$q \leq q_u$$

The allowable soil pressure may be furnished as one or more values depending on long-term loading or including transient loads such as wind and snow. The soil pressure furnished by the geotechnical engineer is used directly in the ADM procedure. For strength design it is necessary to factor this furnished allowable soil pressure to a pseudo "ultimate" value, which may be done as follows

$$q_{ult} = q_u \left(\frac{\text{sum of factored design loads}}{\text{sum of unfactored design loads}} \right) \quad (6-3)$$

2. Compute the minimum mat thickness based on punching shear at critical columns (corners, sides, interior, etc.), refer to Fig. 6.1(a), based on column load and shear perimeter. It is common practice not to use shear reinforcement so that the mat depth is a maximum. This increases the flexural stiffness and increases the reliability of using Eq. (6-2).

3. Design the reinforcing steel for bending by treating the mat as a rigid body and considering strips both ways, if the following criteria are met:

- a. Column spacing is $< 1.75/\lambda$, or the mat is very thick.
- b. Variation in column loads and spacing is not over 20 percent. For mats not meeting this criteria, go immediately to Step 4.

These strips are analyzed as combined footings with multiple columns loaded with the soil pressure on the strip, and column reactions equal to the factored (or unfactored) loads obtained from the superstructure analysis. Since a mat transfers load horizontally, any given strip may not satisfy a vertical load summation unless consideration is given to the shear transfer between strips. Bowles (1982) illustrates this problem and a method of analysis so the strips satisfy statics.

4. Perform an approximate analysis (Shukla 1984) or a computer analysis of the mat and revise the rigid body design as necessary. An approximate analysis can be made using the method suggested by ACI 336.2R-66 to calculate moments, shears, and deflections in a mat with the help of charts. Charts for this procedure are given in Shukla (1984) and Hetenyi (1946). A completed example problem is given in the paper to assist the designer. The geotechnical engineer should furnish the designer subgrade response values even when a simplified design method is used.

Computer analysis for mat foundations is usually based on an approximation where the mat is divided into a number of discrete (finite) elements using grid lines. There are three general discrete element formulations which may be used:

- a. Finite difference (FD).
- b. Finite grid method (FGM).
- c. Finite element method (FEM).

These latter two methods can be used for mats with curved boundaries or notches with re-entrant corners as in Fig. 6.2. All three of these methods use the modulus of subgrade reaction k , as the soil contribution to the structural model. This has been considered in Sections 2.3, 3.3, and 5.4, and will be considered in Sections 6.7 and 6.8. Computers (micro to mainframe) and available software make the use of any of the discrete element methods economical and rapid. The finite element model shown in Fig. 6.2(b) indicates a simple gridding that produces 70 elements, 82 nodes, and 246 equations with a band width computed as shown.

6.2-Finite difference method

The finite difference method is a procedure which provides quite good results for the approximations used. This procedure was used extensively in the past, but is sometimes used to verify finite element methods. It is particularly appealing since it does not require massive computer resources. Fig. 6.3 shows the finite difference method with node equation for interior node given.

6.3-Finite grid method

This method discretizes the mat into a number of beam-column elements with bending and torsional resistance (Fig. 6.4). The torsional resistance is used to incorporate the plate twist using the shear modulus G . In finite element terminology, the FGM produces non-conforming elements, i.e., interelement compatibility is insured only at the nodes. A theoretical development of this method specifically for mats is found in Bowles (1974, 1976, and 1982).

6.4-Finite element method

This method discretizes the mat into a number of rectangular and/or triangular elements (Fig. 6.5). Earlier programs used displacement functions which purported to produce conforming interelement compatibility (i.e., compatibility both at nodes and along element boundaries between adjacent elements).

For bending, the nodal displacement and slopes in the X- and Y-direction are required. This results in taking partial derivatives of the displacement function. First, however, one must delete one term for the triangle or add two nodes and use the fifteen-term displacement function. Similarly, for the rectangle one must drop three terms or add a node. There are computer programs which drop terms, combine terms, and add nodes. Any of the programs will give about the same computed output so the preferred program is that one most familiar to the user.

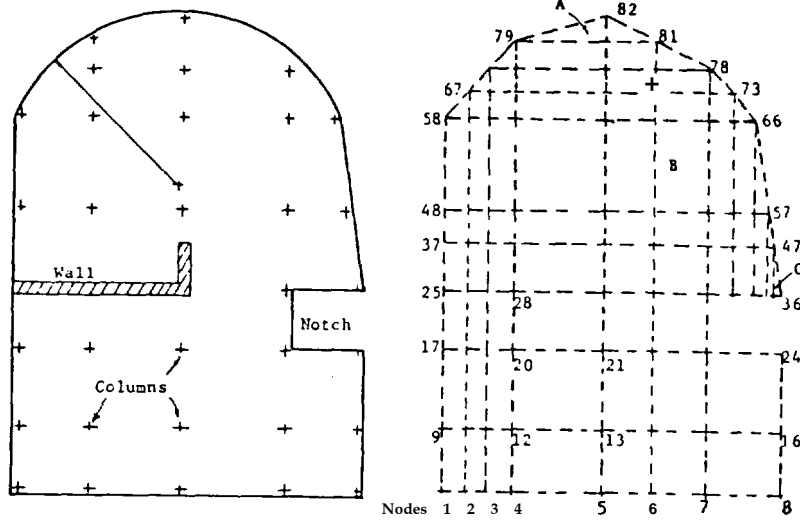

This grid produces 70 elements, 82 nodes, 246 equations
 Bandwidth depends on node numbering scheme = 3 (largest element node difference + 1)
 Here, bandwidth = 3(37 + 25 + 1) = 39

a. Mat with wall, notch, and irregular shape including a curved area.

b. Finite element model for mat "a." Curved area has been replaced with a series of straight segments, and triangles are utilized. Gridding shown here is to illustrate method of modeling and may require refinement in some cases.

Fig. 6.2-Mat gridding for either finite grid or finite element method

6.4.1 Iso-parametric elements-An element is of the iso-parametric type if the same function can be used to describe both shape and displacement. Some computer programs suitable for mat (or plate) analysis use this methodology. The method is heavily computation-intensive but has a particular advantage over displacement functions in that any given element may contain a different number of nodes than others as illustrated in Fig. 6.5.

Interpolation functions are used together with an approximation for area integration. Good results are claimed with care in using enough interpolation points.

Some programs using the iso-parametric formulation may not have the necessary routines to include extra nodes on select elements and in these cases there is usually no advantage of the iso-parametric element over the displacement function approach. Neither of these approaches is exact, unless substantial effort is expended.

Cook (1974), Ghali and Neville (1972), and Zienkiewicz (1977) describe formulation of the finite element stiffness matrix.

Advantages of the FEM include:

- a. The solution is particularly mathematically efficient.
- b. Boundary condition displacements can be modeled.
- c. The iso-parametric approach can allow use of mid-side nodes, which produces some mesh refinement without the large increase in grid lines of the other methods.

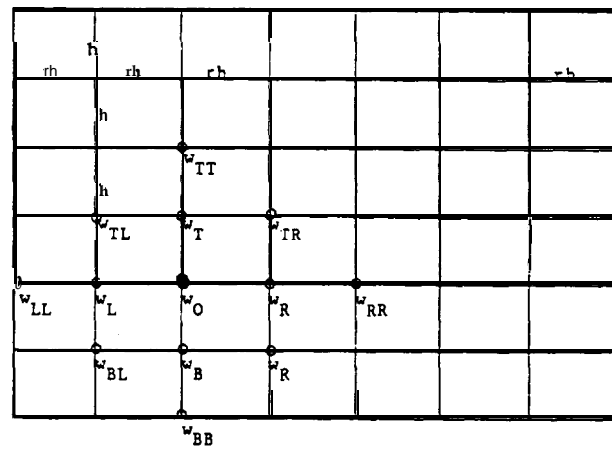

$$\text{For } r = 1: 20(w_O + k_s h^4/D) - 8(w_T + w_B + w_R + w_L) + 2(w_{TL} + w_{TR} + w_{BL} + w_{BR}) + (w_{TT} + w_{BB} + w_{LL} + w_{RR}) = Ph^2/D$$

Fig. 6.3-Finite difference method with node equation for interior node given. Separate equations are required for corners, sides, and first nodes in from sides

Disadvantages of the FEM include:

- a. The formulation of the stiffness matrix is computationally intensive.
- b. It is very difficult to include a concentrated moment at the nodes as the methodology uses moment per unit of width.

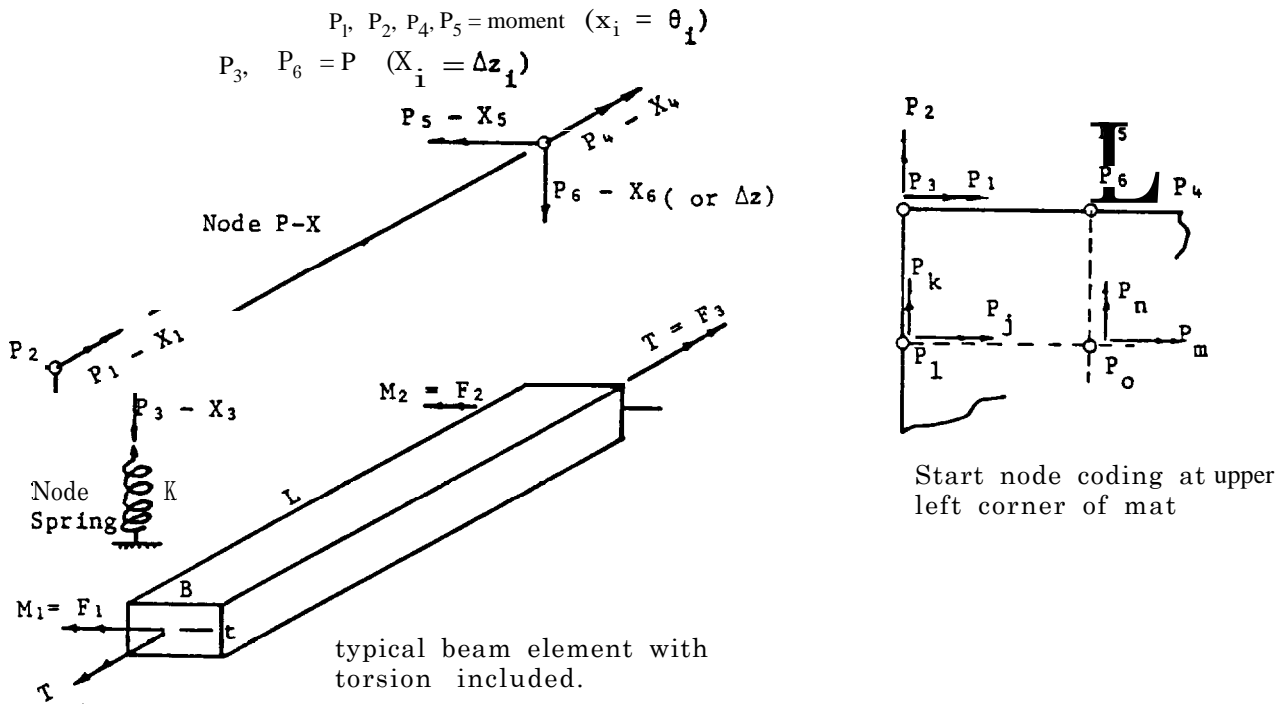
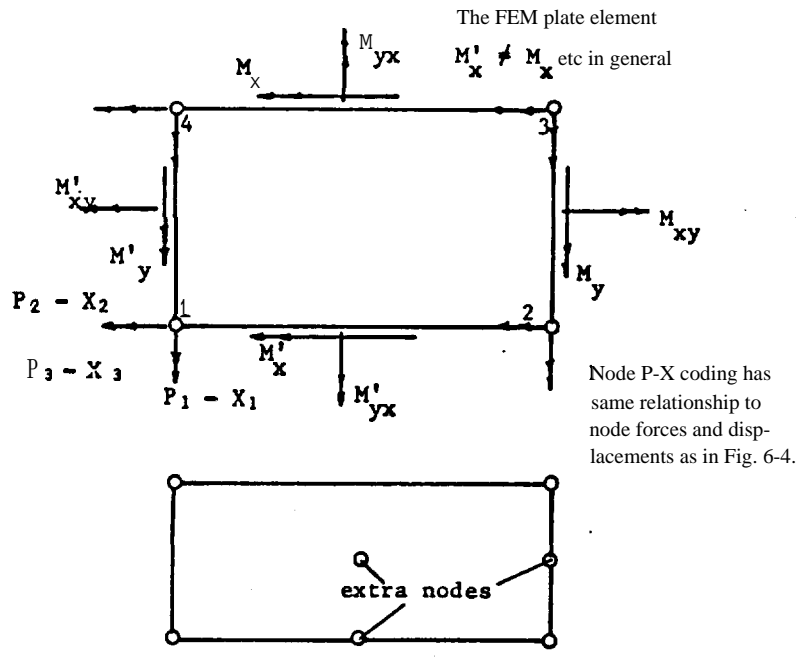

Fig. 6.4-Element coding for nodes and element forces for the finite grid method. Dimension: B and t used both for element moment of inertia i and torsion inertia J



Additional nodes are allowed with some programs where isoparametric elements using shape functions are programmed.

Fig. 6.5-Typical rectangular finite element using the FEM plate formulation. Continuing P-Xi coding counterclockwise around the four-node element gives twelve element displacements: four translations and eight rotations

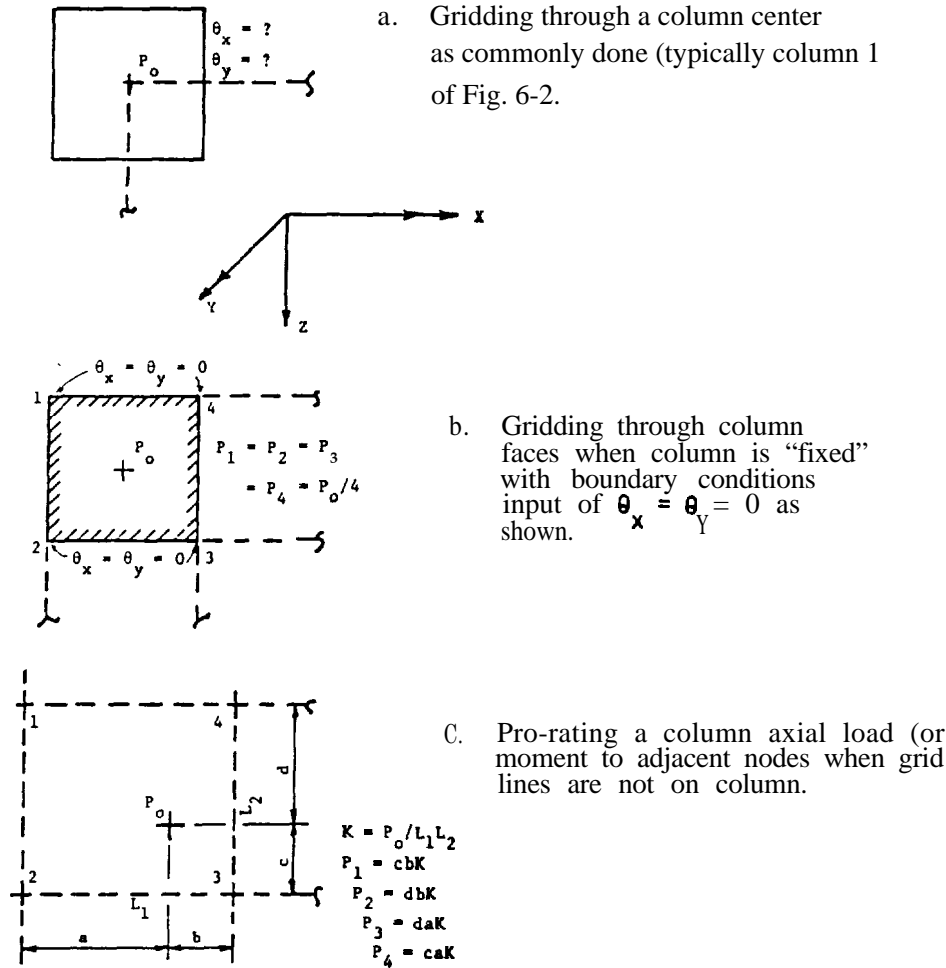

Fig. 6.6--Procedures for modeling columns and column loads into one of the discrete (finite) element procedures

c. Often a statics summation of nodal moments is only approximated. This is often the case where the common elements include triangles or a mix of triangles and rectangles.

d. It requires interpretation of the plate twist moment M_{xy} that is output.

e. It is not directly amenable to increasing the nodal degree-of-freedom from three to six for pile caps as is the finite grid method (FGM).

f. The stiffness matrix is the same size as the FGM but three times the size of the FD method.

The FEM is particularly sensitive to aspect ratios of rectangular elements and intersection angles of triangles. In practical problems, the designer has little control over these factors other than increasing the grid lines (and number of nodes). For example, Elements A, B, and C of Fig. 6.2 may not give reliable computed results. This deficiency may be overcome for that example by adding grid lines, but this is at the expense of increasing user input and a rapid increase in the size of the stiffness matrix since it increases at three times the number of nodes.

6.5-Column loads

Columns apply axial loads, shears, and moments to a mat. Generally the shear is neglected since its effect

would be to slide the foundation laterally. There could also be a tendency to compress the mat between two columns; however, the AE_c/Z term is so large that this movement is negligible and can be ignored.

There is no practical way to incorporate horizontal loads into the mat, except at the expense of additional computations. For example, the FGM would require six degree-of-freedom nodes to allow this. This represents prohibitive effort for the results-except for pile caps, where some (or all) of the horizontal shear force may be assumed to be carried by the piles.

The mat may be gridded through the column centers (Fig. 6.6) with any of the methods. If column fixity, zero rotation, at the four column nodes of Fig. 6-6(b) is modeled, the grid lines must be taken through the column faces for the FGM or FEM.

If the column lies within the grid spacing, the adjacent nodes are loaded with a portion of the load. The simple beam analogy shown in Fig. 6.6(c) is sufficiently accurate and may be used for both axial load and column moments.

6.6-Symmetry

Consideration should be given to any mat symmetry to reduce the total number of nodes to be analyzed. This is critical in the FGM and FEM in particular since I

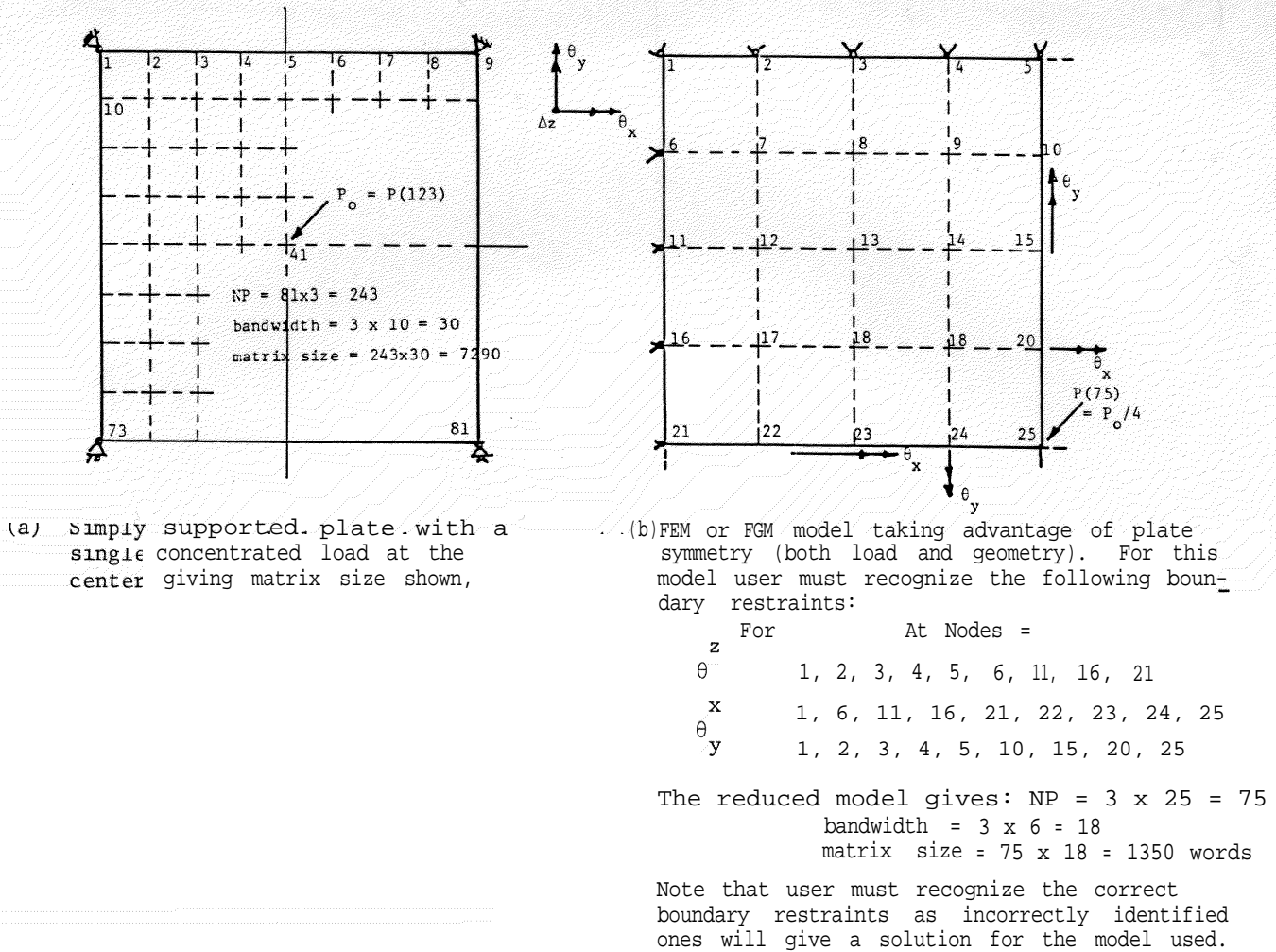

Fig. 6.7—Using symmetry to reduce the size of matrix from 7290 to 1350 words substantially reduces computation time

there are three equations per node so that a mat with 400 or more nodes will require substantial memory and may require special matrix reduction routines which block the stiffness matrix to and from a disk file.

With symmetry, perhaps only one-quarter or one-half of the mat will require modeling. If there is symmetry only for selected load cases and not for others, nothing is gained by attempting to analyze some load cases with a reduced mat plan. Fig. 6.7 illustrates the use of symmetry to reduce a simple plate problem by approximately one-quarter. Success in using symmetry to reduce the problem size depends very heavily on being able to recognize and input the correct nodal boundary conditions along the axes of symmetry.

A careful study of whether symmetry applies should be made prior to any modeling, since a substantial amount of engineering and programming effort is often required in developing the element data.

A major factor where computer memory is adequate is whether there is sufficient advantage in utilization of any symmetry to reduce the problem size. Some savings of computer resources are offset with engineering time of identification and input of the extra boundary

conditions. It is very easy to make an error, and careful inspection of the output displacement matrix is necessary.

6.7-Node coupling of soil effects

When the mat is interfaced with the ground, the soil effect is concentrated at the grid node for computer analysis. The most common soil-to-node concentration effect produces the so-called Winkler foundation. That is, the modulus of subgrade reaction is used and the concentration is simply

$$K = \text{Contributory area} \times k_s \quad (6-7)$$

This is shown for several element shapes in Fig. 6.8. Since the concentration is a product of area and k_s , the result has the units of a spring and is commonly called a soil spring.

Strictly, nodes might be coupled [Fig. 6.9(b)], but this is seldom done. If a Winkler foundation is used, the soil spring K directly adds (superposition) to every third diagonal term of the stiffness matrix, making it very easy to model excessive displacements into the soil

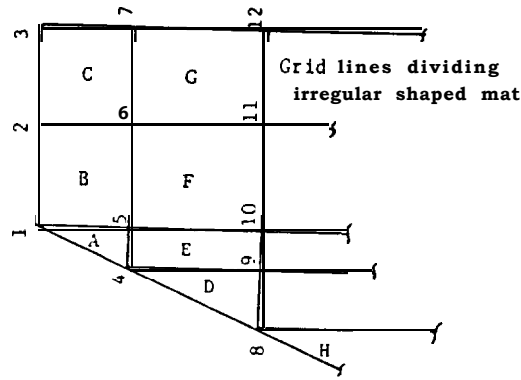

Compute spring constants K_i as follows:

Let the area of any element such as A, B, C, . . . = A, B, C, . . .

Let the modulus of subgrade reaction within any element be k_A, k_B , etc.

Then: $K_1 = Ak_A/3 + Bk_B/4$

$K_2 = Bk_B/4 + Ck_C/4$ (typical side spring)

$K_3 = Ck_C/4$ (typical corner spring)

$K_4 = Ak_A/3 + Ek_E/4 + Dk_D/3$

$K_5 = Ak_A/3 + (Bk_B + Ek_E + Fk_F)/4$

$K_6 = (Bk_B + Ck_C + Fk_F + Gk_G)/4$ (typical interior spring)

A computer routine can develop corner, side and interior springs easily but is substantially more difficult for springs with contributions from triangle elements.

A good computer program should be able to compute the typical corner, side and interior springs and allow the user to input by hand springs such as for nodes 1, 4, and 8 above.

Fig. 6.8-Computation of uncoupled Winkler-type soil node springs

or mat-soil separation at nodes. This allows reuse of the stiffness matrix by removing the spring as necessary on subsequent cycles. Since the elastic parameters E_s and k_s usually increase with depth from overburden and pre-consolidation it appears this may lessen the effect of ignoring coupling (Christian 1976).

If coupling were undertaken, the equations to be programmed become much more complicated and, additionally, fractions of the soil concentration appear in off-diagonal terms of the stiffness matrix. If nonlinearity is allowed (soil separation or excessive deformation) the stiffness matrix requires substantial modifications and it becomes about as easy to completely rebuild it on subsequent cycles.

The most direct and obvious effect of coupling versus noncoupling is that this analysis of a uniformly loaded mat (an oil tank base) will produce a dishing profile across the slab with coupling and a constant settlement profile without coupling. Boussinesq theory indicates a dishing profile is correct.

It is possible to indirectly allow for coupling as follows (Bowles 1984 and Fig. 6.10):

1. Obtain a vertical pressure profile for the mat using any accepted procedure. The Newmark (1935) method in Bowles (1984) might be programmed or the

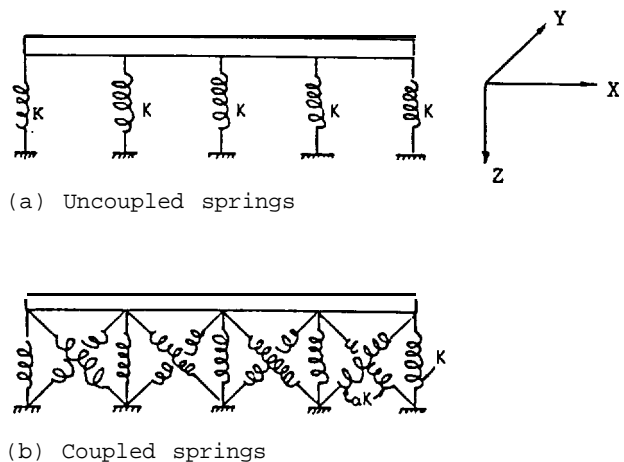
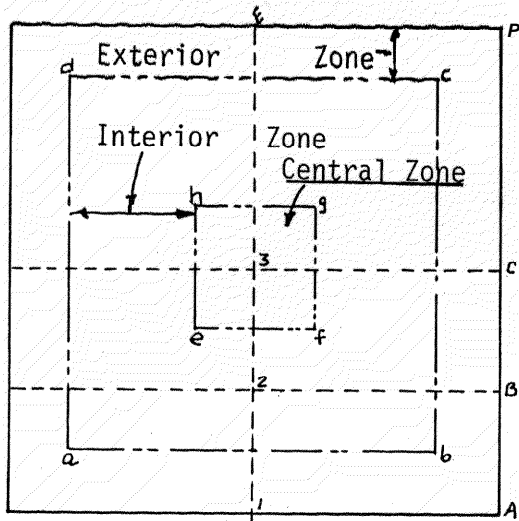

Fig. 6.9-Soil springs in X-Z plane

pressure bulbs in Bowles (1982) might be used. This is done at sufficient points so that the mat plan can be subsequently zoned with different values of k_s . Use a convenient influence depth of $3B$ to $5B$, subject to the approval of the geotechnical engineer. Only slightly



Point 1 has 2 contributing areas of size 1-A-D-E-1

Point 2 has 4 areas with 2 contributions from 2-B-A-1-2 and 2-B-D-E-2

Point 3 has 4 contributing areas from 3-C-D-E-3

Possible zones are as shown with outer zone using k_s furnished. Other zones are bounded by a-b-c-d and e-f-g-h; inner zone is e-f-g-h.

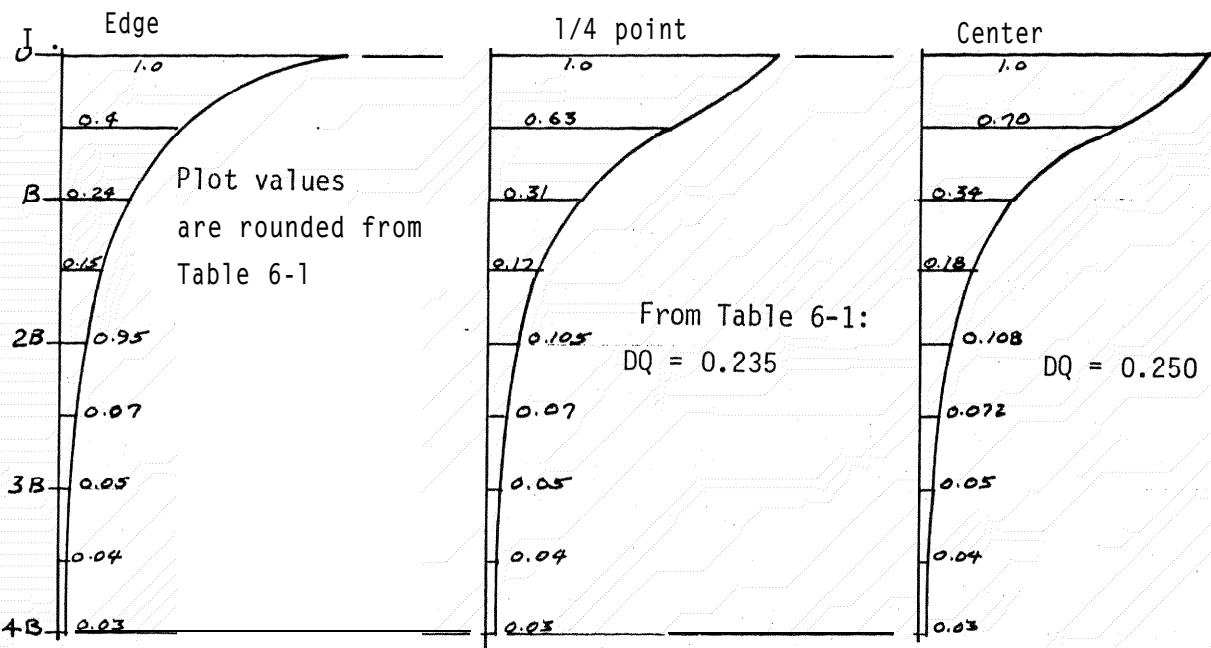

Compute average DQ as:

$$DQ = \frac{0.5B}{4B} (1.0 + \frac{0.028}{2} + 0.40 + 0.24 + 0.146 + 0.095 + 0.066 + 0.048 + 0.036) = 0.193(q_0) \text{ Using values directly from Table 6-1}$$

For $k_s = 500$: Obtain edge $k = 500$; zone 1 = $500(.193/.235) = 410.6$ (use 410.)
 Central value $k_s = 500(.193/.250) = 386$.

Fig. 6.10-Method of computing coupled k_s

different results are obtained using 3B versus 10B in an elastic system, therefore, a suggested value of 4B may be sufficiently accurate.

Table 6.1 provides values at the 1/8 points for several mat plans which can be used directly or with linear interpolation for other mat shapes.

2. Numerically integrate the vertical stress profile to obtain the average pressure DQ . Designate the edge value as DQ_e .

3. Compute k_s at any point i (refer to Fig. 6.10) as

$$k_{si} = k_s (DQ_e/DQ_i) \quad (6-8)$$

Table 6.1-Vertical pressure profiles by Newmark's 1935 method (in Bowles 1985) for selected points beneath a foundation as shown

$B/L = 1$

| PRESSURE PROFILE FOR POINTS: | | | | | |
|------------------------------|-------|-------|-------|-------|-------|
| DY | 1 | 2 | 3 | 4 | 5 |
| 0.00 B | 1.000 | 1.000 | 1.000 | 1.000 | 1.000 |
| 0.50B | 0.400 | 0.530 | 0.628 | 0.683 | 0.701 |
| 1.00B | 0.240 | 0.278 | 0.309 | 0.329 | 0.336 |
| 1.50B | 0.146 | 0.160 | 0.170 | 0.177 | 0.179 |
| 2.00B | 0.095 | 0.100 | 0.105 | 0.107 | 0.108 |
| 2.50B | 0.066 | 0.068 | 0.070 | 0.071 | 0.072 |
| 3.00B | 0.048 | 0.049 | 0.050 | 0.050 | 0.051 |
| 3.50B | 0.036 | 0.037 | 0.037 | 0.038 | 0.038 |
| 4.00B | 0.028 | 0.028 | 0.029 | 0.029 | 0.029 |
| AVERAGE PRESSURE INCREASE | | | | | |
| DQ = | 0.193 | 0.217 | 0.235 | 0.246 | 0.250 |

$B/L = 2$

| PRESSURE PROFILE FOR POINTS: | | | | | |
|------------------------------|-------|-------|-------|-------|-------|
| DY | 1 | 2 | 3 | 4 | 5 |
| 0.00B | 1.000 | 1.000 | 1.000 | 1.000 | 1.000 |
| 0.50B | 0.408 | 0.648 | 0.757 | 0.792 | 0.800 |
| 1.00B | 0.270 | 0.362 | 0.431 | 0.469 | 0.481 |
| 1.50B | 0.186 | 0.229 | 0.263 | 0.285 | 0.293 |
| 2.00B | 0.135 | 0.157 | 0.175 | 0.186 | 0.190 |
| 2.50B | 0.101 | 0.113 | 0.123 | 0.129 | 0.131 |
| 3.00B | 0.078 | 0.085 | 0.090 | 0.094 | 0.095 |
| 3.50B | 0.061 | 0.066 | 0.069 | 0.071 | 0.072 |
| 4.00B | 0.049 | 0.052 | 0.054 | 0.056 | 0.056 |
| AVERAGE PRESSURE INCREASE | | | | | |
| DQ = | 0.220 | 0.273 | 0.304 | 0.319 | 0.324 |

$B/L = 3$

| PRESSURE PROFILE FOR POINTS: | | | | | |
|------------------------------|-------|-------|-------|-------|-------|
| DY | 1 | 2 | 3 | 4 | 5 |
| 0.00B | 1.000 | 1.000 | 1.000 | 1.000 | 1.000 |
| 0.50B | 0.409 | 0.718 | 0.796 | 0.811 | 0.814 |
| 1.00B | 0.274 | 0.408 | 0.486 | 0.517 | 0.525 |
| 1.50B | 0.195 | 0.262 | 0.312 | 0.340 | 0.348 |
| 2.00B | 0.147 | 0.185 | 0.216 | 0.235 | 0.241 |
| 2.50B | 0.115 | 0.138 | 0.157 | 0.170 | 0.174 |
| 3.00B | 0.092 | 0.107 | 0.119 | 0.127 | 0.130 |
| 3.50B | 0.075 | 0.085 | 0.093 | 0.098 | 0.100 |
| 4.00B | 0.062 | 0.069 | 0.075 | 0.078 | 0.079 |
| AVERAGE PRESSURE INCREASE | | | | | |
| DQ = | 0.230 | 0.305 | 0.340 | 0.355 | 0.359 |

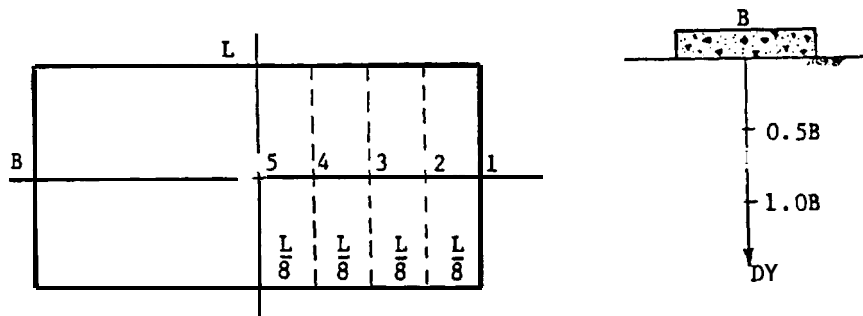

The furnished value of k_s is taken for the mat perimeter zone.

4. Assign values of k_{s_i} in the interior as practical for

the gridding scheme used for the mat. When doing this take into account how the nodal springs will be computed (refer to Fig. 6.8 and 6.10).

6.8-Consolidation settlement

Consolidation settlement and recompression of heave can be incorporated into the mat analysis in an approximate manner as follows:

1. Compute the estimated consolidation settlements ΔH_{ci} at the several points as used for the coupling analysis. This must also be done for the edge.

2. Make a basic mat analysis (including coupling if this is going to be the method used). Inspect output for edge pressures and obtain a best estimate of the edge-pressure average. Also obtain node displacements ΔH_i and estimate node consolidation displacements ΔH_{ci} . The revised k'_{si} can be computed from the basic definitions of k_s

$$q_i = k_{st} (\Delta H_i) \text{ and } k'_{st} = q_i / (\Delta H_i + \Delta H_{ci})$$

to obtain

$$k'_{st} = k_{si} (\Delta H_i) / (\Delta H_i + \Delta H_{ci}) \quad (6-9)$$

3. Run the mat analysis with these new zoned values of k'_{si} . Output will include effect of consolidation settlement. Edge nodes should compute a displacement approximately equal to the computed consolidation settlement from Step 2.

The problem may be cycled several times since the consolidation settlement computed depends on the mat contact pressure, which may change as computations progress.

Since the consolidation settlement is time-dependent it may be appropriate (depending on time for consolidation) to use a reduced value of E_c for the concrete to allow for creep effects,

6.9-Edge springs for mats

An alternative to using the Boussinesq coupling procedure is to double the exterior edge springs (but not any along edges of symmetry where a part of the mat is analyzed). This doubling will include some coupling effect and account somewhat for the higher theoretical edge pressures claimed to develop in cohesive soils beneath rigid plates. Doubling of springs for a plate with a single column (as a spread footing) tends to give computed differences of less than 10 percent for moments at the column faces.

Doubling of springs for mats can give differences between computer-generated values as much as 20 percent larger with the higher values obtained from doubling. A Committee comparison using the FGM and the mat given by Shukla (1984) showed that doubling the edge springs produced computed moments about 18 to 25 percent higher and that the larger moments gave a better comparison to the values computed by hand in that reference.

It should be noted, however, that doubling the edge springs tends towards the same end result as using the Boussinesq coupling procedure, since the reduction of the interior values of k_s for a mat is similar to increasing the soil resistance at the edge.

In order of increasing difficulty, the suggested procedures are:

1. Using direct area contributions for all springs (common practice but not correct, as stated previously).

2. Doubling the edge springs (not strictly correct, but not very difficult to program a routine in a mat program).

3. Using the Boussinesq coupling of Section 6.7. This is the most accurate of the approximate procedures, but is also more difficult. Some difficulty can be reduced by programming a routine for most of the mechanical steps.

4. Using Methods 2 and 3 in combination.

6.10-Computer output

The computer program for any of the three methods (finite difference [FD], finite grid method [FGM], or finite element method [FEM]) should output:

1. X and Y bending moment summations at all nodes so that a statics check can be quickly made at points where this summation should be zero.

2. The displacement matrix. This should be routinely checked for any symmetry and points of known displacements (if any).

3. Nodal soil reactions (forces) computed as

$$\text{Force} = \text{Node spring} \times \text{Displacement} \quad (6-10)$$

The node forces should be computed, summed, and compared to the sum of the vertical input forces (column loads and mat weight). Routinely check this to within computer roundoff.

4. Nodal soil pressures computed as:

$$q_i = k_i \times \text{Displacement} \quad (6-11)$$

The node pressures q should not exceed the value recommended by the geotechnical engineer. If the program considers nonlinear effects, both the node force and node pressure is limited to some maximum value. Verify that the program uses this by inspecting the displacements larger than the limiting value (and any that indicate soil separation).

If a program is reasonably complete in providing the above output, the designer can make a rapid check of the computations. A check of the mat data (node coordinates, etc.) will usually take much longer; however, the check may identify that some input is bad if the computed output is grossly in error. Where errors might occur, a user should modify the program to print (on demand) the full stiffness matrix (in blocks so the pages can be cut and pasted) to display the matrix for inspection of symmetry. Since the stiffness matrix is always symmetrical and has no zeroes on the diagonal, this provides a good check on the internal programming used to develop the stiffness matrix. While this check produces a large amount of paper output, the paper cost is negligible compared to a design error.

6.11-Two-dimensional or three-dimensional analysis

A mat designed as a plate on an elastic foundation using soil concentrations at the nodes is considered a two-dimensional analysis (2-D). If the mat is placed on the soil and the soil is modeled using three-dimensional solids, the analysis is termed three-dimensional (3-D).

A 3-D analysis is extremely costly in modeling time and use of computer resources. At present, computer programs are not widely available to model the soil as a 3-D continuum and most use has been for nuclear power plants.

Since any mat analysis is only as good as the soil parameters, it is usually difficult to justify a 5 to 10 percent computational difference when the soil parameters may only be estimates or a range of values. This is particularly true if:

a. 3-D analysis cost is four or five times that of a 2-D analysis.

b. Design personnel are not particularly familiar with the program or methodology.

The major appeal of a 3-D analysis is for soil coupling. Since coupling can be handled within the precision of the soil response prediction as outlined in [Section 6.7](#), there is little to justify use of a 3-D mat analysis.

6.12-Mat thickness

The FD and FEM methods imply use of thin plate theory. While an investigator may question whether a 5-ft (1.8 m) mat is a thin plate, a thin plate analysis is generally used and is adequate. The FGM method makes no assumption on plate thickness but analyzes what is given.

A comparison study by Frederick (1957) showed that a plate would have to be quite thick to invalidate the "thin" plate theory model.

6.13-Parametric studies

It is very difficult for the geotechnical engineer to provide accurate elastic design parameters for the soil (E_s , μ , and k_s). Recognizing this, the structural designer and geotechnical engineer may do a parametric study, varying the value of over a range of one-half the furnished value to five or ten times the furnished value.

The results of the parametric study should be reviewed by the geotechnical engineer during the course of the design. If no satisfactory solution is found, then adjustments in the development concept may be appropriate. Adjustments may include: reducing the weight of the structure (change from reinforced concrete to structural steel), enlarging the mat in plan, or deepening the mat base to reduce the net applied pressure. Such adjustments should be made only with the concurrence of the geotechnical engineer.

6.14-Mat foundation detailing/construction

To simplify steel placement, it is common practice to provide a layer of top and bottom reinforcement in

both directions. As localized flexure requirements dictate, additional reinforcement is placed in the same layer, or as additional layers to add strength to the section. It is essential that the engineer prepare thorough drawings documenting all phases of the reinforcement placement. Splice locations must be shown and lengths noted. Specification of placement sequence is very important. To insure structural integrity, short staggered lap splices should be used instead of long splices occurring at one location. On large jobs, No. 14 and No. 18 bars may be used to minimize the number of pieces on the job and to reduce the quantity of bar layers.

CHAPTER 7-SUMMARY

The recommendations given in Chapters 1 through 6 may be used as a guide in analysis and design of combined footings (two or more columns in a line) or mat foundations. These recommendations represent the collective opinion of the Committee members based on both practice and a survey of published literature. The Committee recognizes that it is impossible to cover all foundation cases likely to be encountered by a designer and no attempt has been made to do this.

The Committee recognizes that the state of the art in computerized analyses is substantially ahead of the ability of engineers to determine soil properties accurately. The use of computer methods is recommended since they allow parametric studies so that a range of possible (or probable) soil responses can be investigated.

The Committee concedes that the Winkler foundation model can be improved, but the increased computational complexity is not warranted when soil properties are taken into account. For this reason the simple coupling procedure outlined here which relies on the widely used Boussinesq theory will generally be adequate if some additional computational refinement is wanted.

Computer analyses are generally more efficient than hand computations - particularly of the beam-on-elastic-foundation type since interpolation of table or curve values is eliminated. This statement also recognizes the current widespread availability of desk-top to main-frame computer systems.

Finally, the Committee notes that, with the same care and attention to detail, the real advantage of the computer approach is the ability to better capture the effects of irregular geometry and foundation flexibility. The keywords are "with the same care." The analysis and design of a mat foundation is a problem in soil-structure interaction requiring a close working relationship between the structural and geotechnical engineer. Although published values of soil response parameters are available, geotechnical engineering analysis and judgement are needed to make the values meaningful to the design.

CHAPTER 8--REFERENCES

8.1 -Specified and/or recommended references

American Concrete Institute

318-83 Building Code Requirements for
(Revised 1986) Reinforced Concrete

8.2 -Cited references

- ACI Committee 336, 1966, "Suggested Design Procedures for Combined Footings and Mats," American Concrete Institute. Detroit, 13 pp.
- Ball, Steven C., and Notch, James S., May 1984, "Computer Analysis/Design of Large Mat Foundations," *Journal of Structural Engineering*, ASCE, V. 110, No. 5, pp. 1180-1196.
- Banavalkar, P. V., and Ulrich, E. J., Jr., 1984, "Republic Bank Center: Structural and Geotechnical Features," International Conference on Tall Buildings, Singapore, Oct.
- Bowles, Joseph E., 1974, *Analytical and Computer Methods in Foundation Engineering*, McGraw-Hill Book Co., New York, pp. 154, 155, and 168-170.
- Bowles, Joseph E., 1975, "Spread Footings," *Foundation Engineering Handbook*, Van Nostrand Reinhold Co., New York. Chapter 15, pp. 490-491.
- Bowles, Joseph E., 1976, "Mat Foundations" and "Computer Analysis of Mat Foundations," *Proceedings*, Short Course-Seminar on Analysis and Design of Building Foundations (Lehigh University), Envo Press, Lehigh Valley, pp. 209-232 and 233-256.
- Bowles, Joseph E., 1982, *Foundation Analysis and Design*, 3rd Edition, McGraw-Hill Book Co., New York, 800 pp.
- Bowles, Joseph E., 1983, "Pile Cap Analysis," *Proceedings*, 8th Conference on Electronic Computation (Houston), American Society of Civil Engineers, New York, pp. 102-113.
- Bowles, Joseph E., 1984, *Physical and Geotechnical Properties of Soil*, 2nd Edition, McGraw-Hill Book Co., New York, 1984, Chapter 10.
- Christian, J. T., 1976, "Soil-Foundation-Structure Interaction," *Proceedings*, Short Course-Seminar on Analysis and Design of Building Foundations (Lehigh University), Envo Press, Lehigh Valley, pp. 149-179.
- Collatz, L., 1960, *The Numerical Treatment of Differential Equations*, 3rd Edition, Springer-Verlag, Berlin.
- Cook, R. D., 1974, *Concepts and Applications of Finite Element Analysis*, John Wiley & Sons, New York, 402 pp.
- Department of the Navy, 1982, "Soil Mechanics," *Design Manual NAVFAC DM-7.1*, Naval Facilities Engineering Command, Alexandria, pp. 7.1-161 - 7.1-241.
- Department of the Navy, 1982, "Foundations and Earth Structures," *Design Manual NAVFAC DM-7.2*, Naval Facilities Engineering Command, Alexandria, pp. 7.2-129 - 7.2-159.
- Focht, John A., Jr.; Khan, Fazlur, R.; and Gemeinhardt, J. Peter, May 1978, "Performance of One Shell Plaza Deep Mat Foundation," *Proceedings*, ASCE, V. 104, GT5, pp. 593-608.
- Frederick, Daniel, 1957, "Thick Rectangular Plates on an Elastic Foundation," *Transactions*, ASCE, V. 122, pp. 1069-1085. Also, see Discussion, p. 1086, which corrects conclusions presented in paper.
- Ghali, A., and Neville, A. M., 1972, *Structural Analysis: A Unified Classical and Matrix Approach*. Intext Educational Publishers (Now Harper and Row), Chapters 17-20.
- Haddadin, M. J., 1971, "Analysis and Design of Foundation Mats and Combined Footings-Program User's Manual," Portland Cement Association, Skokie. 55 pp.
- Hetenyi, M., 1946, *Beams on Elastic Foundation*. University of Michigan Press, Ann Arbor, pp. 100-106.
- Kramrisch, Fritz, and Rogers, Paul, Oct. 1961, "Simplified Design of Combined Footings," *Proceedings*, ASCE, V. 88, SM5, pp. 19-44.
- Kramrisch, Fritz, 1984, "Footings," *Handbook of Concrete Engineering*, 2nd Edition. Mark Fintel. Editor, Van Nostrand Reinhold Co., New York, pp. 139-168.
- Meyerhof, G. G., June 1953, "Some Recent Foundation Research and its Application to Design," *The Structural Engineer* (London), V. 31, No. 6.
- Newmark, N. M., 1935, "Simplified Computation of Vertical Pressures in Elastic Foundations," *Experiment Station Circular No. 24*, University of Illinois, Urbana.
- Schleicher, Ferdinand, 1926, *Kreisplatten auf elastischer Unterlage*, Jules Springer, Berlin.
- Scott, R. F., 1981, *Foundation Analysis*, Prentice-Hall, Inc., Englewood Cliffs, pp. 150-197.
- Shukla, Shyam N., Sept.-Oct. 1984, "A Simplified Method for Design of Mats on Elastic Foundations," *ACI JOURNAL*, *Proceedings* V. 81, No. 5, pp. 469-475.
- Sowers, G. F., 1977, "Foundation Modulus for a Mat on Sand," *Preprint No. 29371*, American Society of Civil Engineers, New York.
- Teng, Wayne Chi-Yu, 1962, *Foundation Design*, Prentice-Hall, Inc., Englewood Cliffs, pp. 174-191.
- Terzaghi, K., Dec. 1955, "Evaluation of Coefficients of Subgrade Reaction," *Geotechnique* (London), V. 5, No. 4, pp. 297-326.
- Timoshenko, S., and Woinowsky-Krieger, S., 1959, *Theory of Plates and Shells*, 2nd Edition, McGraw-Hill Book Co., New York, pp. 259-281.
- Ulrich, E.J., 1988, "Geotechnical Considerations in Mat Foundation Design," *Structural and Geotechnical Lecture Series*, Illinois section, ASCE, Chicago.
- Ulrich, E. J., and Focht, J. A., 1982, "First City National Bank to Texas Commerce Tower: Lessons Learned," *Preprint No. 82-532*, ASCE National Convention (New Orleans), American Society of Civil Engineers, New York.
- U.S. Department of the Interior, 1960, "Moments and Reactions for Rectangular Plates," *Engineering Monograph No. 27*, Bureau of Reclamation, Denver.
- Winterkorn, Hans F., and Fang, Hsai-Yang, 1975, *Foundation Engineering Handbook*, Van Nostrand Reinhold Co., New York, pp. 481-555.
- Zienkiewicz, O. C., 1977, *The Finite Element Method*, 3rd Edition, McGraw-Hill Book Co., New York, 808 pp.

¹This report was submitted to letter ballot of the committee and was approved according to ACI balloting procedures.