

Flexible & Rigid Pavements

History

- In its most general sense, a road is an open, generally public way for the passage of vehicles, people, and animals.
- The earliest human road builders predate recorded history by thousands of years. With the advent of modern man, road building - the purposeful construction of general public ways - became a common sign of an advancing civilization.
- Covering these roads with a hard smooth surface (pavement) helped make them durable and able to withstand traffic and the environment. Some of the oldest paved roads still in existence were built by the Roman Empire.

Roman Roads



- By in large, Roman roads (see Figure) were constructed during the Republican times - the oldest road, Via Appia, dates back to 312 B.C.
- The Roman road network consisted of over 100,000 km (62,000 miles) of roads.
- The superior quality and structure of its pavements have allowed many Roman roads to survive to this day.

... Roman Roads

A typical Roman road structure (see Figure), as seen in the United Kingdom, consisted of four basic layers (Collins and Hart, 1936):

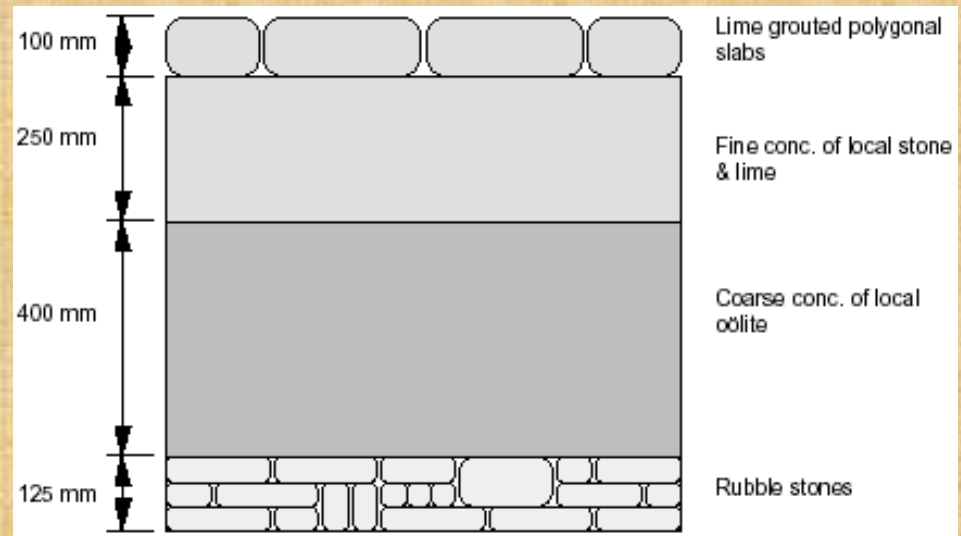

- **Summa Crusta (surfacing).** Smooth, polygonal blocks embedded in the underlying layer.
- **Nucleus.** A kind of base layer composed of gravel and sand with lime/cement.
- **Rudus.** The third layer was composed of rubble masonry and smaller stones also set in lime mortar.
- **Statumen.** Two or three courses of flat rubble stones set in lime mortar.

Telford Pavements

- The first insight into today's modern pavements can be seen in the pavements of Thomas Telford (born 1757). Telford served as a building mason (Smiles, 1904) and extended his masonry knowledge to bridge building. During lean times, he carved grave-stones and other ornamental work (about 1780).
- Eventually, Telford became the "Surveyor of Public Works" for the county of Salop (Smiles, 1904), thus turning his attention more to roads. Telford attempted, where possible, to build roads on relatively flat grades (no more than a 1 in 30 slope) in order to reduce the number of horses needed to haul cargo.

... Telford Pavements

Telford's pavement section was about 350 to 450 mm (14 to 18 inches) in depth and generally specified three layers. The bottom layer was comprised of large stones 100 mm (4 inches) wide and 75 to 180 mm (3 to 7 inches) in depth (Collins and Hart, 1936). It is this specific layer which makes the Telford design unique (Baker, 1903). On top of this were placed two layers of stones of 65 mm (2.5 inches) maximum size about 150 to 250 mm (6 to 9 inches) total thickness) followed by a wearing course of gravel about 40 mm (1.6 inches) thick (see Figure). It was estimated that this system would support a load corresponding to about 88 N/mm (500 lb per in. of width).

... Telford Pavements

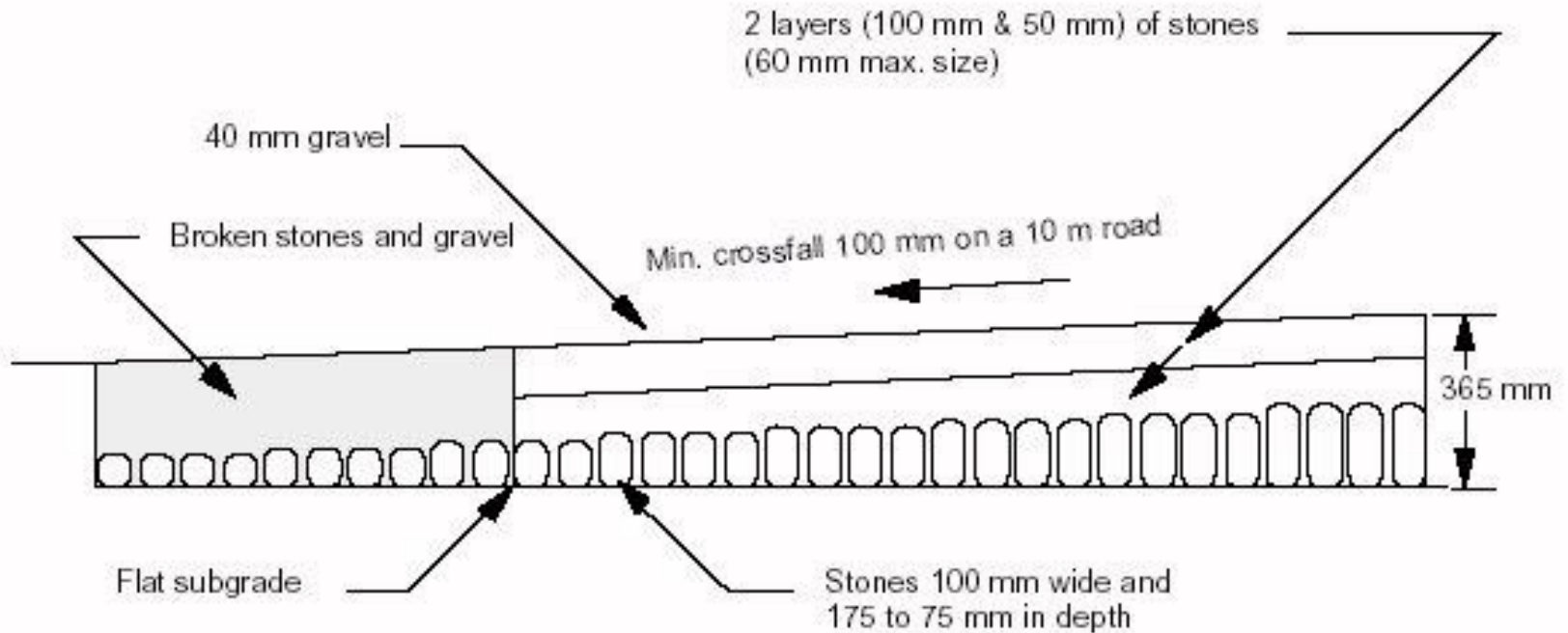

Macadam Pavements

- Macadam pavements introduced the use of angular aggregates. John MacAdam (born 1756 and sometimes spelled "Macadam") observed that most of the paved U.K. roads in early the 1800s were composed of rounded gravel (Smiles, 1904).
- He knew that angular aggregate over a well-compacted subgrade would perform substantially better. He used a sloped subgrade surface to improve drainage (unlike Telford who used a flat subgrade surface) on which he placed angular aggregate (hand-broken with a maximum size of 75 mm (3 inches)) in two layers for a total depth of about 200 mm (8 inches) (Gillette, 1906).
- On top of this, the wearing course was placed (about 50 mm thick with a maximum aggregate size of 25 mm) (Collins and Hart, 1936). Macadam's reason for the 25 mm (1 inch) maximum aggregate size was to provide a "smooth" ride for wagon wheels.

... Macadam Pavements

- The total depth of a typical MacAdam pavement was about 250 mm (10 inches) (refer to Figure).
MacAdam was quoted as saying "no stone larger than will enter a man's mouth should go into a road" (Gillette, 1906). The largest permissible load for this type of design has been estimated to be 158 N/mm (900 lb per in. width).
- In 1815, Macadam was appointed "surveyor-general" of the Bristol roads and was then able to use his design on numerous projects. It proved successful enough that the term "macadamized" became a term for this type of pavement design and construction.
- The term "macadam" is also used to indicate "broken stone" pavement (Baker, 1903).

... Macadam Pavements

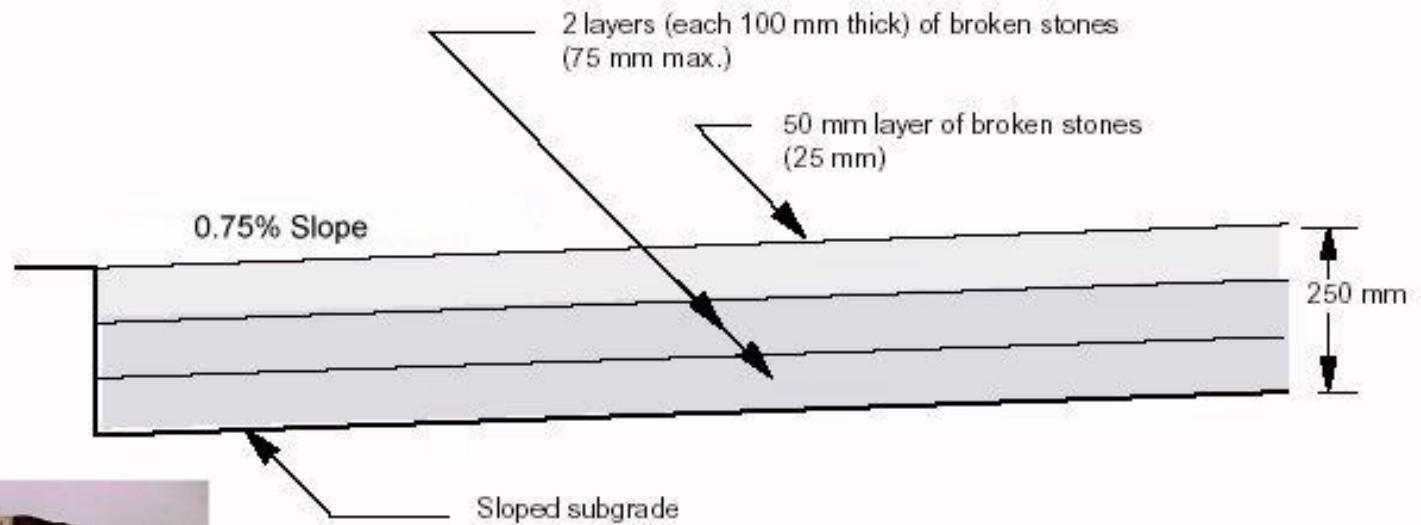



Pavement Overview

- **Pavement Purpose**

Typically, pavements are built for three main purposes:

1. Load support. Pavement material is generally stiffer than the material upon which it is placed, thus it assists the in situ material in resisting loads without excessive deformation or cracking.
2. Smoothness. Pavement material can be placed and maintained much smoother than in situ material. This helps improve ride comfort and reduce vehicle operating costs.
3. Drainage. Pavement material and geometric design can affect quick and efficient drainage thus eliminating moisture problems such as mud and ponding (puddles).

What is a Pavement?

- A multi layer system that distributes the vehicular loads over a larger area

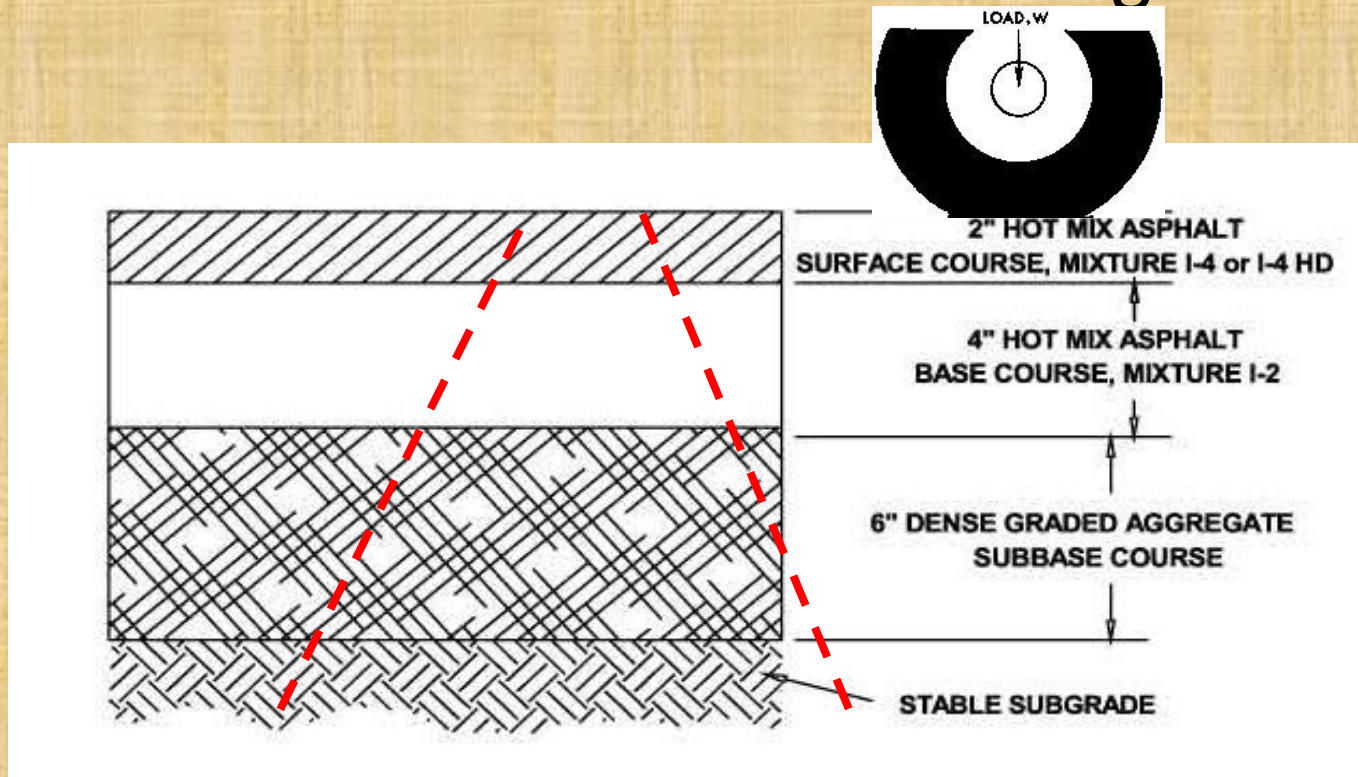

Classification of Pavements

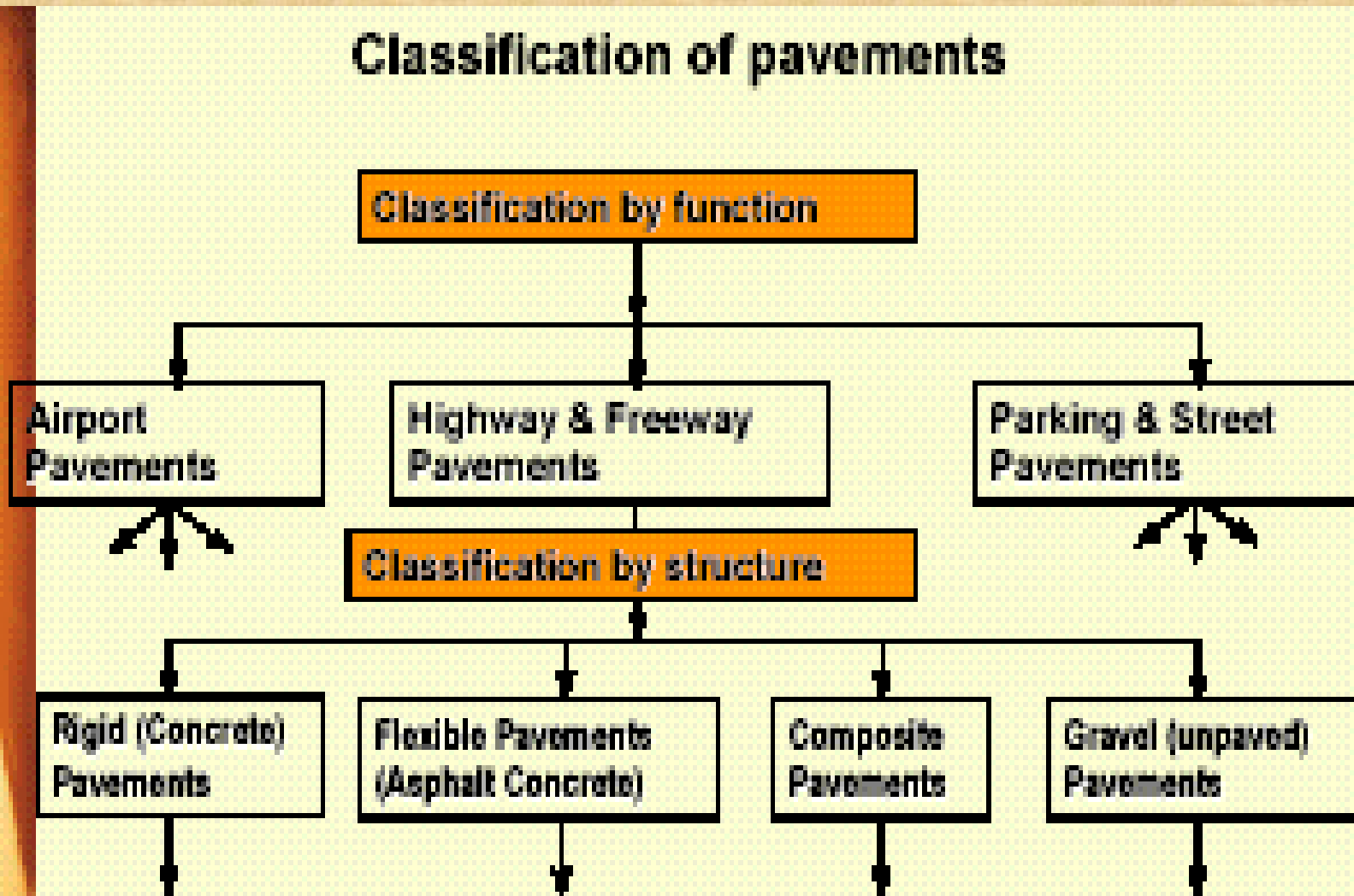

Types of Pavements

Types of pavements

Flexible Pavement: Conventional Components

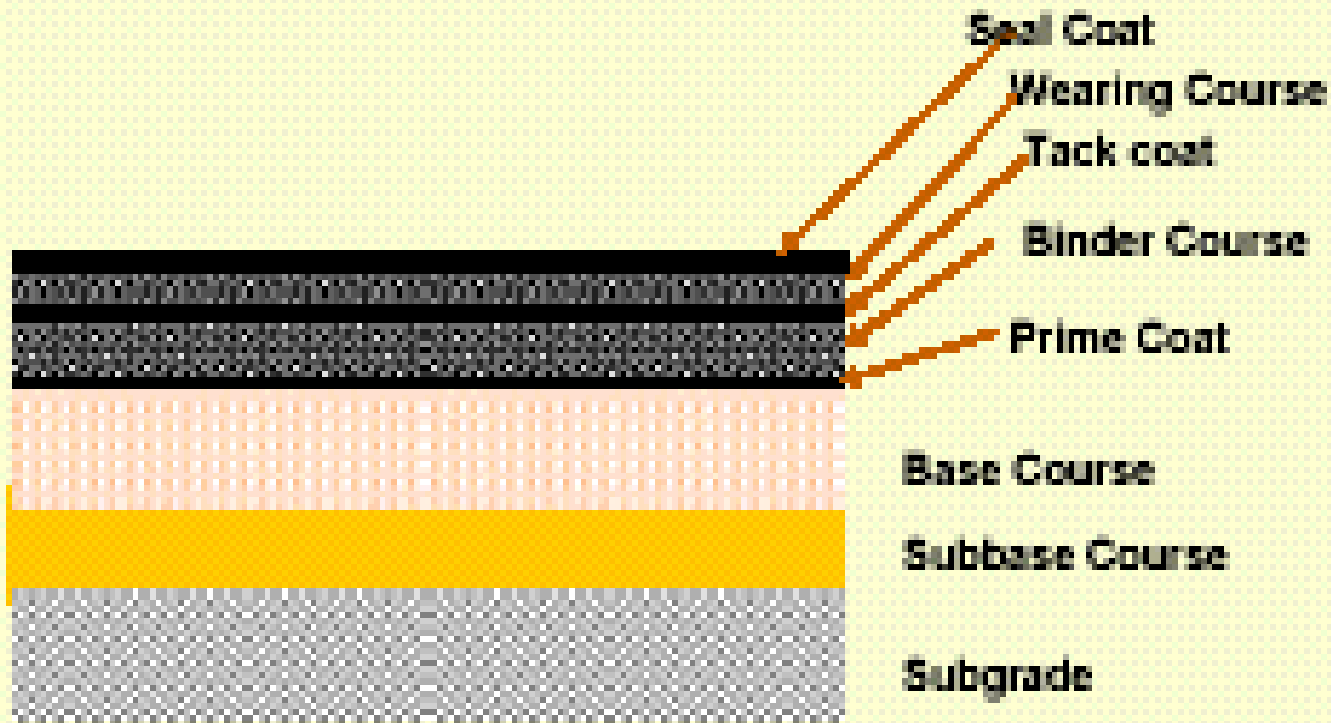

Types of Pavements

Types of Pavements

▣ Typical Flexible Pavements Structure

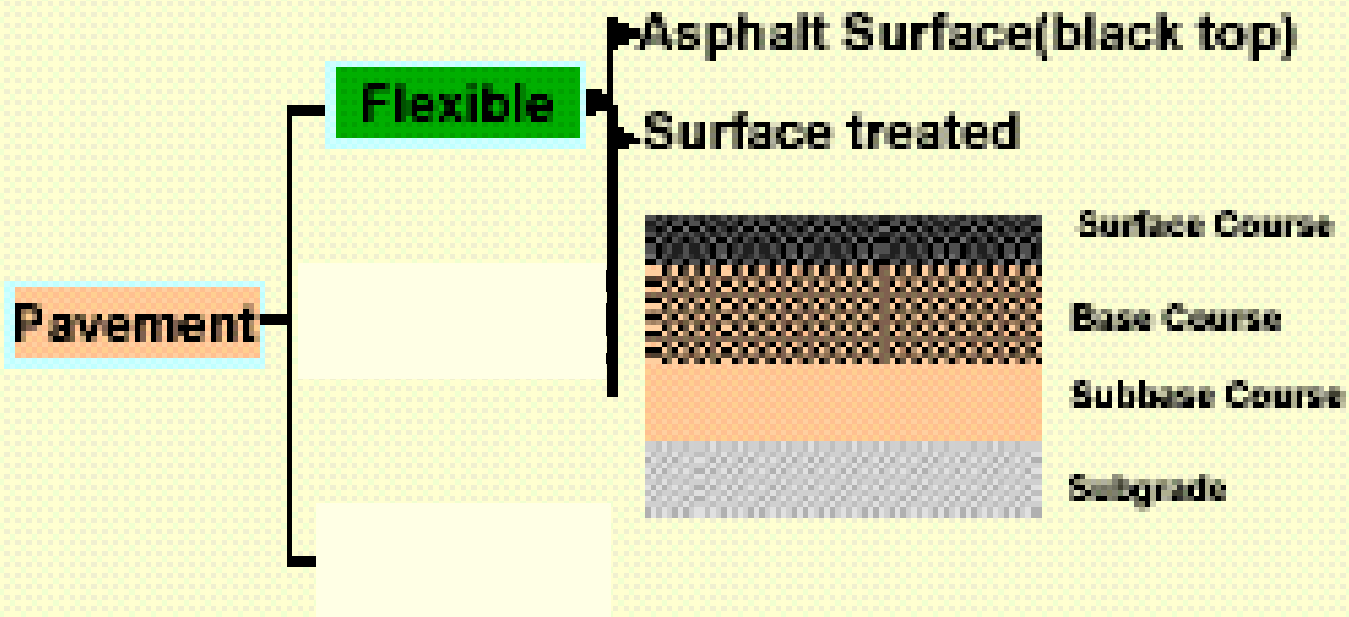

Types of Pavements

Types of Pavements

- Rigid pavements

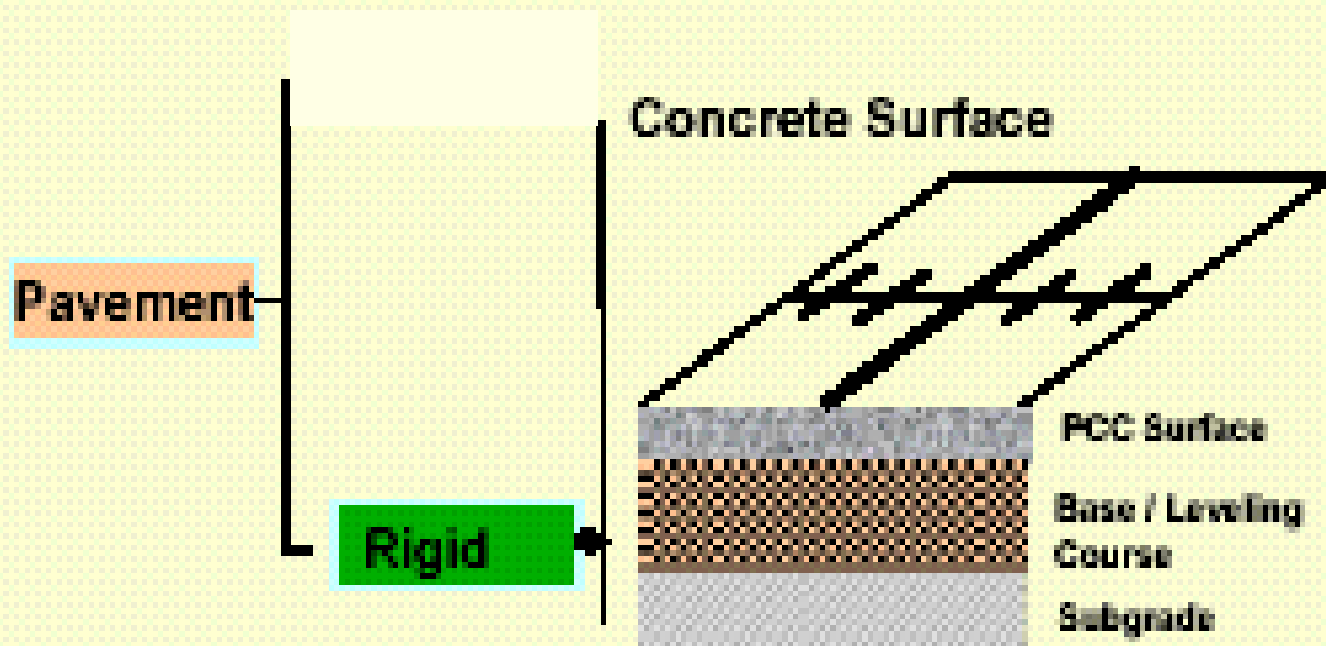

Types of Pavements

- Types of Pavements
 - Composite Pavements

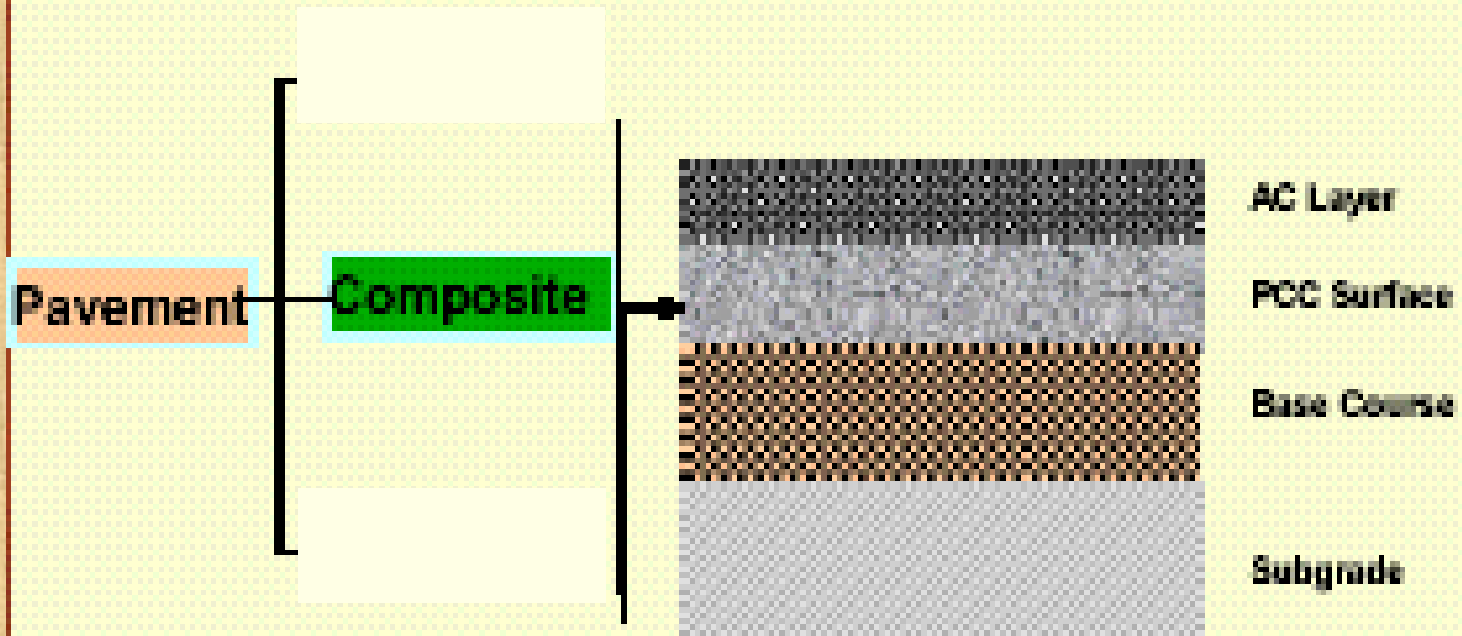

Types of Pavements

Types of Pavements

- Composite pavement (Black topping)

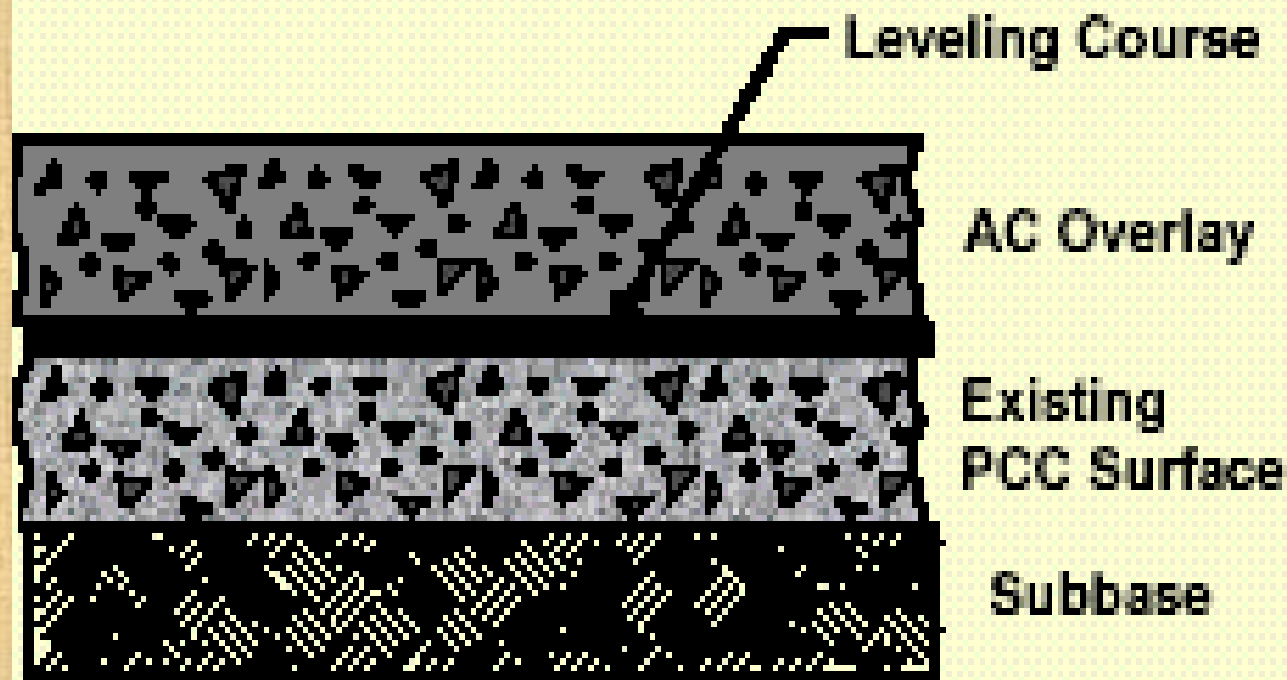

Types of Pavements

Types of Pavements

- Composite pavement (White topping)

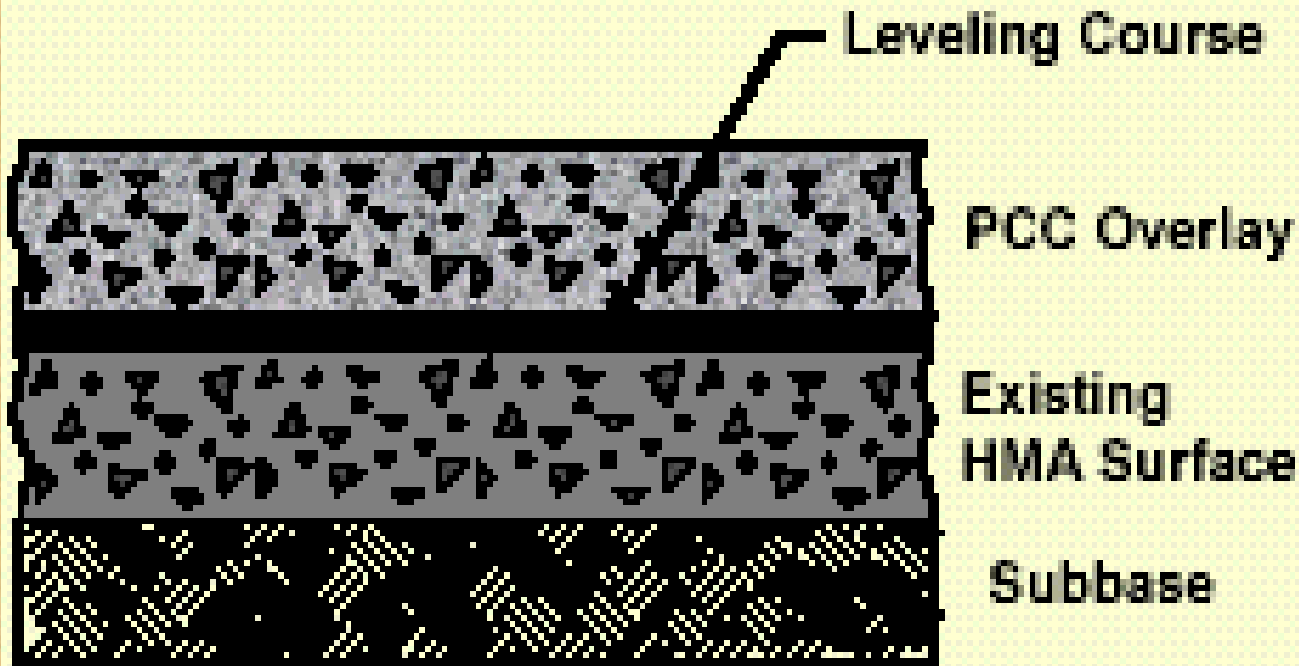

HMA Types

There are many different types of flexible pavements. This section covers three of the more common types of HMA mix types used. This section provides a brief exposure to:

- [Dense-graded HMA](#). Flexible pavement information in this *Guide* is generally concerned with dense-graded HMA. Dense-graded HMA is a versatile, all-around mix making it the most common and well-understood mix type in the U.S.
- [Stone matrix asphalt \(SMA\)](#). SMA, although relatively new in the U.S., has been used in Europe as a [surface course](#) for years to support heavy traffic loads and resist studded tire wear.
- [Open-graded HMA](#). This includes both open-graded friction course (OGFC) and asphalt treated permeable materials (ATPM). Open-graded mixes are typically used as wearing courses (OGFC) or underlying drainage layers (ATPM) because of the special advantages offered by their porosity.

Types of Flexible Pavement



Wheel Load P

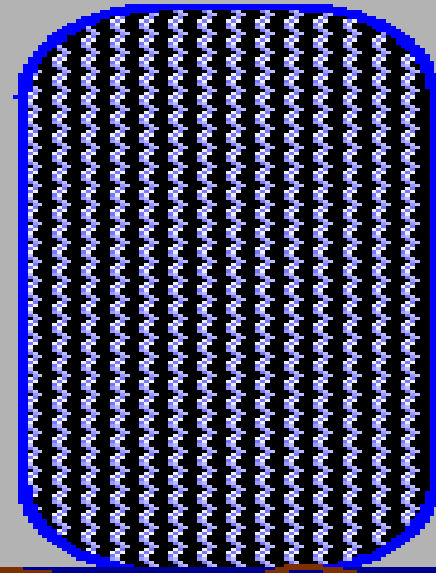

Granular Structure

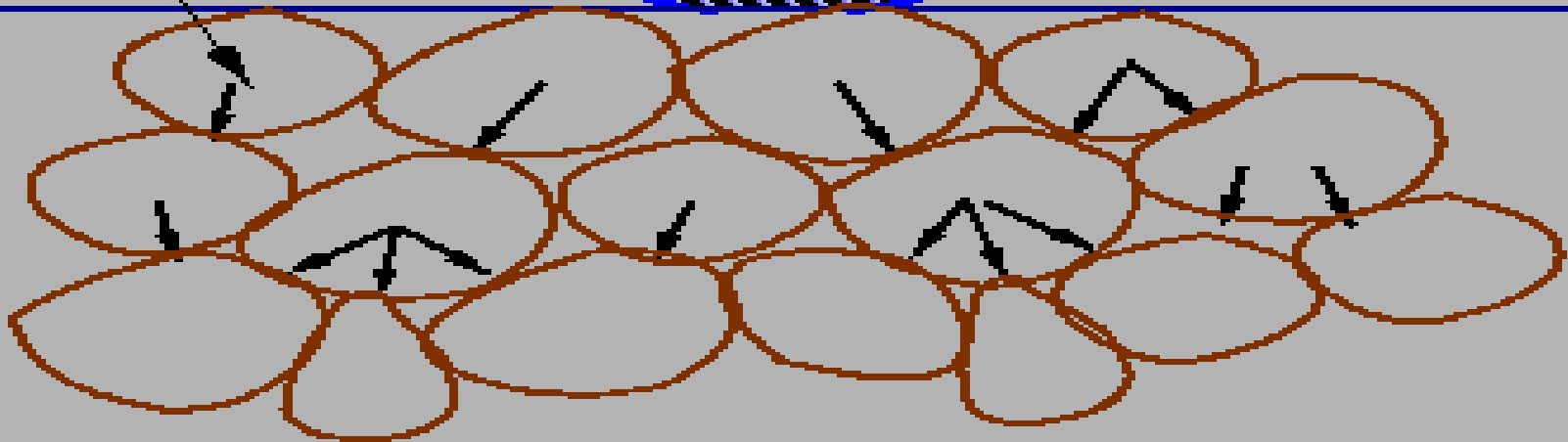

Wheel Load Distribution

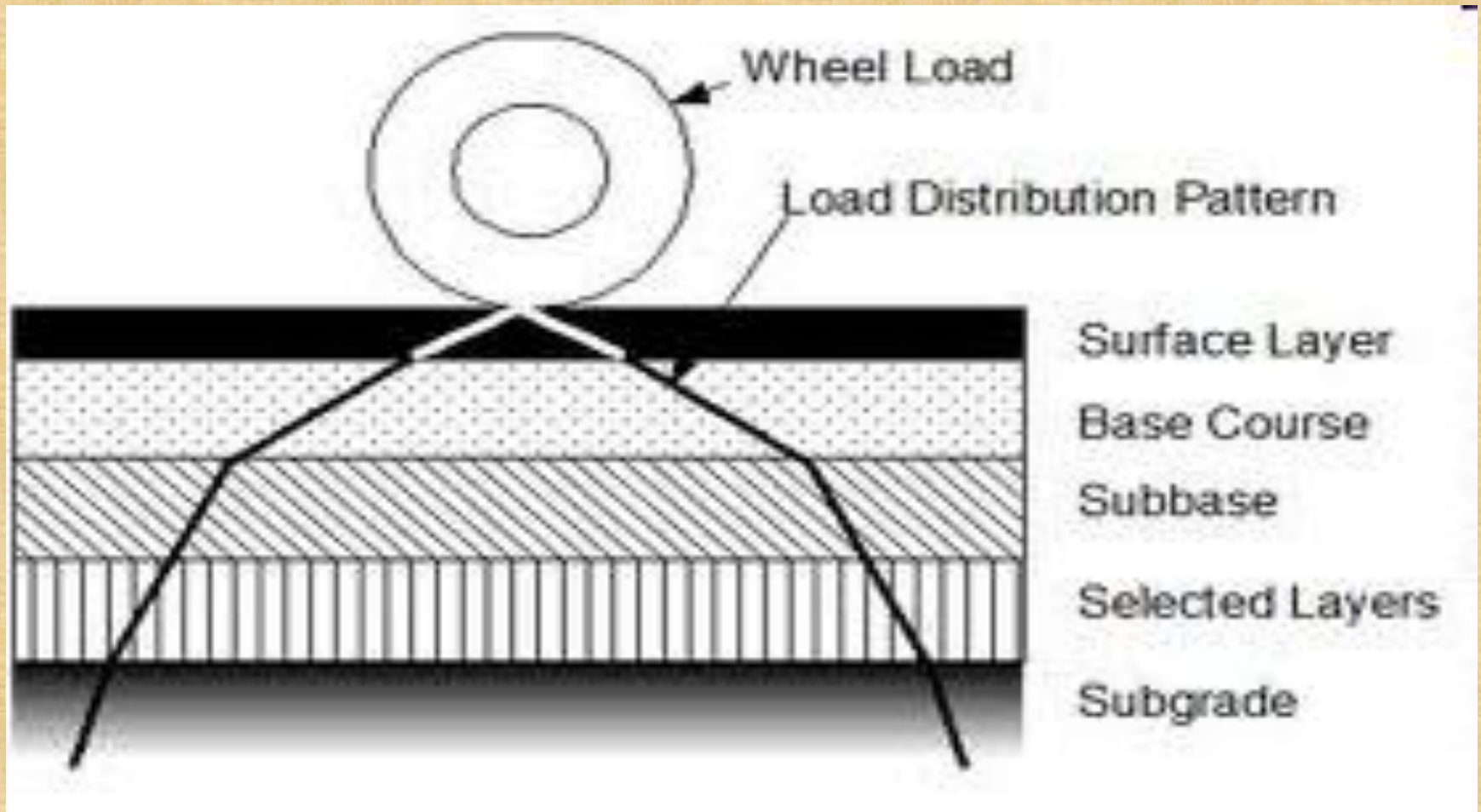

Basic Components of Concrete Pavement

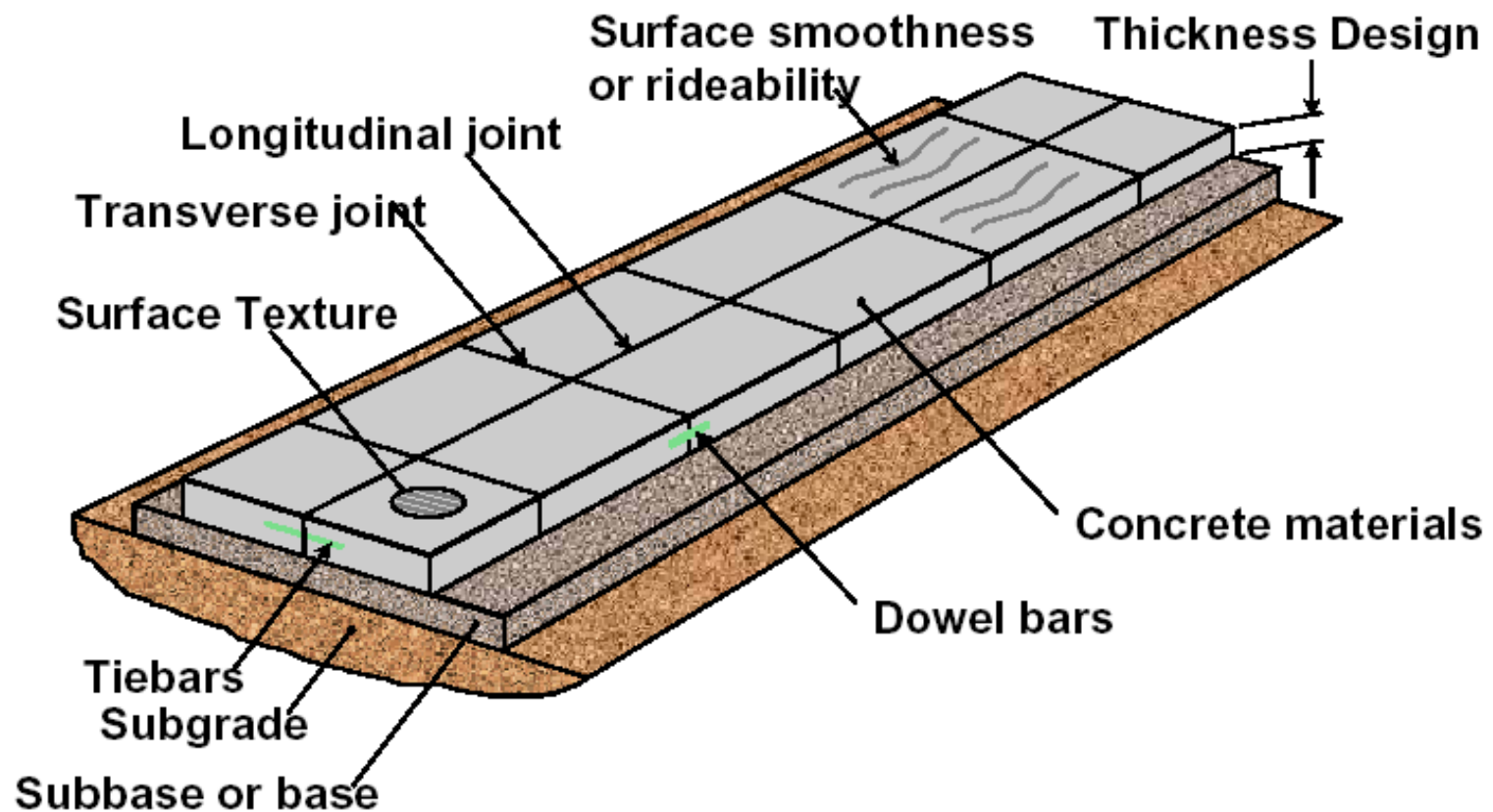

- Jointed Plain Concrete Pavement (JPCP)

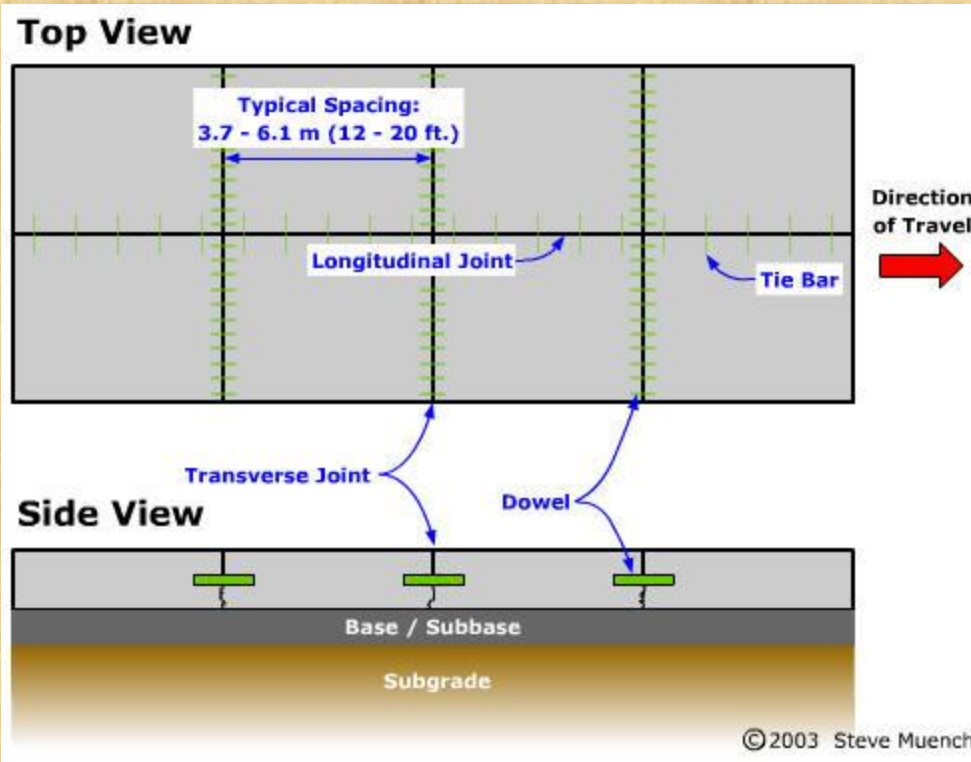

Jointed CC Pavement

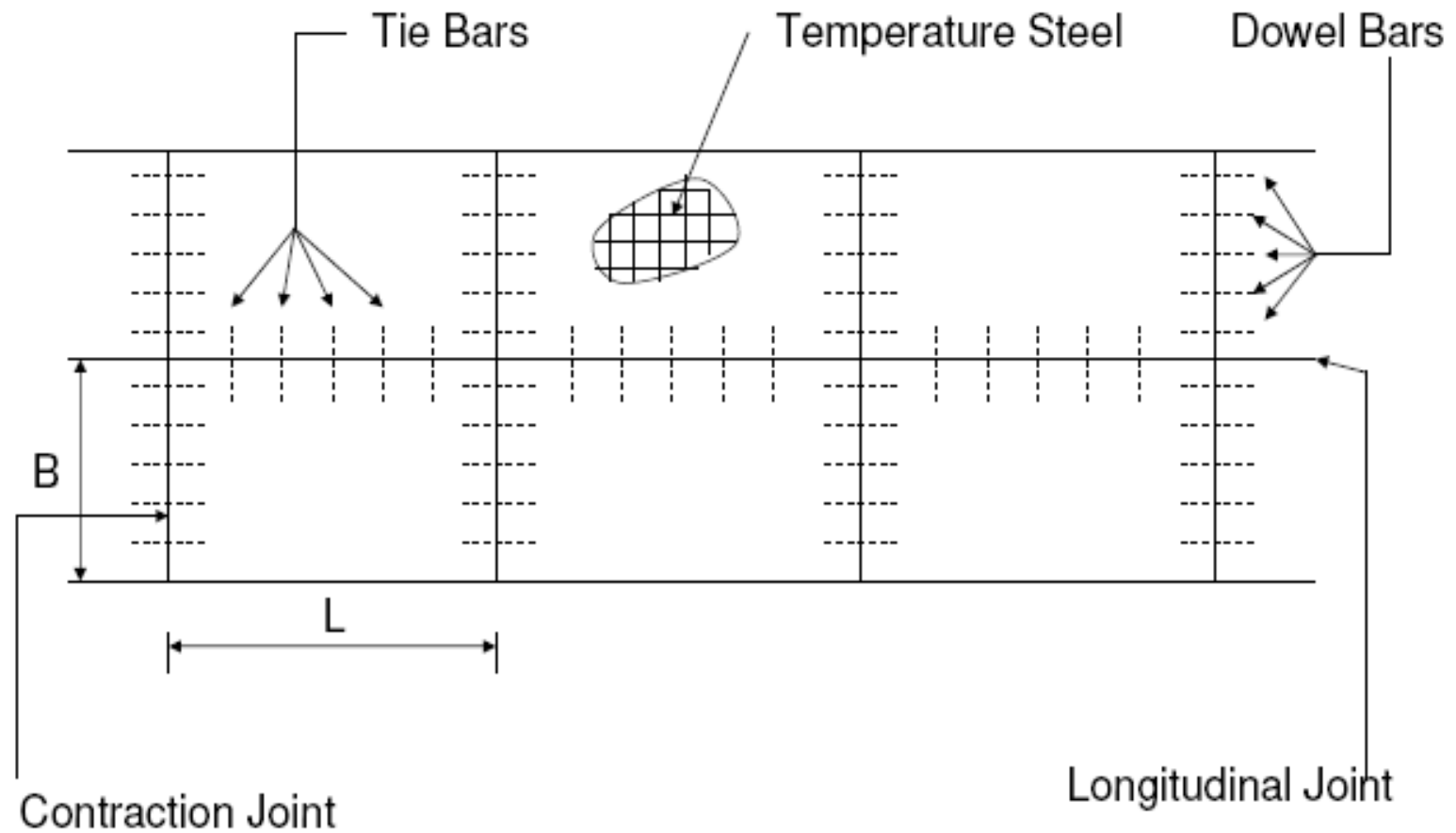

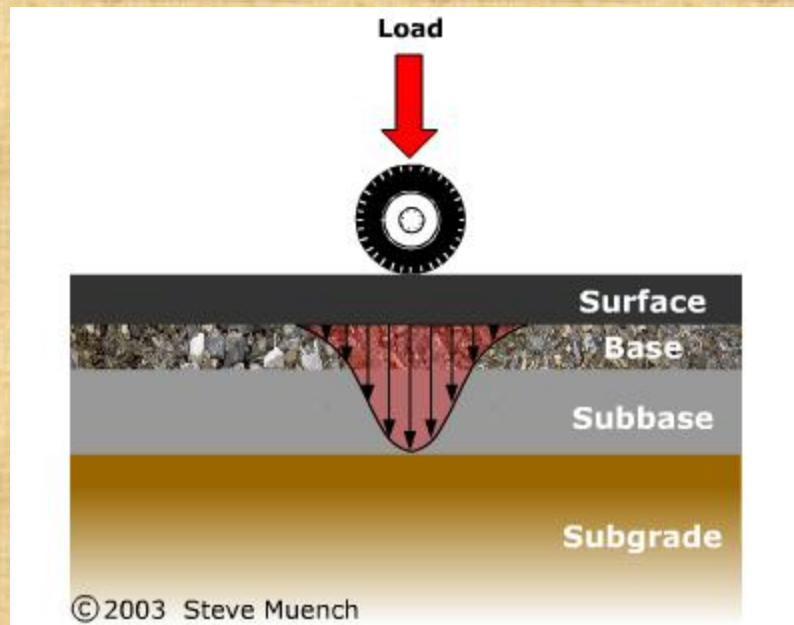
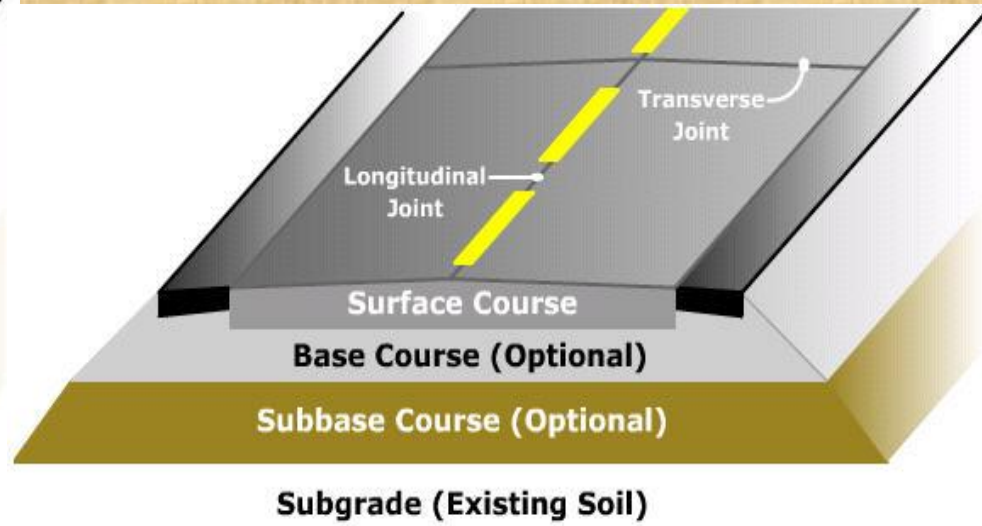
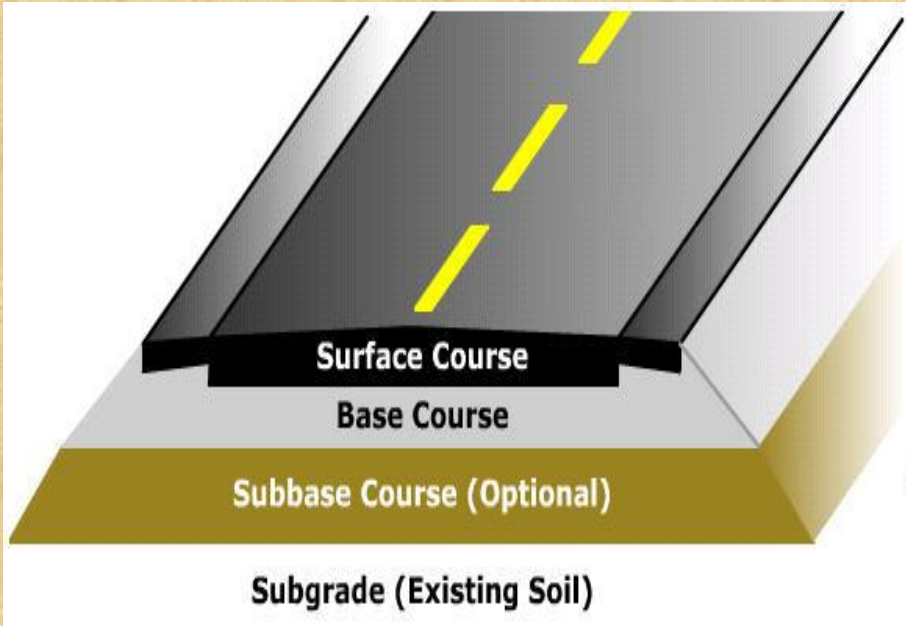

Flexible

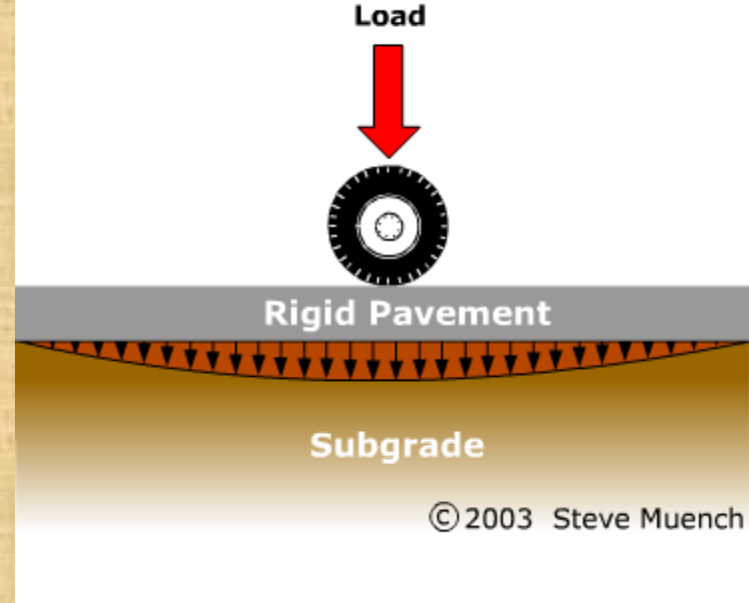

Rigid

Pavements Comparison

Flexible pavements:

- Multi layer construction
- Energy consumption due to transportation of materials
- Increasing cost of asphalt due to high oil prices

Rigid pavements

- Single layer
- Generally last longer
- May require asphalt topping due to noise / comfort issues

Pavements Comparison

- Heavy vehicles consume less fuel on rigid pavements



- Rigid pavements more economic when considering environmental / life-cycle costing

Properties	Flexible	Rigid
Design Principle	Empirical method Based on load distribution characteristics of the components	Designed and analyzed by using the elastic theory
Material	Granular material	Made of Cement Concrete either plain, reinforced or prestressed concrete
Flexural Strength	Low or negligible flexible strength	Associated with rigidity or flexural strength or slab action so the load is distributed over a wide area of subgrade soil.
Normal Loading	Elastic deformation	Acts as beam or cantilever
Excessive Loading	Local depression	Causes Cracks
Stress	Transmits vertical and compressive stresses to the lower layers	Tensile Stress and Temperature Increases
Design Practice	Constructed in number of layers.	Laid in slabs with steel reinforcement.
Temperature	No stress is produced	Stress is produced
Force of Friction	Less. Deformation in the sub grade is not transferred to the upper layers.	Friction force is High
Opening to Traffic	Road can be used for traffic within 24 hours	Road cannot be used until 14 days of curing
Surfacing	Rolling of the surfacing is needed	Rolling of the surfacing is not needed.

Function and Significance of Subgrade Properties

- Basement soil of road bed.
- Important for structural and pavement life.
- Should not deflect excessively due to dynamic loading.
- May be in fill or embankment.

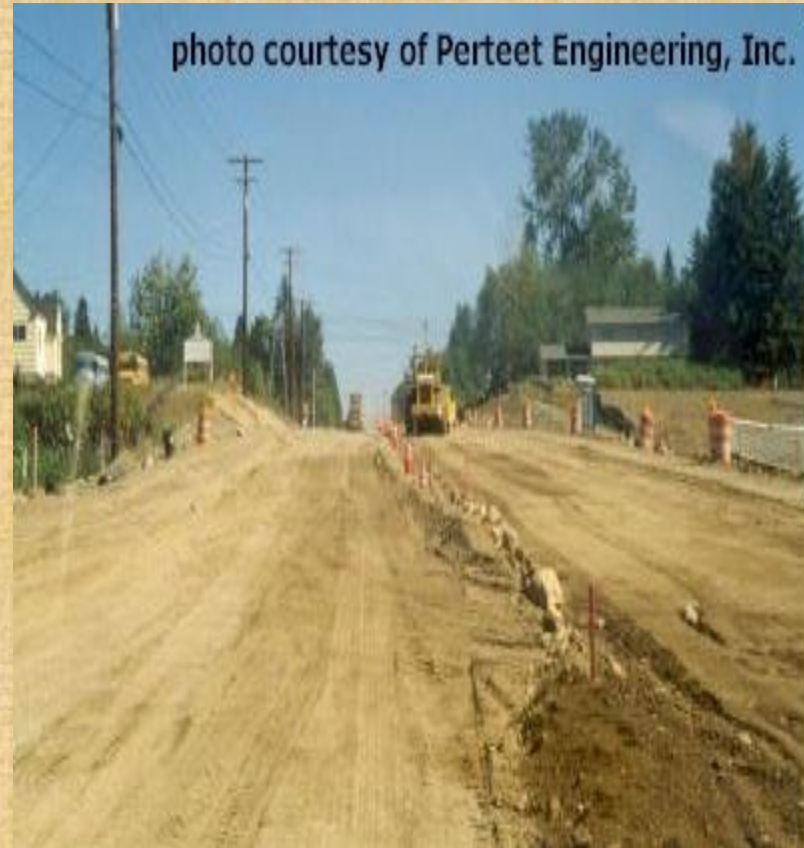

Cut and Fill Sections

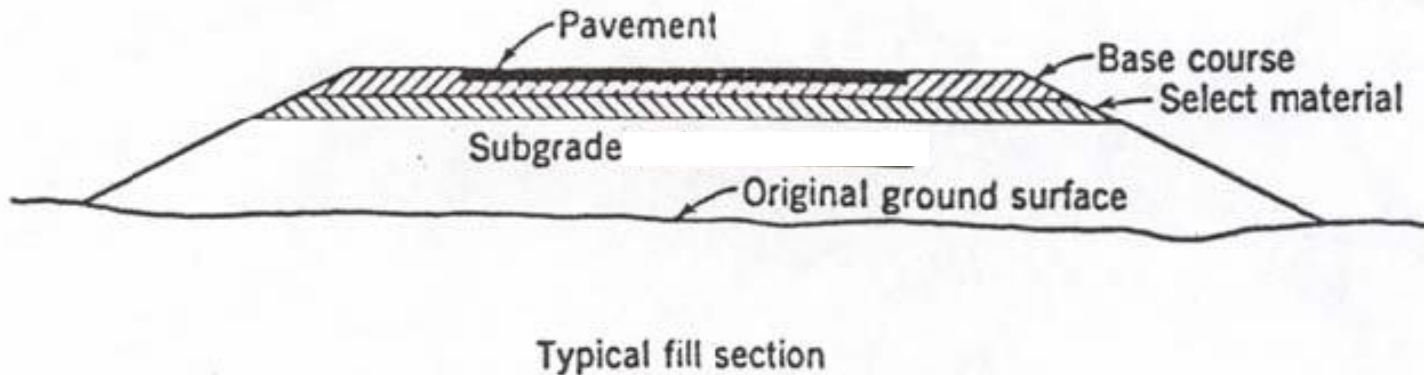
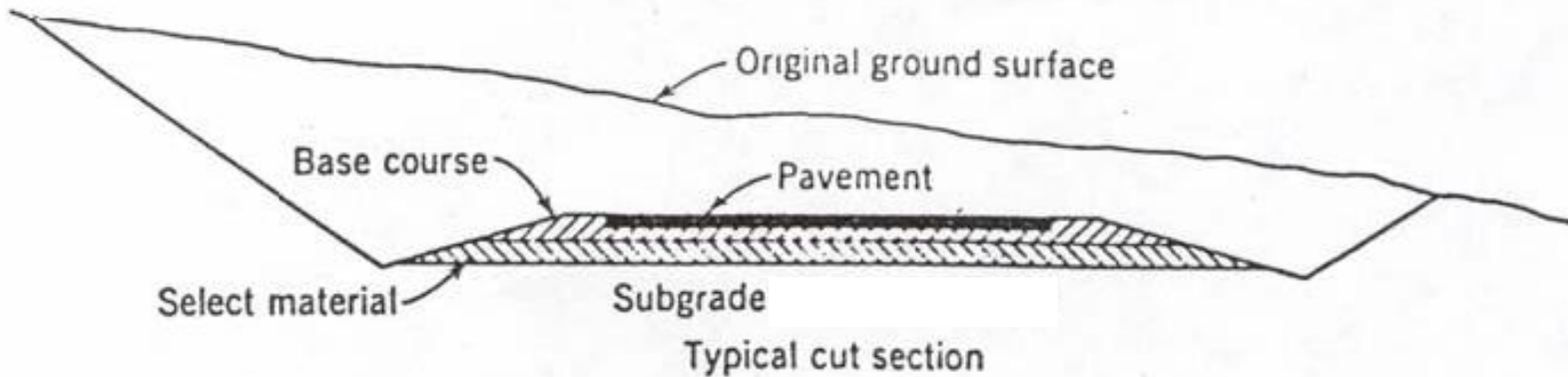

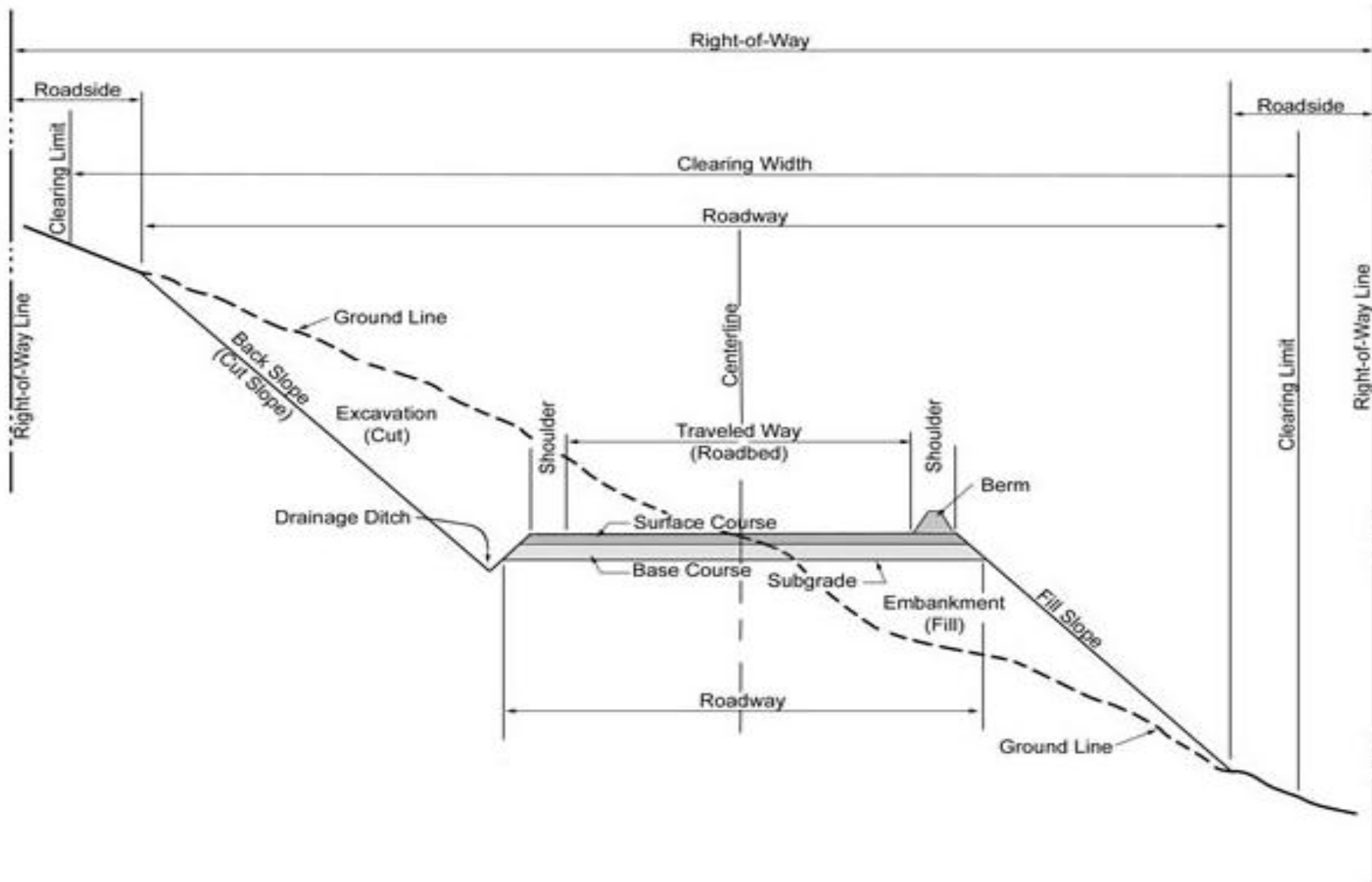

Typical Road Section (Cut & Fill)

Desirable Properties of Soil as Subgrade Material

- Stability
- Incompressibility
- Permanency of strength
- Minimum changes in volume and stability under adverse condition of weather and ground water
- Good drainage
- Ease of compaction

Subgrade Soil Strength

Assessed in terms of CBR of subgrade soil for most critical moisture conditions.

- Soil type
- Moisture Content
- Dry Density
- Internal Structure of the soil
- Type and Mode of Stress Application.

Pavement Responses Under Load

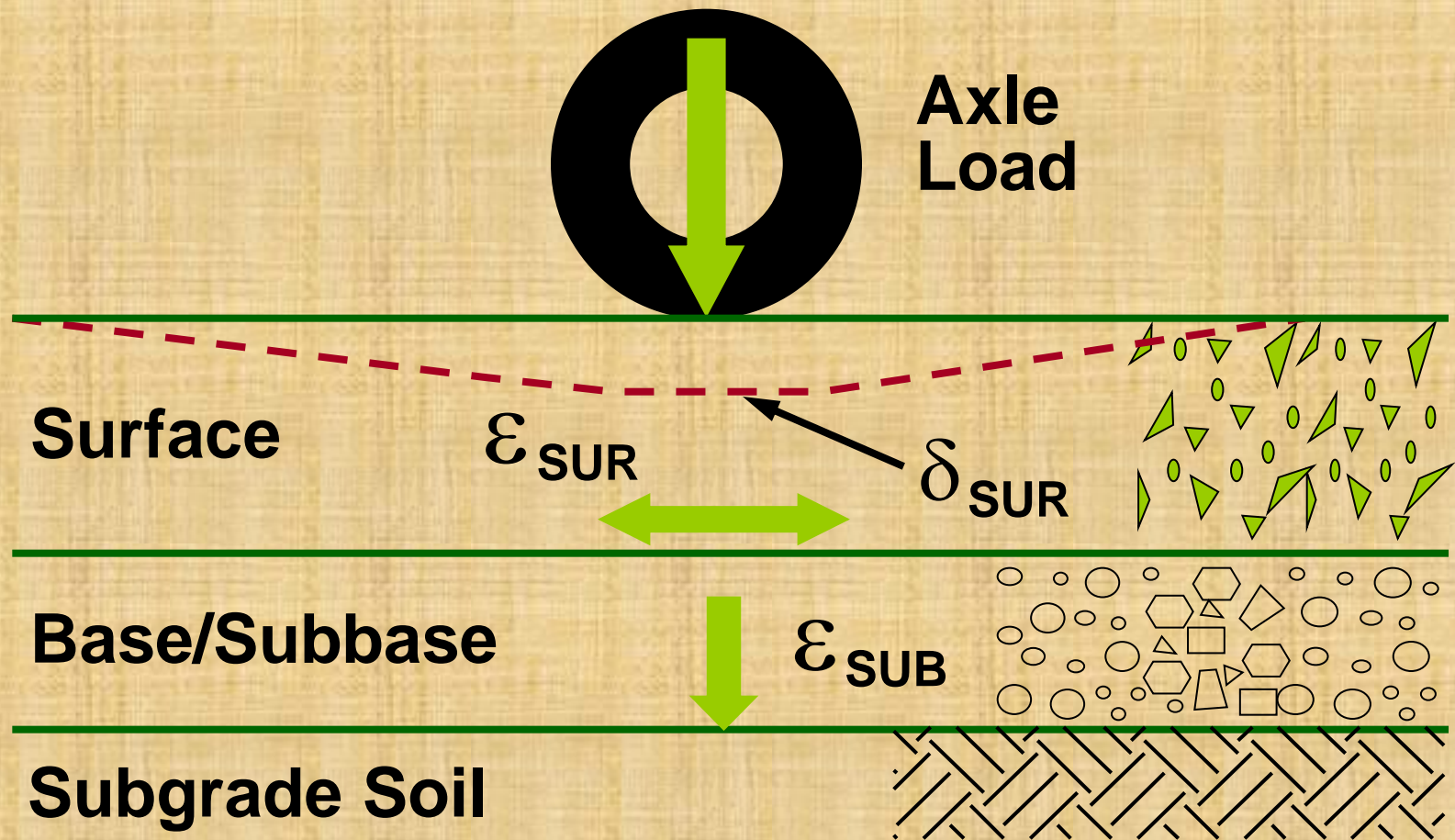

Subgrade Layer in Pavement Profile

Although a pavement's wearing course is most prominent, the success or failure of a pavement is more often dependent upon the underlying subgrade (the material upon which the pavement structure is built).

Subgrades are composed of a wide range of materials although some are much better than others.

photo courtesy of Pertect Engineering, Inc.



A subgrade's performance generally depends on three of its basic characteristics (all of which are interrelated):

1. **Load bearing capacity.** The subgrade **must be able to support loads transmitted** from the pavement structure. This load bearing capacity is often **affected by degree of compaction, moisture content, and soil type**. A subgrade that can support a high amount of loading without excessive deformation is considered good.
 2. **Moisture content.** Moisture tends to affect a number of subgrade properties including load bearing capacity, shrinkage and swelling. Moisture content can be **influenced by a number of things such as drainage, groundwater table elevation, infiltration, or pavement porosity** (which can be assisted by cracks in the pavement). Generally, excessively wet subgrades will deform excessively under load.
 3. **Shrinkage and/or swelling.** Some soils shrink or swell depending upon their moisture content. Additionally, soils with excessive fines content may be susceptible to frost heave. Shrinkage, swelling and frost heave will tend to deform and crack any pavement type constructed over them.
-

Poor Subgrade

Poor subgrade should be avoided if possible, but when it is necessary to build over weak soils there are several methods available to improve subgrade performance:

1. ***Removal and replacement (over-excavation)***. Poor subgrade soil can simply be removed and replaced with high quality fill. Although this is simple in concept, it can be expensive. Table shows typical over-excavation depths recommended by the **Colorado Asphalt Pavement Association (CAPA)**.

Subgrade Plasticity Index	Depth of Over-Excavation Below Normal Subgrade Elevation
10 - 20	0.7 meters (2 ft.)
20 - 30	1.0 meter (3 ft.)
30 - 40	1.3 meters (4 ft.)
40 - 50	1.7 meters (5 ft.)
More than 50	2.0 meters (6 ft.)

2. ***Stabilization with a cementitious or asphaltic binder.*** The addition of an appropriate binder (such as lime, portland cement or emulsified asphalt) can increase subgrade stiffness and/or reduce swelling tendencies.

Stabilization Material	Conditions Under which it is Recommended
Lime	Subgrades where expansion potential combined with a lack of stability is a problem.
Portland Cement	Subgrades which exhibit a plasticity index of 10 or less.
<u>Asphalt Emulsion</u>	Subgrades are sandy and do not have an excessive amount of material finer than the 0.075 mm (#200) sieve.

-
3. ***Additional base layers.*** Marginally poor subgrade soils may be compensated for by using additional base layers. These layers (usually of crushed stone – either stabilized or unstabilized) **serve to spread pavement loads over a larger subgrade area.** This option is rather perilous; when designing pavements for poor subgrades the temptation may be to just design a thicker section with more base material because the thicker section will satisfy most design equations. However, these equations are at least in part empirical and were usually not intended to be used in extreme cases. In short, a thick pavement structure over a poor subgrade **will not necessarily make a good pavement.**
-

Different Phases of Pavement Construction

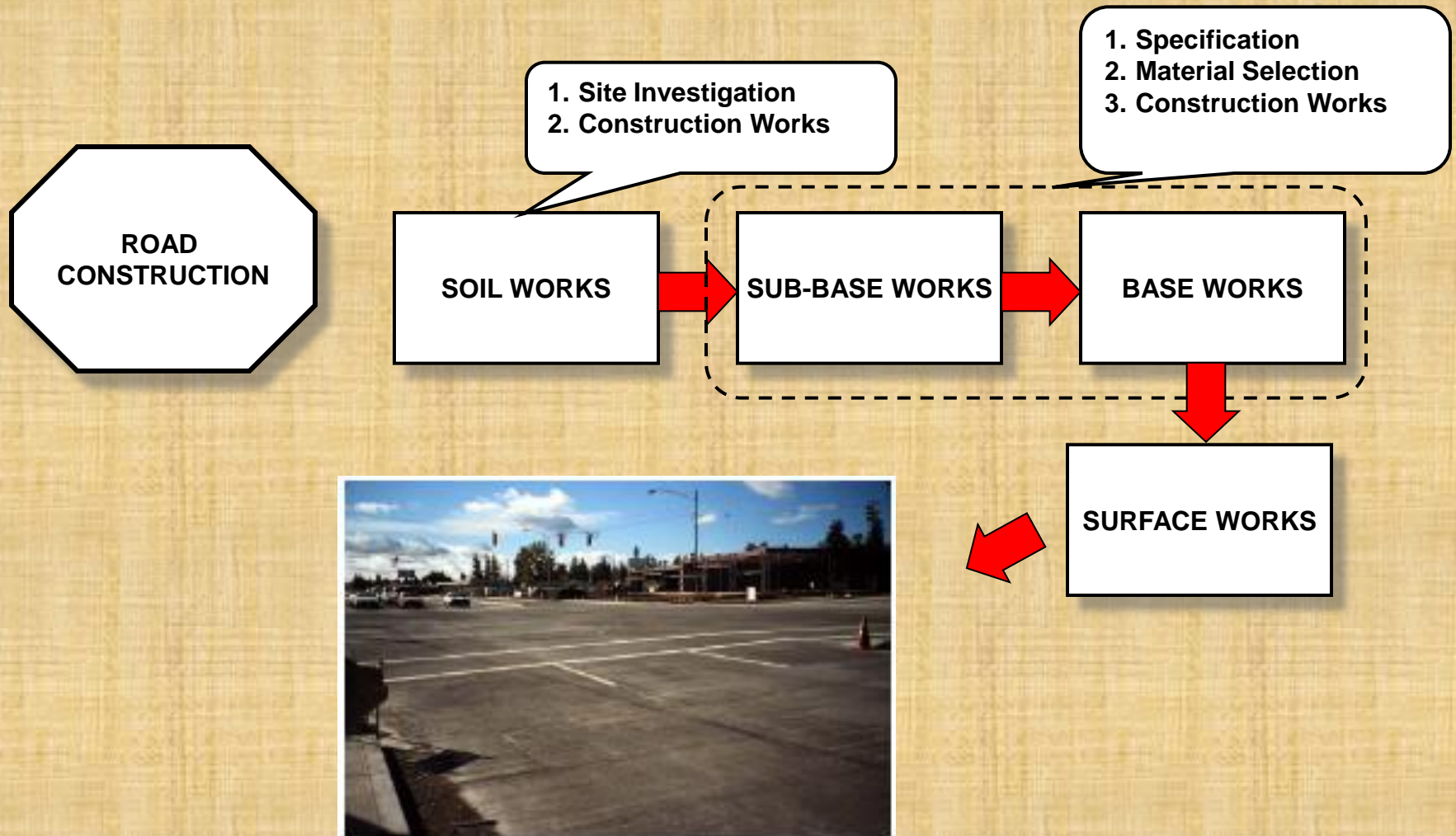

ROAD CONSTRUCTION

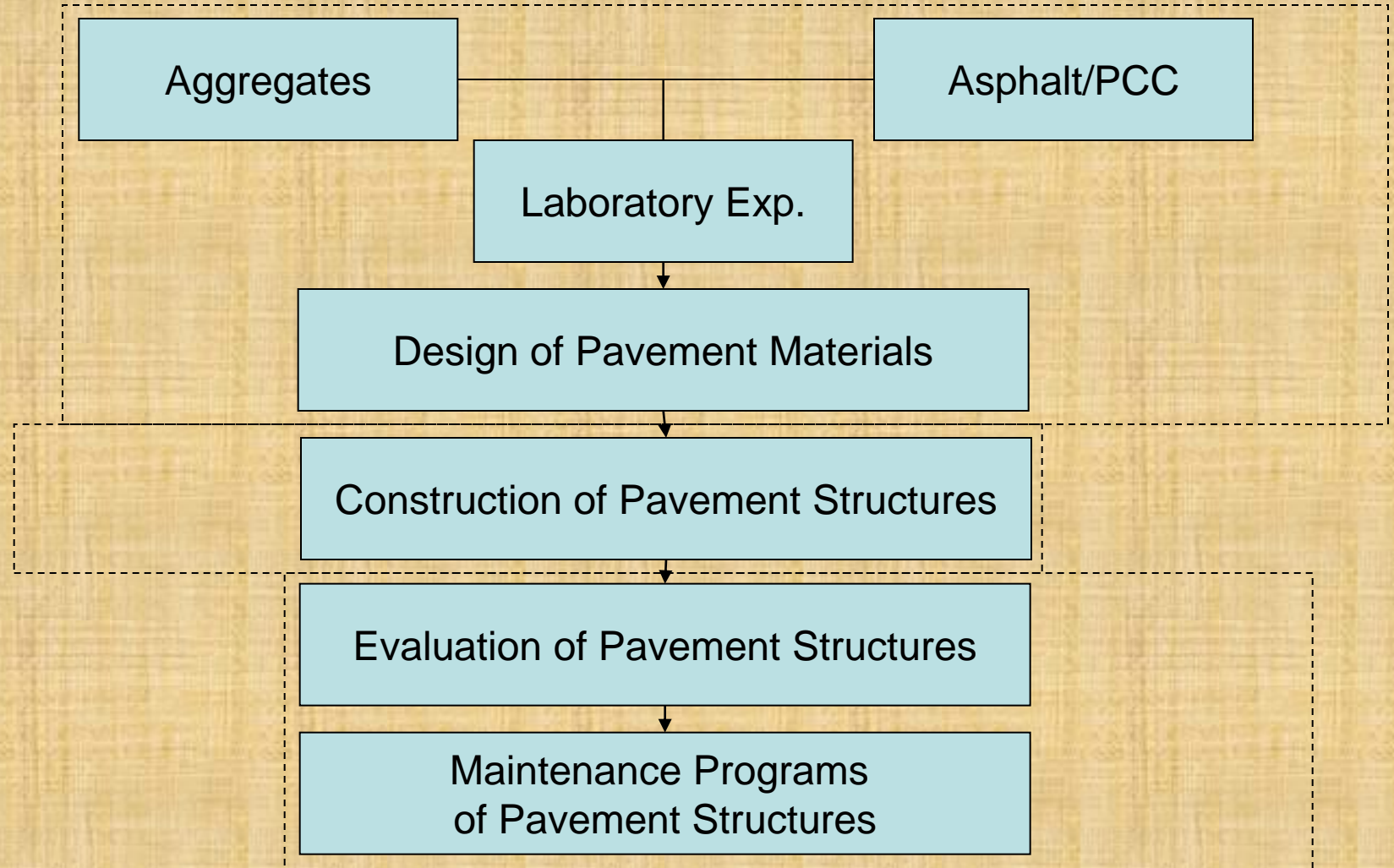

Three reasons of pavement failures:

- 1. Deformation* or rutting at high temperatures as asphalt softens
- 2. Fatigue* resulting in cracks due to high loads or aging
- 3. Low-temperature cracks*, as asphalt becomes brittle and shrinks in cold weather

Asphalt cement is held together by *aggregate interlock* or *internal friction*.

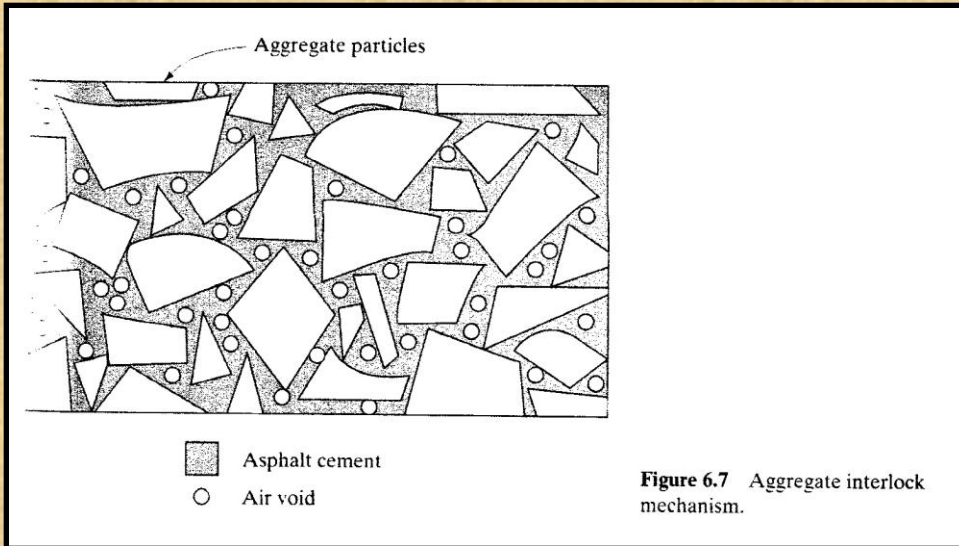

Air pockets account for 2-6% of the volume.

Aggregates constitute 70-75% by volume, or 90-95% by weight.

Excessive amounts of *binding material* tend to lubricate the particles and lower the stability of the pavement

Gravel has very little internal friction and interlocking, while crushed stone has high interlocking friction.

Particles should always be at the surface, to provide traction when the surface is wet.

Too much asphalt results in segregation of the asphalt and aggregate, called *bleeding* or *flushing*.

Aggregate Grading

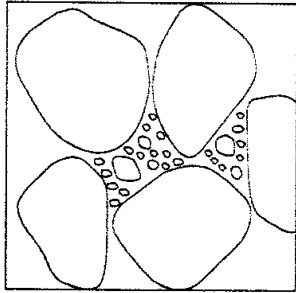

(a)

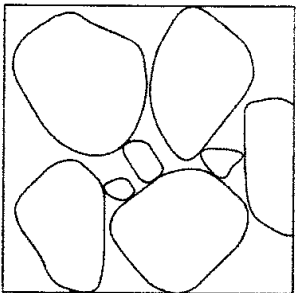

(b)

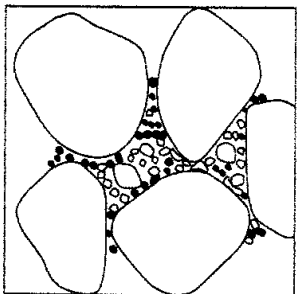

(c)

Open graded aggregate contains little or no fine aggregate. It has relatively large void space, and is good for roads requiring high permeability.

Intermediate-graded aggregate contains more sand than coarse aggregate. **Dense-graded** aggregate has high fill fraction, and slow curing rate.

Both **Coarse** and **Intermediate-graded** require a seal coat to make them impermeable to water, while **Dense-graded** aggregate does not require a seal coat.

According to ASTM, **Coarse aggregate** is graded aggregate made up of particles that are retained on a No. 4 Sieve. **Fine aggregate** almost entirely passes through a No. 4 sieve.

Figure 6.8 Types of gradation:
(a) dense-graded; (b) open-graded;
(c) too much fines.

There are two types of asphalt concretes:

Hot mixed, hot-laid mixtures (**HMA**) and

Cold-mixed, cold laid bituminous mixtures

Hot-mixed asphalt cement is aggregate mixed with asphalt cement, tar or emulsified asphalt. It must be heated to ~**300°F** prior to mixing.

Hot-mixed asphalt is:

- Durable
- Resistant to rutting
- Can sustain high loads and wider temperatures

Cold-mixed asphalt is:

- Made for lighter use
- Cheaper to apply
- Good for road repairs, resurfacing

Cold-mixed asphalt is aggregate mixed with **emulsified asphalt, cutback asphalt, or tar**, and applied at **ambient temperature**.

Asphalt pavement is flexible, requires less preparation than concrete pavement, and it can be repaired quickly.

It also requires a higher amount of maintenance, periodic surface treatments, and becomes hard and brittle with age and under load.

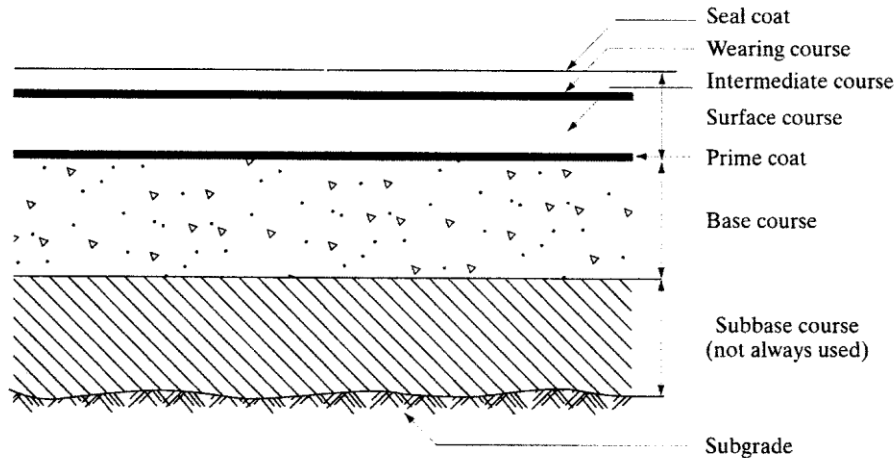

Figure 6.9 Typical flexible pavement cross-section.

Pavement is made up of four elements:

- Subgrade
- Subbase course
- Base course
- Surface course

The **subgrade** acts as the foundation, and may be **stabilized**.

The **subbase** is made of aggregates, sometimes mixed with lime.

The **base course** supports the wearing surface, and may be made of asphalt or untreated aggregate, such as crushed stone, gravel, sand, or cement.

The **surface course** is the finished asphalt concrete, sometimes topped with a sealant.

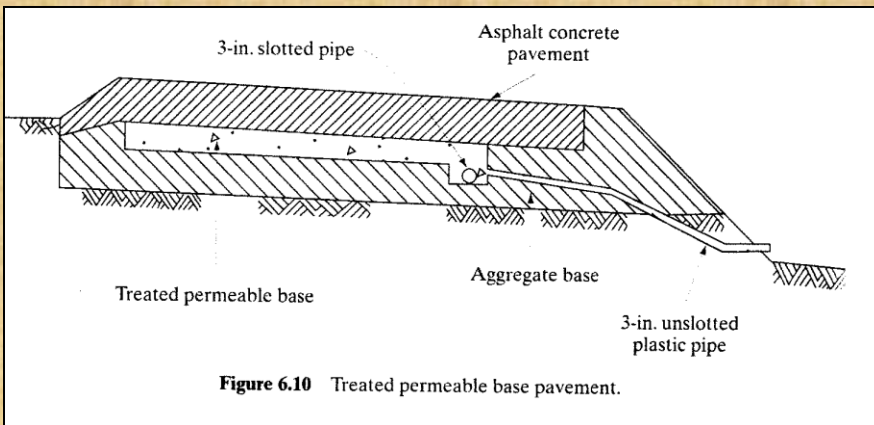

The **base course** may be designed to provide good drainage.

Various spray applications to pavement include:

Seal Coats – sprayed asphalt followed by application of stone/gravel cover. The largest aggregate is never more than twice the size of the smallest.

Fog seal is a light application of slow-setting emulsified asphalt, with or without aggregates

A **prime coat** is liquid asphalt applied to an untreated foundation layer or subgrade of stabilized soil, gravel, or water-bound macadam.

A **tack coat** is a thin coat of bituminous material applied to an existing surface to provide bond between the new construction and the existing surface

A **slurry seal** is a mixture of slow-setting emulsified asphalt, fine aggregate, mineral filler and water applied to the pavement without heat

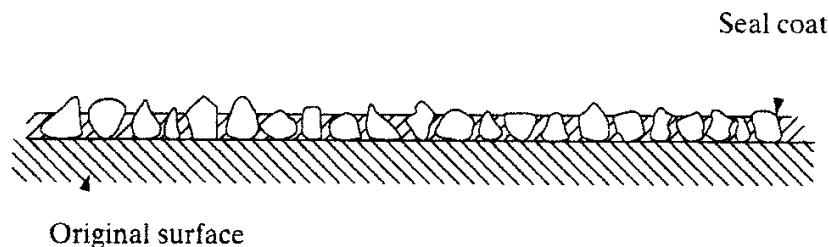

Figure 6.11 Seal coat with crushed stone/gravel cover.